

PLAN

AS-BUILT REPAIR QUANTITY TABLE				
TOP OF DECK REPAIRS				
	ESTIMATE		ACTUAL	
SCARIFYING BRIDGE DECK	158 SY			
HYDRO-DEMOLITION OF BRIDGE DECK	158 SY			
CLASS II SURFACE PREPARATION	16.0 SY *			
CLASS III SURFACE PREPARATION	0.5 SY *			
BRIDGE JOINT DEMOLITION	0.0 SF			
EPOXY RESIN INJECTION	0.0 LF			
CONCRETE FOR DECK REPAIR	3.0 CF *			
UNDERSIDE OF DECK REPAIRS				
SHOTCRETE REPAIRS	ESTIMATE		ACTUAL	
	AREA SF	VOLUME CF	AREA SF	VOLUME CF
UNDERSIDE OF DECK	0.0	0.0		
OVERHANG DIAPHRAGMS	0.0	0.0		
UNDERSIDE OF OVERHANG	0.0	0.0		
INTERIOR DIAPHRAGMS	0.0	0.0		
CONCRETE CURB AND RAIL	0.0	0.0		
	ESTIMATE		ACTUAL	
UNDERSIDE EPOXY RESIN INJECTION	2.0 LF			

VALUES IN CHARTS REPRESENT ESTIMATED UNDERSIDE OF DECK REPAIR TOTALS AFTER REMOVAL OF UNSOUND CONCRETE, MINIMUM OF 1" BEHIND REBAR AND MINIMUM 2" CLEARANCE TO SAWCUT. SEE REPAIR DETAILS.

- APPROX. CLASS II AREA
- APPROX. CLASS III AREA
- UNDERSIDE REPAIR
- DIAPHRAGM REPAIR
- CURB AND RAIL REPAIR
- #1 TEST LOCATION
- ERI EPOXY RESIN INJECTION

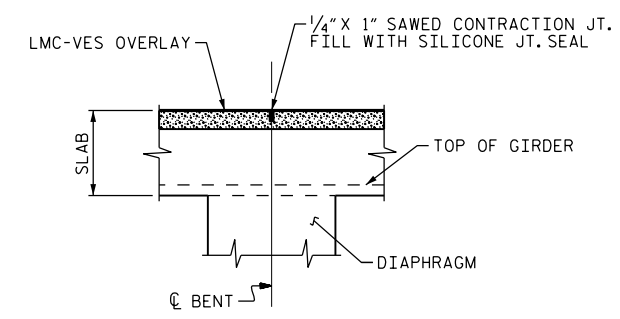

SECTION C-C

PROJECT NO. I-5892
BUNCOMBE COUNTY
 BRIDGE NO. 412
 SHEET 1 OF 3

TEST LOCATION	ASPHALT THICKNESS (INCH)	CONCRETE STRENGTH (PSI)
#1	5"	*
#2	5 3/4"	*
#3	5 1/2"	*

INFORMATION IN CHART TAKEN FROM DECK EVALUATION DATED 4/25/2016.
 * CONCRETE COMPRESSIVE STRENGTH COULD NOT BE TESTED DUE TO THE PRESENCE OF ASPHALT OVERLAY.

NOTES

- REPAIR LOCATIONS AND ESTIMATED QUANTITIES ARE GIVEN WITH THE BEST INFORMATION AVAILABLE. IF ADDITIONAL REPAIRS NOT SHOWN ON THE DRAWINGS ARE DEEMED NECESSARY BY THE ENGINEER, THE ENGINEER WILL NOTE ON THE DRAWINGS THE APPROXIMATE LOCATIONS AND DESCRIPTION OF THE REPAIRS AND ADJUST THE ACTUAL QUANTITIES ENTERED INTO THE AS-BUILT REPAIR QUANTITY TABLE.
- CONCRETE COVER FOR TOP BARS IN THE DECK SLAB IS 1/2" PER THE EXISTING BRIDGE PLANS.
- PRIOR TO PLACEMENT OF THE LMC-VES OVERLAY ACROSS THE CONTINUOUS DECK SPANS, THE CONTRACTOR SHALL SUBMIT A POUR SEQUENCE FOR APPROVAL BY THE ENGINEER.
- FOR UNDERSIDE OF DECK AND DIAPHRAGM REPAIRS, SEE "OVERHANG, DIAPHRAGM AND BRIDGE RAIL REPAIR DETAILS" SHEET.
- * CLASS II SURFACE PREPARATION, CLASS III SURFACE PREPARATION AND CONCRETE FOR DECK REPAIR ARE NOT ANTICIPATED. TOKEN PAY ITEMS ARE INDICATED FOR PRICING PURPOSES IN CASE UNANTICIPATED CLASS II OR CLASS III AREAS ARE ENCOUNTERED.

DocuSigned by:
John A. Yannaccone
 7BC90CCE898E

 1/21/2017

STATE OF NORTH CAROLINA
 DEPARTMENT OF TRANSPORTATION
 RALEIGH
 PLAN OF SPAN
 SPAN A

REVISIONS						SHEET NO.
NO.	BY:	DATE:	NO.	BY:	DATE:	S-5
1			3			TOTAL SHEETS
2			4			68

DRAWN BY : R.L. PUTEK DATE : 05/16
 CHECKED BY : S. WANCE DATE : 10/16

DOCUMENT NOT CONSIDERED FINAL UNLESS ALL SIGNATURES COMPLETED