

EXISTING JOINT

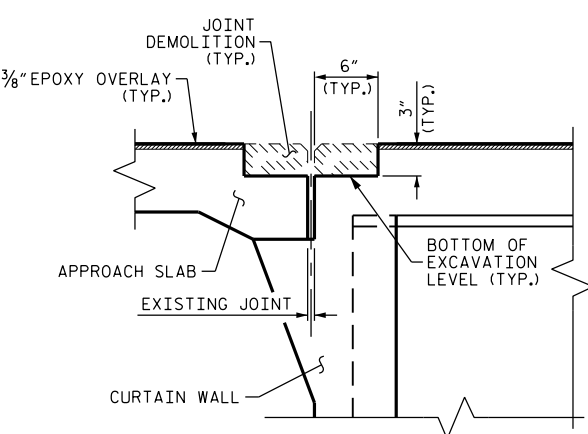

MINIMUM EXISTING JOINT DEMOLITION

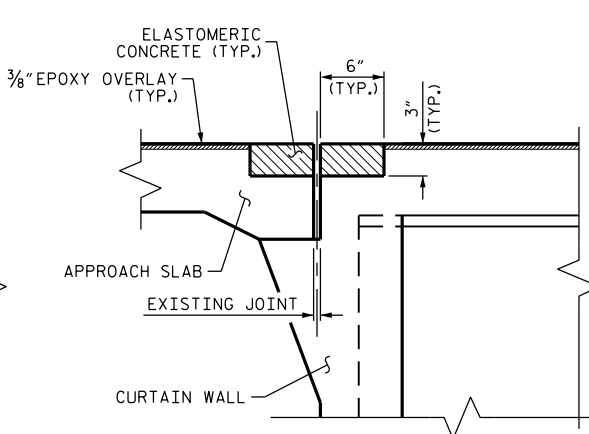

PROPOSED PRE-SAWED JOINT

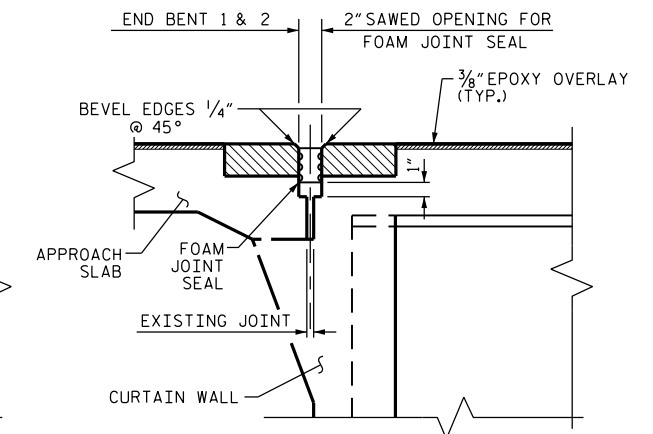

PROPOSED FOAM JOINT SEAL

SECTION A-A

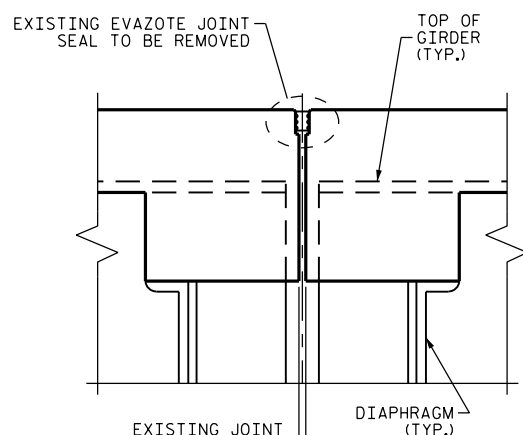

EXISTING JOINT

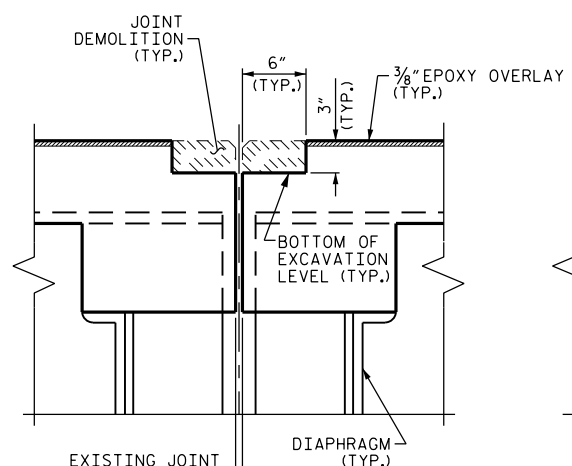

MINIMUM EXISTING JOINT DEMOLITION

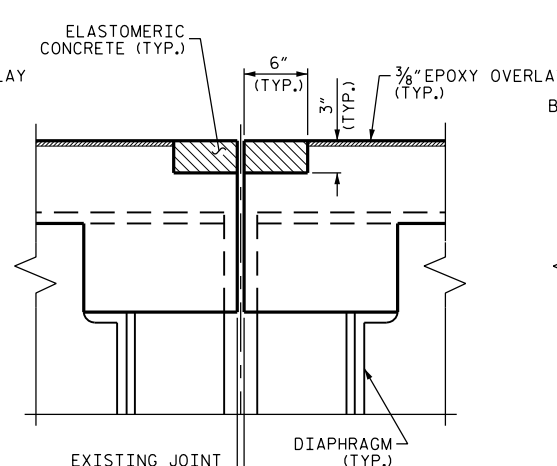

PROPOSED PRE-SAWED JOINT

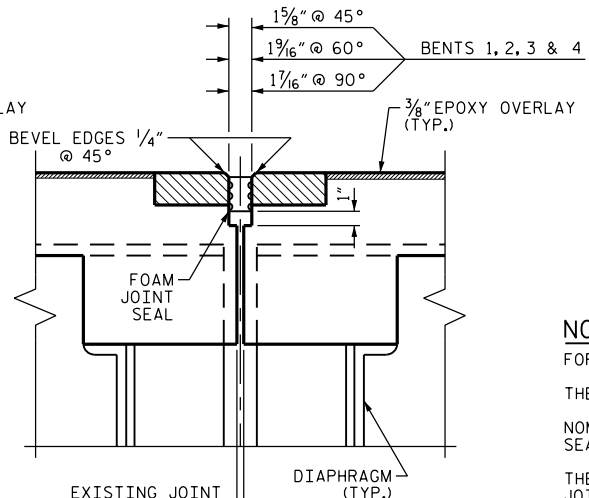

PROPOSED FOAM JOINT SEAL

SECTION B-B

ELASTOMERIC CONCRETE		
END BENT 1	16.8	(CU. FT.)
BENT 1	16.8	(CU. FT.)
BENT 2	16.8	(CU. FT.)
BENT 3	16.8	(CU. FT.)
BENT 4	16.8	(CU. FT.)
END BENT 2	16.8	(CU. FT.)
* TOTAL	100.8	(CU. FT.)

* BASED ON THE MINIMUM BLOCKOUT SHOWN.

NOTES:
 FOR FOAM JOINT SEALS SEE SPECIAL PROVISIONS.
 THE INSTALLED FOAM JOINT SEAL SHALL BE WATER TIGHT.
 NOMINAL UNCOMPRESSED SEAL WIDTH OF FOAM JOINT SEAL SHALL BE 2 1/2" AT THE END BENTS AND 2" AT THE BENTS.
 THE CONTRACTOR WILL NOT BE PERMITTED TO FORM THE JOINTS IN LIEU OF SAWING THE JOINT.
 FOR ELASTOMERIC CONCRETE, SEE SPECIAL PROVISIONS.

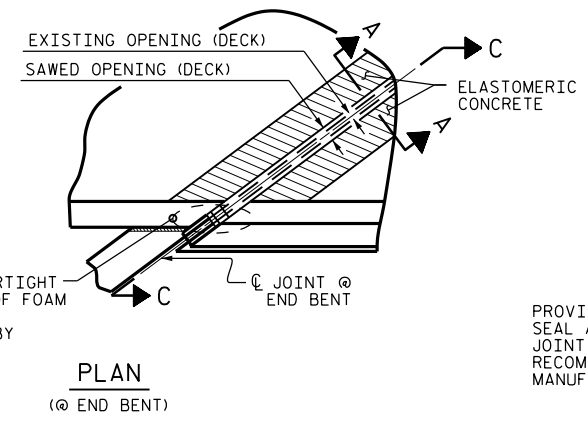

PLAN (@ END BENT)

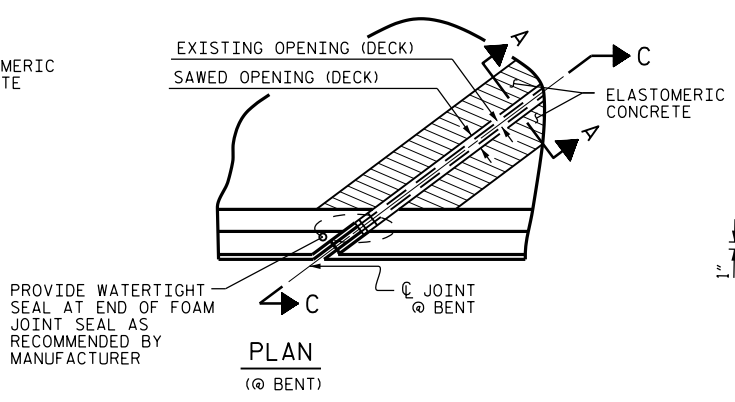

PLAN (@ BENT)

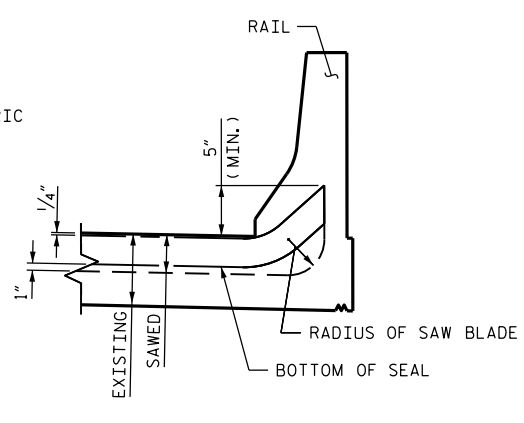

SECTION C-C

PROJECT NO. I-5809
McDOWELL COUNTY
 BRIDGE NO. 149

DocuSigned by:
John A. Yannaccone
 NORTH CAROLINA PROFESSIONAL SEAL 32492
 JOHN A. YANNACCONE
 ENGINEER

9/27/2016

STATE OF NORTH CAROLINA
 DEPARTMENT OF TRANSPORTATION
 RALEIGH

JOINT DETAILS

DRAWN BY : W.F. PARKER DATE : 05/16
 CHECKED BY : J.P. ADAMS DATE : 6/2016

REVISIONS						SHEET NO. S-33
NO.	BY:	DATE:	NO.	BY:	DATE:	
1			3			TOTAL SHEETS
2			4			68