

**SQUARE WASHER**  
1/4" THICK - GALVANIZED

**STEEL PLATE - 1/2"**  
GALVANIZED  
WELDED OR BOLTED TO POST

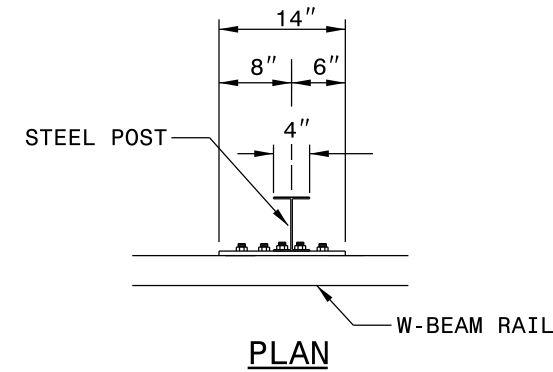

3 - 7/8" HOLES TO BE FIELD DRILLED IN RAIL AND ATTACHED TO STEEL PLATE WITH 7/8" HEX BOLTS 2" LONG WITH SQUARE WASHER

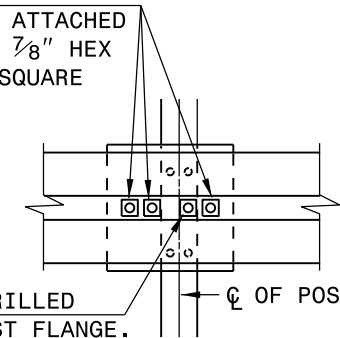

**FRONT VIEW**

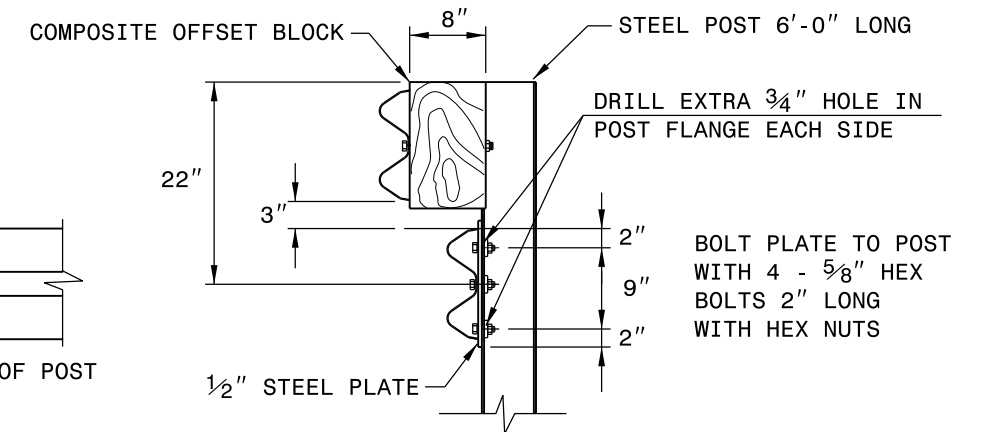

**ELEVATION**

**RUBRAIL ANCHOR DETAILS**

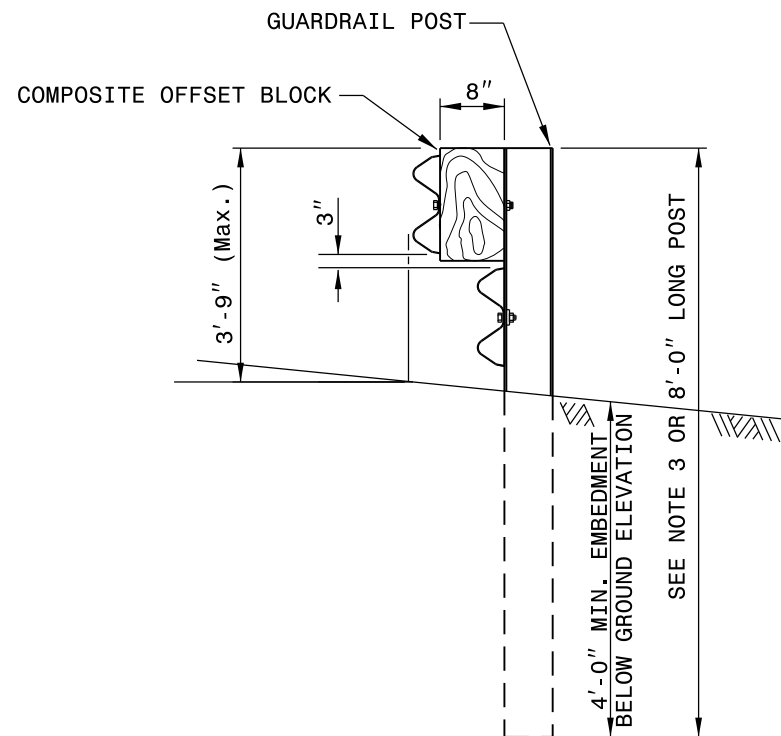

**ELEVATION**

**RAIL ATTACHMENT DETAIL**

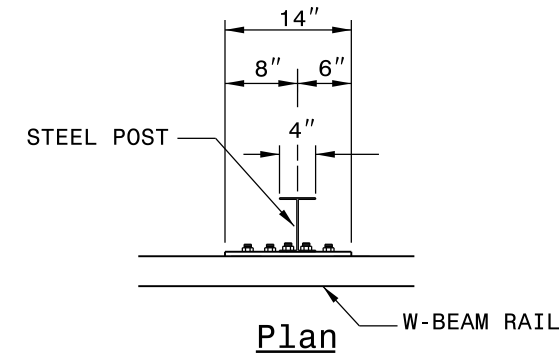

3 - 1" HOLES TO BE FIELD DRILLED IN RAIL AND ATTACHED TO STEEL PLATE WITH 7/8" HEX BOLTS 2" LONG WITH SQUARE WASHER

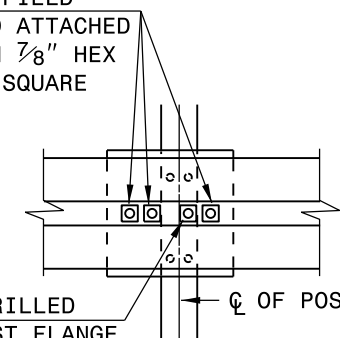

**FRONT VIEW**

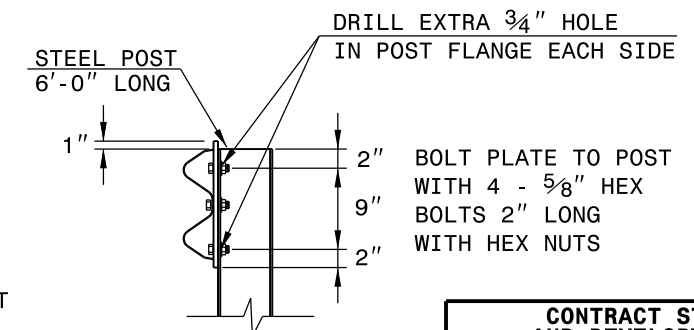

**ELEVATION**

**POST ANCHOR DETAILS**

SHEET 2 OF 2

<b>CONTRACT STANDARDS AND DEVELOPMENT UNIT</b>	
Office 919-707-6950	FAX 919-250-4119
<b>DETAIL OF GUARDRAIL BURIED IN CUT (BIC)</b>	
ORIGINAL BY: FHWA-G4 SYSTEM	DATE: 8-13-98
MODIFIED BY: E.E. WARD	DATE: 12-7-01
CHECKED BY:	DATE:
FILE SPEC.: ericward/misc.	guardrail/BIC.dwg

5/14/99