

RAILROAD PREEMPTION WIRING DETAIL

(wire as shown below)

ECONOLITE ASC/3-2070 RAILROAD PREEMPT PROGRAMMING DETAIL

(program controller as shown)

- From Main Menu select 4. PREEMPTOR/TSP
- From PREEMPTOR/TSP/SCP Submenu select 1. PREEMPT PLAN 1-10

Place cursor in [] next to Preempt Plan and press 1. Then press the right cursor arrow and toggle the controller to YES. Next cursor down. This will select Railroad Preempt #1.

```

PREEMPT PLAN [ 1 ]  ENABLE...YES
VEH/PED 1 2 3 4 5 6 7 8 9 0 1 2 3 4 5 6
OVERLAP A B C D E F G H I J K L M N O P
TRKCLR V . . . . .
TRKCLR O . . . . .
ENA TRL . . . . .
DWEL VEH . X . . . X . . . . .
DWEL PED . . . . .
DWEL OLP . . . . .
CYC VEH . X . . . X . . . . .
CYC PED . . . . .
CYC OLP . . . . .
EXIT PH . . . X . . . X . . . . .
EXIT CAL . X . . . X . . . . .
SP FUNC . . . . .
    
```

```

ENABLE... YESIPMT OVRIDE.XIINTERLOCK. NO
DET LOCK... XIDELAY.. 01INHIBIT... 0
OVERRIDE FL. IDURATION 0ICLR-GRN... NO
TERM OLP. NOIPC>YEL NOITERM PH NO
PED DARK.. NOITC RESRV YESIDWELL FL OFF
LINK PMT...0IX FLCOLR REDIXIT OPT. OFF
X TMG PLN...0IRE-SERV.. 0IFLT TYPE.HARD
FREE DUR PMTIR1 NOIR2 NOIR3 NOIR4 NO
--TIMING----WALKIPED CLIMN GRI YELI RED
ENTRANCE TM. 2551 2551 1125.5125.5
-----MIN GRIEXT GRIMX GRI YELI RED
TRACK CLEAR 101 01 0125.5125.5
-----MIN DLIPMTEXTIMX TMI YELI RED
DWL/CYC-EXIT 101 0.01 120125.5125.5
PMT ACTIVE OUT..ON PMT ACT DWELL...NO
OTHER - PRI PMT.OFF NON-PRI PMT....OFF
INH EXT TIME... 0.0 PED PR RETURN...OFF
PRIORITY RETURN.OFF QUEUE DELAY... OFF
COND DELAY.....OFF
PHASES 1 2 3 4 5 6 7 8
PR RTN% 0 0 0 0 0 0 0 0
PHASES 9 10 11 12 13 14 15 16
PR RTN% 0 0 0 0 0 0 0 0
    
```

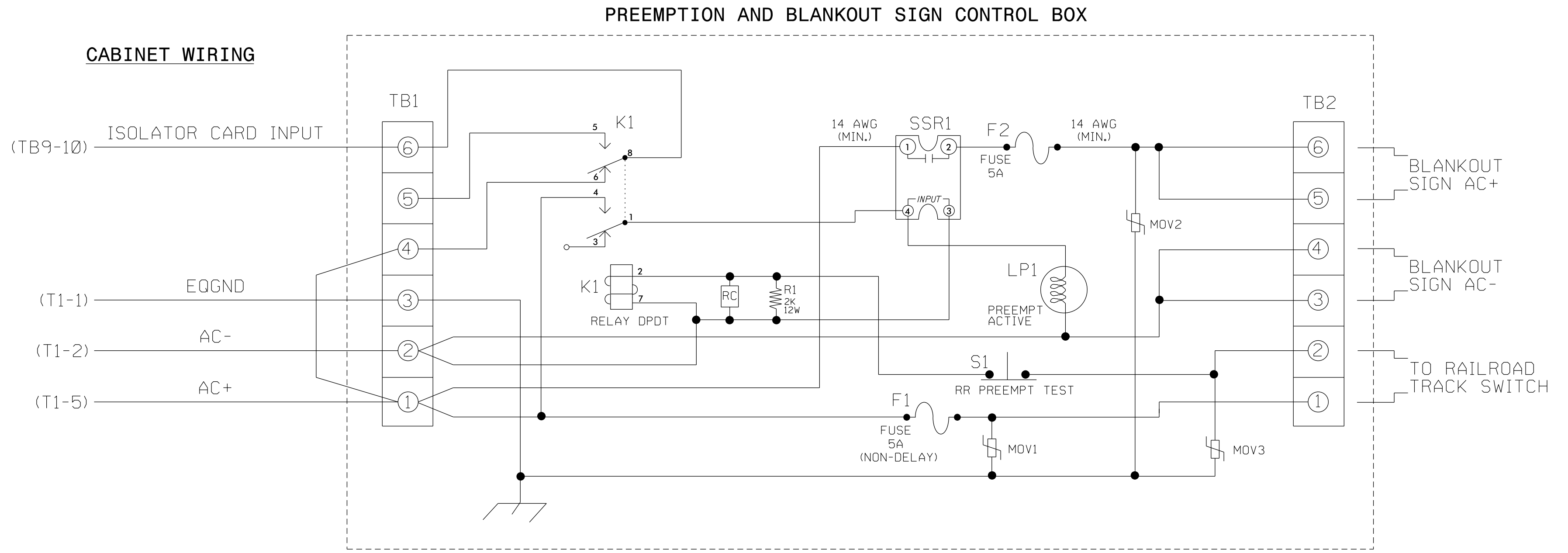

NOTES

- Relay K1 is shown in the energized (Preempt not active) normal operation state.
- Relay K1 is a DPDT with 120VAC coil with octal base.
- Relay SSR1 is a SPST (normally open) Solid State Relay with AC input and AC (25 amp) output.
- AC Isolator Card shall activate preemption upon removal of AC+ from the input (as shown above). To accomplish this set invert dip switch on AC Isolator Card.
- IMPORTANT!! A jumper must be added between input file terminals J14-E and J14-K if not already present. Also, terminal TB9-12 (on input panel) shall be connected to AC neutral (jumper may have to be added).

FRONT VIEW

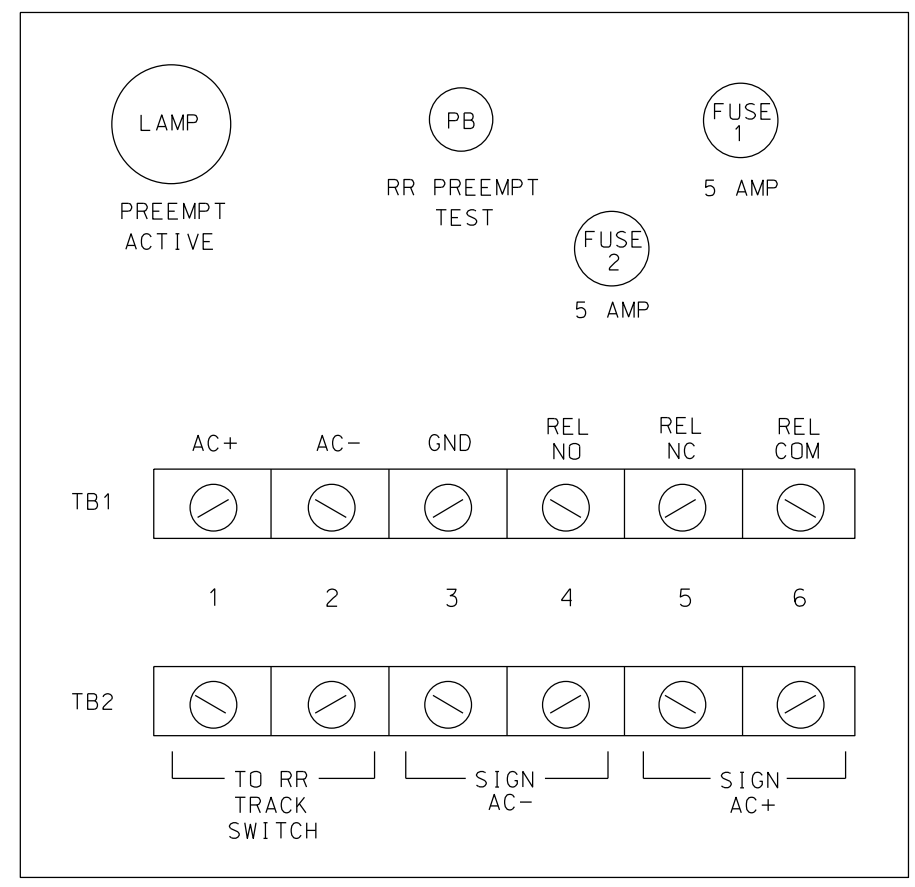

THIS ELECTRICAL DETAIL IS FOR THE SIGNAL DESIGN: C013
 DESIGNED: NOVEMBER 2016
 SEALED: 11/17/2016
 REVISED:

default \\NCF-DATA\Proj\360655_U-5742_Faj-Sig\Project\Signals\Design\100%\FINAL SEALED PLANS\Revised 1172016\Hillsboro.ct_Cumberland.dgn 11/17/2016 3:42:26 PM

Electrical Detail - Sheet 2 of 2

Prepared In the Offices of:
Hatch Mott MacDonald
 PO Box 700
 Fuquay-Varina, NC 27526
 www.hatchmott.com

| | | |
|---|---|--|
| DIV 06 CUMBERLAND COUNTY FAYETTEVILLE PLAN DATE: NOVEMBER 2016 REVIEWED BY: RWT PREPARED BY: BLR REVIEWED BY: | HILLSBORO ROAD AT CUMBERLAND STREET SEAL 032711 RUSSELL W. THOMPSON ENGINEER | SEAL NORTH CAROLINA PROFESSIONAL ENGINEER RUSSELL W. THOMPSON SEAL 032711 |
| | | |