

PHASING DIAGRAM

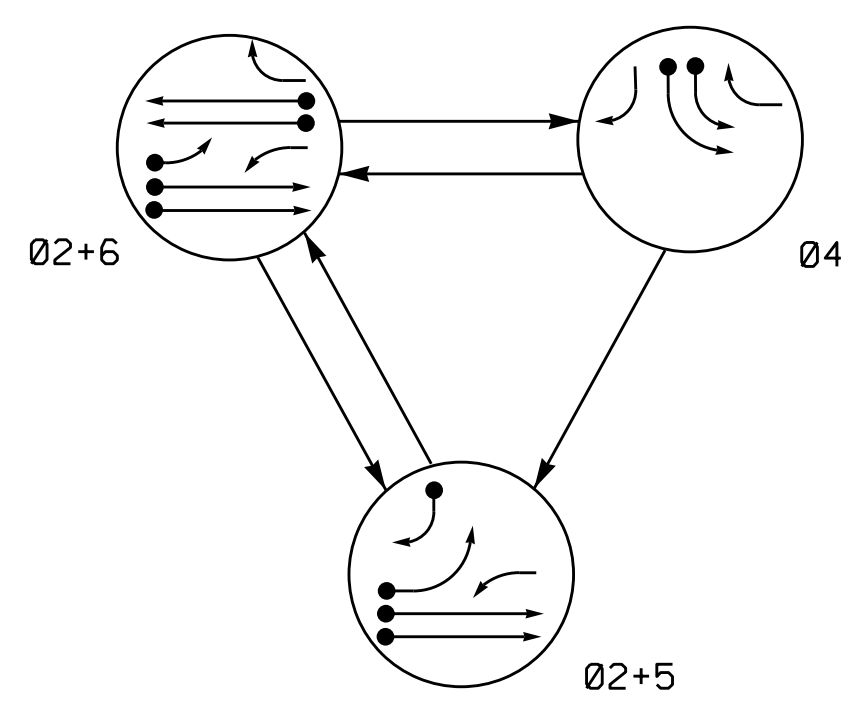

SIGNAL FACE	PHASE			
	Ø 2+5	Ø 2+6	Ø 4	FLASH
21,22	G	G	R	Y
41	R	R	G	R
42	R	R	G	R
51	F	F	R	Y
61	F	F	R	Y
62	R	G	R	Y
63	R	G	R	Y

SIGNAL FACE I.D.
All Heads L.E.D.

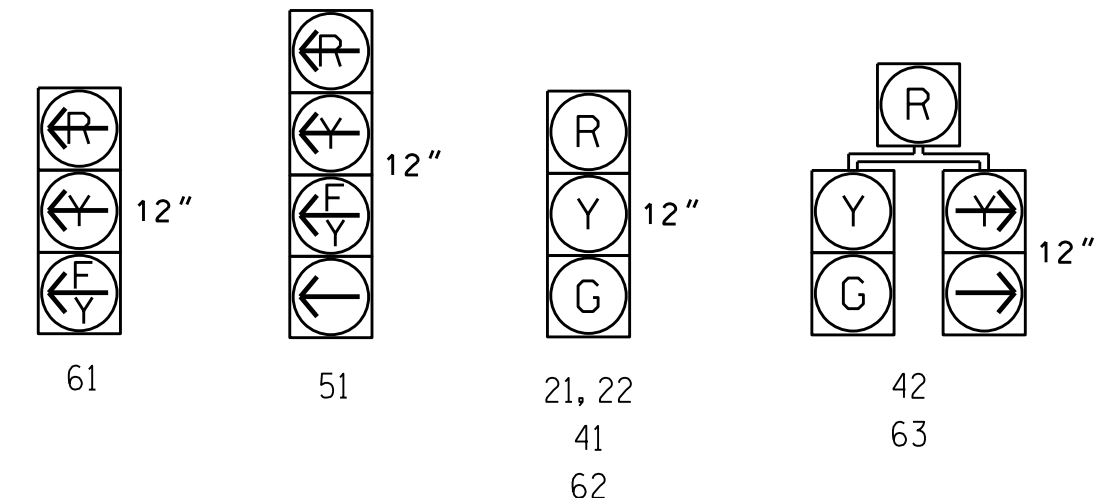

ASC/3 DETECTOR INSTALLATION CHART										
LOOP	SIZE (FT)	DISTANCE FROM STOPBAR (FT)	TURNS	NEW LOOP	PROGRAMMING					
					PHASE	CALLING	EXTEND TIME	DELAY TIME	TYPE	SYSTEM LOOP
2A	6X6	300	5	-	2	Yes	-	-	N	- X
2B	6X6	300	5	-	2	Yes	-	-	N	- X
4A	6X40	0	2-4-2	-	4	Yes	-	-	S	- X
4B	6X40	0	2-4-2	-	4	Yes	-	-	S	- X
5A	6X40	0	2-4-2	-	5	Yes	-	15	S	- X
5B	6X40	0	2-4-2	-	5	Yes	-	15	S	- X
6A	6X6	300	5	-	6	Yes	-	-	N	- X
6B	6X6	300	5	-	6	Yes	-	-	N	- X

3 Phase Fully Actuated Fayetteville Signal System

NOTES

- Refer to "Roadway Standard Drawings NCDOT" dated January 2012 and "Standard Specifications for Roads and Structures" dated January 2012.
- Do not program signal for late night flashing operation unless otherwise directed by the Engineer.
- Phase 5 may be lagged.
- Set all detector units to presence mode.
- Locate new cabinet so as not to obstruct sight distance of vehicles turning right on red. Pavement markings are existing.
- Maximum times shown in timing chart are for free-run operation only. Coordinated signal system timing values supercede these value.

PHASING DIAGRAM DETECTION LEGEND

- → DETECTED MOVEMENT
- → UNDETECTED MOVEMENT (OVERLAP)
- → UNSIGNALIZED MOVEMENT
- → PEDESTRIAN MOVEMENT

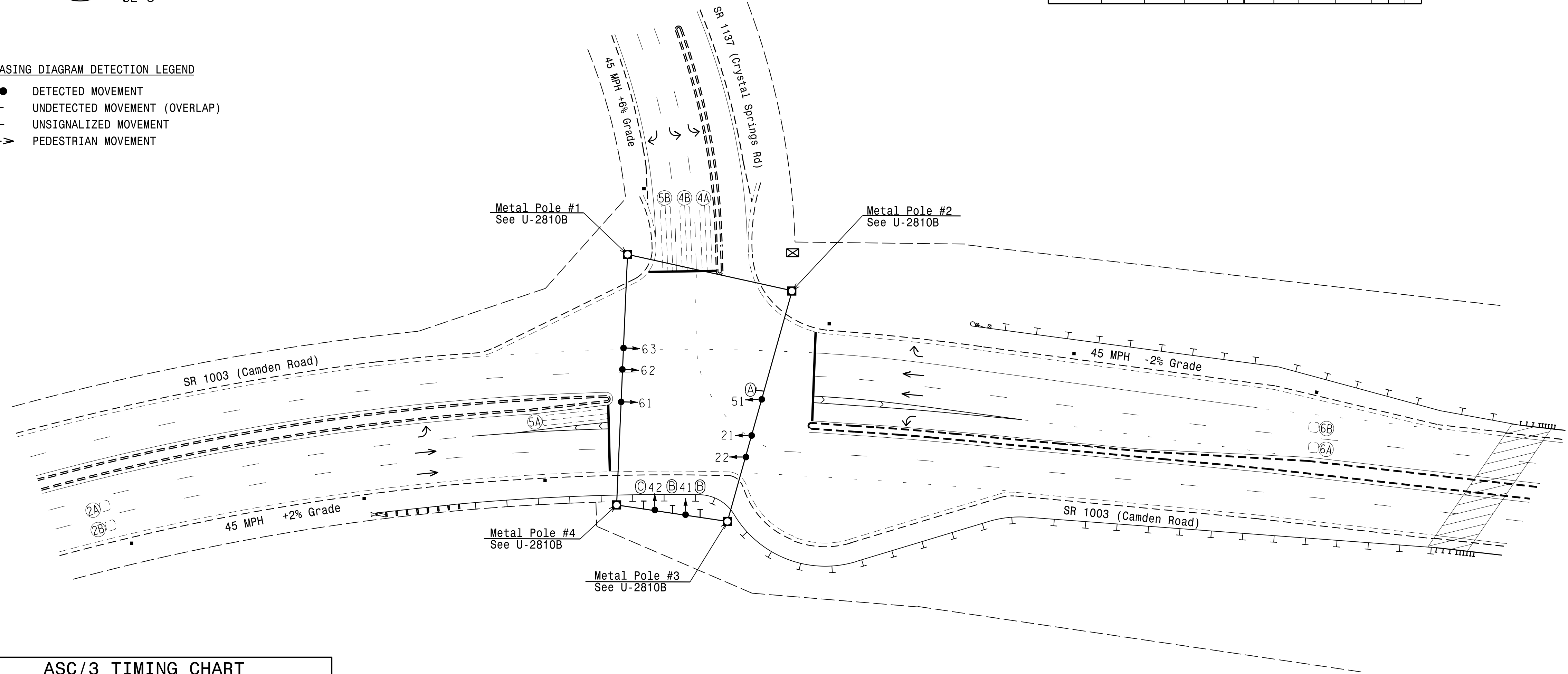

LEGEND

- | PROPOSED | EXISTING |
|--|--|
| ○ → Traffic Signal Head | ● → Traffic Signal Head |
| ○ → Modified Signal Head | N/A |
| □ → Sign | □ → Sign |
| □ → Pedestrian Signal Head With Push Button & Sign | □ → Pedestrian Signal Head With Push Button & Sign |
| □ → Signal Pole with Guy | □ → Signal Pole with Guy |
| □ → Signal Pole with Sidewalk Guy | □ → Signal Pole with Sidewalk Guy |
| □ → Metal Strain Pole | □ → Metal Strain Pole |
| □ → Inductive Loop Detector | □ → Inductive Loop Detector |
| □ → Controller & Cabinet | □ → Controller & Cabinet |
| □ → Junction Box | □ → Junction Box |
| --- → 2-in Underground Conduit | --- → 2-in Underground Conduit |
| N/A → Right of Way | --- → Right of Way |
| → → Directional Arrow | → → Directional Arrow |
| N/A → Guardrail | --- → Guardrail |
| (A) → "U-TURN YIELD TO RIGHT TURN" Sign (R10-16) | (A) → "U-TURN YIELD TO RIGHT TURN" Sign (R10-16) |
| (B) → Left Arrow "ONLY" Sign (R3-5L) | (B) → Left Arrow "ONLY" Sign (R3-5L) |
| (C) → Right Arrow "ONLY" Sign (R3-5R) | (C) → Right Arrow "ONLY" Sign (R3-5R) |

ASC/3 TIMING CHART

FEATURE	PHASE			
	2	4	5	6
Min Green *	12	7	7	12
Walk *	0	0	0	0
Ped Clear	0	0	0	0
Veh. Extension *	6.0	2.0	2.0	6.0
Max 1 *	90	25	15	90
Yellow	4.7	3.0	3.0	4.7
Red Clear	1.8	3.6	3.1	1.8
Actuations B4 Add *	0	-	-	0
Seconds / Actuation *	1.5	-	-	1.5
Max Initial *	34	-	-	34
Time Before Reduction *	15	-	-	15
Time To Reduce *	40	-	-	40
Minimum Gap	3.0	-	-	3.0
Locking Detector	X	-	-	X
Recall Position	VEH. RECALL	-	-	VEH. RECALL
Dual Entry	-	-	-	-
Simultaneous Gap	X	X	X	X

* These values may be field adjusted. Do not adjust Min Green and Extension times for phases 2 and 6 lower than what is shown. Min Green for all other phases should not be lower than 4 seconds.

Signal Upgrade

	<p>SR 1003 (Camden Rd) at SR 1137 (Crystal Springs Rd)</p>		<p>SEAL NORTH CAROLINA PROFESSIONAL ENGINEER JASON P. GALLOWAY SEAL 029904</p>
	<p>Division 6 Cumberland County Fayetteville</p>		
<p>750 N. Greenfield Pkwy, Garner, NC 27529</p>	<p>PLAN DATE: January 2016</p>	<p>REVIEWED BY: EM Minshew</p>	<p>DATE: 5/11/2016</p>
<p>SCALE: 1" = 40'</p>	<p>REVISIONS</p>	<p>INIT.</p>	<p>DATE</p>
<p>DOCUMENT NOT CONSIDERED FINAL UNLESS ALL SIGNATURES COMPLETED</p>			<p>SIG. INVENTORY NO. 06-1268</p>

09-MAY-2016 12:53 S:\MIS\5151\15-SIGNAL\Signal Design Section\Eastern Region\04\U-5742 Fayetteville ASC\3\06-1268\061268.s1g.dsn_2016mmd.dgn