

EDI MODEL 2018ECLip-NC CONFLICT MONITOR PROGRAMMING DETAIL

(remove jumpers and set switches as shown)

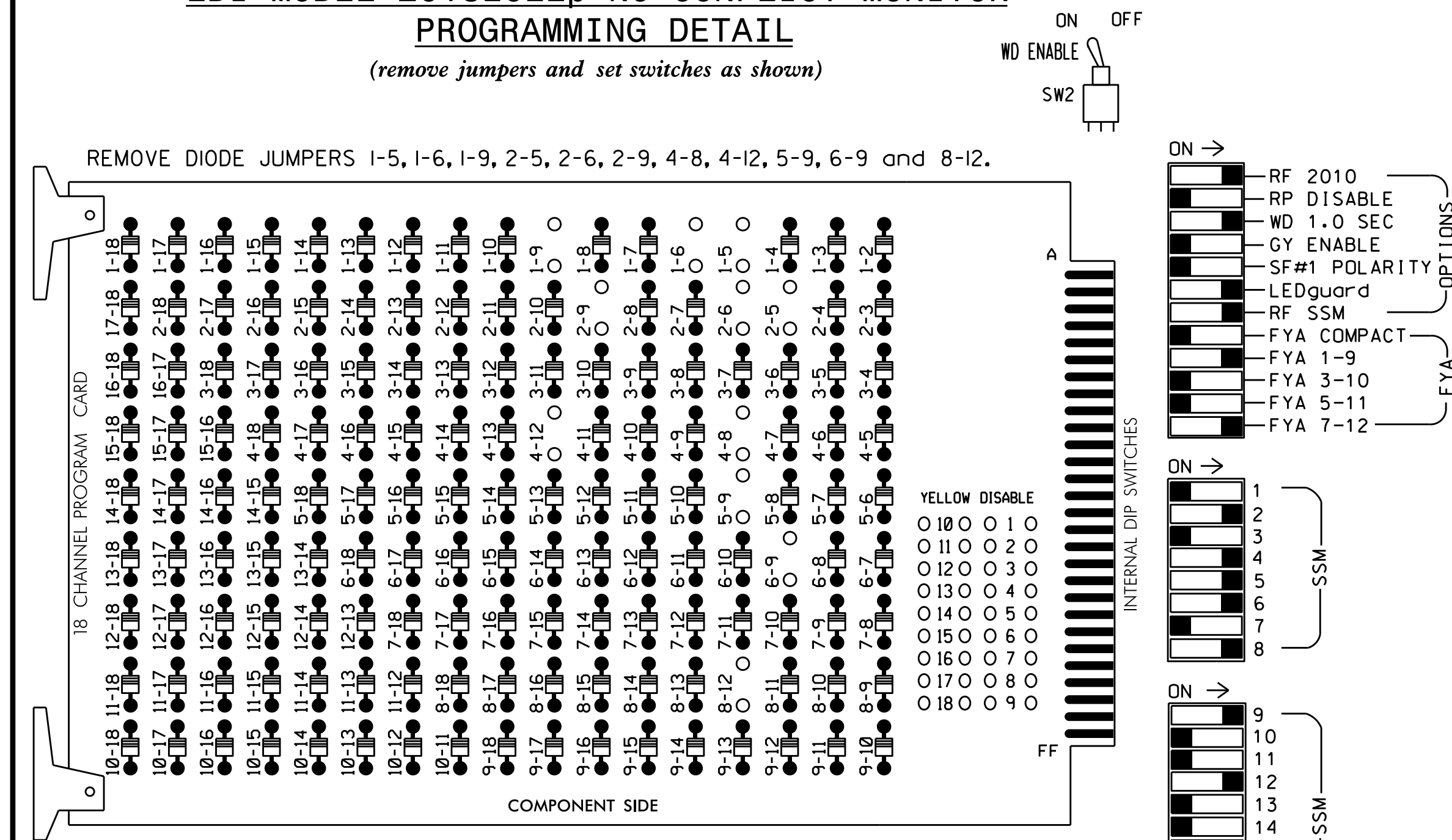

REMOVE DIODE JUMPERS 1-5, 1-6, 1-9, 2-5, 2-6, 2-9, 4-8, 4-12, 5-9, 6-9 and 8-12.

REMOVE JUMPERS AS SHOWN

NOTES:

- Card is provided with all diode jumpers in place. Removal of any jumper allows its channels to run concurrently.
- Ensure jumpers SEL2-SEL5 and SEL9 are present on the monitor board.
- Ensure that Red Enable is active at all times during normal operation.
- Integrate monitor with Ethernet network in cabinet.

NOTES

- To prevent "flash-conflict" problems, insert red flash program blocks for all unused vehicle load switches in the output file. The installer shall verify that signal heads flash in accordance with the Signal Plans.
- Program phases 4 and 8 for Dual Entry.
- Enable Simultaneous Gap-Out for all phases.
- Program phases 2 and 6 for volume density operation.
- Program controller to start up in phase 2 Green and 6 Green.
- The cabinet and controller are part of the Fayetteville Signal System.

EQUIPMENT INFORMATION

CONTROLLER.....2070E
 CABINET.....332 W/AUX
 SOFTWARE.....ECONOLITE ASC/3-2070
 CABINET MOUNT.....BASE
 OUTPUT FILE POSITIONS...18 WITH AUX. OUTPUT FILE
 LOAD SWITCHES USED.....S1,S2,S5,S7,S8,S11,AUX S1,
 AUX S5
 PHASES USED.....1,2,4,5,6,8
 OVERLAP "A".....*
 OVERLAP "B".....NOT USED
 OVERLAP "C".....NOT USED
 OVERLAP "D".....*
 * See overlap programming detail on sheet 2

SIGNAL HEAD HOOK-UP CHART

LOAD SWITCH NO.	S1	S2	S3	S4	S5	S6	S7	S8	S9	S10	S11	S12	AUX S1	AUX S2	AUX S3	AUX S4	AUX S5	AUX S6	
CMU CHANNEL NO.	1	2	13	3	4	14	5	6	15	7	8	16	9	10	17	11	12	18	
PHASE	1	2	2 PED	3	4	4 PED	5	6	6 PED	7	8	8 PED	OLA	OLB	SPARE	OLC	OLD	SPARE	
SIGNAL HEAD NO.	11*	21,22	NU	NU	42,43	NU	43	51,52	61,62	NU	NU	81,82	NU	11*	NU	NU	NU	41*	NU
RED		128			101				134			107							
YELLOW	*	129			102				135			108							
GREEN		130			103				136			109							
RED ARROW									131					A121					A101
YELLOW ARROW								132	132					A122					A102
FLASHING YELLOW ARROW														A123					A103
GREEN ARROW	127							133	133										

NU = Not Used

* Denotes install load resistor. See load resistor installation detail this sheet.

* See pictorial of head wiring in detail this sheet.

FYA SIGNAL WIRING DETAIL

(wire signal heads as shown)

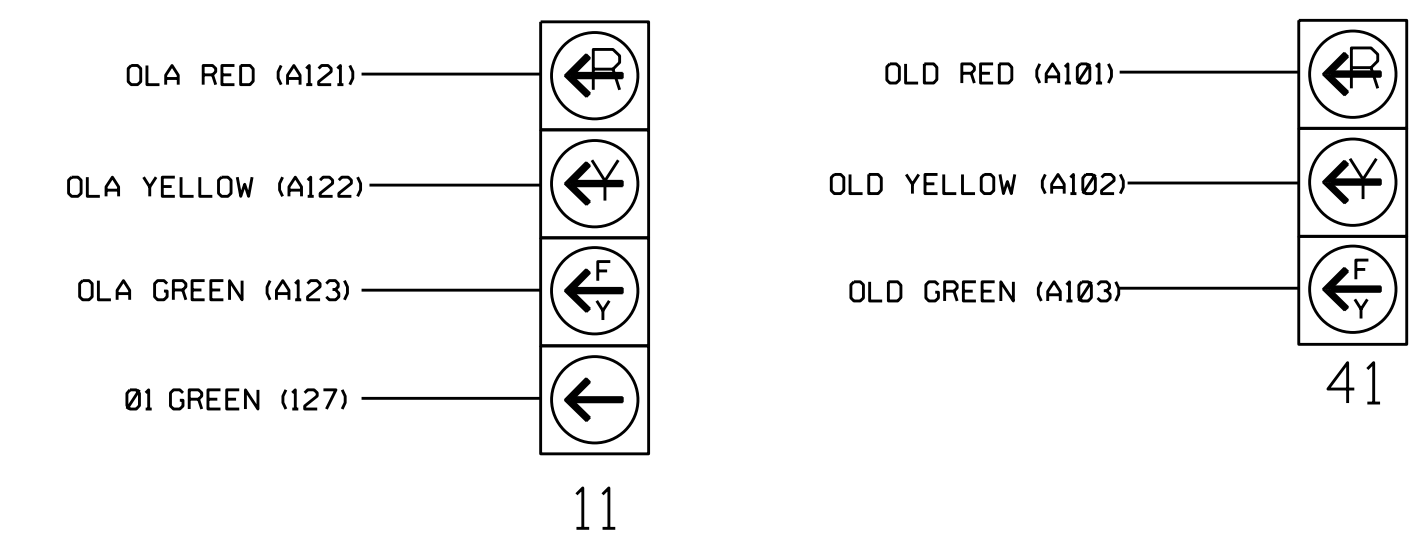

INPUT FILE POSITION LAYOUT

(front view)

FILE "I"	1	2	3	4	5	6	7	8	9	10	11	12	13	14
U	Ø 1	Ø 2	Ø 3	Ø 4	Ø 5	Ø 6	Ø 7	Ø 8	Ø 9	Ø 10	Ø 11	Ø 12	Ø 13	Ø 14
L	1A	2A	3A	4A	5A	6A	7A	8A	9A	10A	11A	12A	13A	14A
U	NOT USED	Ø 2	Ø 3	Ø 4	Ø 5	Ø 6	Ø 7	Ø 8	Ø 9	Ø 10	Ø 11	Ø 12	Ø 13	Ø 14
L	2B	3B	4B	5B	6B	7B	8B	9B	10B	11B	12B	13B	14B	15B

EX.: 1A, 2A, ETC. = LOOP NO.'S

FS = FLASH SENSE
 ST = STOP TIME

⊗ Wired Input - Do not populate slot with detector card

INPUT FILE CONNECTION & PROGRAMMING CHART

LOOP NO.	LOOP TERMINAL	INPUT FILE POS.	PIN NO.	DETECTOR NO.	NEMA PHASE	CALL	EXTEND TIME	DELAY TIME	DETECTOR TYPE
1A ¹	TB2-1,2	I1U	56	1	1	YES		15	S
		J4U	48	26	6	YES		3	G
2A	TB2-5,6	I2U	39	2	2	YES			N
2B	TB2-7,8	I2L	43	12	2	YES			N
4A	TB4-9,10	I6U	41	4	4	YES			S
4B	TB4-11,12	I6L	45	14	4	YES			S
5A	TB3-1,2	J1U	55	5	5	YES			S
5B	TB3-5,6	J2U	40	6	5	YES			S
5C	TB3-7,8	J2L	44	16	5	YES		15	S
6A	TB3-9,10	J3U	64	36	6	YES			N
6B	TB3-11,12	J3L	77	46	6	YES			N
8A	TB5-9,10	J6U	42	8	8	YES		10	S

¹Add jumper from I1-W to J4-W, on rear of input file.

INPUT FILE POSITION LEGEND: J2L

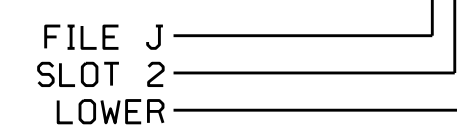

LOAD RESISTOR INSTALLATION DETAIL

(install resistors as shown)

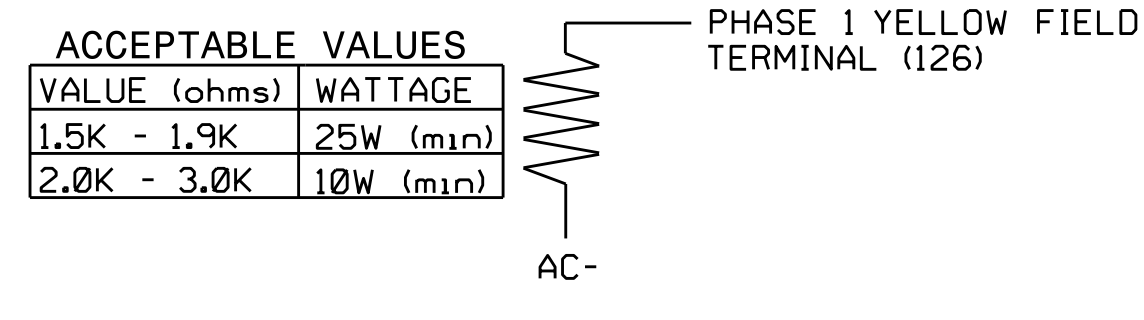

Electrical Detail Sheet 1 of 2

DOCUMENT NOT CONSIDERED FINAL UNLESS ALL SIGNATURES COMPLETED

Electrical and Programming Details for: **NC 24-87 (N. Bragg Boulevard) at McKenzie Road/New Street**

Prepared In the Offices of: **Transporatio Mobility and Safety Solutions**

Division 6 Cumberland County Spring Lake

PLAN DATE: February 2016 REVIEWED BY: DTJ

PREPARED BY: James Peterson REVIEWED BY:

REVISIONS INIT. DATE

Seal of Keith M. Mims, Professional Engineer, No. 036880

DocuSigned by: Keith M. Mims 3/17/2016

750 N. Greenfield Pkwy, Garner, NC 27529

SIG. INVENTORY NO. 06-0700

I:\Projects\2016\16-18
 S:\IT\551\16-18\Sigs\Signal\work\kg\060700_sml.ele_xxx.dgn
 J.peterson