

# ECONOLITE ASC/3-2070 RAILROAD PREEMPT PROGRAMMING DETAIL

(program controller as shown)

- From Main Menu select **4. PREEMPTOR/TSP**
- From PREEMPTOR/TSP/SCP Submenu select **1. PREEMPT PLAN 1-10**

Place cursor in [ ] next to Preempt Plan and press 1. Then press the right cursor arrow and toggle the controller to YES. Next cursor down. This will select Railroad Preempt #1.

PREEMPT PLAN [ 1 ]	ENABLE....YES
VEH/PED 1 2 3 4 5 6 7 8 9 0 1 2 3 4 5 6	
OVERLAP A B C D E F G H I J K L M N O P	
TRKCLR V . . . . . X . . . . .	
TRKCLR OF1 . . . . . X X X . . . . .	
ENA TRL . . . . .	
DWEL VEH . . . . .	
DWEL PED . . . . .	
DWEL OLP . . . . .	
CYC VEH . X . . X X X . . . . .	
CYC PED . . . . .	
CYC OLP . . . . F1 . . . . .	
EXIT PH . . X . . . X . . . . .	
EXIT CAL . . . . .	
SP FUNC . . . . .	

ENABLE... YES IPMT OVRIDE.XI INTERLOCK. NO  
 DET LOCK... XIDELAY.. 0IINHIBIT... 0  
 OVERRIDE FL. .IDURATION 0ICLR-GRN... NO  
 TERM OLP. NOIPC>YEL YESITERM PH NO  
 PED DARK.. NOITC RESRV YESIDWELL FL OFF  
 LINK PMT...OIX FLCOLR REDIEXIT OPT. OFF  
 X TMG PLN...OIRE-SERV.. 0IFLT TYPE.HARD  
 FREE DUR PMTIR1 NOIR2 NOIR3 NOIR4 NO  
 --TIMING----WALKIPED CLIMN GRI YELI RED  
 ENTRANCE TM. 11 101 1125.5125.5  
 -----MIN GRIEXT GRIMX GRI YELI RED  
 TRACK CLEAR 101 01 0125.5125.5  
 -----MIN DLIPMTEXTIMX TMI YELI RED  
 DWL/CYC-EXIT 71 0.01 0125.5125.5  
 PMT ACTIVE OUT..ON PMT ACT DWELL...NO  
 OTHER - PRI PMT.OFF NON-PRI PMT.....OFF  
 INH EXT TIME... 0.0 PED PR RETURN...OFF  
 PRIORITY RETURN.OFF QUEUE DELAY.... OFF  
 COND DELAY.....OFF

PHASES	1	2	3	4	5	6	7	8
PR RTN%	0	0	0	0	0	0	0	0
PHASES	9	10	11	12	13	14	15	16
PR RTN%	0	0	0	0	0	0	0	0

# RAILROAD PREEMPTION WIRING DETAIL

(wire as shown below)

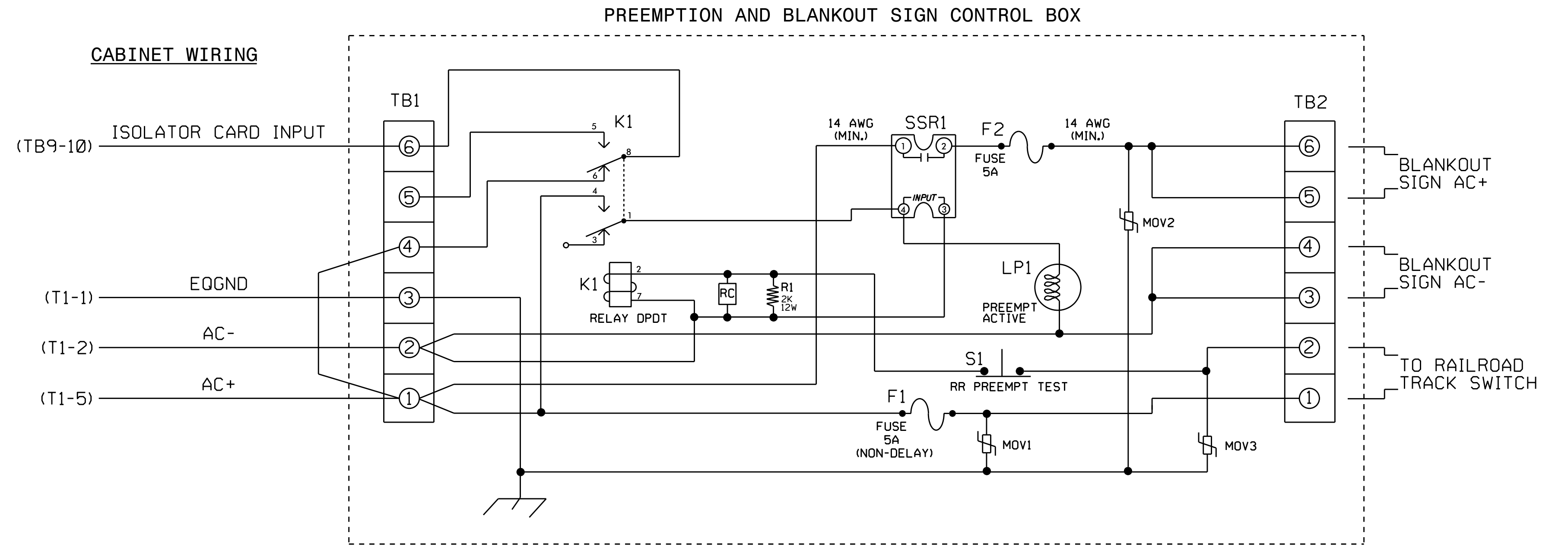

## NOTES

- Relay K1 is shown in the energized (Preempt not active) normal operation state.
- Relay K1 is a DPDT with 120VAC coil with octal base.
- Relay SSR1 is a SPST (normally open) Solid State Relay with AC input and AC (25 amp) output.
- AC Isolator Card shall activate preemption upon removal of AC+ from the input (as shown above). To accomplish this set invert dip switch on AC Isolator Card.
- IMPORTANT!!** A jumper must be added between input file terminals J14-E and J14-K if not already present. Also, terminal TB9-12 (on input panel) shall be connected to AC neutral (jumper may have to be added).

## FRONT VIEW

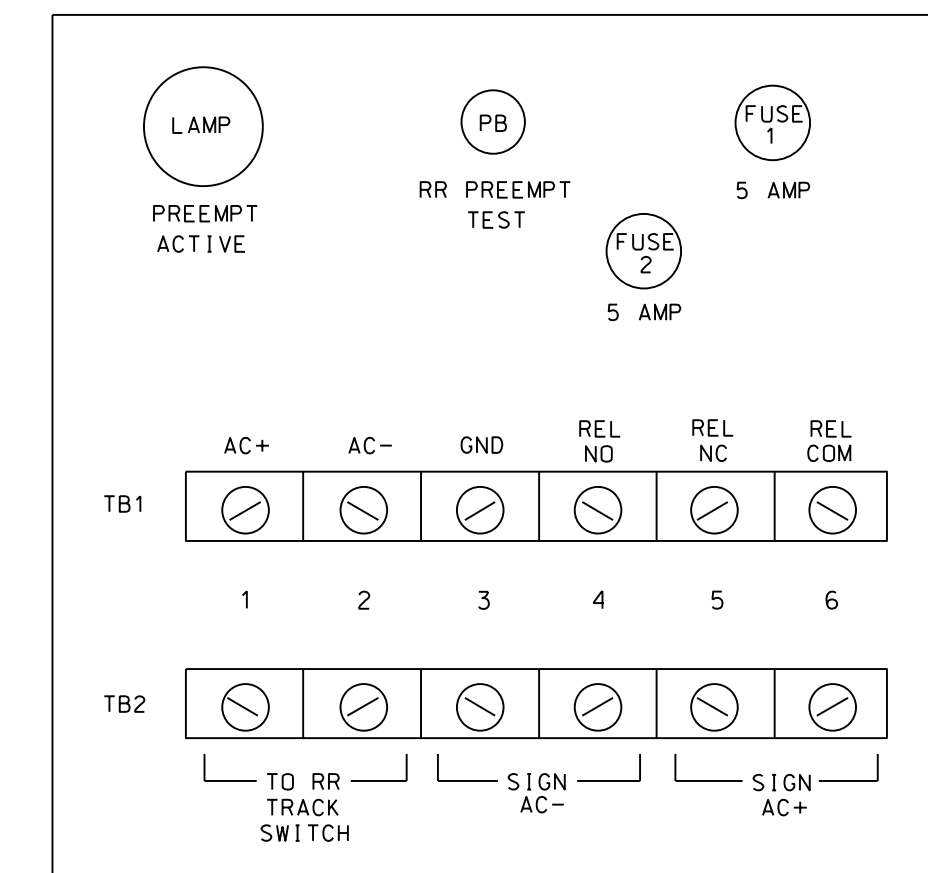

## PREEMPT 1 AC ISOLATOR (MODEL 252) OUTPUT PROGRAMMING DETAIL

(set DIP switches as shown below)

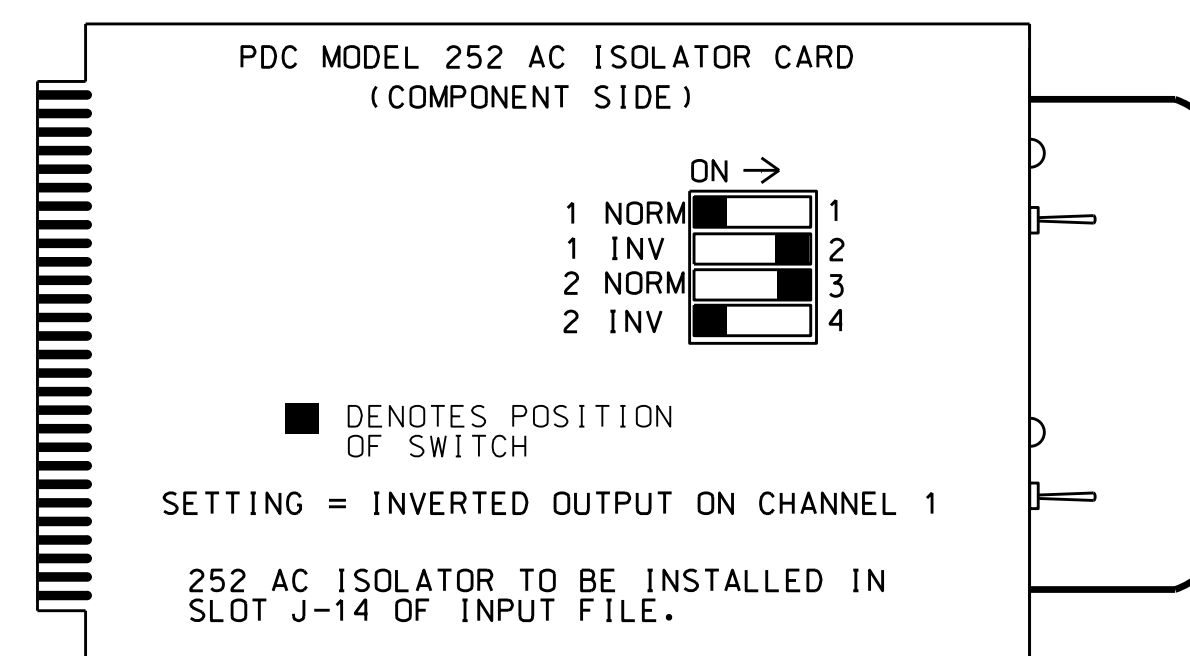

NOTE: IF ANOTHER MANUFACTURER TYPE OF AC ISOLATOR IS USED, OUTPUT PROGRAMMING IS LIKELY NOT TO EQUATE TO THAT SHOWN ABOVE.

THIS ELECTRICAL DETAIL IS FOR THE SIGNAL DESIGN: 06-0364  
 DESIGNED: January 2016  
 SEALED: 10/4/2016  
 REVISED: N/A

Electrical Detail - Sheet 4 of 4

ELECTRICAL AND PROGRAMMING DETAILS FOR: Prepared in the Offices of:  750 N. Greenfield Pkwy, Garner, NC 27529	SR 1403 (S. Reilly Road) at SR 1400 (Cliffdale Road)	DOCUMENT NOT CONSIDERED FINAL UNLESS ALL SIGNATURES COMPLETED
	Division 6 Cumberland County Fayetteville PLAN DATE: September 2016 REVIEWED BY: BAS PREPARED BY: S. Armstrong REVIEWED BY:	SEAL KEITH M. MIMS ENGINEER