

**EDI MODEL 2018ECLIP-NC CONFLICT MONITOR  
PROGRAMMING DETAIL**

(remove jumpers and set switches as shown)

REMOVE DIODE JUMPERS 1-6, 1-9, 1-15, 2-6, 2-9, 2-13, 2-15, 4-14, 6-9, 6-13, 6-15, 9-13, 9-15, and 13-15.

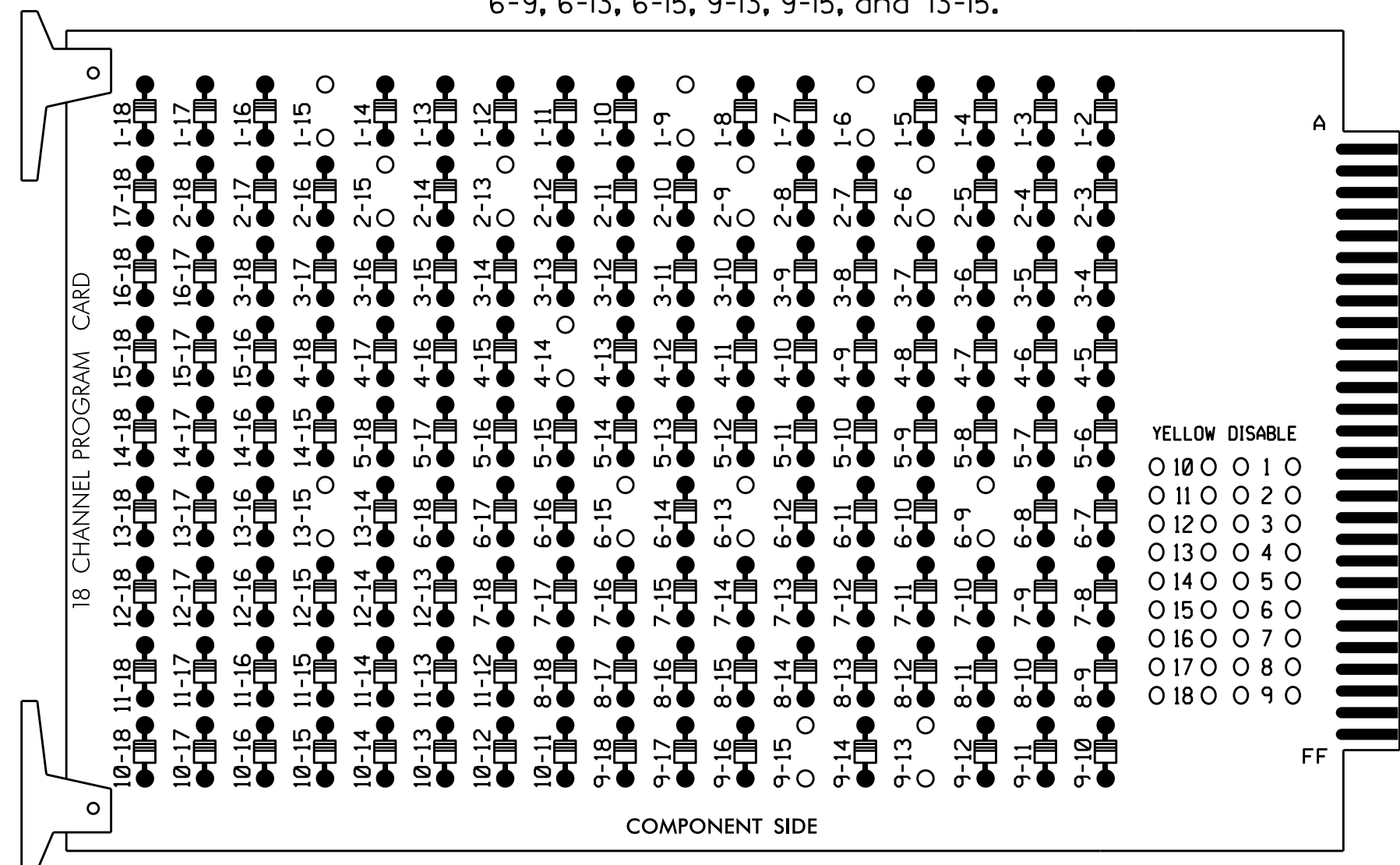

REMOVE JUMPERS AS SHOWN

**NOTES:**

- Card is provided with all diode jumpers in place. Removal of any jumper allows its channels to run concurrently.
- Ensure jumpers SEL2-SEL5 and SEL9 are present on the monitor board.
- Ensure that Red Enable is active at all times during normal operation.
- Integrate monitor with Ethernet network in cabinet.

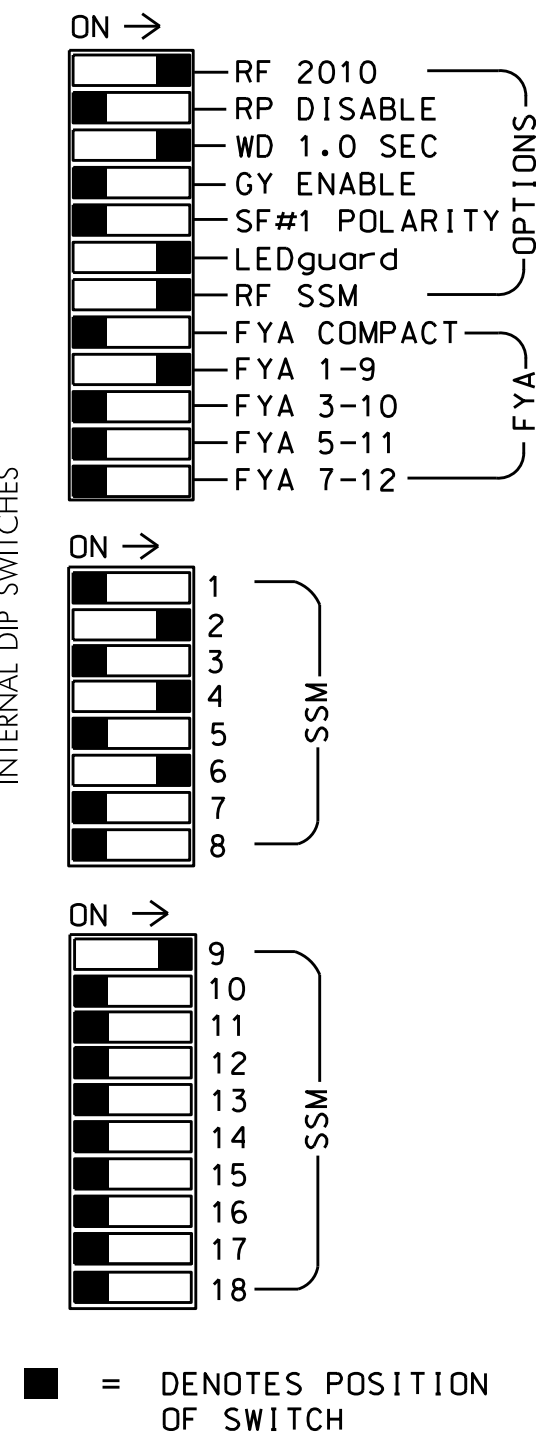

**NOTES**

- To prevent "flash-conflict" problems, insert red flash program blocks for all unused vehicle load switches in the output file. The installer shall verify that signal heads flash in accordance with the Signal Plans.
- Enable Simultaneous Gap-Out for all phases.
- Program phases 2 and 6 for volume density operation.
- Program controller to start up in phase 2 Walk and 6 Walk.
- The cabinet and controller are part of the Fayetteville Signal System.

**EQUIPMENT INFORMATION**

CONTROLLER.....2070E  
 CABINET.....332 W/AUX  
 SOFTWARE.....ECONOLITE ASC/3-2070  
 CABINET MOUNT.....BASE  
 OUTPUT FILE POSITIONS...18 WITH AUX. OUTPUT FILE  
 LOAD SWITCHES USED.....S1,S2,S3,S5,S6,S8,S9,AUX S1  
 PHASES USED.....1,2,2PED,4,4PED,6,6PED  
 OVERLAP "A".....\*  
 OVERLAP "B".....NOT USED  
 OVERLAP "C".....NOT USED  
 OVERLAP "D".....NOT USED

\* See overlap programming detail on sheet 2

**SIGNAL HEAD HOOK-UP CHART**

LOAD SWITCH NO.	S1	S2	S3	S4	S5	S6	S7	S8	S9	S10	S11	S12	AUX S1	AUX S2	AUX S3	AUX S4	AUX S5	AUX S6
CMU CHANNEL NO.	1	2	13	3	4	14	5	6	15	7	8	16	9	10	17	11	12	18
PHASE	1	2	2 PED	3	4	4 PED	5	6	6 PED	7	8	8 PED	OLA	OLB	SPARE	OLC	OLD	SPARE
SIGNAL HEAD NO.	11	21,22	P21, P22	NU	41,42, 43	P41,P42 P43,P44	NU	61,62	P61, P62	NU	NU	NU	11	NU	NU	NU	NU	NU
RED		128			101			134										
YELLOW	*	129			102			135										
GREEN		130			103			136										
RED ARROW													A121					
YELLOW ARROW													A122					
FLASHING YELLOW ARROW													A123					
GREEN ARROW	127																	
Hand icon			113		104			119										
Person icon			115		106			121										

NU = Not Used  
 \* Denotes install load resistor. See load resistor installation detail below.  
 ★ See pictorial of head wiring in detail below.

**INPUT FILE POSITION LAYOUT**

(front view)

FILE	1	2	3	4	5	6	7	8	9	10	11	12	13	14
U	∅ 1	∅ 2	∅ 3	∅ 4	∅ 5	∅ 6	∅ 7	∅ 8	∅ 9	∅ 10	∅ 11	∅ 12	∅ 13	∅ 14
L	1A	2A	∅ 3	∅ 4	∅ 5	∅ 6	∅ 7	∅ 8	∅ 9	∅ 10	∅ 11	∅ 12	∅ 13	∅ 14
U	NOT USED	∅ 2	∅ 3	∅ 4	∅ 5	∅ 6	∅ 7	∅ 8	∅ 9	∅ 10	∅ 11	∅ 12	∅ 13	∅ 14
L	∅ 1	∅ 2	∅ 3	∅ 4	∅ 5	∅ 6	∅ 7	∅ 8	∅ 9	∅ 10	∅ 11	∅ 12	∅ 13	∅ 14

EX.: 1A, 2A, ETC. = LOOP NO.'S  
 FS = FLASH SENSE  
 ST = STOP TIME

⊗ Wired Input - Do not populate slot with detector card

**INPUT FILE CONNECTION & PROGRAMMING CHART**

LOOP NO.	LOOP TERMINAL	INPUT FILE POS.	PIN NO.	DETECTOR NO.	NEMA PHASE	CALL	EXTEND TIME	DELAY TIME	DETECTOR TYPE
1A	TB2-1,2	I1U	56	1	1	YES		15	S
	-	J4U	48	26	6	YES		3	G
2A	TB2-5,6	I2U	39	2	2	YES			N
2B	TB2-7,8	I2L	43	12	2	YES			N
4A	TB4-9,10	I6U	41	4	4	YES			S
4B	TB4-11,12	I6L	45	14	4	YES			S
4C	TB6-1,2	I7U	65	34	4	YES		10	S
4D	TB6-3,4	I7L	78	44	4	YES		15	S
PED PUSH BUTTONS									
P21,P22	TB8-4,6	I12U	67	PED 2	2 PED				
P41,P42 P43,P44	TB8-5,6	I12L	69	PED 4	4 PED				
P61,P62	TB8-7,9	I13U	68	PED 6	6 PED				

NOTE:  
 INSTALL DC ISOLATORS IN INPUT FILE SLOTS 112 AND 113.

^ Add jumper from I1-W to J4-W, on rear of input file.

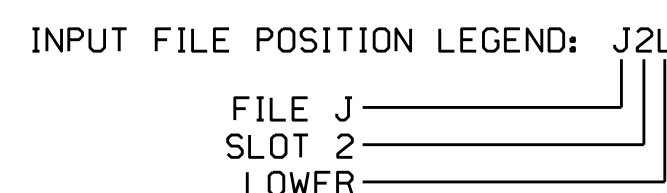

**FYA SIGNAL WIRING DETAIL**

(wire signal head as shown)

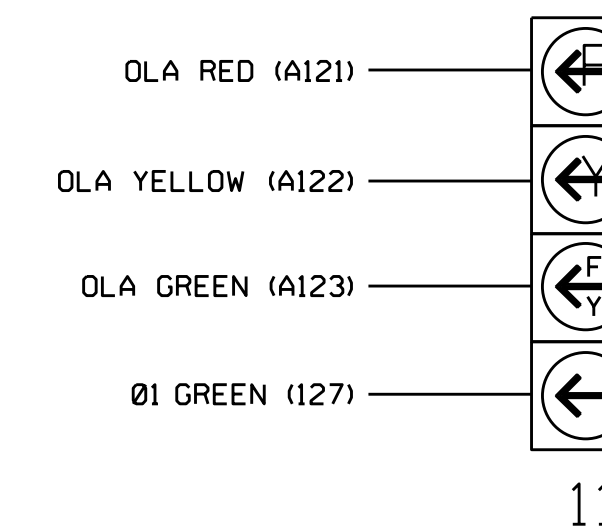

**LOAD RESISTOR INSTALLATION DETAIL**

(install resistor as shown below)

VALUE (ohms)	WATTAGE
1.5K - 1.9K	25W (min)
2.0K - 3.0K	10W (min)

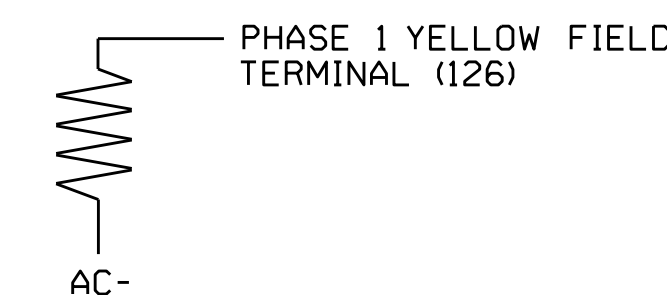

**SPECIAL DETECTOR NOTE**

For detection zone 6A, install a microwave detection system for vehicle detection. Perform installation according to manufacturer's directions and NCDOT engineer-approved mounting locations to accomplish the detection scheme shown on the Signal Design Plan.

THIS ELECTRICAL DETAIL IS FOR THE SIGNAL DESIGN: 06-0281  
 DESIGNED: December 2015  
 SEALED: 5/31/2016  
 REVISED: N/A

Electrical and Programming Details for: SR 1437 (Santa Fe Drive) at SR 1007 Southbound Ramps (All American Freeway)

Division 6 Cumberland County Fayetteville

PLAN DATE: October 2016 REVIEWED BY: BAS

PREPARED BY: S. Armstrong REVIEWED BY:

REVISIONS: INIT. DATE

750 N. Greenfield Pkwy, Garner, NC 27529

Seal of Keith M. Mims, Professional Engineer, No. 036880

DocuSigned by: Keith M. Mims 10/17/2016

SIG. INVENTORY NO. 06-0281