

# ECONOLITE ASC/3-2070 RAILROAD PREEMPT PROGRAMMING DETAIL

(program controller as shown)

- From Main Menu select 4. PREEMPTOR/TSP
- From PREEMPTOR/TSP/SCP Submenu select 1. PREEMPT PLAN 1-10

Place cursor in [ ] next to Preempt Plan and press 1. Then press the right cursor arrow and toggle the controller to YES. Next cursor down. This will select Railroad Preempt #1.

PREEMPT PLAN [ 1 ]	ENABLE....YES
VEH/PED 1 2 3 4 5 6 7 8 9 0 1 2 3 4 5 6	
OVERLAP A B C D E F G H I J K L M N O P	
TRKCLR V X . . . . X . . . . .	
TRKCLR D F1.F1 . . . . .	
ENA TRL . . . . .	
DWEL VEH . . . . .	
DWEL PED . . . . .	
DWEL OLP . . . . .	
CYC VEH . . X X . . . . .	
CYC PED . . . . .	
CYC OLP . . . . .	
EXIT PH . X . . . . X . . . . .	
EXIT CAL . . . . .	
SP FUNC . . . . .	

ENABLE... YESIPMT OVRIDE.XIINTERLOCK. NO  
 DET LOCK... XIDELAY.. OIINHIBIT... 0  
 OVERRIDE FL. .IDURATION OICLR-GRN... NO  
 TERM OLP. NOIPC>YEL NOITERM PH NO  
 PED DARK.. NOITC RESRV YESIDWELL FL OFF  
 LINK PMT...OIX FLCOLR REDIXIT OPT. OFF  
 X TMG PLN...OIRE-SERV.. OIFLT TYPE.HARD  
 FREE DUR PMTIR1 NOIR2 NOIR3 NOIR4 NO  
 --TIMING----WALKIPED CLIMN GRI YELI RED  
 ENTRANCE TM. 255I 255I 1125.5I25.5  
 -----MIN GRIEXT GRIMX GRI YELI RED  
 TRACK CLEAR 19I 0I 0I25.5I25.5  
 -----MIN DLIPMTEXTIMX TMI YELI RED  
 DWL/CYC-EXIT 10I 0.0I 0I25.5I25.5  
 PMT ACTIVE OUT..ON PMT ACT DWELL...NO  
 OTHER - PRI PMT.OFF NON-PRI PMT....OFF  
 INH EXT TIME... 0.0 PED PR RETURN...OFF  
 PRIORITY RETURN.OFF QUEUE DELAY.... OFF  
 COND DELAY.....OFF

PHASES	1	2	3	4	5	6	7	8
PR RTN%	0	0	0	0	0	0	0	0
PHASES	9	10	11	12	13	14	15	16
PR RTN%	0	0	0	0	0	0	0	0

# RAILROAD PREEMPTION WIRING DETAIL

(wire as shown below)

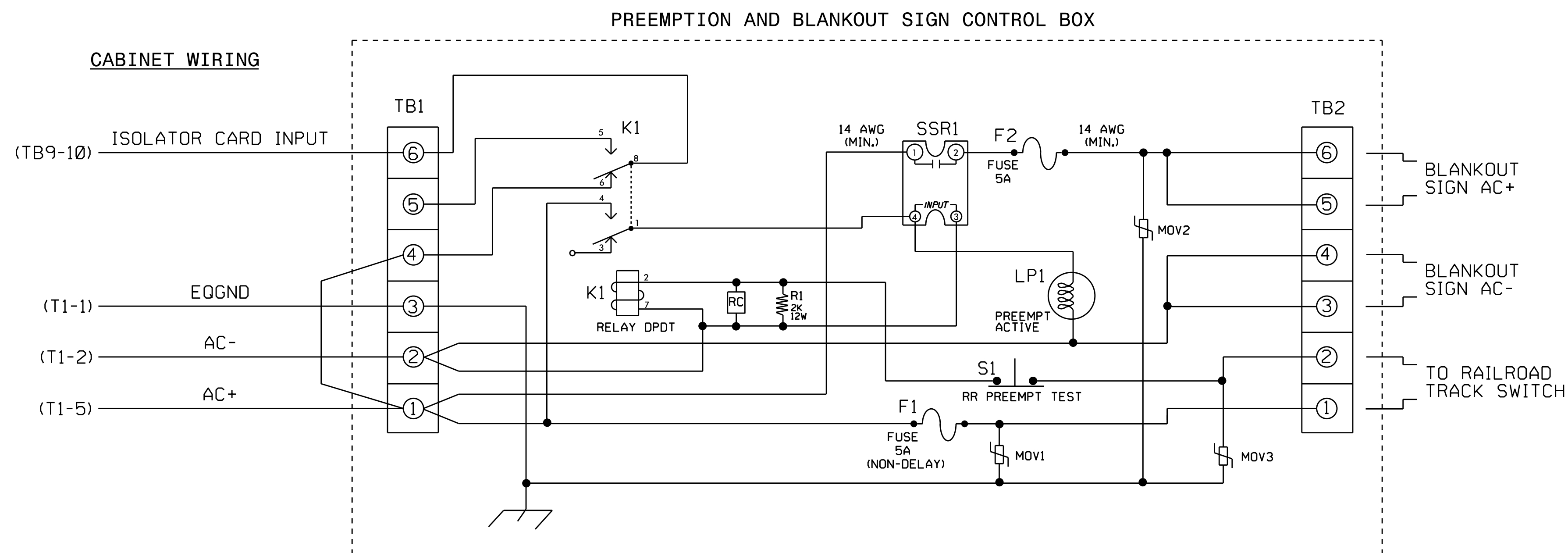

## NOTES

- Relay K1 is shown in the energized (Preempt not active) normal operation state.
- Relay K1 is a DPDT with 120VAC coil with octal base.
- Relay SSR1 is a SPST (normally open) Solid State Relay with AC input and AC (25 amp) output.
- AC Isolator Card shall activate preemption upon removal of AC+ from the input (as shown above). To accomplish this set invert dip switch on AC Isolator Card.
- IMPORTANT!! A jumper must be added between input file terminals J14-E and J14-K if not already present. Also, terminal TB9-12 (on input panel) shall be connected to AC neutral (jumper may have to be added).

## FRONT VIEW

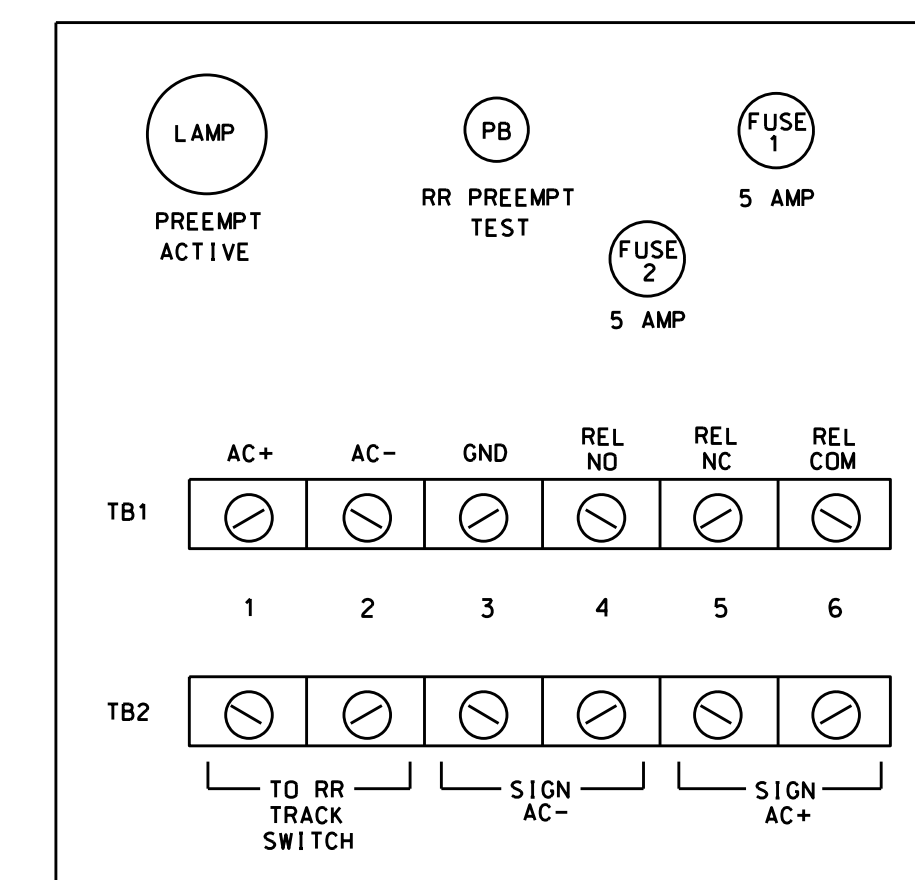

## PREEMPT 1 AC ISOLATOR (MODEL 252) OUTPUT PROGRAMMING DETAIL

(set DIP switches as shown below)

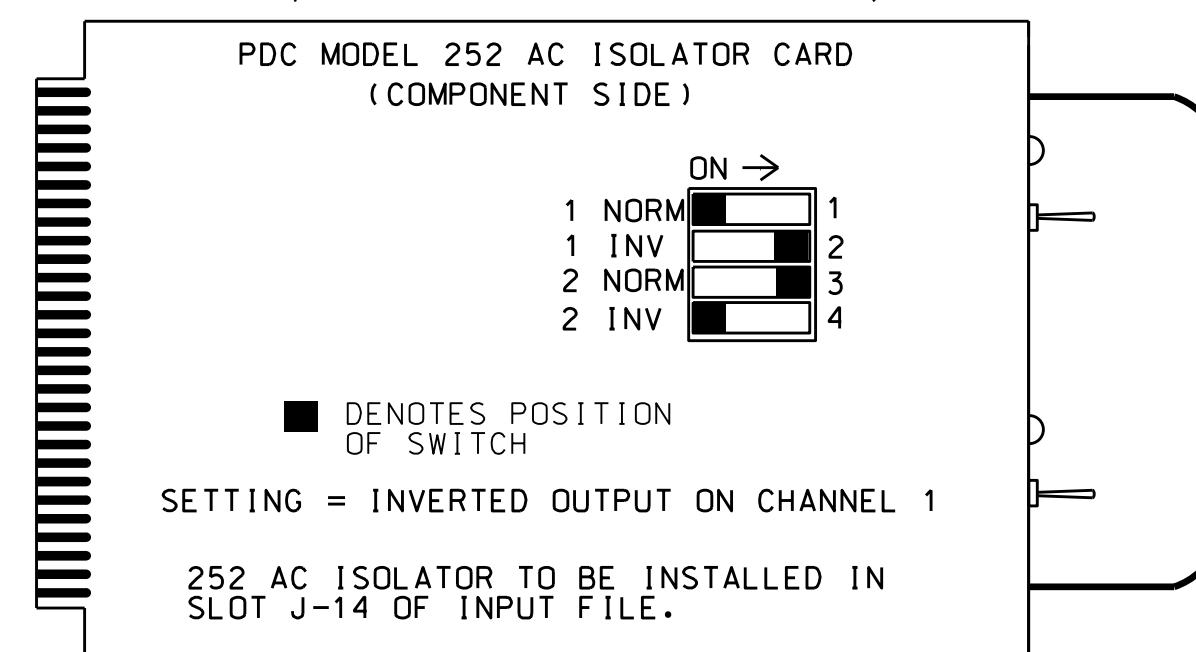

NOTE: IF ANOTHER MANUFACTURER TYPE OF AC ISOLATOR IS USED, OUTPUT PROGRAMMING IS LIKELY NOT TO EQUATE TO THAT SHOWN ABOVE.

THIS ELECTRICAL DETAIL IS FOR THE SIGNAL DESIGN: 06-0016  
 DESIGNED: April 2016  
 SEALED: 10-14-16  
 REVISED: N/A

Electrical Detail Sheet 3 of 3

Prepared In the Offices of:  
 TRANSPORTATION MOBILITY AND SAFETY DIVISION  
 FEDERAL BUREAU OF INVESTIGATION  
 Signal Management Section  
 750 N. Greenfield Pkwy, Garner, NC 27529

DETAILS FOR: I-95 Business / US 301 (Eastern Boulevard) at SR 2299 (Russell Street)

Division 6 Cumberland County Fayetteville

PLAN DATE: October 2016 REVIEWED BY: BAS

PREPARED BY: James Peterson REVIEWED BY:

REVISIONS INIT. DATE

Documented by: Keith M. Mims 10/20/2016

SEAL NORTH CAROLINA PROFESSIONAL ENGINEER KEITH M. MIMS 036880

SIG. INVENTORY NO. 06-0016

18-001-2016 08-57 S:\IT\ASIS\18-001-2016\work\hgr\asig\Map\Peterston\060016\_sml.ele\_xxx.dgn J:\peterson