

PROJECT REFERENCE NO. U-4910B		SHEET NO. 8	
RW SHEET NO.		HYDRAULICS ENGINEER	
ROADWAY DESIGN ENGINEER		HYDRAULICS ENGINEER	
Prepared in the Office of:		NC FIRM LICENSE No. F-0342 701 Corporate Center Drive, Suite 415 Raleigh, NC 27607 (919) 854-6200 • (919) 854-6259(FAX)	
AECOM		AECOM	
<p align="center">DOCUMENT NOT CONSIDERED FINAL UNLESS ALL SIGNATURES COMPLETED</p>			

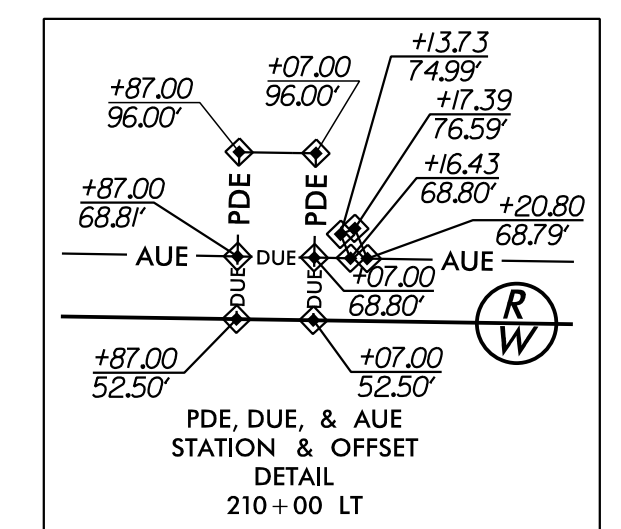
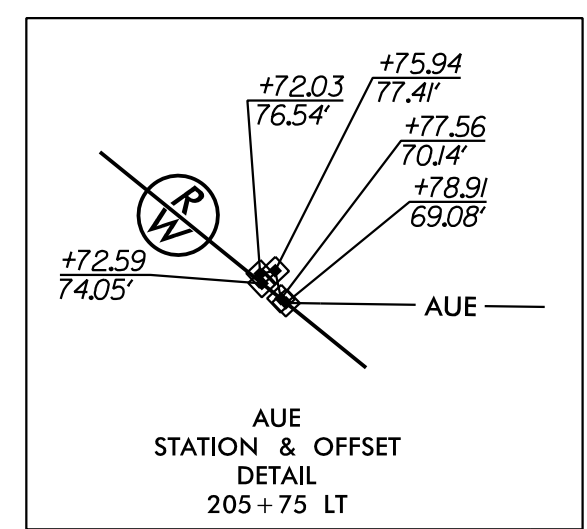
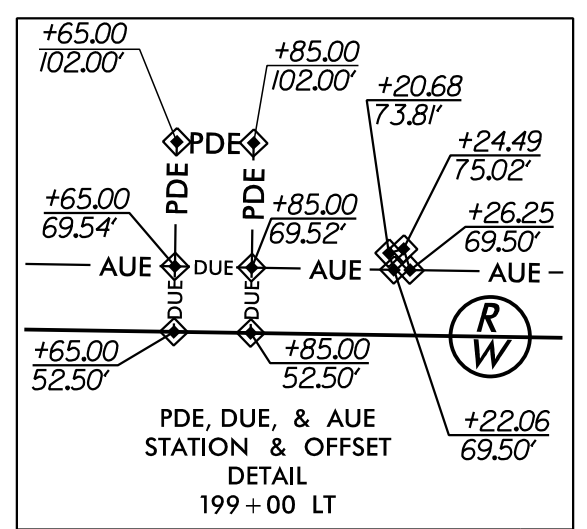

37
FIRST UNION NATNL BNK TRUSTEES
DB III4 PG 207

NAD 83/NSRS 2007

MATCHLINE -L- STA. 198+00 SEE PLAN SHEET 7

MATCHLINE STA. 212+00 SEE PLAN SHEET 9

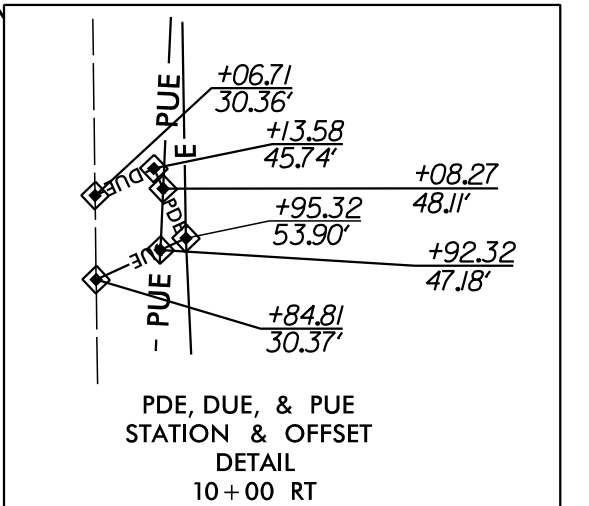
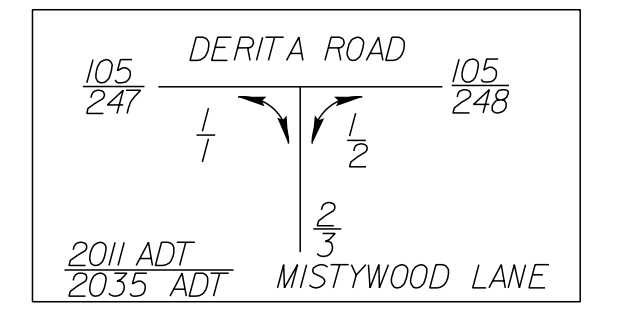
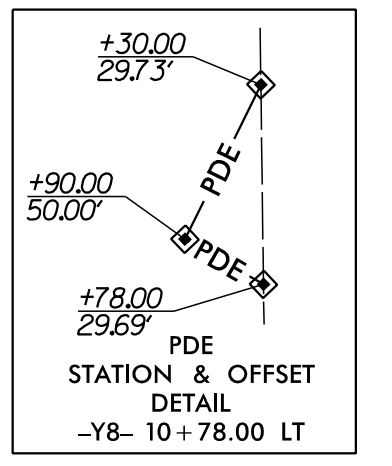
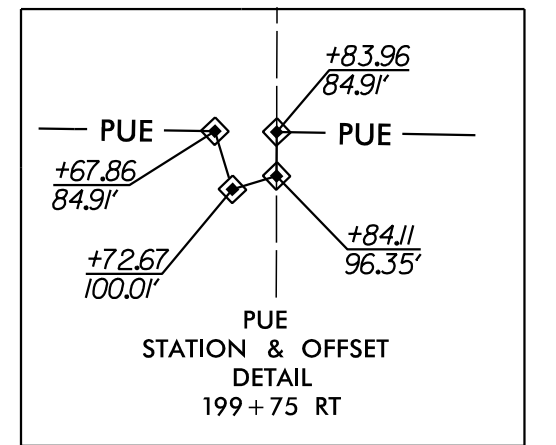
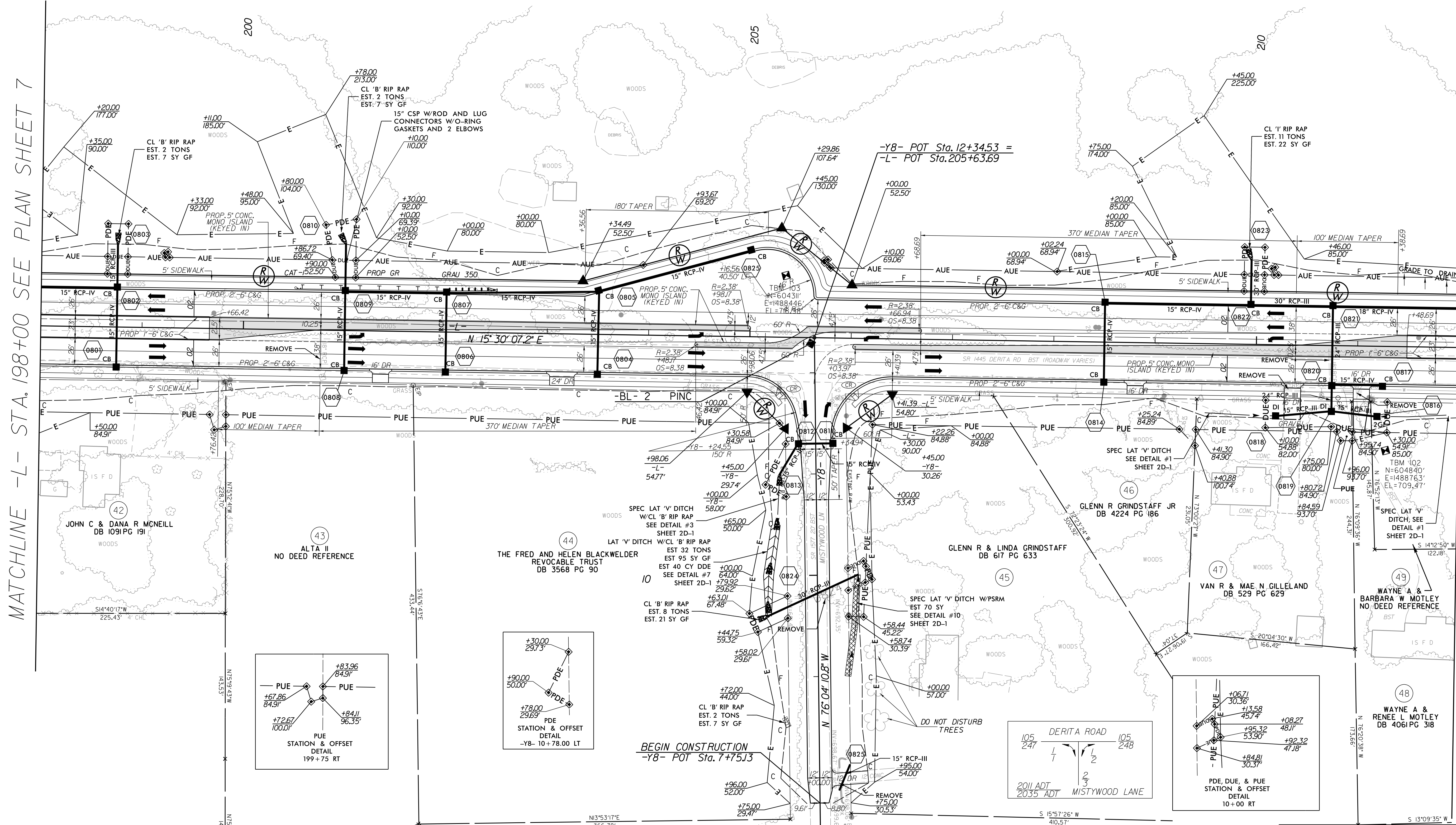

FOR -L- PROFILE SEE SHEET 13
FOR -Y8- PROFILE SEE SHEET 15

REVISIONS

Revisions:

Drawn: R:\Roadway\Proj\U4910B\RD\RD\101018.dwg
User: schmid
Date: 9/19/2016
Time: 2:47:39 PM