

DRAINAGE DETAILS

PROJECT REFERENCE NO. <i>U-4910B</i>	SHEET NO. <i>2D-1</i>
RW SHEET NO.	
ROADWAY DESIGN ENGINEER	HYDRAULICS ENGINEER
Prepared in the Office of: AECOM NC FIRM LICENSE No. F-0342 701 Corporate Center Drive, Suite 475 Raleigh, NC 27607 (919) 854-6200 • (919) 854-6259(FAX)	
DOCUMENT NOT CONSIDERED FINAL UNLESS ALL SIGNATURES COMPLETED	

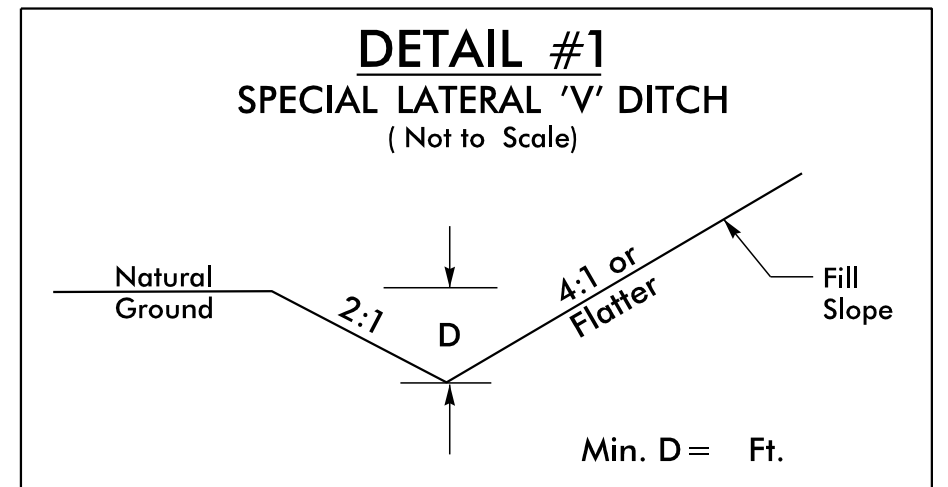

FROM STA. 161+50 TO STA. 166+50 -L- LT
 FROM STA. 176+50 TO STA. 178+00 -L- LT
 FROM STA. 184+00 TO STA. 187+26 -L- RT
 FROM STA. 209+50 TO STA. 210+20 -L- RT
 FROM STA. 211+20 TO STA. 215+90 -L- RT
 FROM STA. 14+00 TO STA. 14+50 -Y5- RT
 FROM STA. 11+30 TO STA. 11+80 -Y9- RT

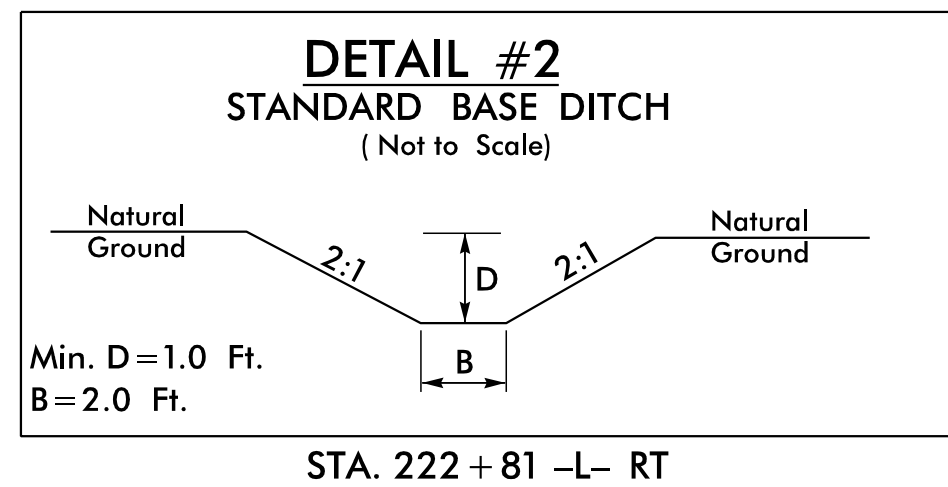

STA. 222+81 -L- RT

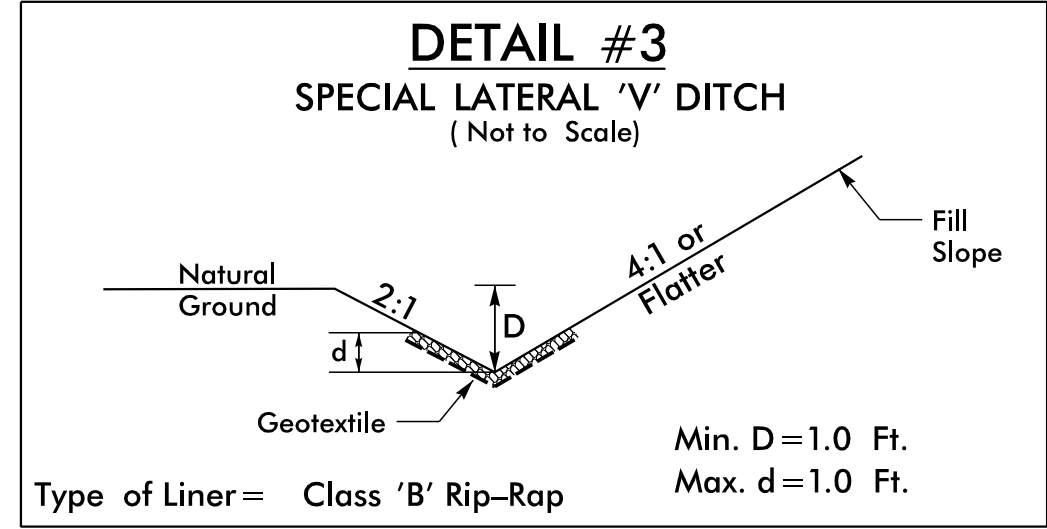

FROM STA. 191+40 TO STA. 192+50 -L- RT
 FROM STA. 10+50 TO STA. 11+00 -Y8- LT

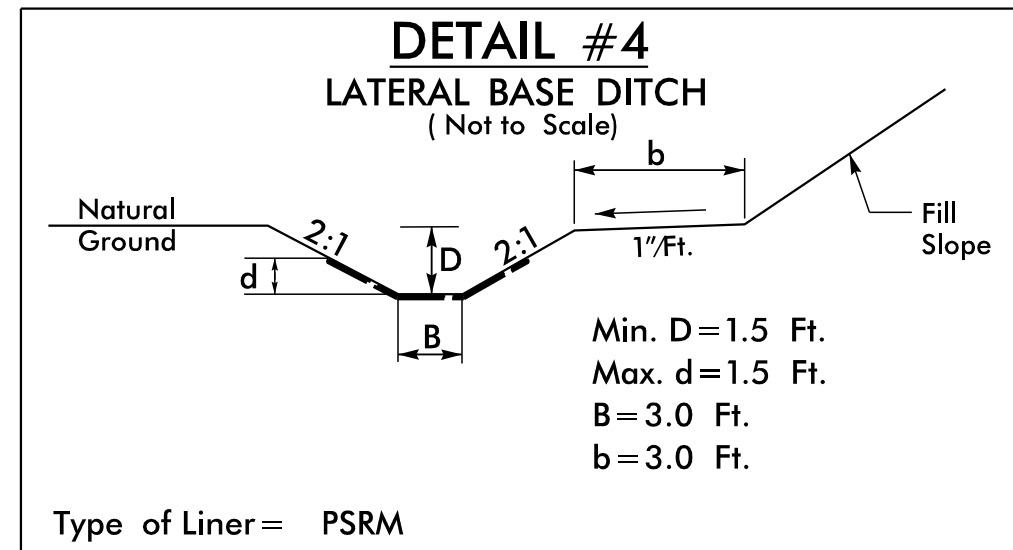

FROM STA. 187+26 TO STA. 190+10 -L- RT

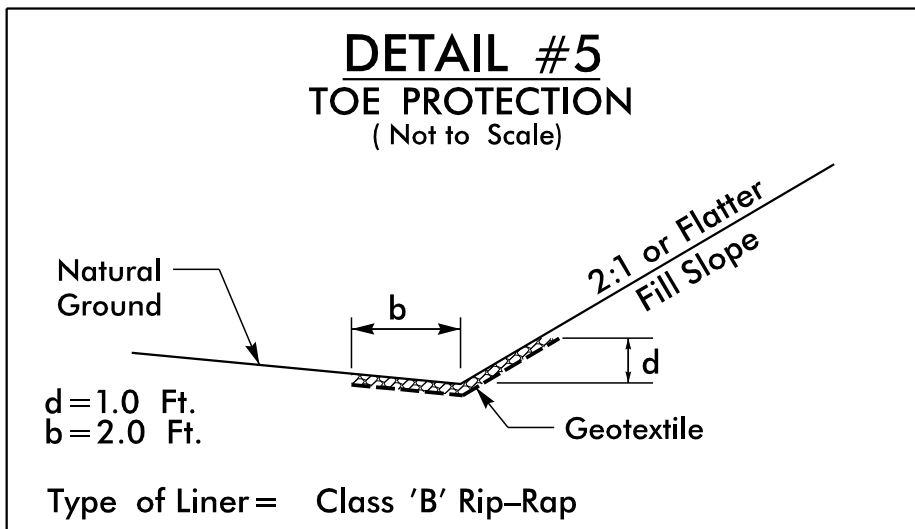

FROM STA. 187+50 TO STA. 190+00 -L- LT

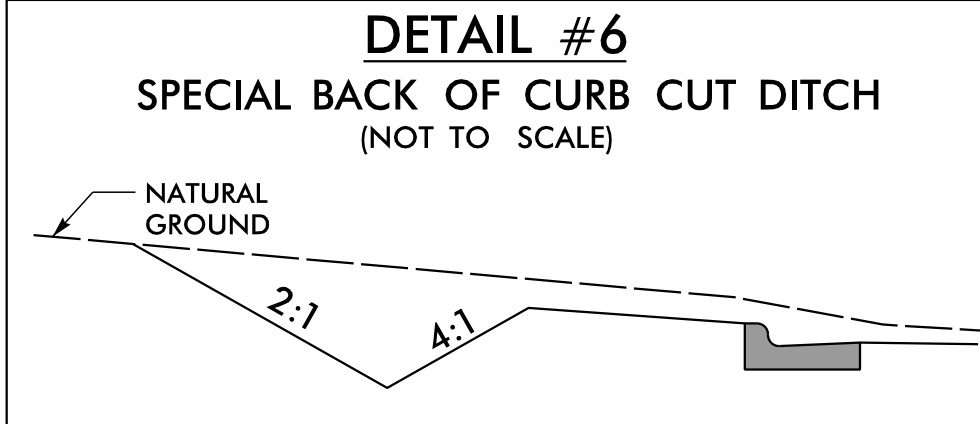

FROM STA. 167+00 TO STA. 167+50 -L- RT
 FROM STA. 159+30 TO STA. 161+50 -L- RT

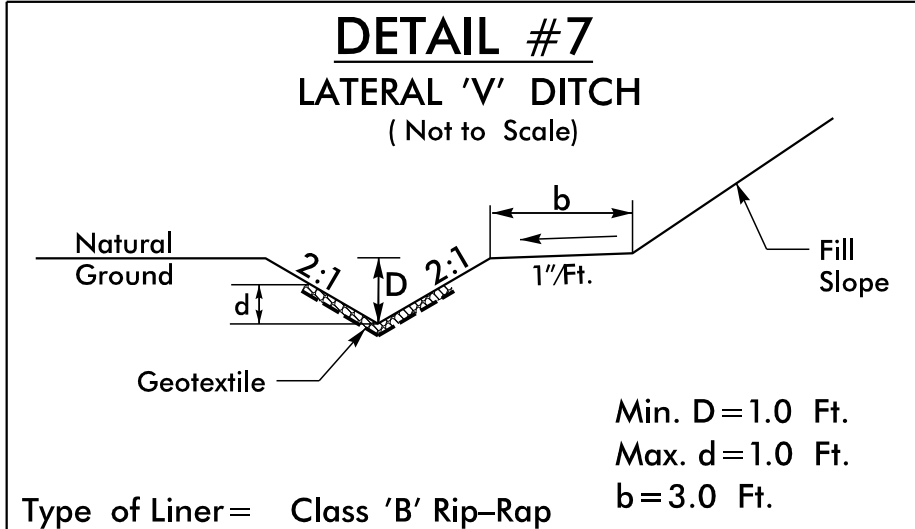

FROM STA. 9+60 TO STA. 10+50 -Y8- LT

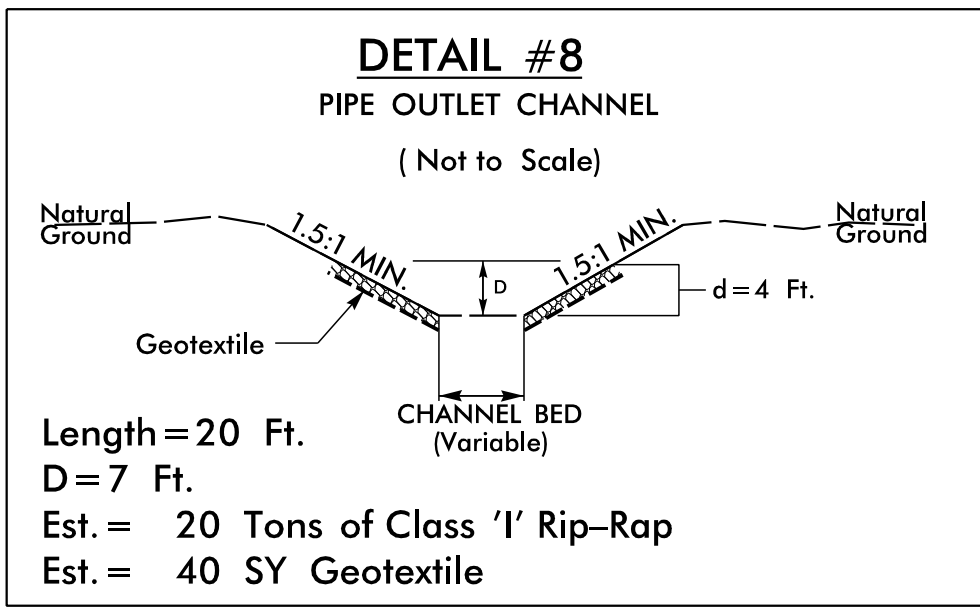

FROM STA. 186+70 TO STA. 186+90 -L- LT

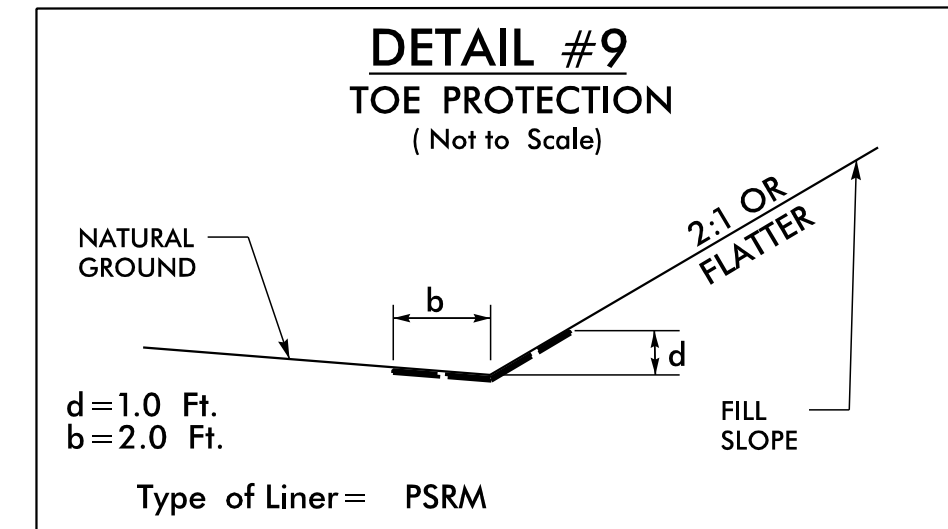

FROM STA. 216+00 TO STA. 218+00 -L- LT

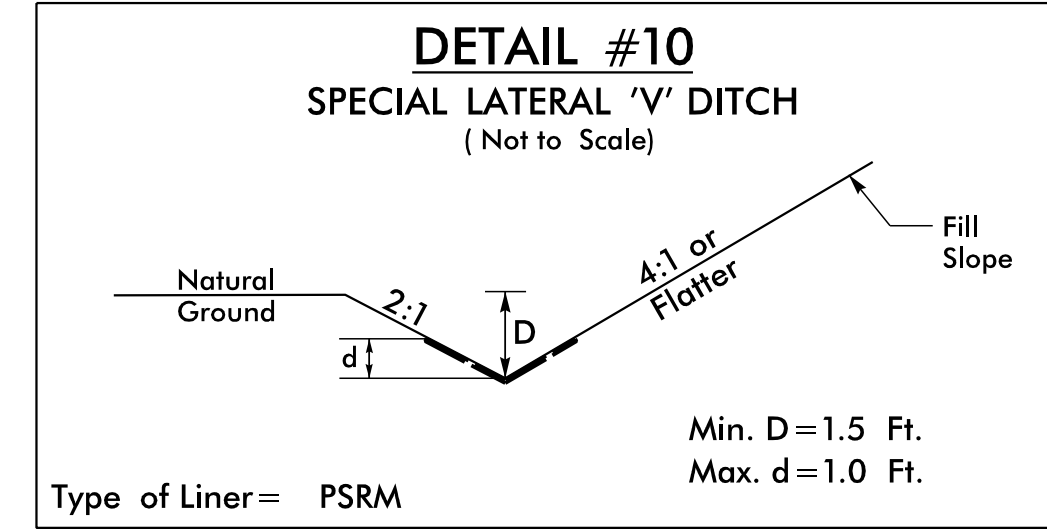

FROM STA. 9+00 TO STA. 10+00 -Y8- RT

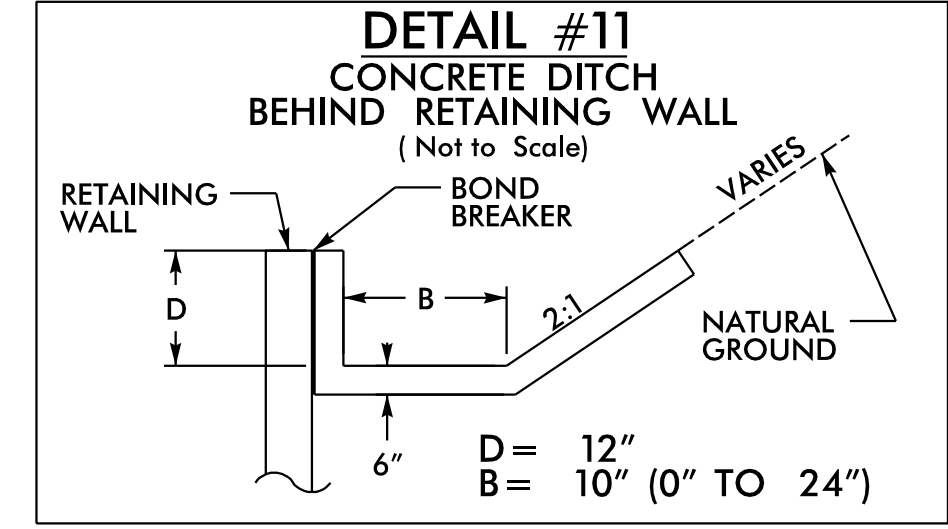

FROM STA. 172+15 TO STA. 179+60 -L- RT

REVISIONS

Revisions:

Drawn: R:\Roadway\Proj\4910B\RD\detail\012D.dwg
 User: schneid
 Date: 1/12/2017
 Time: 10:50:46 AM