

PLAN OF SPAN A AND PARTIAL PLAN OF SPAN B  
(STAGE II)  
\* RADIAL DIMENSION

PROJECT NO. U-4910A  
CABARRUS COUNTY  
STATION: 147+80.00 -L-  
SHEET 3 OF 4

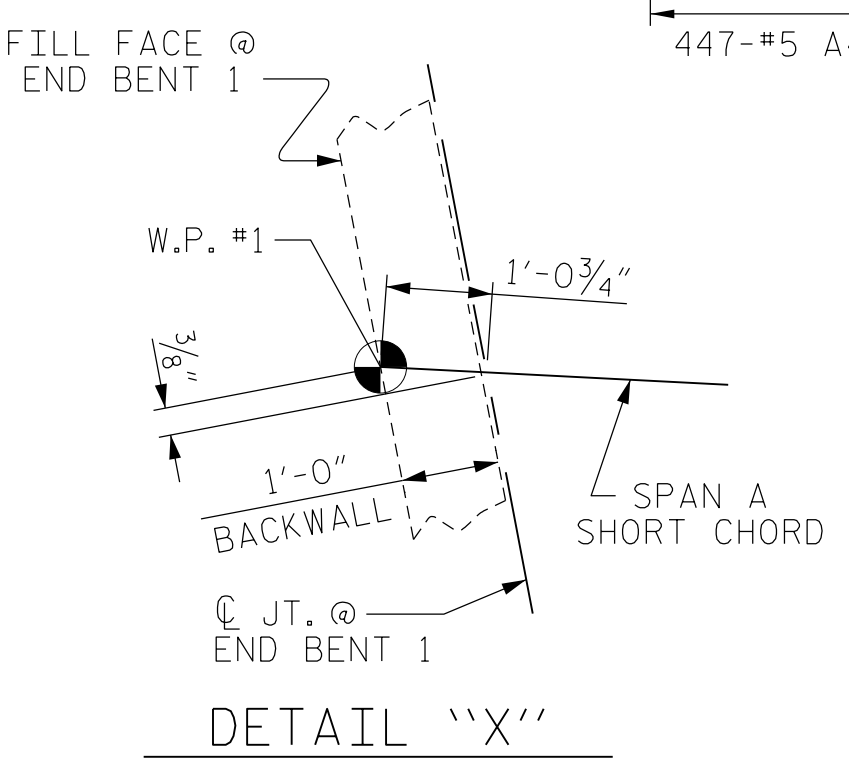

- NOTES**
- FOR TRANSVERSE CONSTRUCTION JOINT DETAIL AND LOCATION, SEE "POURING SEQUENCE" SHEET.
  - FOR 3 BAR METAL RAIL REINFORCING, SEE "3 BAR METAL RAIL" SHEET.
  - \* FOR SIDEWALK REINFORCING, SEE "SIDEWALK DETAILS" SHEET.
  - #5 "A" BARS ARE TO BE PLACED PERPENDICULAR TO AND ALONG THE LONG CHORD
  - #5 D1 DOWELS SHALL BE PLACED IN THE SAME HORIZONTAL PLANE AS THE TOP AND BOTTOM SLAB REINFORCING STEEL.
  - FOR PLACEMENT OF #4 J1 BAR, SEE "EXPANSION JOINT SEAL DETAILS" SHEETS.

DRAWN BY : N.K. BROWN DATE : 7/2016  
CHECKED BY : K.H. COMPTON DATE : 7/2016  
DESIGNED BY : N.K. BROWN DATE : 2/2016

**AECOM**  
AECOM TECHNICAL SERVICES, INC.  
701 CORPORATE CENTER DRIVE, SUITE 475  
RALEIGH, NC 27607  
(919) 854-6200 www.aecom.com  
AECOM License No. F-0342

11/30/2016

NORTH CAROLINA PROFESSIONAL SEAL  
030474  
JOHN C. MORRISON  
ENGINEER  
A2FD0E142C2F4A8

STATE OF NORTH CAROLINA  
DEPARTMENT OF TRANSPORTATION  
RALEIGH

SUPERSTRUCTURE  
PLAN OF SPANS  
STAGE II

REVISIONS						SHEET NO.
NO.	BY:	DATE:	NO.	BY:	DATE:	
1			3			S-13
2			4			TOTAL SHEETS 55

DOCUMENT NOT CONSIDERED FINAL UNLESS ALL SIGNATURES COMPLETED

DATE: 11/30/2016  
TIME: 10:07:41 AM

USER: N:\aecom\030474\14007\_Technical\08\_Structural\08\_StageII\U4910A\_S13\_P503.dgn