

NEW AERIAL SPLICE ENCLOSURE AT
SR 1445 (DERITA RD) AND
THUNDER RD /PNG DRIVEWAY
SIG. INV. # 10-2010

COLOR CODE TIA/EIA 598-A		LEGEND	
(1) BLUE	(7) RED	X = NEW FUSION SPLICE INDIVIDUAL FIBER	
(2) ORANGE	(8) BLACK	C = CAP, COIL, AND SEAL	
(3) GREEN	(9) YELLOW		
(4) BROWN	(10) VIOLET		
(5) SLATE	(11) ROSE		
(6) WHITE	(12) AQUA		

Notes:
Unused fibers left coiled and stored in splice tray.
Unused Buffer Tubes left coiled and stored in splice tray.

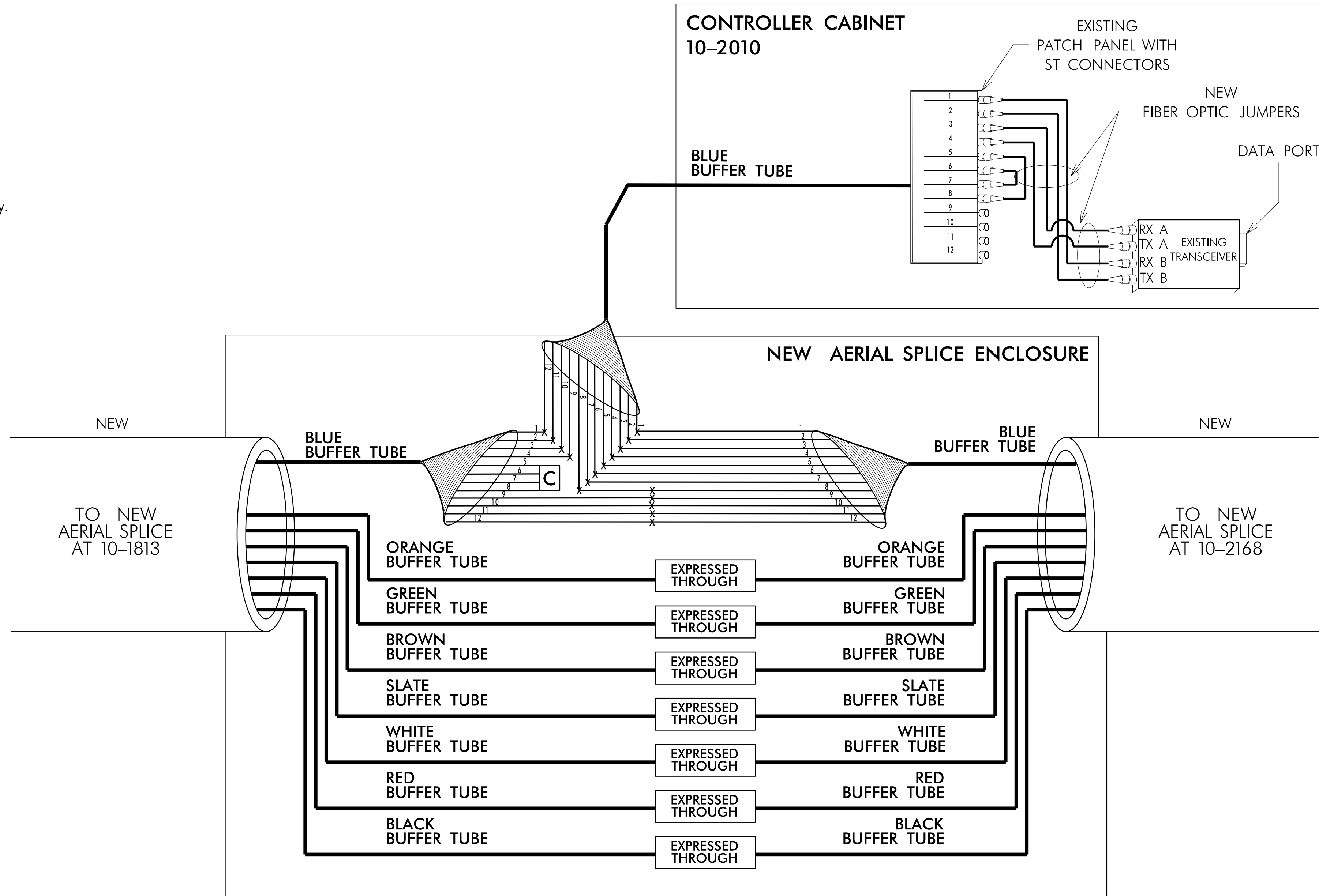

INCLUDE ON THE COVER OF EACH SPLICE TRAY THE FOLLOWING:
REFERENCE SECTION 1731 "FIBER OPTIC SPLICE ENCLOSURE"

- 1) SPLICE LOCATION
- 2) DATE
- 3) COMPANY NAME
- 4) NAME OF INDIVIDUAL PERFORMING THE SPLICING

PRIOR TO INSTALLING THE COVER ON THE SPLICE TRAY TAKE A DIGITAL PHOTOGRAPH SHOWING THE SPLICE TRAY AND INFORMATION SHOWN ABOVE (1-4) AND SUBMIT PHOTOGRAPH ALONG WITH OTDR TEST RESULTS.

- NOTES:
1. NOTIFY THE CITY OF CONCORD TRAFFIC ENGINEER, ANDREI DUMITRU, AT (704) 920-5377 FIVE (5) DAYS PRIOR TO BEGINNING WORK ON SIGNAL SYSTEM COMMUNICATIONS CABLE. NOTIFY THE CONCORD TRANSPORTATION DIRECTOR AFTER ALL WORK IS PERFORMED TO ENSURE THAT ALL FIBER CIRCUITS ARE FUNCTIONING PROPERLY. ALL WORK IS NOT COMPLETE UNTIL THE SIGNAL SYSTEM IS BACK UP AND OPERATIONAL.
 2. TRANSCEIVER TERMINATION CONFIGURATIONS ARE GENERIC. THE CITY OF CONCORD IS RESPONSIBLE FOR DETERMINING /ENSURING PROPER TERMINATIONS AND SHALL PERFORM ALL SPLICING AND TERMINATIONS IN CONTROLLER CABINET.
 3. CONTRACTOR TO RECORD EXISTING SPLICE ARRANGEMENT FOR COMPARISON TO THE SUPPLIED SPLICE PLANS. IF DISCREPANCIES EXIST, CONTACT THE ENGINEER TO DETERMINE HOW TO PROCEED WITH RESPLICING. PROVIDE AS-BUILT PLANS TO THE ENGINEER IF FINAL SPLICE ARRANGMENT DIFFERS FROM THE SUPPLIED SPLICE PLANS.

DOCUMENT NOT CONSIDERED FINAL
UNLESS ALL SIGNATURES COMPLETED



Prepared in the Offices of:		<div style="text-align: center;"> </div>	
<div style="text-align: center;"> </div>			
<div style="text-align: center;"> </div>		<div style="text-align: center;"> </div>	

Division 10 Cabarrus County Concord

PLAN DATE: June 2016 REVIEWED BY: C.L. Kalencik

PREPARED BY: S.W. Cox REVIEWED BY:

REVISIONS	INIT.	DATE

DocuSigned by: Steven Cox 7/7/2016

CADD Filename: