

NOT TO SCALE



**DOCUMENT NOT CONSIDERED FINAL  
UNLESS ALL SIGNATURES COMPLETED**

PROJECT REFERENCE NO. <b>R-3826</b>	SHEET NO. <b>UC-3C</b>
DESIGNED BY: <b>CDB</b>	
DRAWN BY: <b>JNA</b>	
CHECKED BY: <b>CLS</b>	
APPROVED BY: <b>CLS</b>	
REVISED:	
NORTH CAROLINA DEPARTMENT OF TRANSPORTATION UTILITIES ENGINEERING SEC. PHONE: (919) 707-6690 FAX: (919) 250-4151	
UTILITY CONSTRUCTION PLANS ONLY	

# OWNER'S TYPICAL DETAILS

## UTILITY CONSTRUCTION

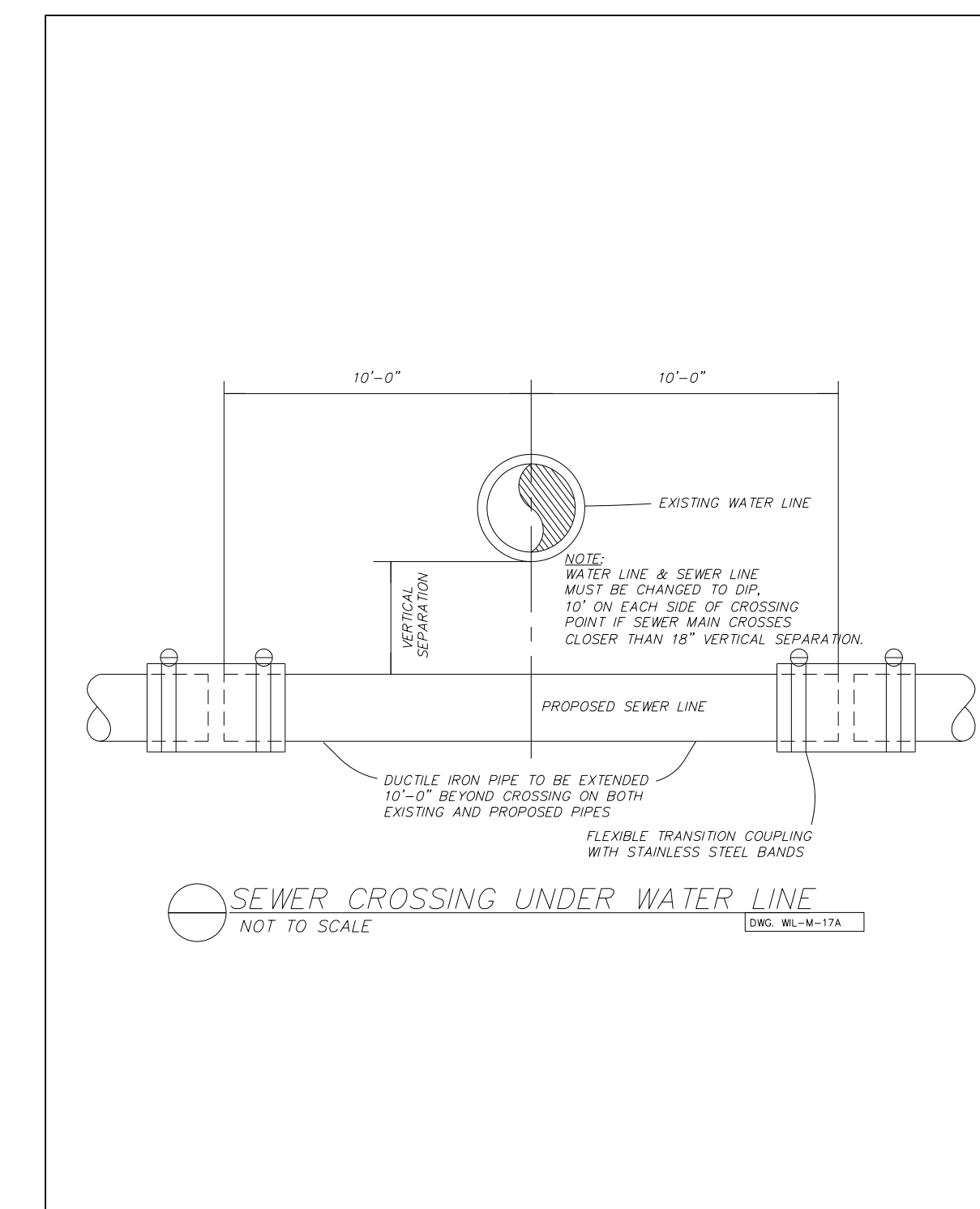
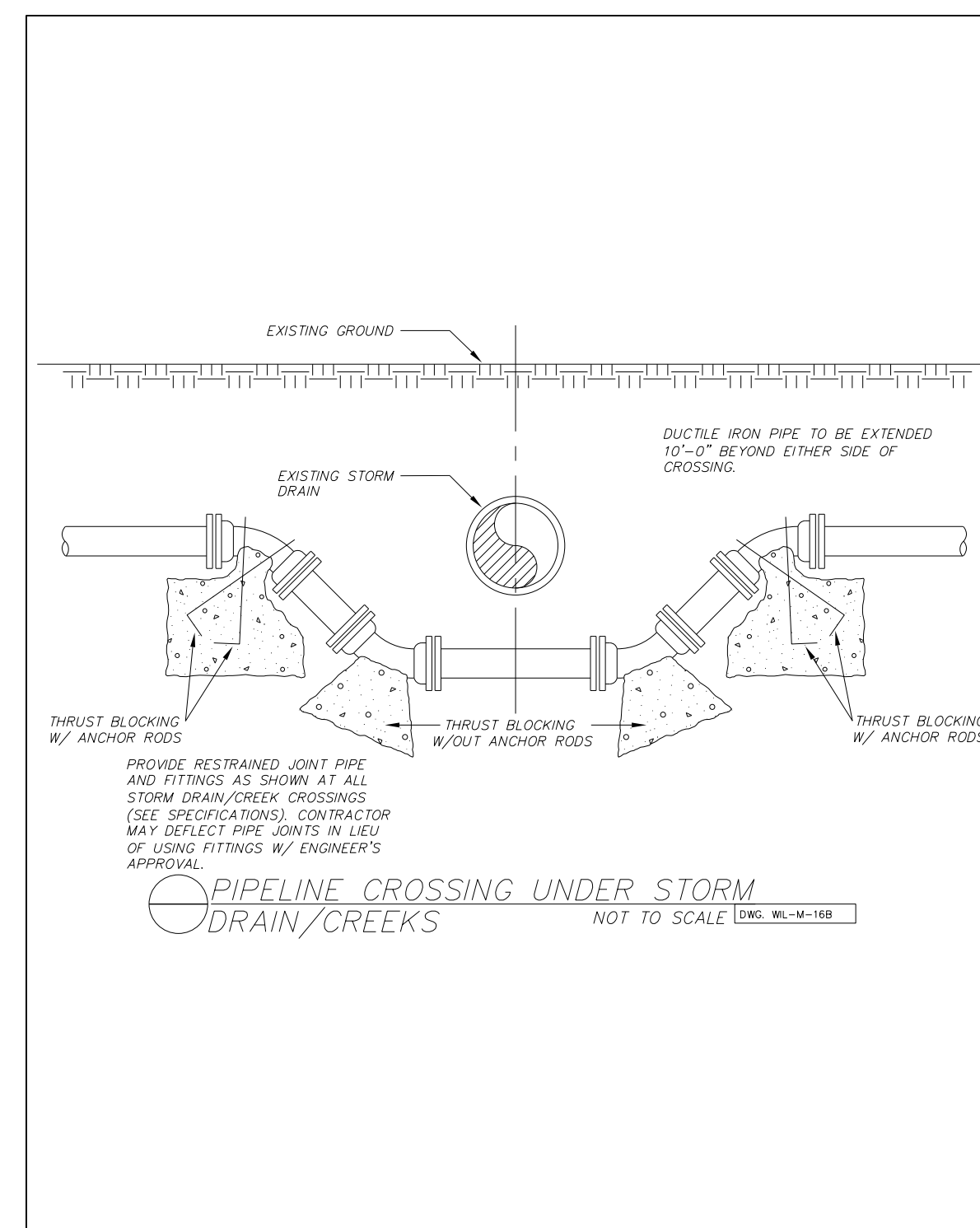
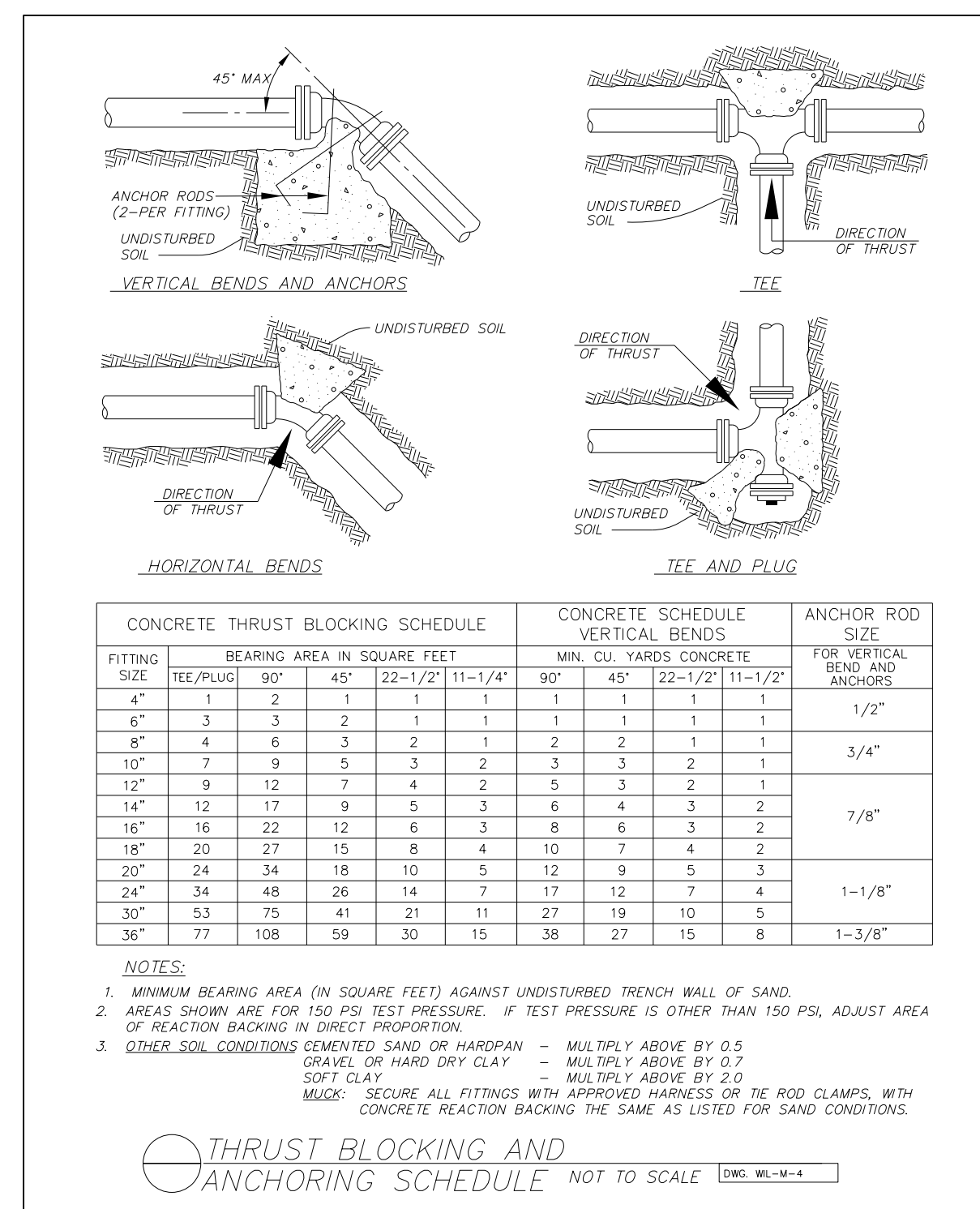
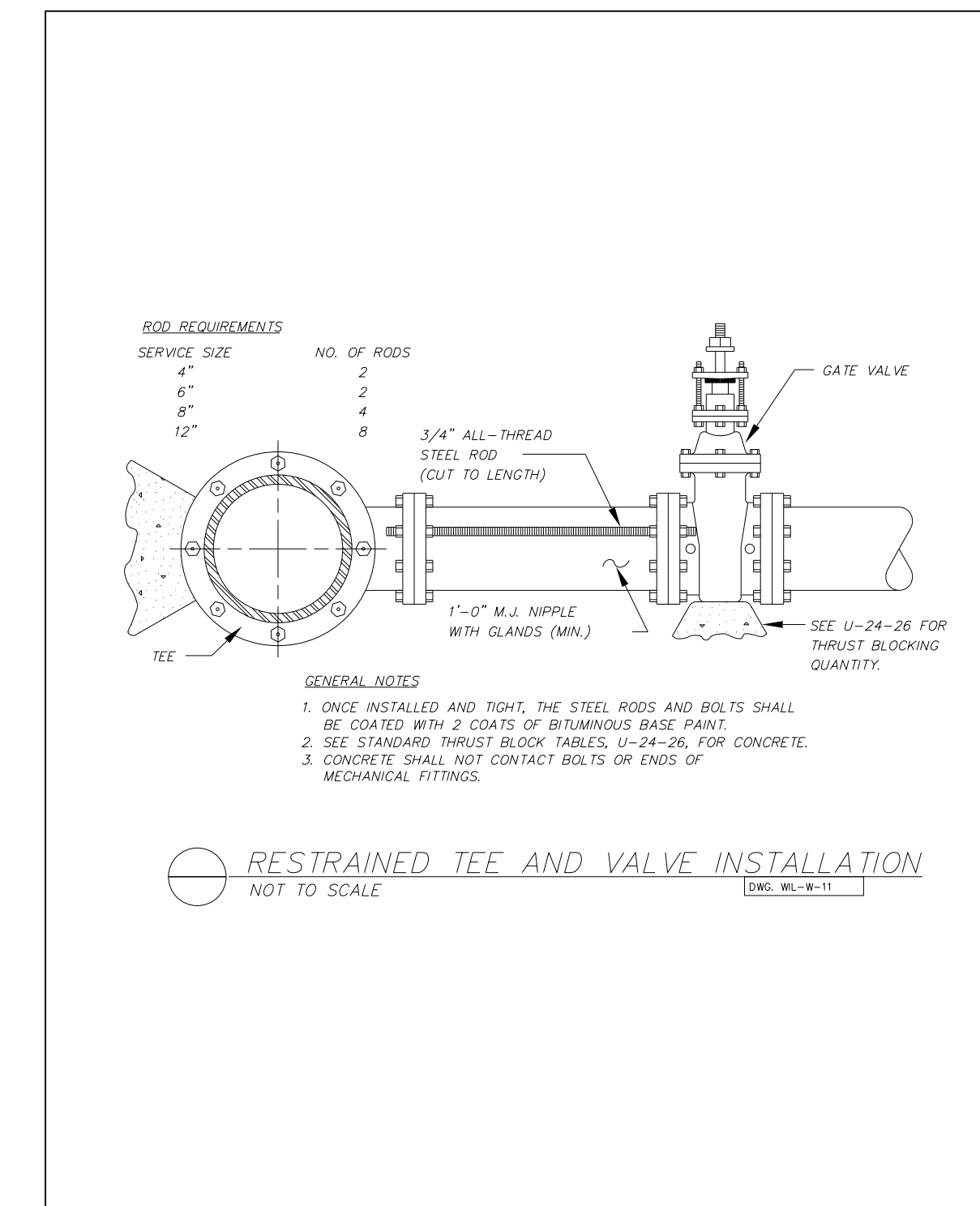
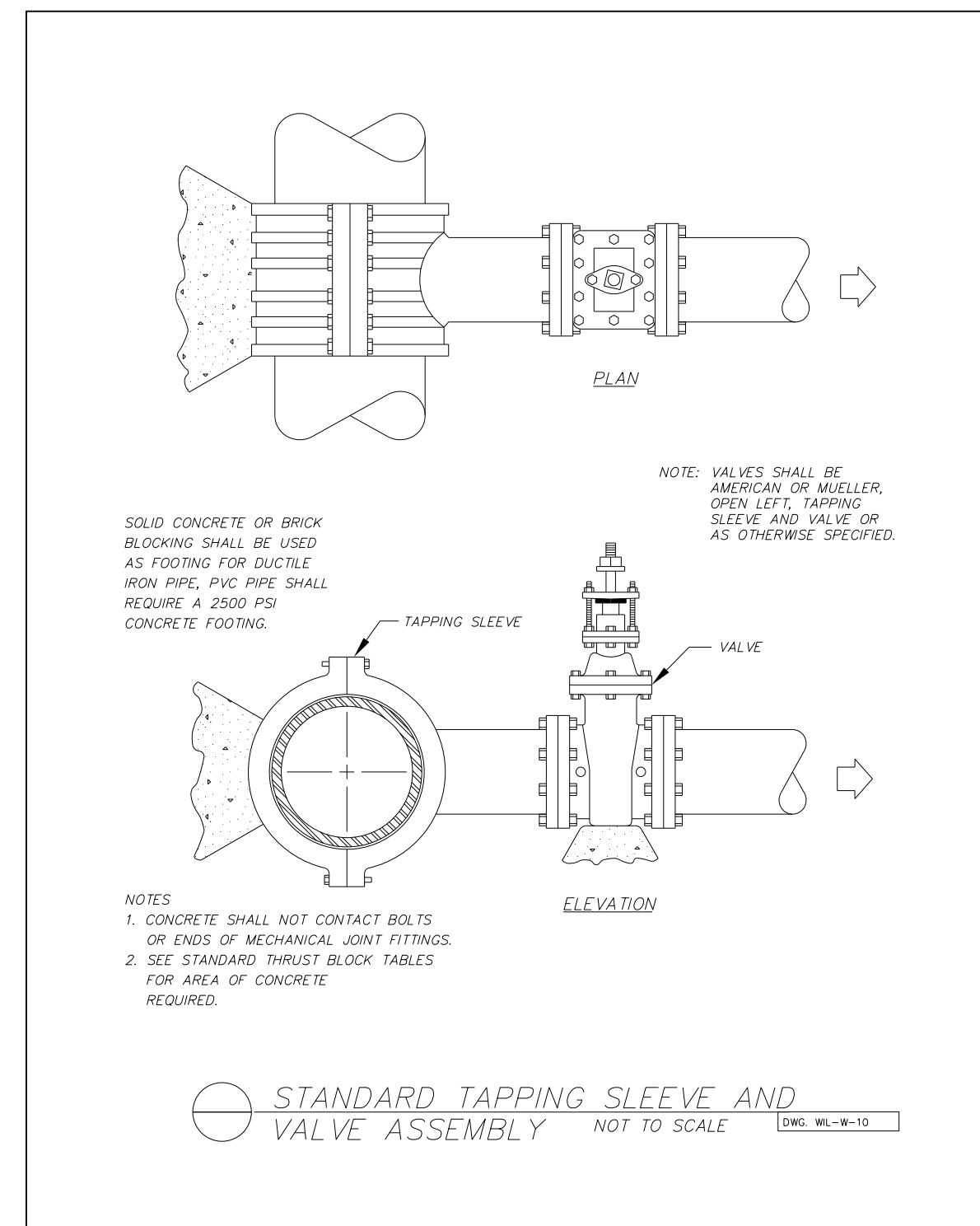
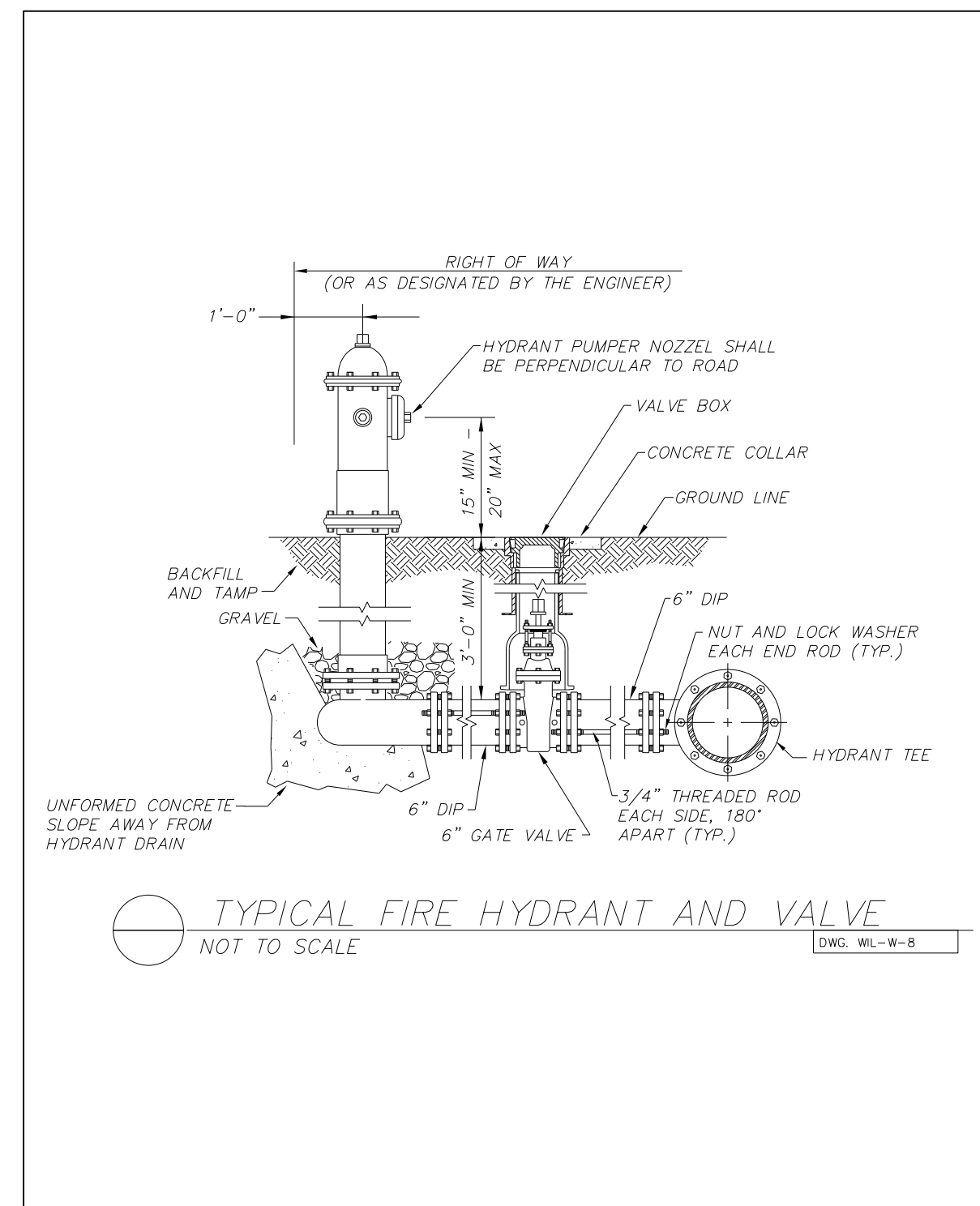

2: NOV-2016 08:56 PROJECTS\2016\A2016400\00\_NCDOT\_R-3826\Design\Utilities\Engineering\UC\Proj\R3826\_ut\_dtl\_UC3A\_psh.dgn  
 3: 11/21/16  
 4: 11/21/16  
 5: 11/21/16  
 6: 11/21/16  
 7: 11/21/16  
 8: 11/21/16  
 9: 11/21/16  
 10: 11/21/16  
 11: 11/21/16  
 12: 11/21/16  
 13: 11/21/16  
 14: 11/21/16  
 15: 11/21/16  
 16: 11/21/16  
 17: 11/21/16  
 18: 11/21/16  
 19: 11/21/16  
 20: 11/21/16  
 21: 11/21/16  
 22: 11/21/16  
 23: 11/21/16  
 24: 11/21/16  
 25: 11/21/16  
 26: 11/21/16  
 27: 11/21/16  
 28: 11/21/16  
 29: 11/21/16  
 30: 11/21/16  
 31: 11/21/16  
 32: 11/21/16  
 33: 11/21/16  
 34: 11/21/16  
 35: 11/21/16  
 36: 11/21/16  
 37: 11/21/16  
 38: 11/21/16  
 39: 11/21/16  
 40: 11/21/16  
 41: 11/21/16  
 42: 11/21/16  
 43: 11/21/16  
 44: 11/21/16  
 45: 11/21/16  
 46: 11/21/16  
 47: 11/21/16  
 48: 11/21/16  
 49: 11/21/16  
 50: 11/21/16  
 51: 11/21/16  
 52: 11/21/16  
 53: 11/21/16  
 54: 11/21/16  
 55: 11/21/16  
 56: 11/21/16  
 57: 11/21/16  
 58: 11/21/16  
 59: 11/21/16  
 60: 11/21/16  
 61: 11/21/16  
 62: 11/21/16  
 63: 11/21/16  
 64: 11/21/16  
 65: 11/21/16  
 66: 11/21/16  
 67: 11/21/16  
 68: 11/21/16  
 69: 11/21/16  
 70: 11/21/16  
 71: 11/21/16  
 72: 11/21/16  
 73: 11/21/16  
 74: 11/21/16  
 75: 11/21/16  
 76: 11/21/16  
 77: 11/21/16  
 78: 11/21/16  
 79: 11/21/16  
 80: 11/21/16  
 81: 11/21/16  
 82: 11/21/16  
 83: 11/21/16  
 84: 11/21/16  
 85: 11/21/16  
 86: 11/21/16  
 87: 11/21/16  
 88: 11/21/16  
 89: 11/21/16  
 90: 11/21/16  
 91: 11/21/16  
 92: 11/21/16  
 93: 11/21/16  
 94: 11/21/16  
 95: 11/21/16  
 96: 11/21/16  
 97: 11/21/16  
 98: 11/21/16  
 99: 11/21/16  
 100: 11/21/16