

STATE	PROJECT NO.	SHEET NO.	TOTAL SHEETS
N.C.	2017CPT.I0.I6.I0041.I - ETC. 2017CPT.I0.I6.20041.4 - ETC. 2017CPT.I0.I6.20042.8 - ETC.	11	
F.A. PROJECT NO.			

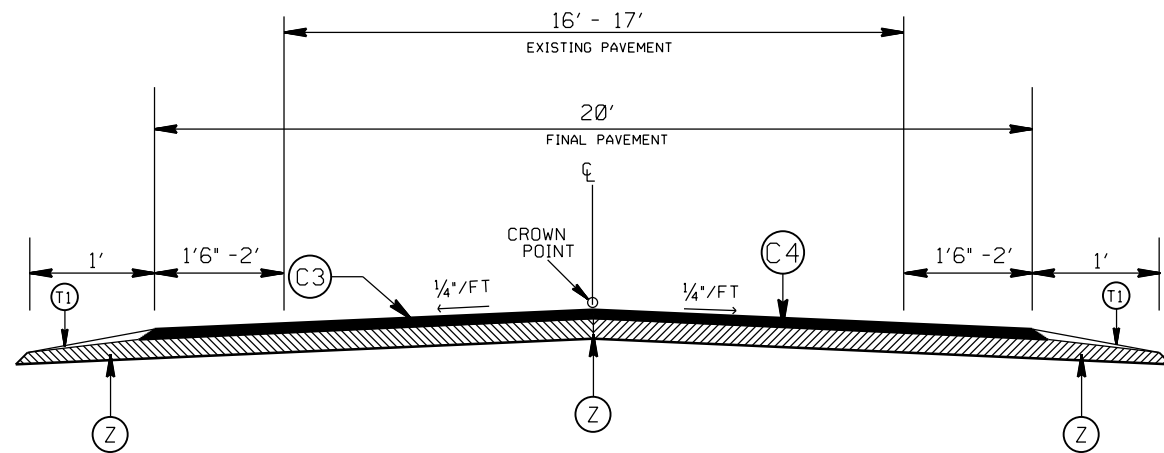

TYPICAL SECTION NO. 7

SR 1252 LOWER WHITE STORE ROAD (MAP 5)
SR 1235 HORNE STORE ROAD (MAP 10)
* SEE NOTES 2, 4 AND 5

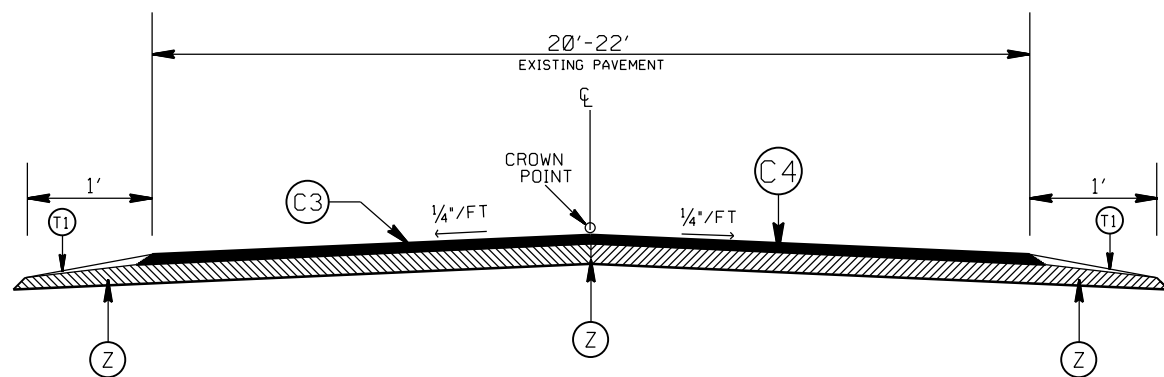

TYPICAL SECTION NO. 8

SR 1238 HASTY ROAD (MAP 9)
*SEE NOTE 4

PAVEMENT SCHEDULE

(C1)	PROP. APPROX. 2.0" ASPHALT CONC. SURFACE COURSE, TYPE S9.5C, AT AN AVERAGE RATE OF 224 LBS. PER SQ. YD.
(C2)	PROP. APPROX. 1.5" ASPHALT CONC. SURFACE COURSE, TYPE S9.5B, AT AN AVERAGE RATE OF 168 LBS. PER SQ. YD.
(C3)	PROP. APPROX. 1.0" ASPHALT CONC. SURFACE COURSE, TYPE SF9.5A, AT AN AVERAGE RATE OF 110 LBS. PER SQ. YD.
(C4)	PROP. ASPHALT SURFACE TREATMENT, TYPE 78M, DOUBLE SEAL.
(D1)	PROPOSED 2.5" ASPHALT CONC. INTERMEDIATE CORSE, TYPE I19.0B, AT AN AVERAGE RATE OF 285 LBS. PER SQ. YD.
(D2)	AST MAT COAT # 67
(T1)	SHOULDER RECONSTRUCTION
(V1)	MILLING OF EXISTING PAVEMENT, 2.0" IN DEPTH.
(V2)	MILLING OF EXISTING PAVEMENT, 3.5" IN DEPTH.
(V3)	PROFILE MILLING EXISTING ASPHALT, 0 - 2"
(U)	EXISTING PAVEMENT
(Z)	FULL DEPTH RECLAMATION

2017-2018
ANSON COUNTY RESURFACING

SCALE	-NA-		REVISIONS
DATE	10/16		
DWG. BY	AMO		
DESIGN BY	AMO		
APPROVED	CLA		