

**This electronic collection of documents is provided
for the convenience of the user
and is Not a Certified Document –**

**The documents contained herein were originally issued
and sealed by the individuals whose names and license
numbers appear on each page, on the dates appearing
with their signature on that page.**

**This file or an individual page
shall not be considered a certified document.**

09/08/99

See Sheet 1-A For Index of Sheets
See Sheet 1-B For Conventional Symbols

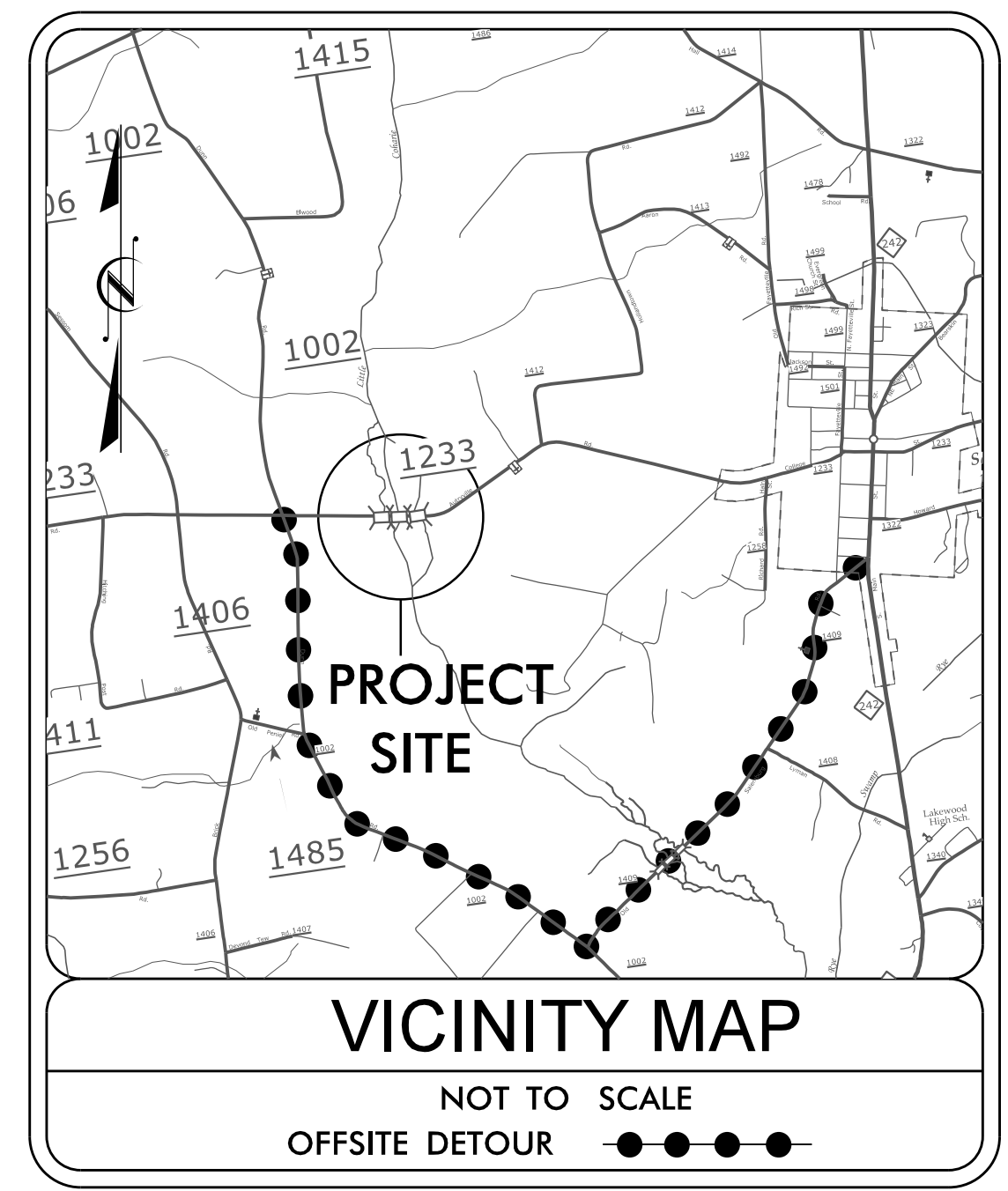

STATE OF NORTH CAROLINA
DIVISION OF HIGHWAYS

**UTILITIES BY OTHERS PLANS
SAMPSON COUNTY**

**LOCATION: BRIDGES NO. 102, 103, AND 104
OVER LITTLE COHARIE CREEK ON SR 1233**

TYPE OF WORK: UTILITIES RELOCATION

T.I.P. NO.	SHEET NO.
B-4814	UO-1

WETHERILL ENGINEERING
1223 Jones Franklin Road
Raleigh, N.C. 27606
License No. F-0377
Bus: 919 851 8077
Fax: 919 851 8107

TRANSPORTATION PLANNING/DESIGN - BRIDGE/STRUCTURE DESIGN
CIVIL/SITE DESIGN - GIS/GPS - CONSTRUCTION OBSERVATION



TIP PROJECT: B-4814

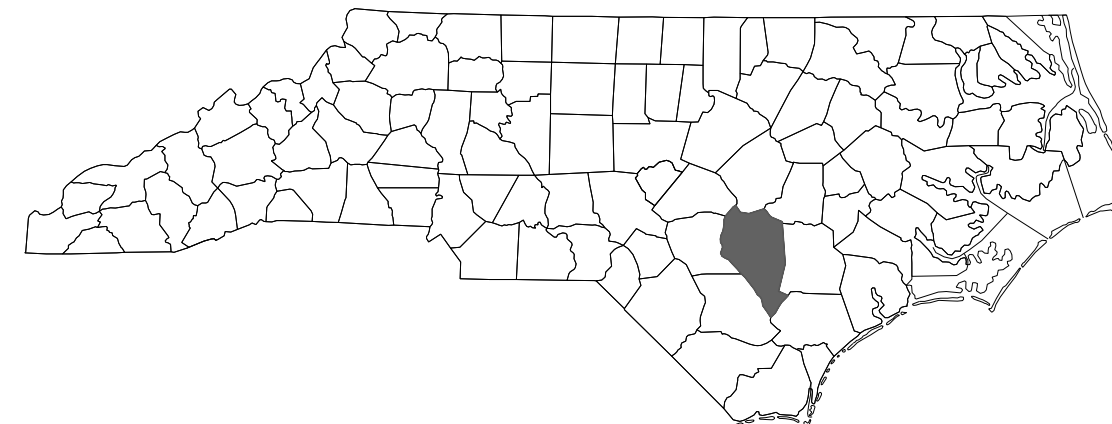

UO-2 4

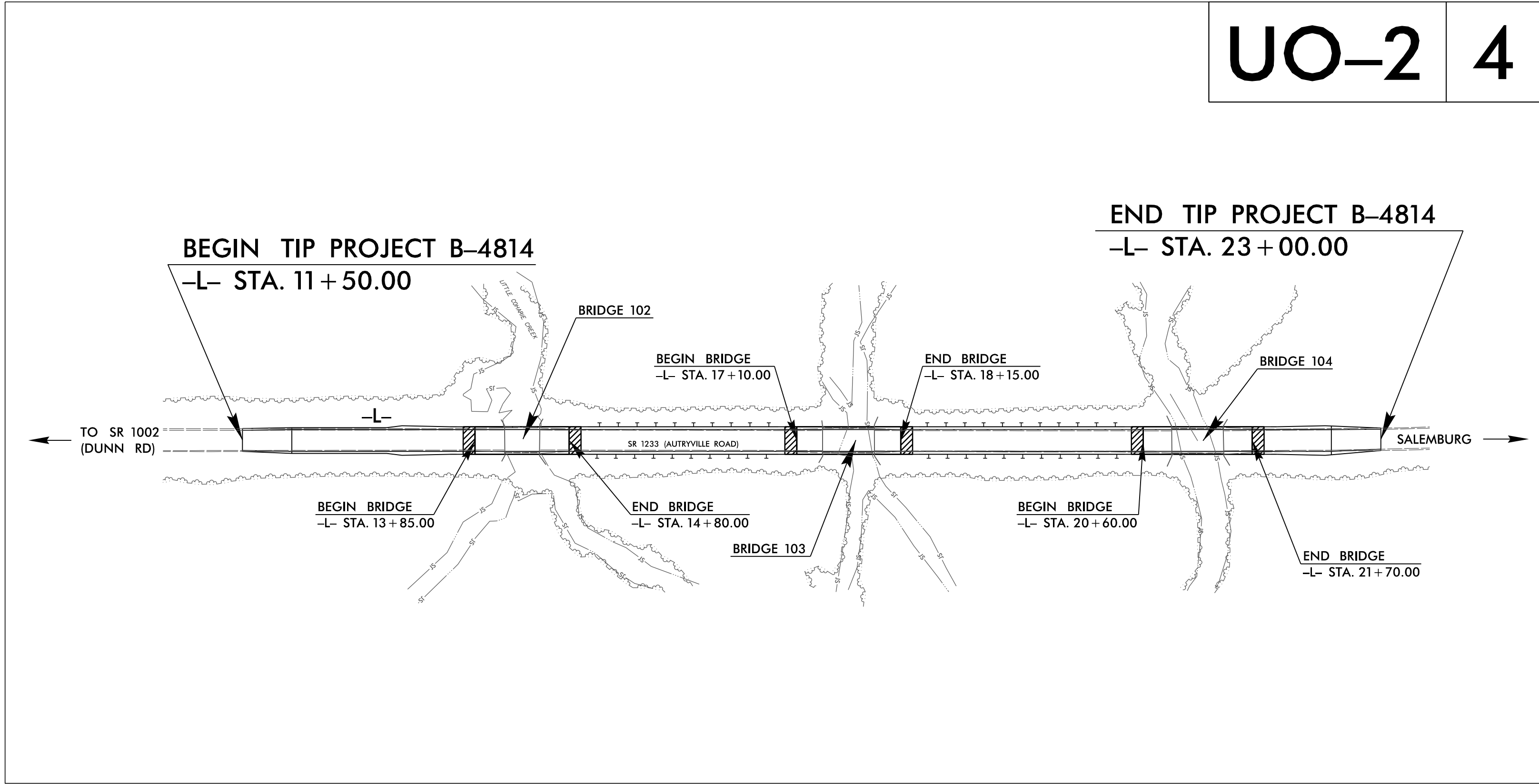

CLEARING ON THIS PROJECT SHOULD BE PERFORMED TO THE LIMITS ESTABLISHED BY METHOD III

CONTRACT:

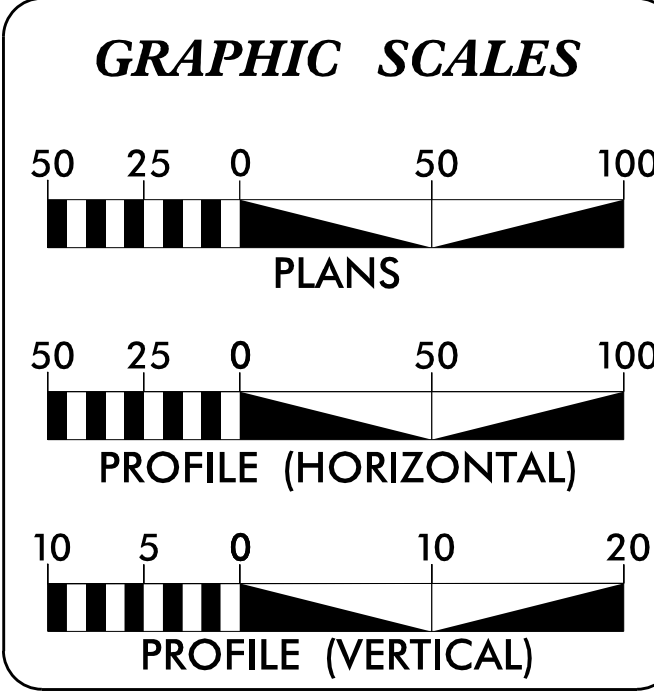

INDEX OF SHEETS

SHEET NO.	DESCRIPTION
UO-1	TITLE SHEET
UO-2	UTILITIES BY OTHERS PLAN SHEET

UTILITY OWNERS ON PROJECT

(A) CENTURYLINK (TELEPHONE)

PREPARED IN THE OFFICE OF:
**DIVISION OF HIGHWAYS
UTILITIES UNIT
UTILITIES ENGINEERING**

1555 MAIL SERVICES CENTER
RALEIGH, NC 27699-1555
PHONE (919) 707-6690
FAX (919) 250-4151

Roger Worthington, P.E. UTILITIES SECTION ENGINEER
Steve McKee, P.E. UTILITIES SQUAD LEADER PROJECT ENGINEER
Jamshid Hafshejani UTILITIES PROJECT DESIGNER

\$\$\$ SYSTEMS \$\$\$
\$\$\$ DGN \$\$\$
\$\$\$ USERNAME \$\$\$

UTILITIES BY OTHERS

NOTE:
 ALL PROPOSED UTILITY WORK SHOWN ON THIS SHEET WILL BE DONE BY OTHERS. NO PAYMENT WILL BE MADE TO THE CONTRACTOR FOR PROPOSED UTILITY WORK SHOWN ON THIS SHEET.



END TIP PROJECT B-4814
-L- STA. 23 + 00.00

BEGIN TIP PROJECT B-4814
-L- STA. 11 + 50.00

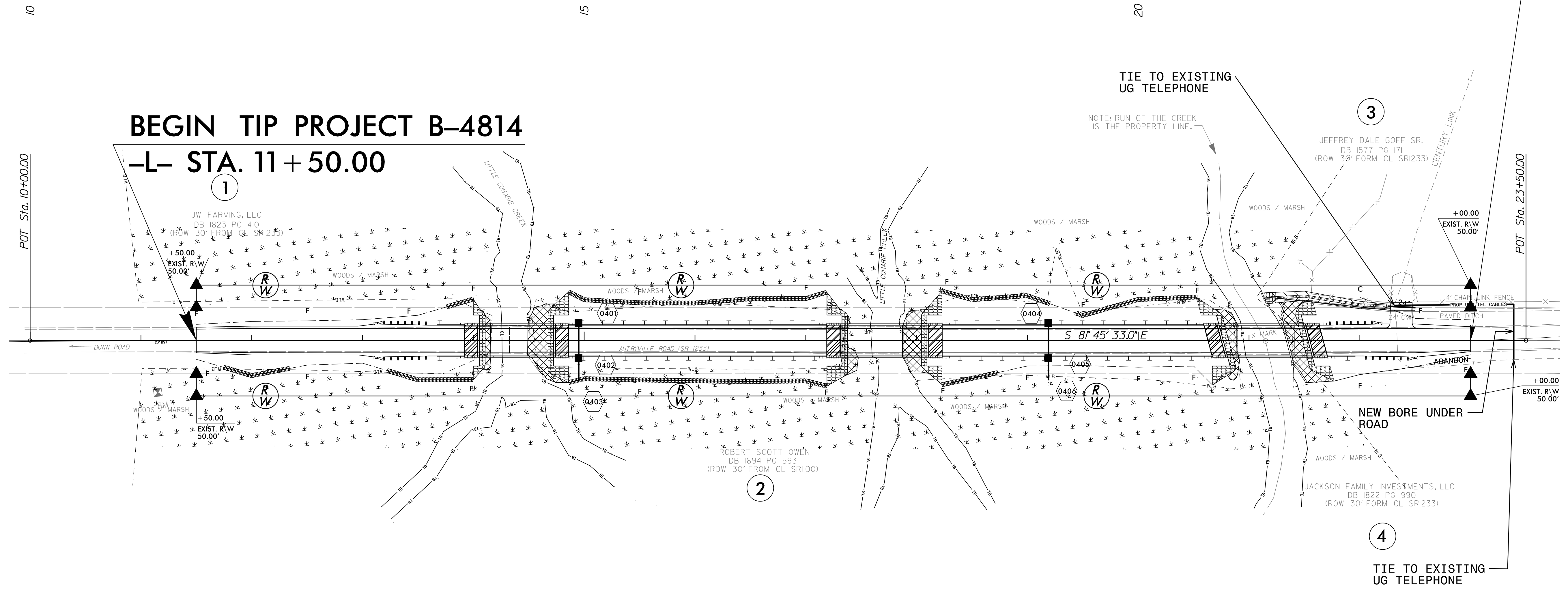

REVISIONS

8/17/99
 2/22/05, P.V.
 10/20/14, B-4814 Utilities\Redy_Ut\Proj\B4814_11-23.dwg
 10/20/15