

TIP NO.	SHEET NO.	TOTAL SHEETS
I-5833	7	

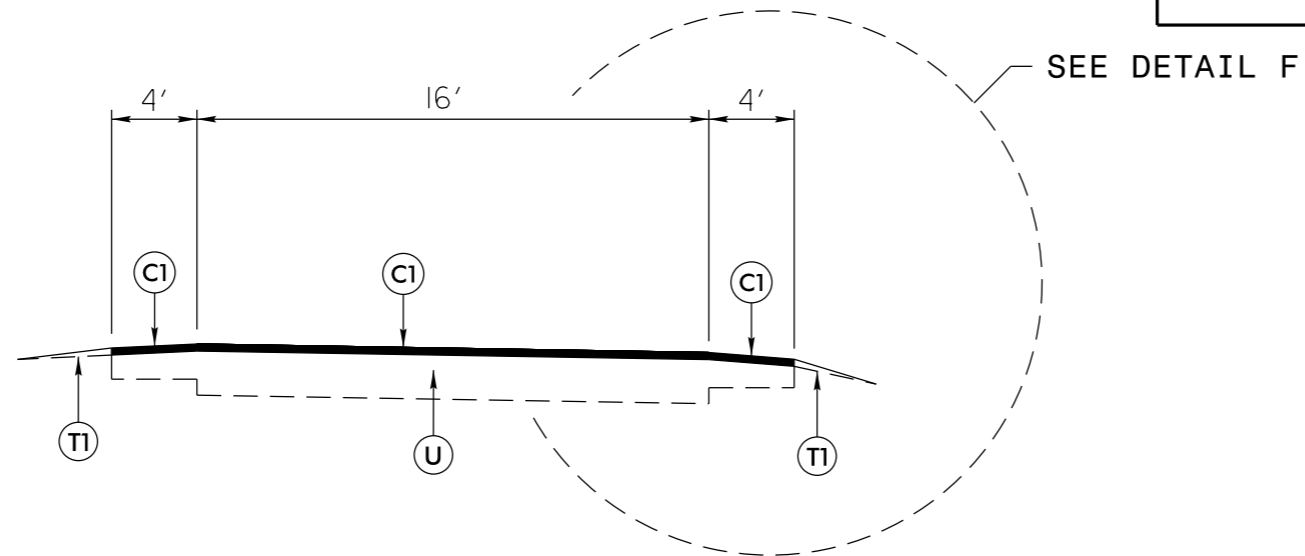

TYPICAL SECTION NO. 9

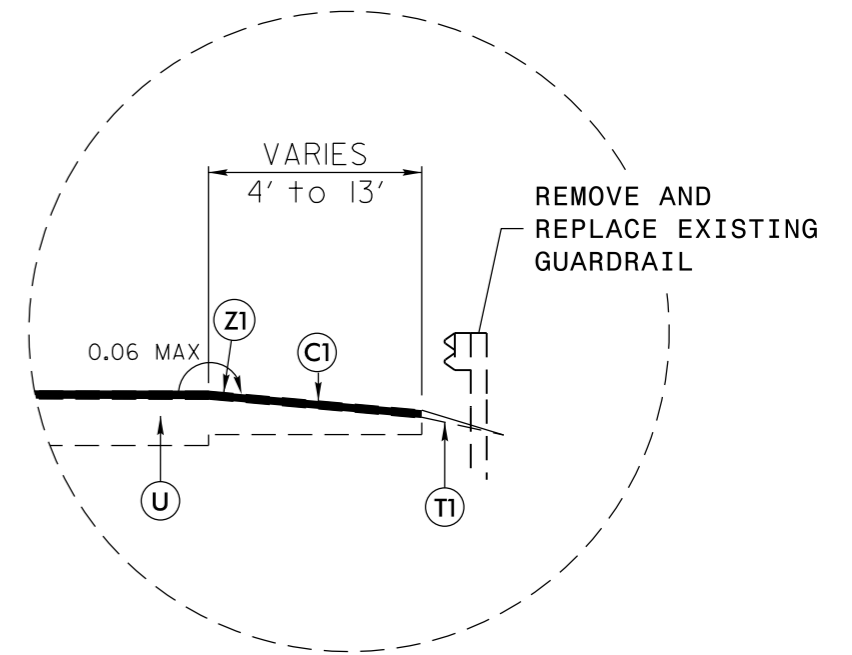

**DETAIL F
VARIOUS LOCATIONS**

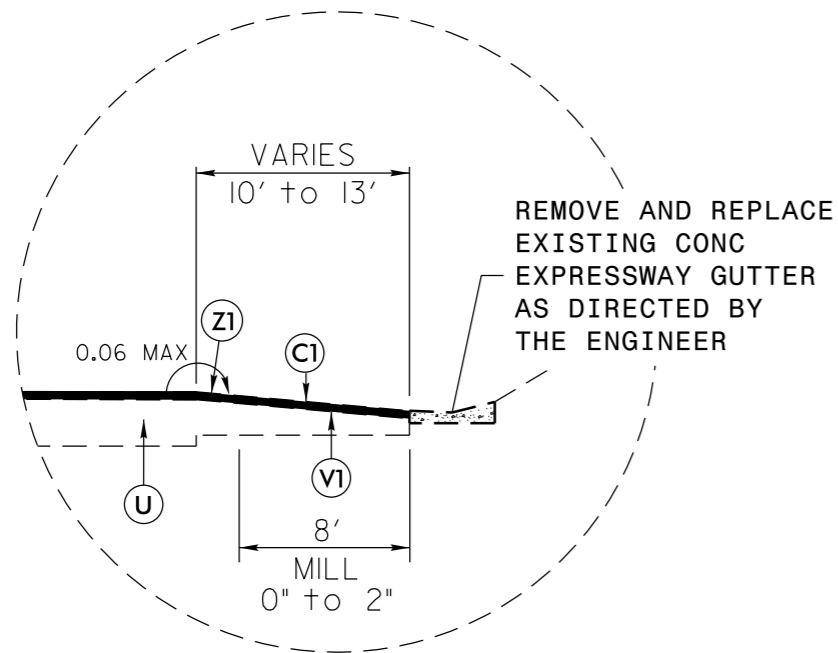

**DETAIL D
VARIOUS LOCATIONS**

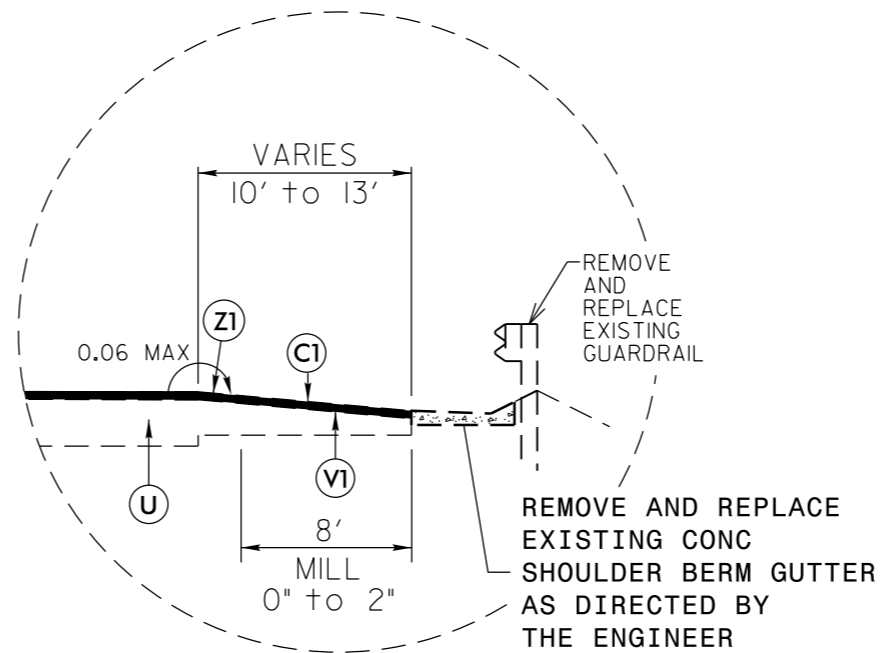

**DETAIL E
VARIOUS LOCATIONS**

PAVEMENT SCHEDULE	
C1	PROP. APPROX. 2" ASPHALT CONCRETE SURFACE COURSE, TYPE S9.5D, AT AN AVERAGE RATE OF 224 LBS. PER SQ. YD.
T1	SHOULDER RECONSTRUCTION
U	EXISTING PAVEMENT
V1	MILLING ASPHALT PAVEMENT, 0" - 2" DEPTH
Z1	MILLED RUMBLE STRIPS (ASPHALT CONCRETE)