

NOTES

CONTRACTOR SHALL REMOVE SURFACE CONCRETE TO VERIFY THAT SAWCUT DEPTH WILL NOT DAMAGE EXISTING REINFORCING STEEL OR PRESTRESSED TENDONS.

CONTRACTOR SHALL SAW CUT TO A NOMINAL DEPTH OF 1/2" BUT REINFORCING STEEL AND PRESTRESSED TENDONS SHALL NOT BE DAMAGED.

CONTRACTOR SHALL SAW CUT THE REPAIR AREAS SO THAT THE CORNERS ARE SQUARE AS INDICATED ON THE DETAILS.

CONCRETE REPAIRS MAY BE SUBSTITUTED IN LIEU OF SHOTCRETE REPAIRS WITH THE APPROVAL OF THE ENGINEER.

FOR SHOTCRETE REPAIRS, SEE SPECIAL PROVISIONS.

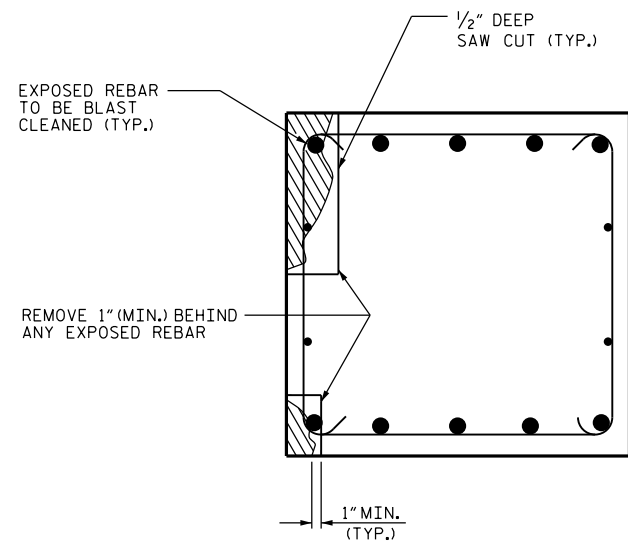

SECTION A-A

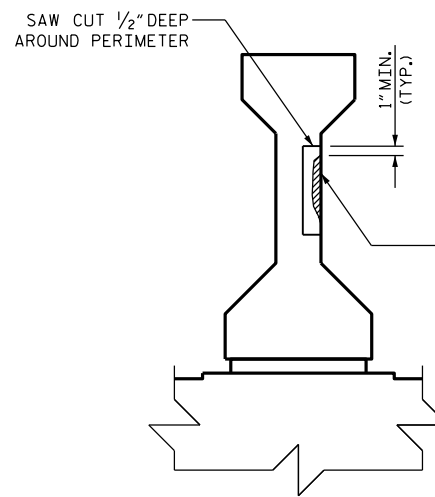

SECTION B-B

(IF MORE THAN HALF THE CIRCUMFERENCE OF REINFORCING BAR IS EXPOSED DURING THIS PROCESS, REMOVE ADDITIONAL CONCRETE BEHIND THE BAR. THIS DOES NOT APPLY TO PRESTRESSED STRANDS.)

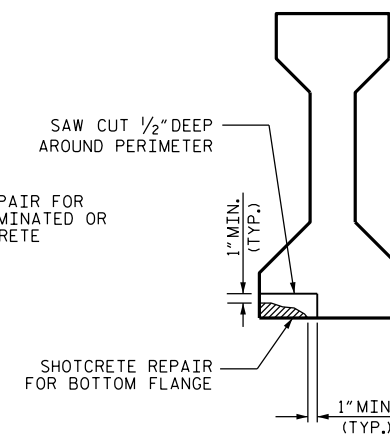

SECTION C-C

(ALL UNSOUND CONCRETE MUST BE REMOVED. HOWEVER, PRESTRESSED STRANDS SHOULD NOT BE DISTURBED UNLESS ABSOLUTELY NECESSARY. USE EXTREME CARE TO NOT DAMAGE STRANDS.)

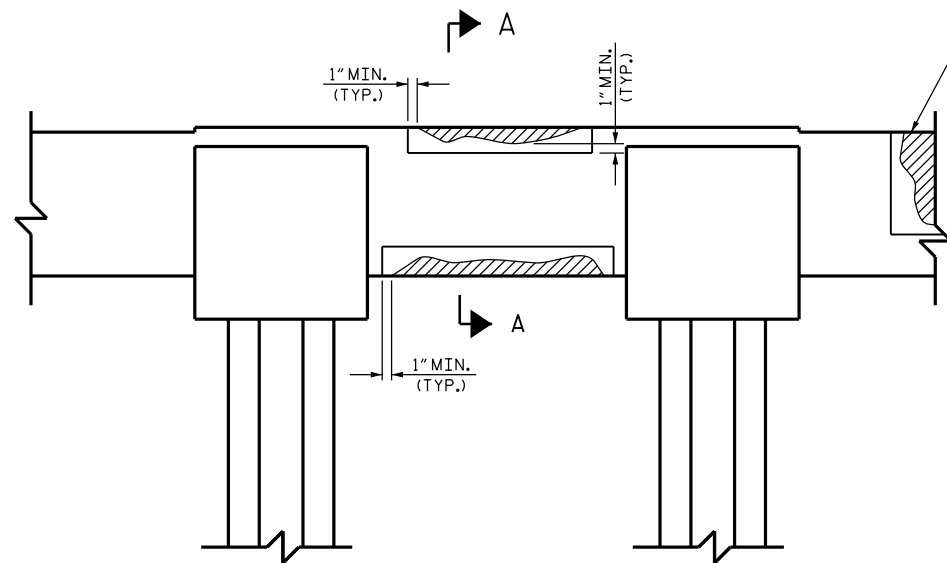

BENT CAP REPAIRS

CAP REPAIR

SPALLED, DELAMINATED OR CRACKED CONCRETE (REMOVE UNTIL SOUND CONCRETE IS FOUND AND 1" MIN. BEHIND ANY EXPOSED REBAR) (TYP.)

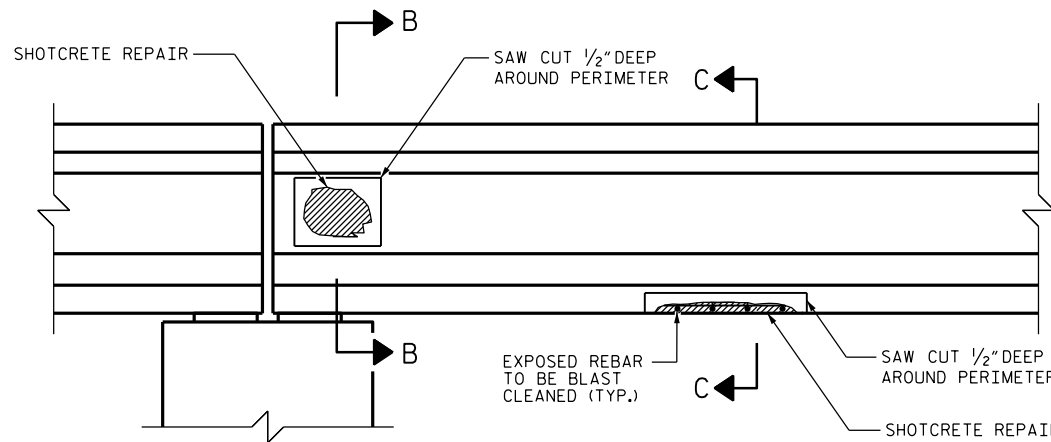

ELEVATION

CONCRETE GIRDER REPAIR DETAIL

PROJECT NO. B-5936
TYRRELL COUNTY
 BRIDGE NO. 7

SHEET 1 OF 2



DocuSigned by:
Robbie Weisz
 CEA153463B6D43D...

8/11/2016

DOCUMENT NOT CONSIDERED
 FINAL UNLESS ALL
 SIGNATURES COMPLETED

STATE OF NORTH CAROLINA DEPARTMENT OF TRANSPORTATION RALEIGH						SHEET NO.
TYPICAL CAP & GIRDER REPAIR DETAILS						S-381
REVISIONS						TOTAL SHEETS
NO.	BY:	DATE:	NO.	BY:	DATE:	394
1			3			
2			4			

DRAWN BY : S. T. SANDOR DATE : 06/2016
 CHECKED BY : R. N. WEISZ DATE : 06/2016

15-JUL-2016 09:17
 R:\Structures\401.037.B5936.SMU.529.Repairs.DGN
 ssandor