

DRAWN BY : K. D. LAYNE DATE : 2/04/16
 CHECKED BY : R. P. PATEL DATE : 2/09/16
 DESIGN ENGINEER OF RECORD : T. R. PETERSON DATE : 6/20/16

ELEVATION

NOTES

STIRRUPS IN CAP MAY BE SHIFTED AS NECESSARY TO CLEAR ANCHOR BOLTS.
 HOOKS ON "V" BARS MAY BE TURNED AS NECESSARY FOR PLACING REINFORCING STEEL.
 ALL STEEL IN THE DRILLED PIERS IS INCLUDED IN THE PAY ITEMS FOR "REINFORCING STEEL" AND "SPIRAL COLUMN REINFORCING STEEL".
 THE CONTRACTOR'S ATTENTION IS CALLED TO THE FACT THAT THE LONGITUDINAL REINFORCEMENT FOR THE DRILLED PIERS IS DETAILED WITH 3 FEET OF EXTRA LENGTH.
 THE LOCATION OF THE CONSTRUCTION JOINT IN THE DRILLED PIER IS BASED ON AN APPROXIMATE GROUND LINE ELEVATION. IF THE CONSTRUCTION JOINT IS ABOVE THE ACTUAL GROUND ELEVATION, THE CONTRACTOR SHALL PLACE THE CONSTRUCTION JOINT 1 FOOT BELOW THE GROUND LINE.

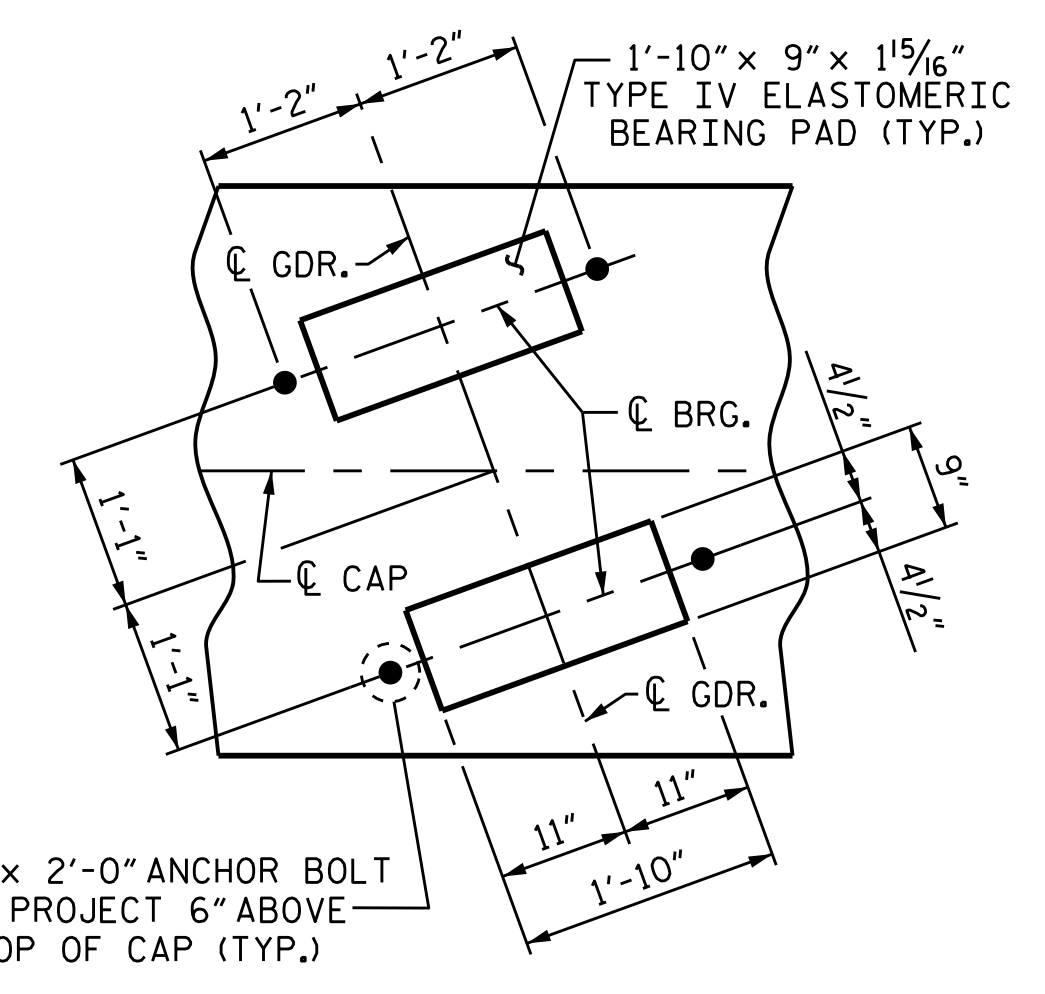

DETAIL "A"
(TYP. EA. BRIDGE SEAT)

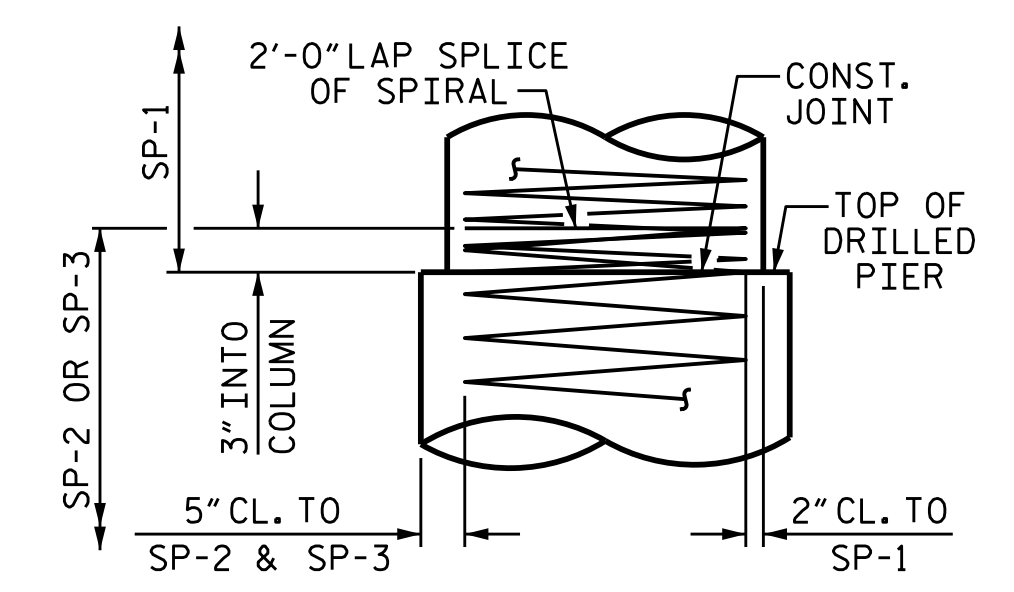

CONSTRUCTION JOINT DETAIL
(TYP. EA. DRILLED PIER)

PROJECT NO. U-3440
CABARRUS COUNTY
 STATION: 68+25.60 -L-

SHEET 1 OF 2

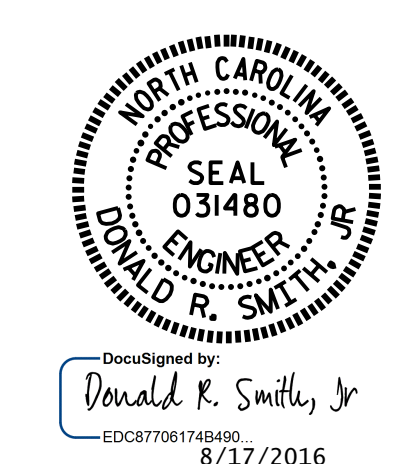

STATE OF NORTH CAROLINA
 DEPARTMENT OF TRANSPORTATION
 RALEIGH
 SUBSTRUCTURE
 BENT #2
 (LEFT LANE)

| REVISIONS | | | | | | SHEET NO. |
|-----------|-----|-------|-----|-----|-------|--------------|
| NO. | BY: | DATE: | NO. | BY: | DATE: | S1-30 |
| 1 | | | 3 | | | TOTAL SHEETS |
| 2 | | | 4 | | | 37 |

STR. #1