

PROJECT REFERENCE NO. <i>R-2915C</i>	SHEET NO. <i>RF-3</i>
RW SHEET NO.	
ROADWAY DESIGN ENGINEER	HYDRAULICS ENGINEER

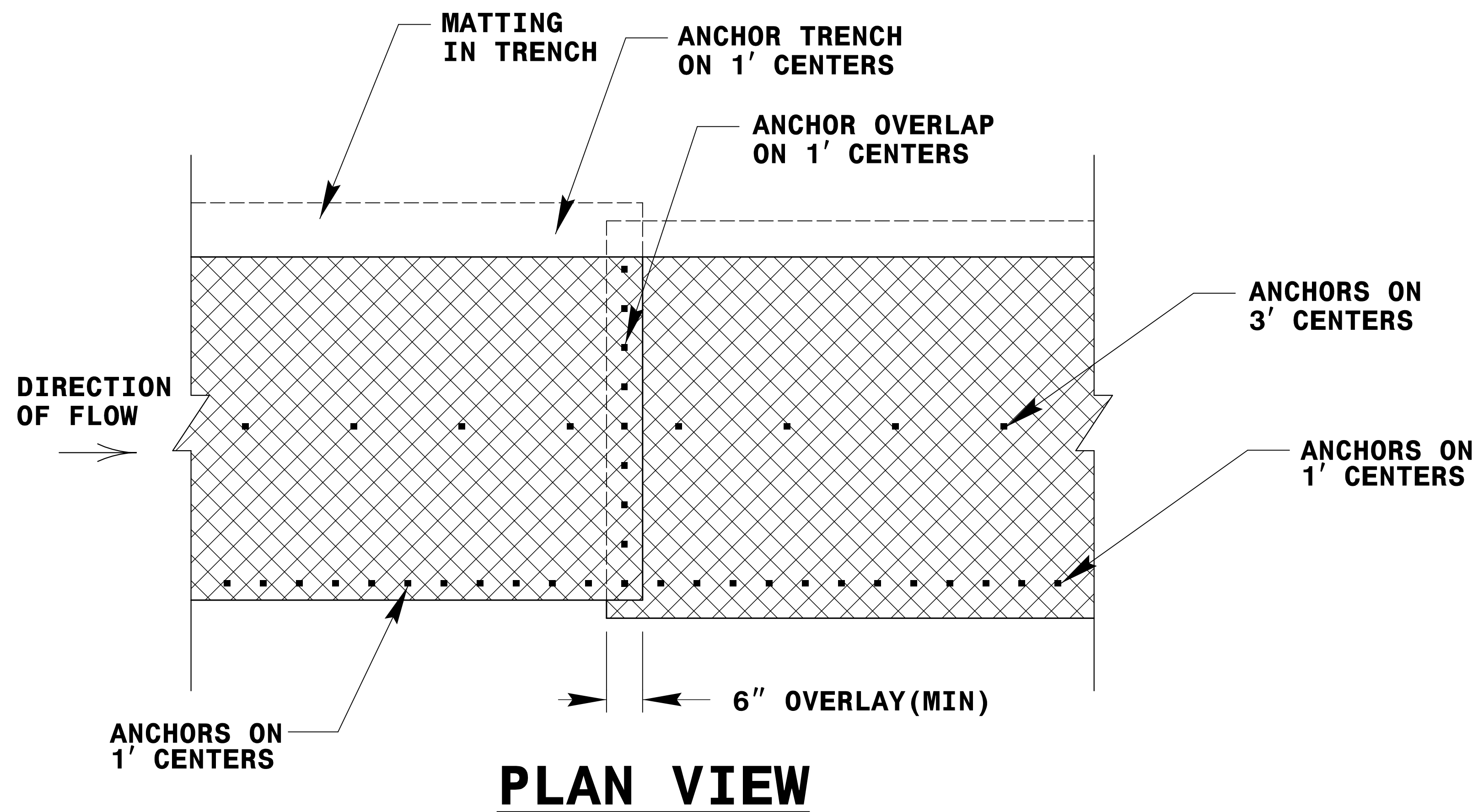

**PLAN VIEW**

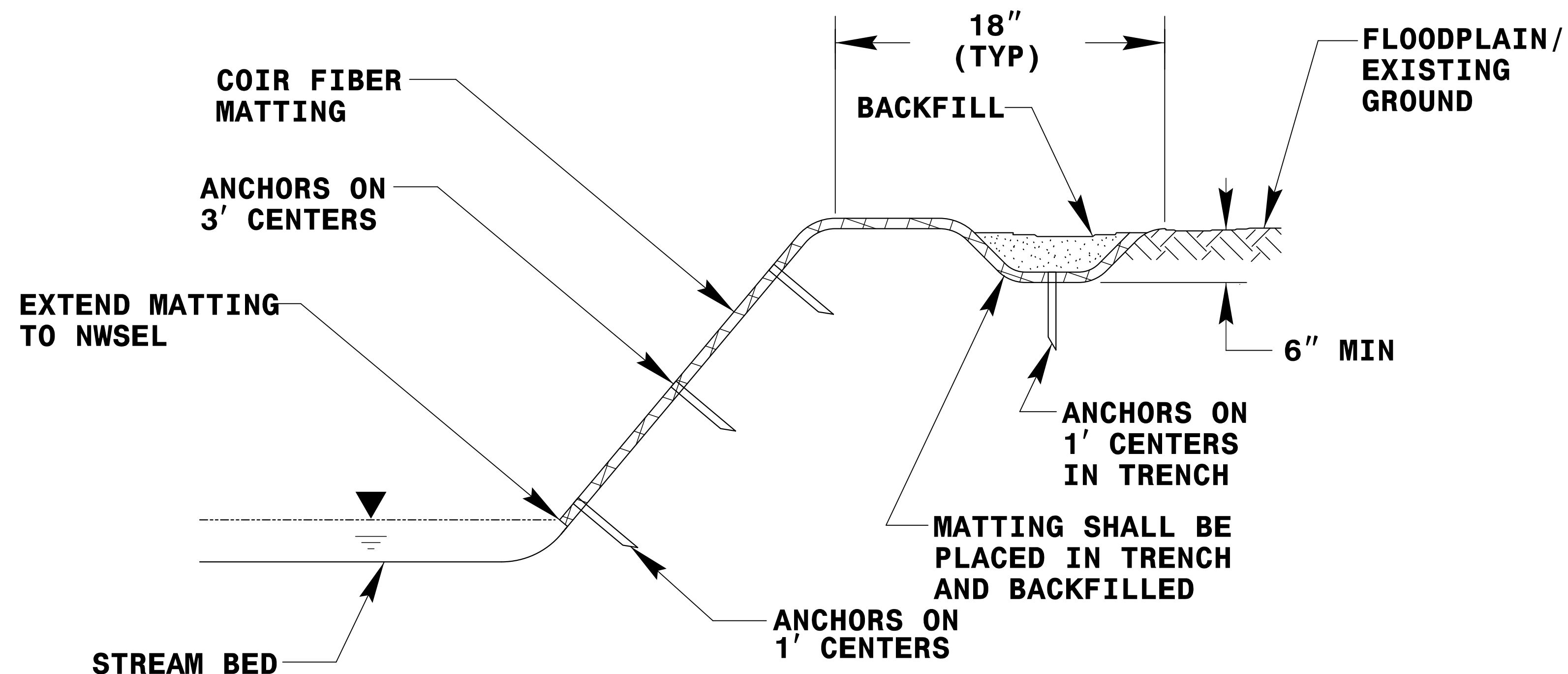

**TYPICAL CROSS SECTION**

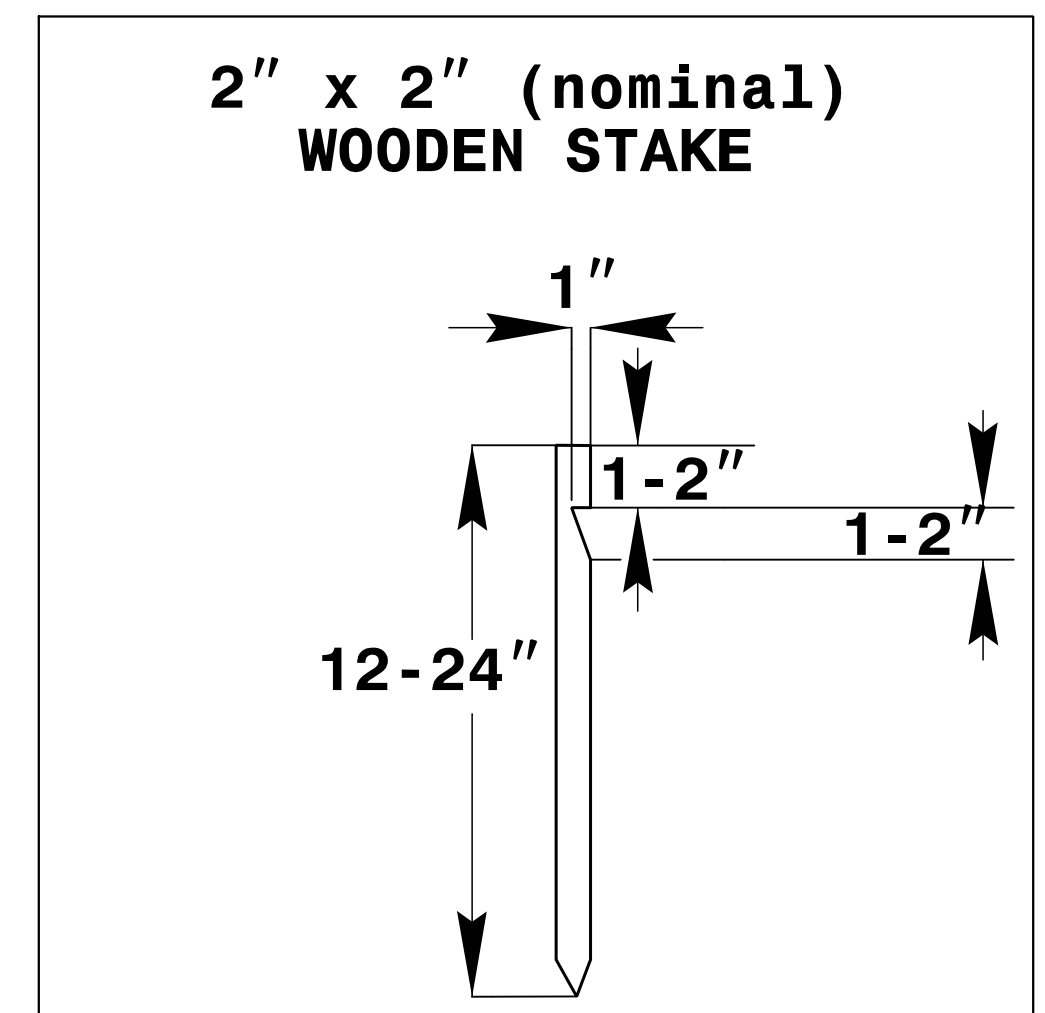

**#10 STEEL REINFORCEMENT BAR**

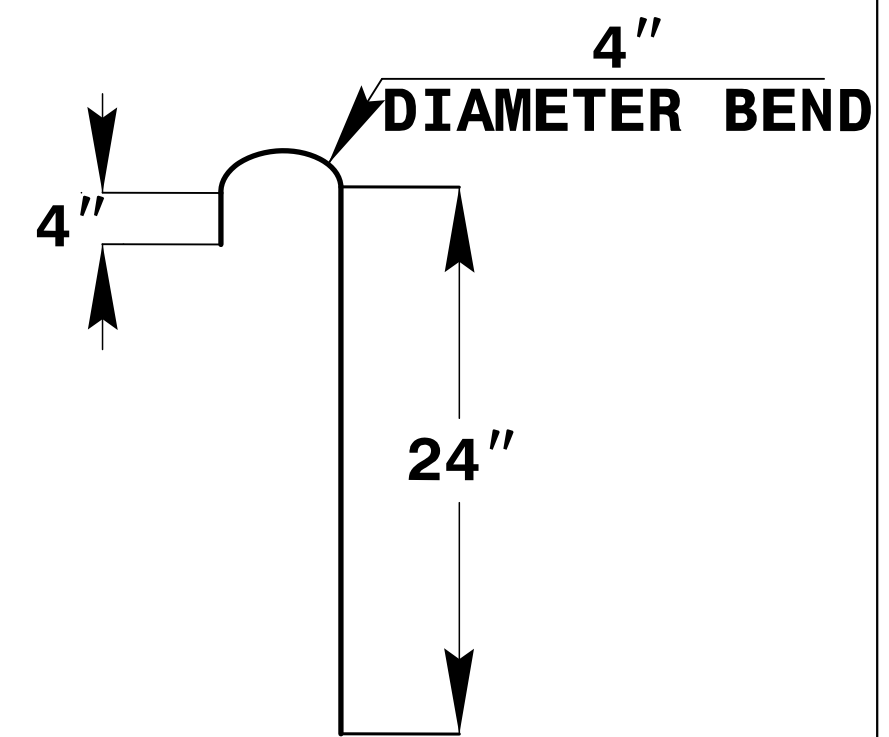

**1\"/>**

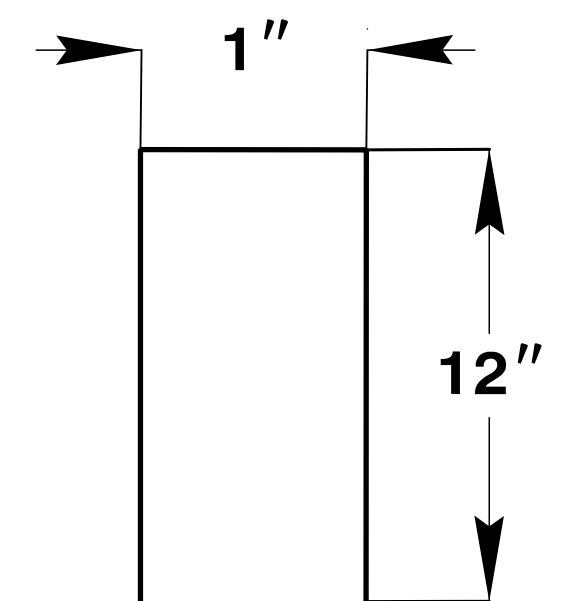

**ANCHOR OPTIONS**

**COIR FIBER MATTING DETAIL**

NOT TO SCALE

**STREAMBANK REFORESTATION**

**DETAIL SHEET 2 OF 2**

N.C.D.O.T.- ROADSIDE ENVIRONMENTAL UNIT