

8/17/99

HNTB HNTB NORTH CAROLINA, P.C.
343 E. Six Forks Road, Suite 200
Raleigh, North Carolina 27609
NC License No: C-1554

PROJECT REFERENCE NO.	SHEET NO.
R-2915C	EC-14/CONST.14
RW SHEET NO.	
ROADWAY DESIGN ENGINEER	HYDRAULICS ENGINEER

MATCH TO SHEET 22
-YII- STA. 12+00.00

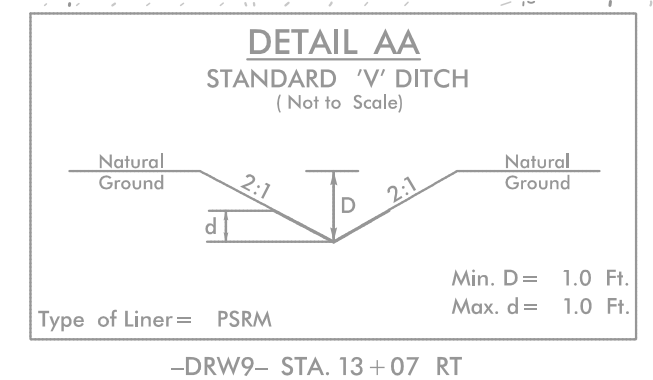

90 x 45 x 3
2 inch Skimmer
with 1.75 inch
Orifice Diameter
15 ft. weir
ID 14.3

100 x 50 x 3
2 inch Skimmer
with 2.0 inch
Orifice Diameter
35 ft. weir
ID 14.1

CLEARING AND GRUBBING
EROSION CONTROL FOR
CONSTRUCTION SHEET 14

MATCH TO SHEET 13 -L- STA. 381+00.00

MATCH TO SHEET 15 -L- STA. 393+00.00

NAD 83
CORS

NOTE:
PLACE TEMPORARY ROCK SEDIMENT DAMS TYPE - B
AND TEMPORARY ROCK SILT CHECKS TYPE - A AT
DRAINAGE OUTLETS.



30 x 70 x 3
1.5 inch Skimmer
with 1.25 inch
Orifice Diameter
10 ft. weir
ID 14.2

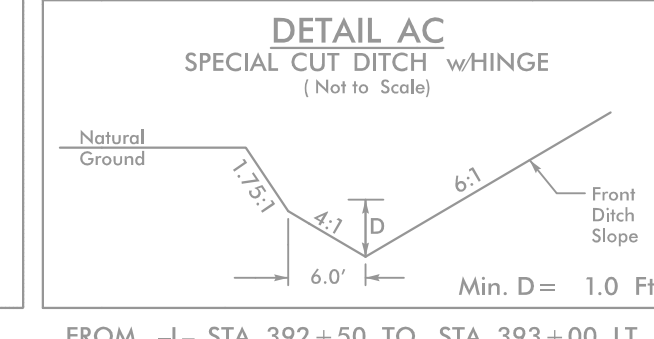
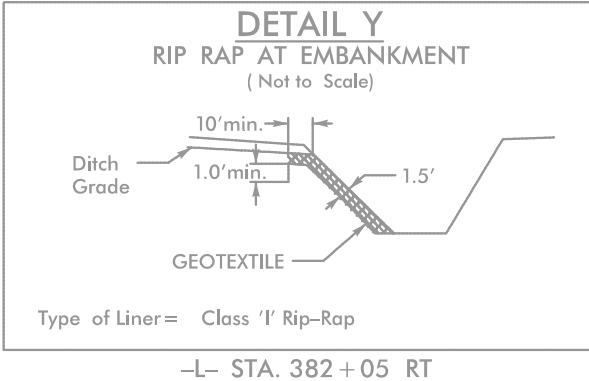
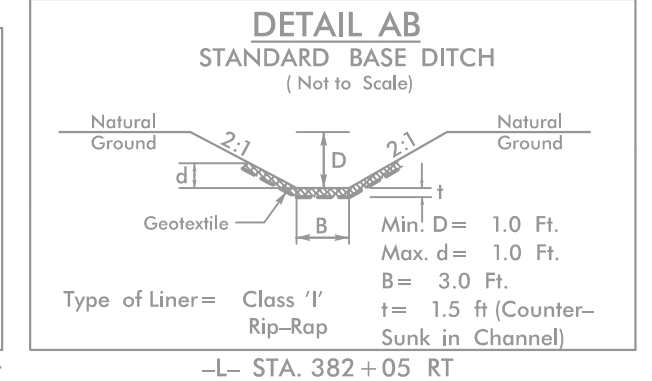
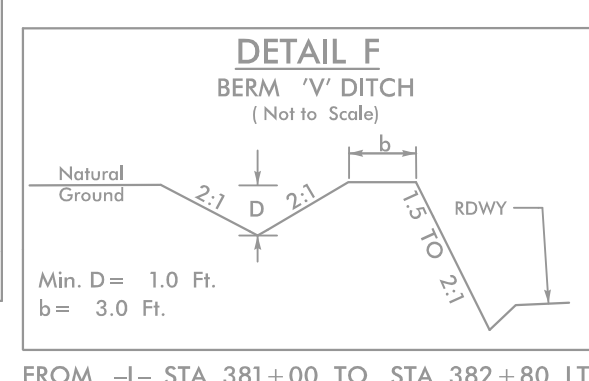
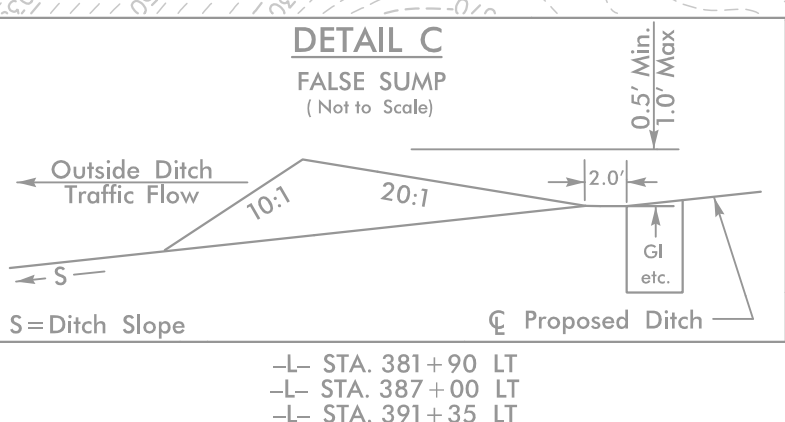

REVISIONS

11:56:23 AM
\\FS023\AM\Projects\2915C\eg_PSH14.dgn
3/28/2011 11:56:23 AM