

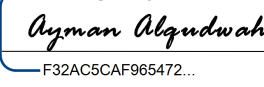

**This electronic collection of documents is provided
for the convenience of the user
and is Not a Certified Document –**

**The documents contained herein were originally issued
and sealed by the individuals whose names and license
numbers appear on each page, on the dates appearing
with their signature on that page.**

**This file or an individual page
shall not be considered a certified document.**

TIP NO. B-5936	SHEET NO. PMP-1
APPROVED:  F32AC5CAF96A72...	
DATE: 9/15/2016	
SEAL 	
DOCUMENT NOT CONSIDERED FINAL UNLESS ALL SIGNATURES COMPLETED	

**STATE OF NORTH CAROLINA
DEPARTMENT OF TRANSPORTATION**

**PAVEMENT MARKING PLAN
TYRRELL /DARE COUNTIES**

LOCATION: BRIDGE PRESERVATION PROJECT #7

T.I.P.: B-5936

CONTRACT: C203875

ROADWAY STANDARD DRAWING

THE FOLLOWING ROADWAY STANDARDS AS APPEAR IN "ROADWAY STANDARD DRAWINGS" - PROJECT SERVICES UNIT - N.C. DEPARTMENT OF TRANSPORTATION - RALEIGH, N.C., DATED JANUARY 2012 ARE APPLICABLE TO THIS PROJECT AND BY REFERENCE HEREBY ARE CONSIDERED A PART OF THESE PLANS:

STD. NO.	TITLE
1205.01	PAVEMENT MARKINGS - LINE TYPES AND OFFSETS
1205.02	PAVEMENT MARKINGS - TWO-LANE AND MULTILANE ROADWAYS
1205.12	PAVEMENT MARKINGS - BRIDGES

GENERAL NOTES

THE FOLLOWING GENERAL NOTES APPLY AT ALL TIMES FOR THE DURATION OF THE CONSTRUCTION PROJECT, EXCEPT WHEN OTHERWISE NOTED IN THE PLAN, OR DIRECTED BY THE ENGINEER.

- A) INSTALL PAVEMENT MARKINGS AND PAVEMENT MARKERS ON THE FINAL SURFACE AS FOLLOWS:

ROAD NAME	MARKING	MARKER
	POLYUREA/THERMO	RASIED

- B) TIE PROPOSED PAVEMENT MARKING LINES TO EXISTING PAVEMENT MARKING LINES.
 C) PASSING ZONES WILL BE DETERMINED IN THE FIELD AND MUST BE APPROVED BY THE ENGINEER.
 D) REMOVE ALL RESIDUE AND SURFACE LAITANCE BY ACCEPTABLE METHODS ON CONCRETE BRIDGE DECKS PRIOR TO PLACING POLYUREA PAVEMENT MARKING MATERIAL.

INDEX

SHEET NO.	DESCRIPTION
PMP-1	PAVEMENT MARKING PLAN TITLE AND
PMP-2	PAVEMENT MARKING DETAIL AND SCHEDULE SHEET

PLAN PREPARED BY: N.C.D.O.T. SIGNING AND DELINEATION UNIT

AYMAN ALQUDWAH P.E. SIGNING & DELINEATION REGIONAL ENGINEER
 BARRY NOWLIN SIGNING & DELINEATION PROJECT DESIGN ENGINEER/TECHNICIAN

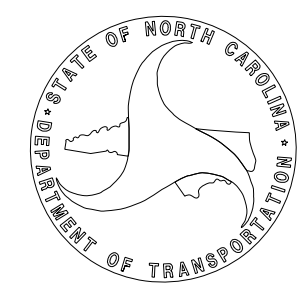

APPROVED: *Ayman Alqudwah*
F52AGSCAF988472...

DATE: 7/26/2016



**DOCUMENT NOT CONSIDERED FINAL
 UNLESS ALL SIGNATURES COMPLETED**

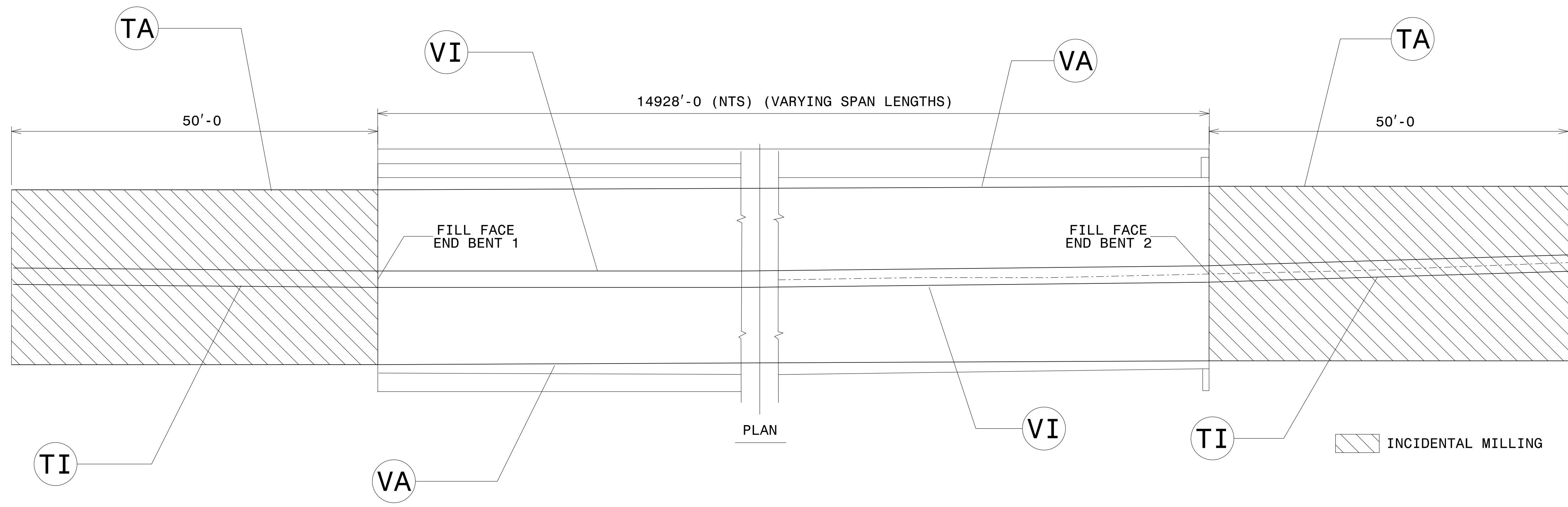

PAVEMENT MARKING SCHEDULE

SYMBOL	DESCRIPTION
TA	WHITE EDGELINE (4", 90 MIL)
TI	YELLOW DOUBLE CENTER (4", 120 MIL)
VA	WHITE EDGELINE (4")
VI	YELLOW DOUBLE CENTER (4")

PAVEMENT MARKING DETAIL

7/26/2016 N:\Special\581333\Tr\of\ic\Signing\CADD\B-5936_Sgn_PMP_Sheets.dgn User:walterjohnson