

**NOTES:**

REPAIR LOCATIONS AND ESTIMATE OF QUANTITIES ARE GIVEN WITH THE BEST INFORMATION AVAILABLE. IF ADDITIONAL REPAIRS NOT SHOWN ON THE DRAWINGS ARE DEEMED NECESSARY BY THE INSPECTOR OR ENGINEER THE CONTRACTOR SHALL NOTE ON THE DRAWINGS THE APPROXIMATE LOCATION AND DESCRIPTION OF THE REPAIRS AND ADJUST THE ACTUAL QUANTITIES ENTERED INTO THE REPAIR QUANTITY TABLE.

FOR CAP REPAIR DETAILS, SEE "TYPICAL CAP REPAIR DETAILS" SHEET.

FOR "SHOTCRETE REPAIRS", SEE SPECIAL PROVISIONS.

FOR "EPOXY RESIN INJECTION", SEE SPECIAL PROVISIONS.

**REPAIR QUANTITY TABLE**

| REPAIRS BENT 142         | QUANTITIES |           |         |           |
|--------------------------|------------|-----------|---------|-----------|
|                          | ESTIMATE   |           | ACTUAL  |           |
| SHOTCRETE REPAIRS        | AREA SF    | VOLUME CF | AREA SF | VOLUME CF |
| CAP (VERTICAL FACE)      | 5.3        | 2.2       |         |           |
| CAP (HORIZONTAL, CORNER) | 0.0        | 0.0       |         |           |
| EPOXY RESIN INJECTION    |            | LN. FT.   |         | LN. FT.   |
| CAP                      |            | 0.0       |         |           |

VALUES IN CHART REPRESENT ESTIMATED REPAIR TOTALS AFTER REMOVAL OF UNSOUND CONCRETE, MIN. OF 1" BEHIND REBAR AND MIN. 2" CL TO SAWCUT. SEE REPAIR DETAILS.



SPAN 143  
SPAN 142

PLAN  
TOP OF CAP

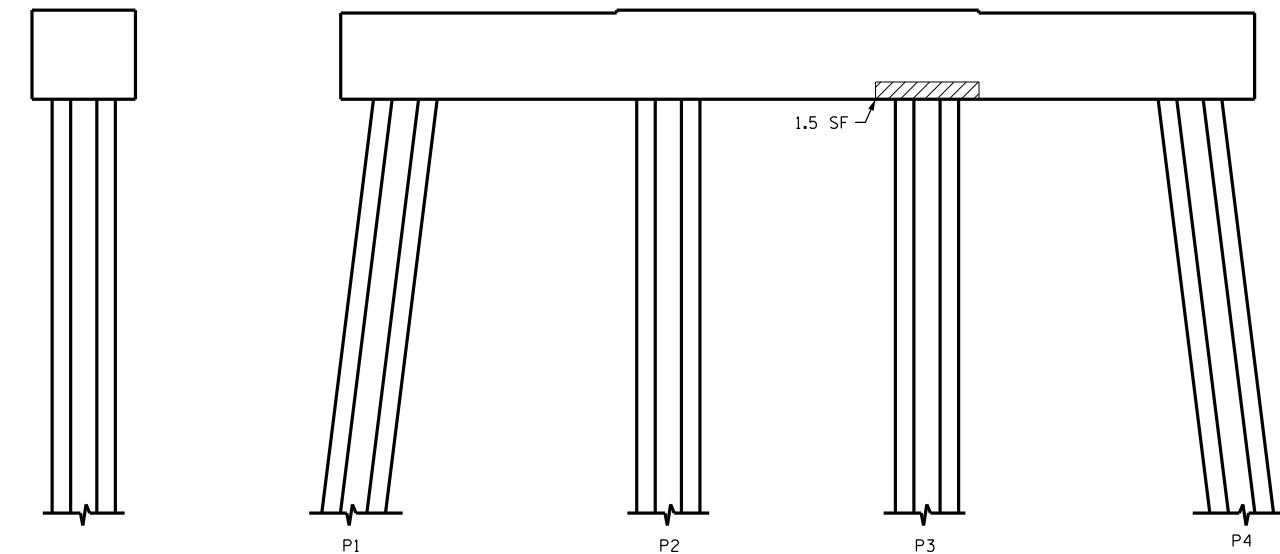

END VIEW  
NORTH SIDE

ELEVATION  
WEST SIDE

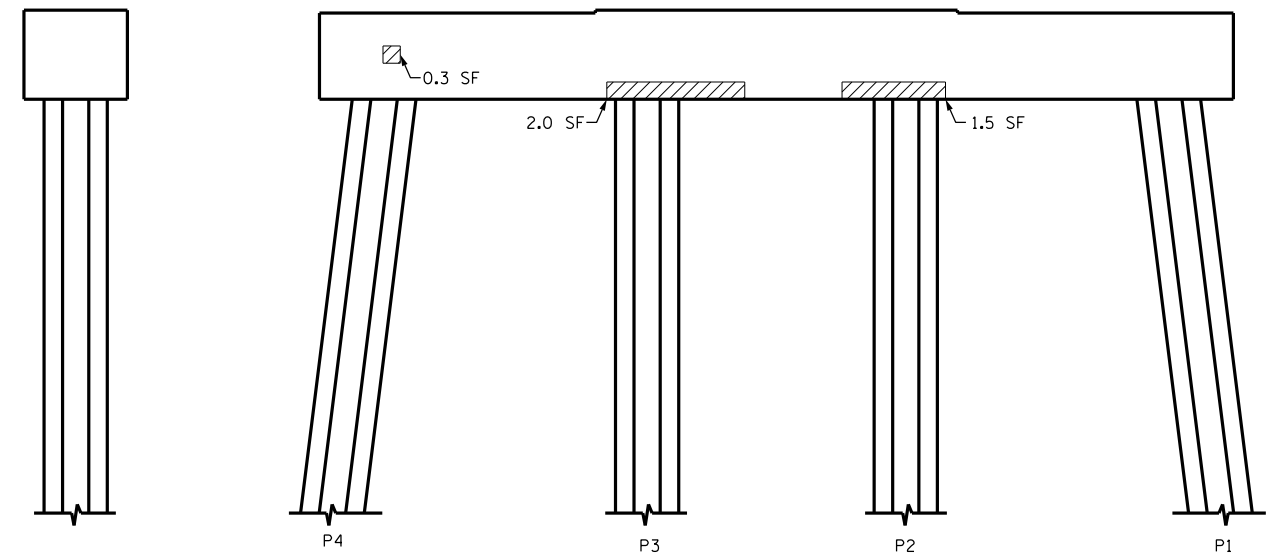

END VIEW  
SOUTH SIDE

ELEVATION  
EAST SIDE

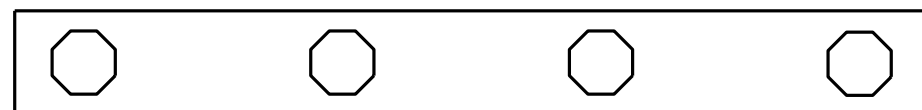

SPAN 142  
SPAN 143

PLAN  
BOTTOM OF CAP

- SHOTCRETE REPAIR  
 - EPOXY RESIN INJECTION

PROJECT NO. B-5936  
TYRRELL COUNTY  
BRIDGE NO. 7

DocuSigned by:  
*Paul Bryant*  
3653D2AF1B77448...

8/10/2016



STATE OF NORTH CAROLINA  
DEPARTMENT OF TRANSPORTATION  
RALEIGH

**BENT 142**

DRAWN BY : P. D. BRYANT DATE : 4-2016  
CHECKED BY : W. M. CLARKE DATE : 4-2016

DOCUMENT NOT CONSIDERED  
FINAL UNLESS ALL  
SIGNATURES COMPLETED

| REVISIONS |     |       |     |     |       | SHEET NO.    |
|-----------|-----|-------|-----|-----|-------|--------------|
| NO.       | BY: | DATE: | NO. | BY: | DATE: | TOTAL SHEETS |
| 1         |     |       | 3   |     |       | S-183        |
| 2         |     |       | 4   |     |       | 394          |