

DOCUMENT NOT CONSIDERED FINAL
UNLESS ALL SIGNATURES COMPLETED

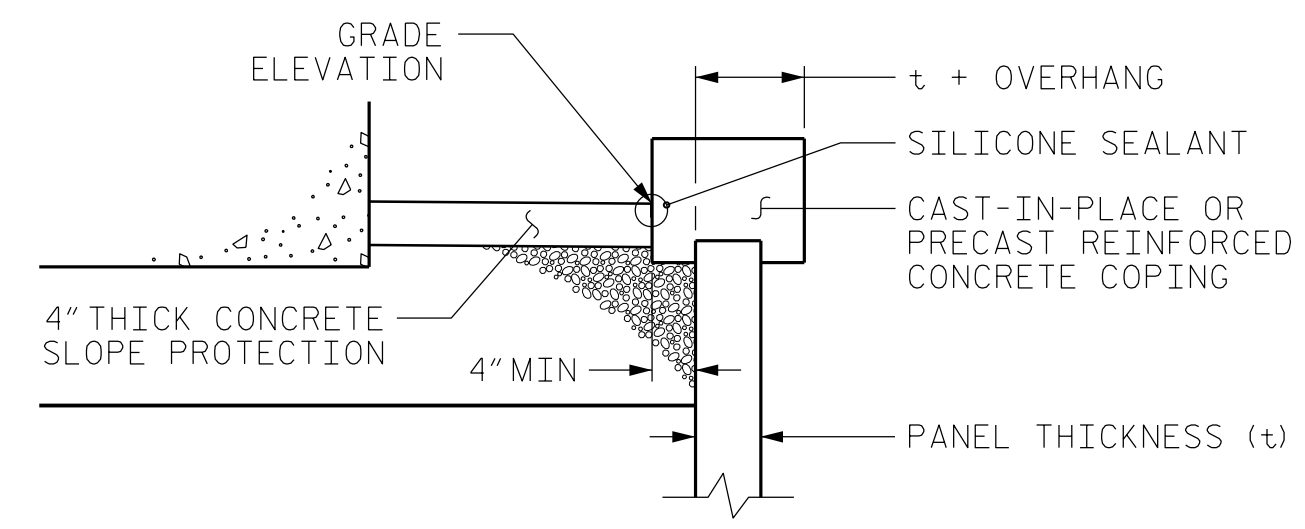
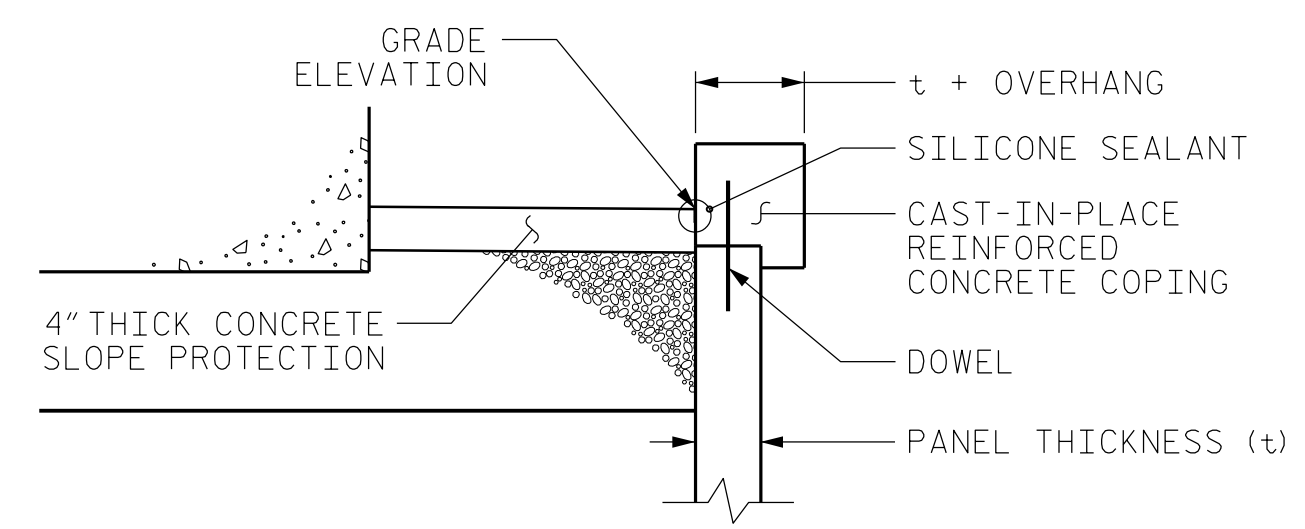
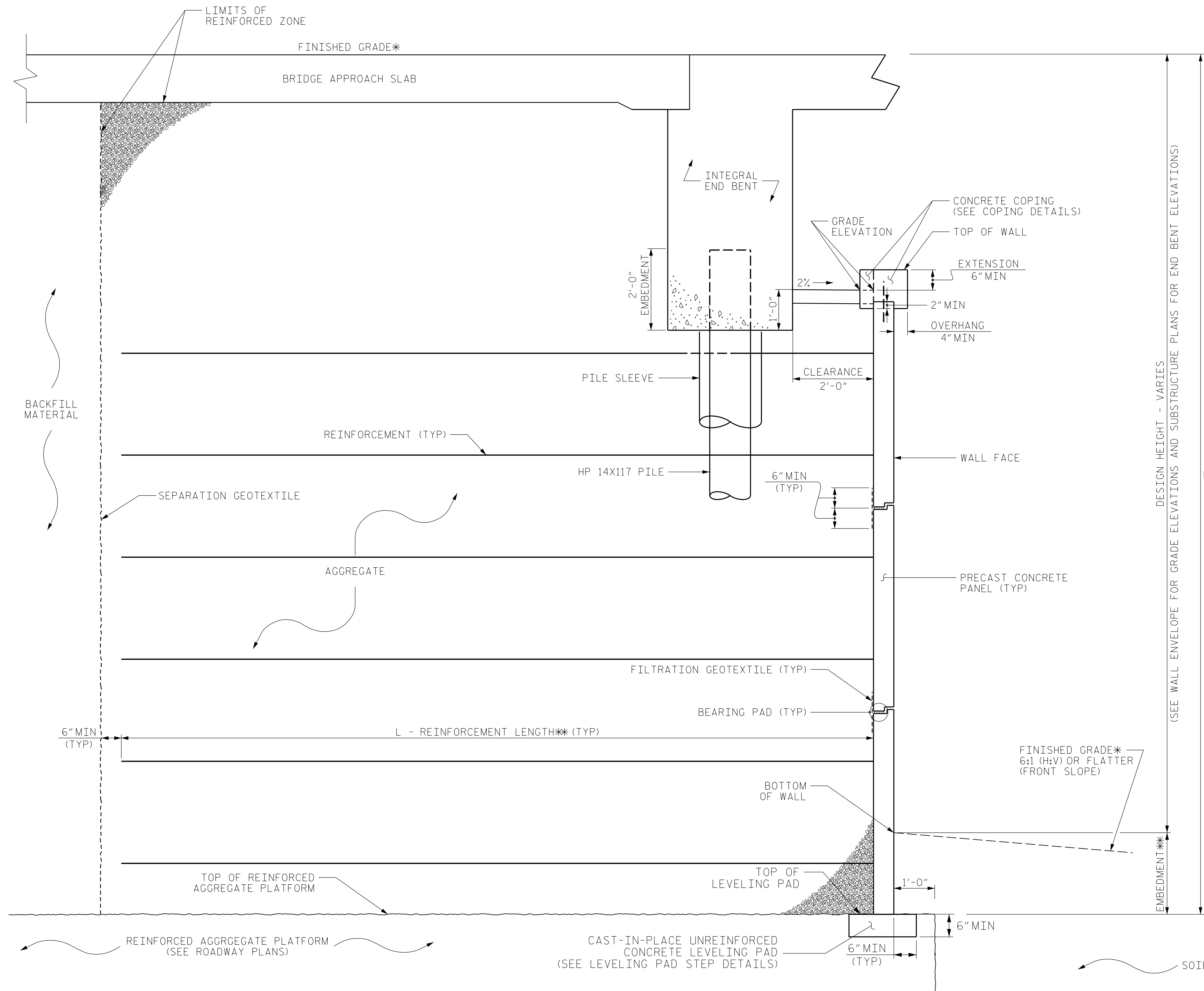

COPING DETAILS

AT THE CONTRACTOR'S OPTION, CONNECT COPING TO PANELS WITH DOWELS OR EXTEND COPING DOWN BACK OF PANELS.

MSE ABUTMENT WALL WITH PRECAST PANELS - TYPICAL SECTION

*SEE ROADWAY PLANS FOR FINISHED GRADE DETAILS.
**SEE MSE RETAINING WALLS PROVISION AND IF APPLICABLE, MSE WALL NOTES FOR EMBEDMENT AND REINFORCEMENT LENGTH REQUIREMENTS.

PROJECT NO.: R-5769
JOHNSTON COUNTY
STATION: 33+26.33 -L-

SHEET 5 OF 6

PREPARED BY: M. J. ALEXANDER	DATE: 06/2016
REVIEWED BY: A. A. NASH	DATE: 06/2016

Terracon
Consulting Engineers & Scientists
2401 BRENTWOOD ROAD, SUITE 107
RALEIGH, NORTH CAROLINA 27604
PHONE: (919) 873-2211 FAX: (919) 873-9555
NC REGISTERED FIRM: F-0869

**MSE RETAINING WALL
TYPICAL SECTION
WITH BRIDGE PILES**

REVISIONS						SHEET NO.
NO.	BY	DATE	NO.	BY	DATE	
1	MJA	07/2016	3			W-5
2			4			