

**This electronic collection of documents is provided
for the convenience of the user
and is Not a Certified Document –**

**The documents contained herein were originally issued
and sealed by the individuals whose names and license
numbers appear on each page, on the dates appearing
with their signature on that page.**

**This file or an individual page
shall not be considered a certified document.**

TIP NO. U-2524D	SHEET NO. PMP - 1
APPROVED: <u>Rhonda B. Early</u> <small>—F34CAF5AC8BF4BA—</small>	
DATE: 5/4/2016	
	
DOCUMENT NOT CONSIDERED FINAL UNLESS ALL SIGNATURES COMPLETED	

**STATE OF NORTH CAROLINA
DEPARTMENT OF TRANSPORTATION**

**PAVEMENT MARKING PLAN
GUILFORD COUNTY**

T.I.P.: U-2524D

CONTRACT: 34820.2.19

INDEX

SHEET NO.	DESCRIPTION
PMP-1	PAVEMENT MARKING PLAN TITLE SCHEDULE SHEET, ROADWAY STANDARD DRAWINGS AND GENERAL NOTES
PMP-1A	FINAL PAVEMENT MARKING SCHEDULE
PMP-1B	CROSSWALK PAVEMENT MARKING GUIDANCE DETAIL
PMP-2-12	PAVEMENT MARKING DETAILS

ROADWAY STANDARD DRAWING

THE FOLLOWING ROADWAY STANDARDS AS APPEAR IN "ROADWAY STANDARD DRAWINGS" - PROJECT SERVICES UNIT - N.C. DEPARTMENT OF TRANSPORTATION - RALEIGH, N.C., DATED JANUARY 2012 ARE APPLICABLE TO THIS PROJECT AND BY REFERENCE HEREBY ARE CONSIDERED A PART OF THESE PLANS:

STD. NO.	TITLE
1205.01	PAVEMENT MARKINGS - LINE TYPES AND OFFSETS
1205.02	PAVEMENT MARKINGS - TWO-LANE AND MULTILANE ROADWAYS
1205.03	PAVEMENT MARKINGS - EXIT AND ENTRANCE RAMPS
1205.04	PAVEMENT MARKINGS - INTERSECTIONS
1205.05	PAVEMENT MARKINGS - TURN LANES
1205.06	PAVEMENT MARKINGS - LANE DROPS
1205.08	PAVEMENT MARKINGS - SYMBOLS AND WORD MESSAGES
1205.09	PAVEMENT MARKINGS - PAINTED ISLANDS
1205.12	PAVEMENT MARKINGS - BRIDGES
1205.13	PAVEMENT MARKINGS - LANE REDUCTIONS
1250.01	RAISED PAVEMENT MARKERS - INSTALLATION SPACING
1251.01	RAISED PAVEMENT MARKERS - PERMANENT AND TEMPORARY
1253.01	RAISED PAVEMENT MARKERS - SNOWPLOWABLE
1261.01	GUARDRAIL AND BARRIER DELINEATORS - INSTALLATION SPACING
1261.02	GUARDRAIL AND BARRIER DELINEATORS - TYPES AND MOUNTING
1262.01	GUARDRAIL END DELINEATION

GENERAL NOTES

THE FOLLOWING GENERAL NOTES APPLY AT ALL TIMES FOR THE DURATION OF THE CONSTRUCTION PROJECT, EXCEPT WHEN OTHERWISE NOTED IN THE PLAN, OR DIRECTED BY THE ENGINEER.

- A) INSTALL PAVEMENT MARKINGS AND PAVEMENT MARKERS ON THE FINAL SURFACE AS FOLLOWS:

ROAD NAME	MARKING	MARKER
GREENSBORO-WESTERN LOOP AND Y LINES	POLYUREA WITH HIGHLY REFLECTIVE ELEMENTS	SNOWPLOWABLE (MATCH EXISTING Y LINES)
CONCRETE BRIDGE DECKS	POLYUREA WITH HIGHLY REFLECTIVE ELEMENTS	RAISED

- B) USE HEATED-IN PLACE THERMOPLASTIC OR EXTRUDED THERMOPLASTIC MARKINGS FOR STOP BARS, SYMBOLS, CHARACTERS AND DIAGONALS.
- C) TIE PROPOSED PAVEMENT MARKING LINES TO EXISTING PAVEMENT MARKING LINES.
- D) REMOVE/REPLACE ANY CONFLICTING/DAMAGED PAVEMENT MARKINGS AND MARKERS.
- E) PASSING ZONES WILL BE DETERMINED IN THE FIELD AND MUST BE APPROVED BY THE ENGINEER.
- F) STOP BAR LOCATION AT NON-SIGNALIZED INTERSECTIONS MAY BE ADJUSTED AS DIRECTED BY THE ENGINEER.
- G) REMOVE ALL RESIDUE AND SURFACE LAITANCE BY ACCEPTABLE METHODS ON CONCRETE SURFACES PRIOR TO PLACING POLYUREA PAVEMENT MARKING MATERIAL.
- H) MARKERS SHALL BE INSTALLED ACCORDING TO THE NCDOT ROADWAY STANDARD DRAWING 1250.01.
- I) SEE ROADWAY PLANS FOR ALTERNATE CURB RAMP DESIGNS WHEN INDICATED ON PAVEMENT MARKING DETAIL SHEETS.

PLAN REVIEWED BY: N.C.D.O.T. SIGNING AND DELINEATION UNIT

R. B. Roach, PE SIGNING & DELINEATION STANDARDS ENGINEER
S. D. Coleman SIGNING & DELINEATION PROJECT DESIGN ENGINEER

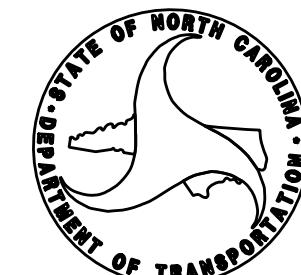

PLAN PREPARED BY: HNTB NORTH CAROLINA, P.C.

R. B. Early, PE PROJECT ENGINEER
J. A. Phillips PROJECT DESIGNER

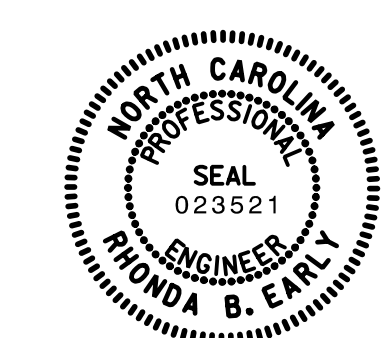

HNTB NORTH CAROLINA, P.C.
343 E. Six Forks Road, Suite 200
Raleigh, North Carolina 27609
C-1554

TIP NO. U-2524D	SHEET NO. PMP-1A
Approved by: <i>Rhonda B. Early</i> F34CAFAC6BF48A...	
DATE: 5/4/2016	
SEAL 	
DOCUMENT NOT CONSIDERED FINAL UNLESS ALL SIGNATURES COMPLETED	

FINAL PAVEMENT MARKING SCHEDULE

MATERIAL	SYMBOL	DESCRIPTION
PAVEMENT MARKING		
<u>POLYUREA (4") HIGHLY REFLECTIVE ELEMENTS</u>		
	V8	2'-6' WHITE MINISKIP
	VA	WHITE EDGELINE
	VB	YELLOW EDGELINE
	VC	10' WHITE SKIP
	VD	3'-9' WHITE MINI KIP
	VE	WHITE SOLID LANE LINE
	VF	10' YELLOW SKIP
	VH	YELLOW SINGLE CENTER
	VI	YELLOW DOUBLE CENTER
<u>POLYUREA (6") HIGHLY REFLECTIVE ELEMENTS</u>		
	V6	WHITE EDGELINE
	V7	YELLOW EDGELINE
	V11	2'-6' WHITE MINISKIP
	VJ	10' WHITE SKIP
	VK	3'-9' WHITE MINISKIP
	VL	WHITE LANE LINE
<u>POLYUREA (8") HIGHLY REFLECTIVE ELEMENTS</u>		
	VN	WHITE GORELINE
<u>POLYUREA (12") HIGHLY REFLECTIVE ELEMENTS</u>		
	VS	WHITE GORELINE
	VT	WHITE SOLID LANE LINE

MATERIAL	SYMBOL	DESCRIPTION
PAVEMENT MARKING		
<u>THERMOPLASTIC (8", 90 MILS)</u>		
	TP	YELLOW DIAGONAL
<u>THERMOPLASTIC (8", 120 MILS)</u>		
	TQ	WHITE CROSSWALK LINE
<u>THERMOPLASTIC (24", 120 MILS)</u>		
	T2	WHITE STOP BAR
	T3	WHITE CROSSWALK LINE
<u>THERMOPLASTIC SYMBOL (90 MILS)</u>		
	UA	LEFT TURN ARROW
	UB	RIGHT TURN ARROW
	UC	STRAIGHT ARROW
	UN	24" YIELD LINE
	UP	MERGE ARROW
	UQ	RAMP ARROW
<u>PERMANENT RAISED PAVEMENT MARKERS</u>		
	MA	YELLOW & YELLOW CRYSTAL & RED
	MB	CRYSTAL & RED
<u>SNOWPLOWABLE PAVEMENT MARKERS</u>		
	ME	YELLOW & YELLOW CRYSTAL & RED
	MF	CRYSTAL & RED

LEGEND

- GENERAL**
- DIRECTION OF TRAFFIC FLOW
 - NORTH ARROW
 - PROPOSED PVMT. EXIST. PVMT.

- PAVEMENT MARKINGS**
- PAVEMENT MARKING SYMBOLS

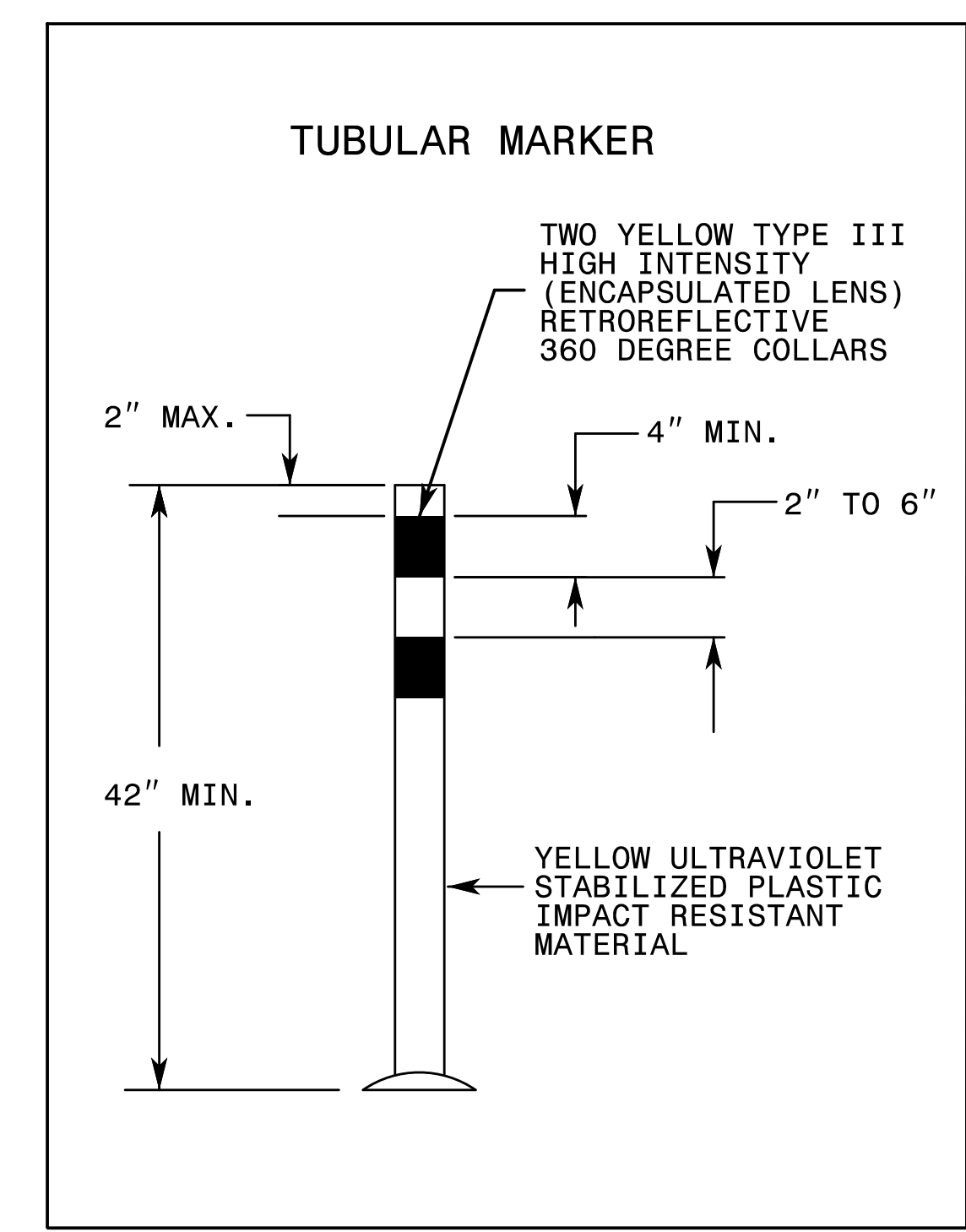

2:44:52 PM
 \\PMP\U2524D_PMP_PMP01A.dgn
 \$\$\$USERNAME\$\$\$



FINAL PAVEMENT MARKING SCHEDULE

UNLESS OTHERWISE SPECIFIED,
HI-VISIBILITY CROSSWALK
MARKINGS SHALL BE USED AT
MID-BLOCK CROSSINGS

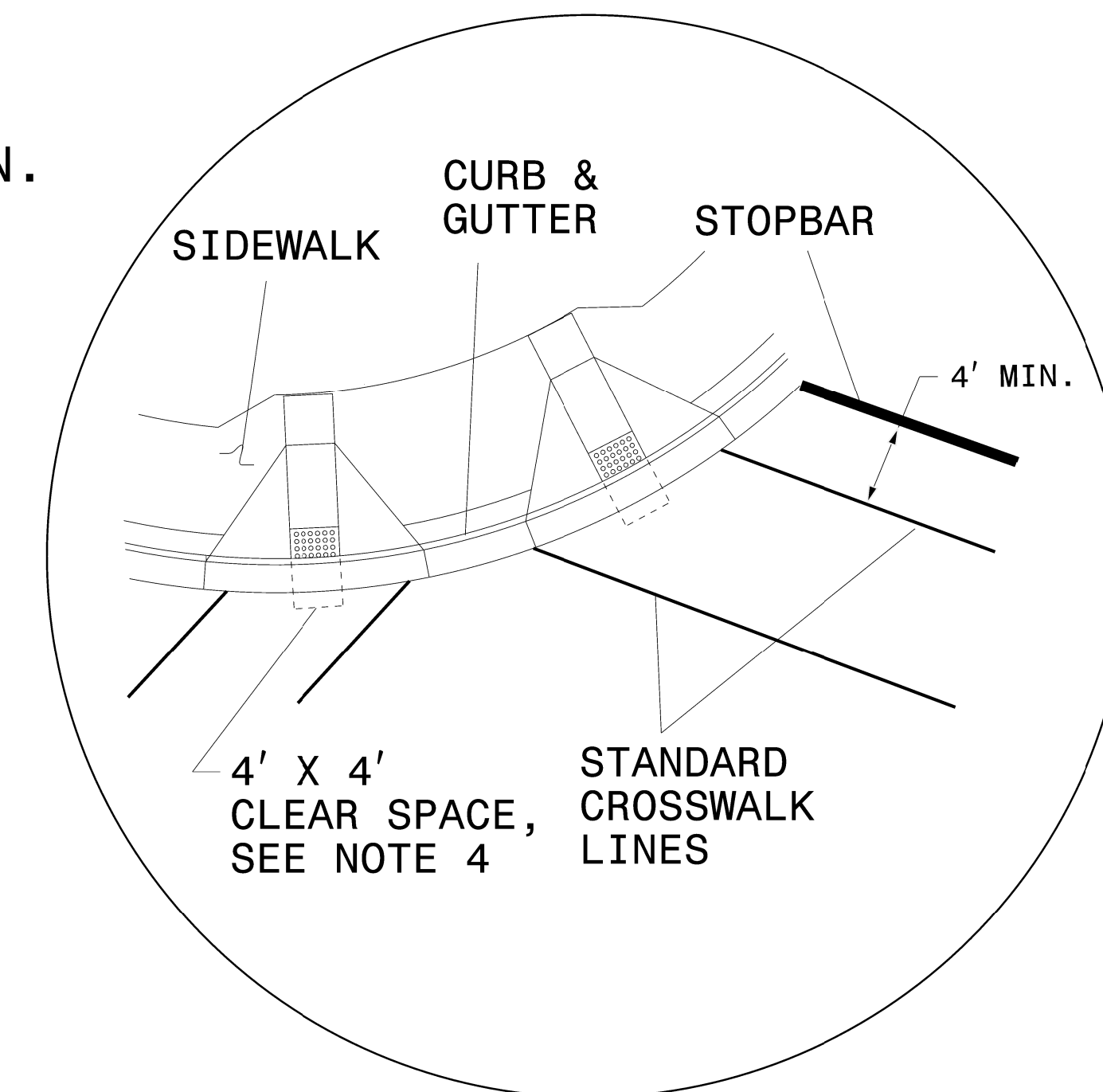
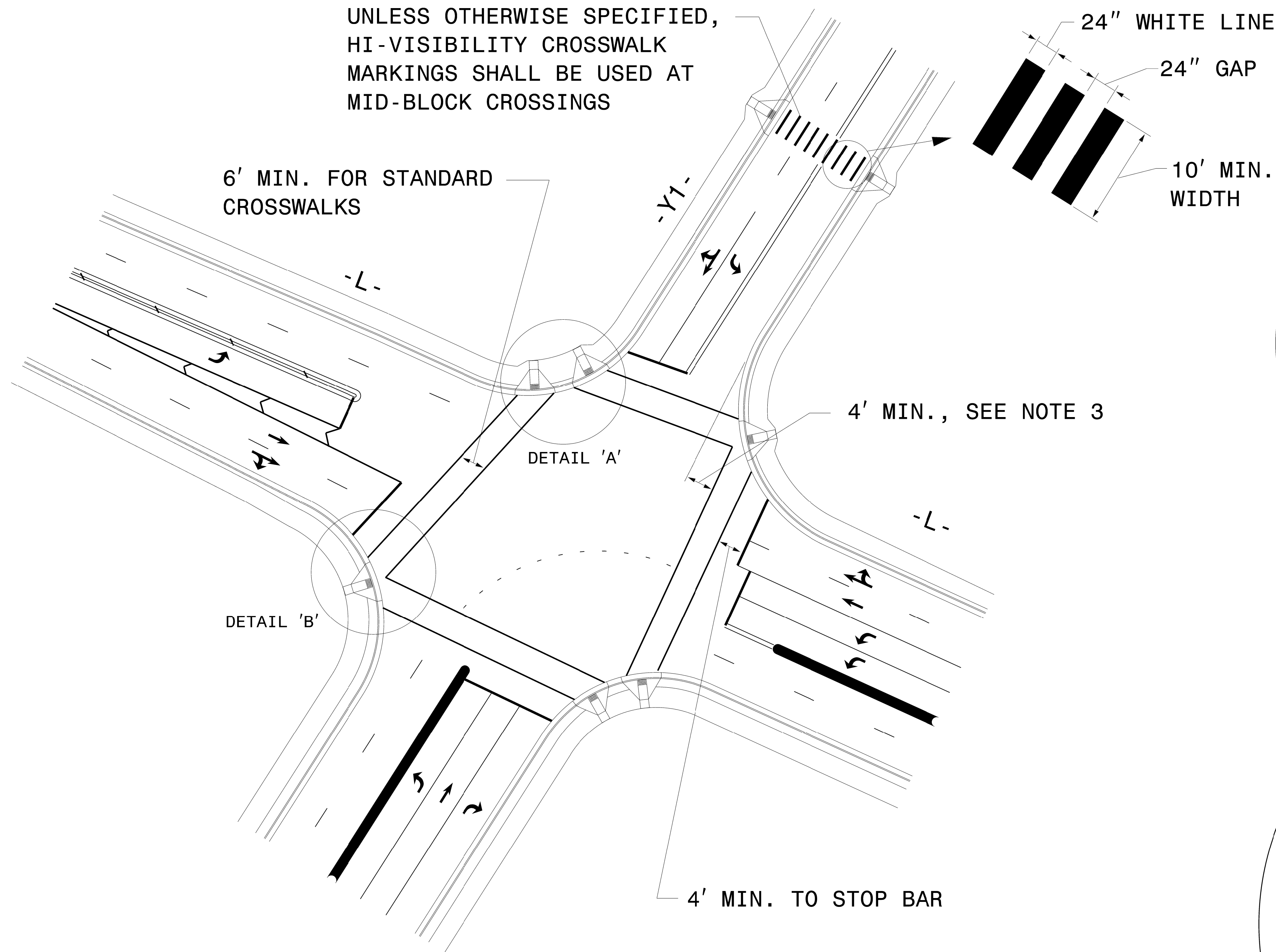

DETAIL 'A'- DUAL CURB RAMPS

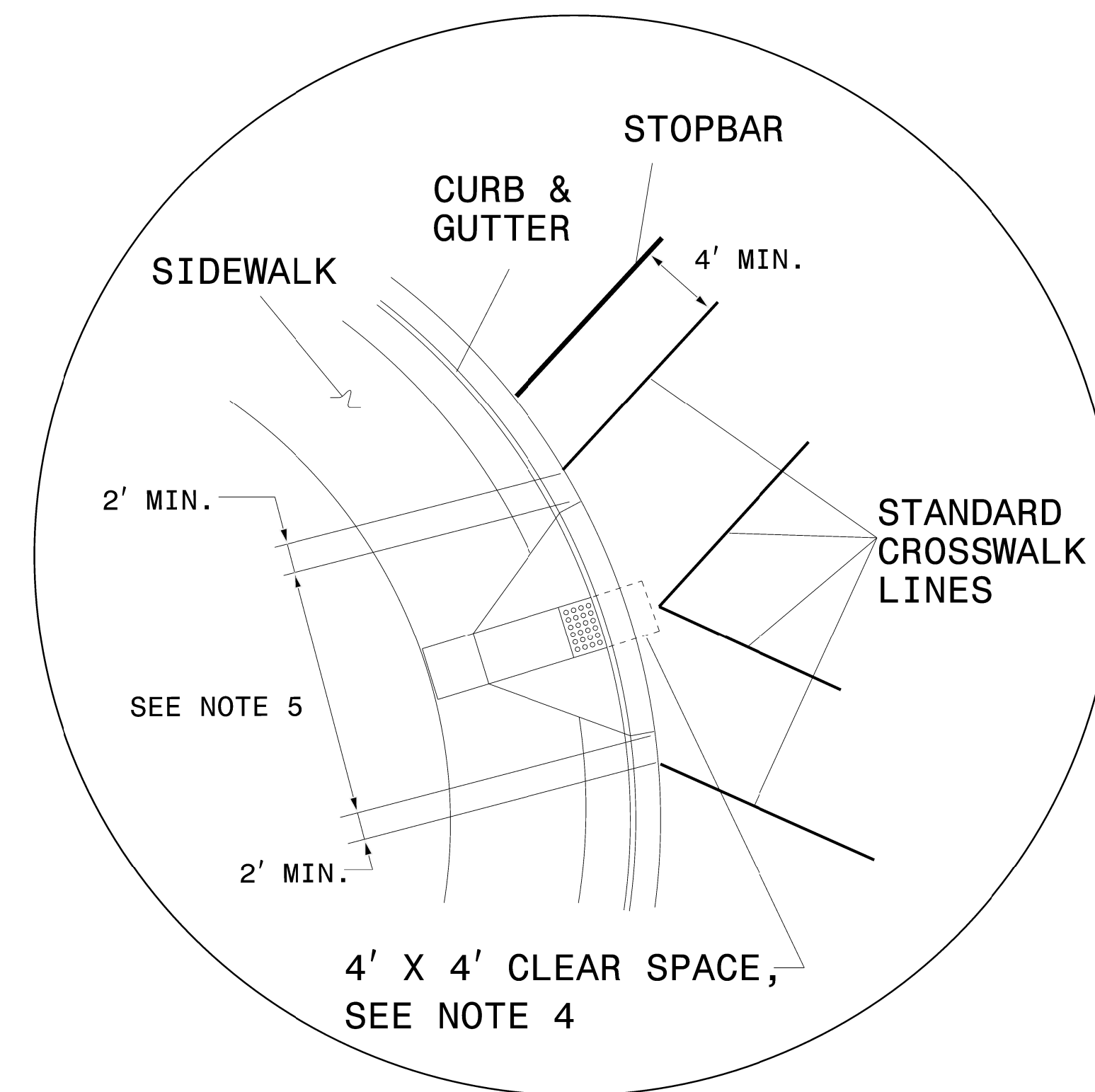

DETAIL 'B'- SINGLE DIAGONAL CURB RAMP

GUIDANCE DETAIL FOR CROSSWALK MARKINGS

NOTES:

1. USE THE DETAILS ABOVE AND THE FOLLOWING NOTES FOR GUIDANCE IN PLACING CROSSWALK MARKINGS NOT STATIONED ON THE DETAIL SHEETS OR WHEN FIELD ADJUSTMENTS REQUIRED MOVING STATIONED MARKINGS AS DIRECTED BY THE ENGINEER. REFER TO NCDOT ROADWAY STANDARD DRAWINGS, MUTCD AND ADA STANDARDS FOR ADDITIONAL GUIDANCE.
2. THE CROSSWALK MARKINGS SHOWN ON THE ABOVE DETAILS ARE FOR REFERENCE ONLY. ONLY INSTALL CROSSWALK MARKINGS WHERE SHOWN ON THE DETAIL SHEETS OR AS DIRECTED BY THE ENGINEER. THE CROSSWALK MARKING TYPE, STANDARD OR HI-VISIBILITY, SHALL BE INSTALL AS SPECIFIED ON THE DETAIL SHEETS OR AS DIRECTED BY THE ENGINEER.
3. SET BACK DISTANCE FROM INSIDE CROSSWALK MARKING TO NEAREST EDGE OF TRAVEL IS 4' MIN.
4. BEYOND THE BOTTOM GRADE BRAKE, A CLEAR SPACE OF 4' X 4' MINIMUM SHALL BE PROVIDED WITHIN THE MARKINGS.
5. SINGLE DIAGONAL CURB RAMPS WITH FLARED SIDES SHALL HAVE A SEGMENT OF CURB 2 FEET LONG MINIMUM LOCATED ON EACH SIDE OF THE CURB RAMP AND WITHIN THE MARKED CROSSING, SEE DETAIL 'B'.
6. CURB RAMPS SHALL BE CONSTRUCTED IN ACCORDANCE TO THE LATEST NCDOT ROADWAY STANDARD DRAWINGS.

**CROSSWALK PAVEMENT MARKING
GUIDANCE DETAIL**

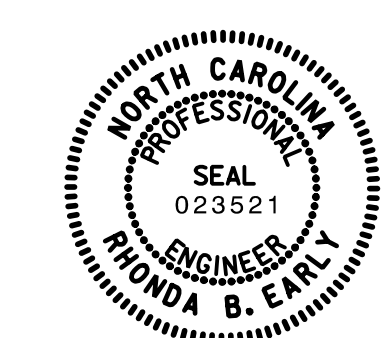
TIP NO. U-2524D	SHEET NO. PMP-2
APPROVED: <i>Rhonda B. Early</i> <small>F34CAF5AC6BF48A</small>	
DATE: 5/4/2016	
SEAL	
	
DOCUMENT NOT CONSIDERED FINAL UNLESS ALL SIGNATURES COMPLETED	

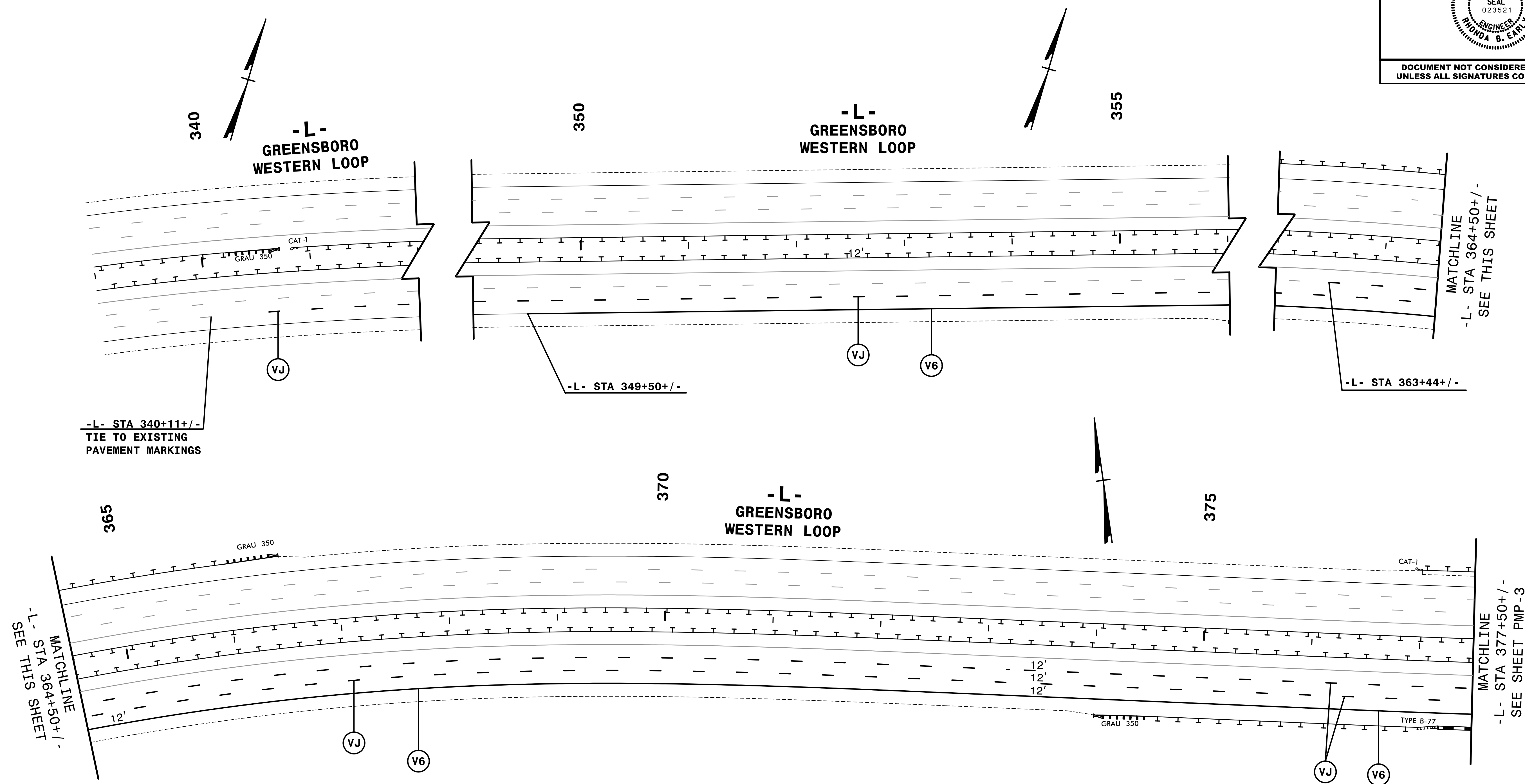

REMOVE TEMPORARY PAVEMENT MARKINGS
AND SYMBOLS PLACED IN U-2524C

HNTB HNTB NORTH CAROLINA, P.C.
343 E. SIX FORKS ROAD, SUITE 200
RALEIGH, NORTH CAROLINA 27609
NC LICENSE NO: C-1554

PAVEMENT MARKING DETAIL

2:45:14 PM
\\PMP\U2524D_PMP_PMP02.dgn
\$\$\$\$\$USERNAME\$\$\$\$\$

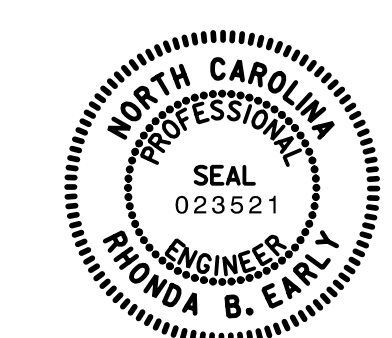
TIP NO. U-2524D	SHEET NO. PMP-3
APPROVED: <i>Rhonda B. Early</i> <small>F34CAF5AC8BF48A</small>	
DATE: 5/4/2016	
SEAL	
	
DOCUMENT NOT CONSIDERED FINAL UNLESS ALL SIGNATURES COMPLETED	

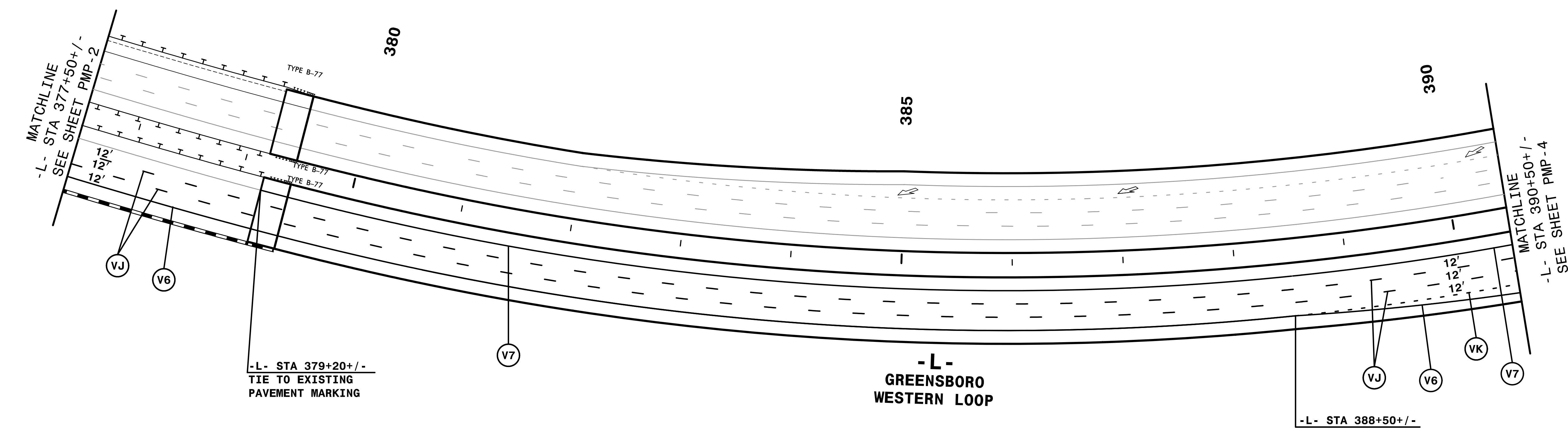

2:45:19 PM
 \\PMP\U2524D_PMP_PMP03.dgn
 \$\$\$USERNAME\$\$\$

REMOVE TEMPORARY PAVEMENT MARKINGS
AND SYMBOLS PLACE IN U-2524C

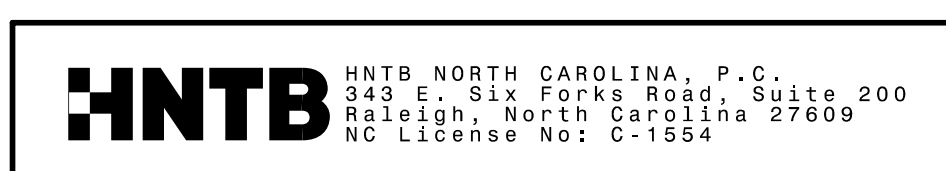

PAVEMENT MARKING DETAIL

TIP NO. U-2524D	SHEET NO. PMP-4
APPROVED: <i>Rhonda B. Early</i> F34CAF5AC8BF48A	
DATE: 5/4/2016	
SEAL	
	
DOCUMENT NOT CONSIDERED FINAL UNLESS ALL SIGNATURES COMPLETED	

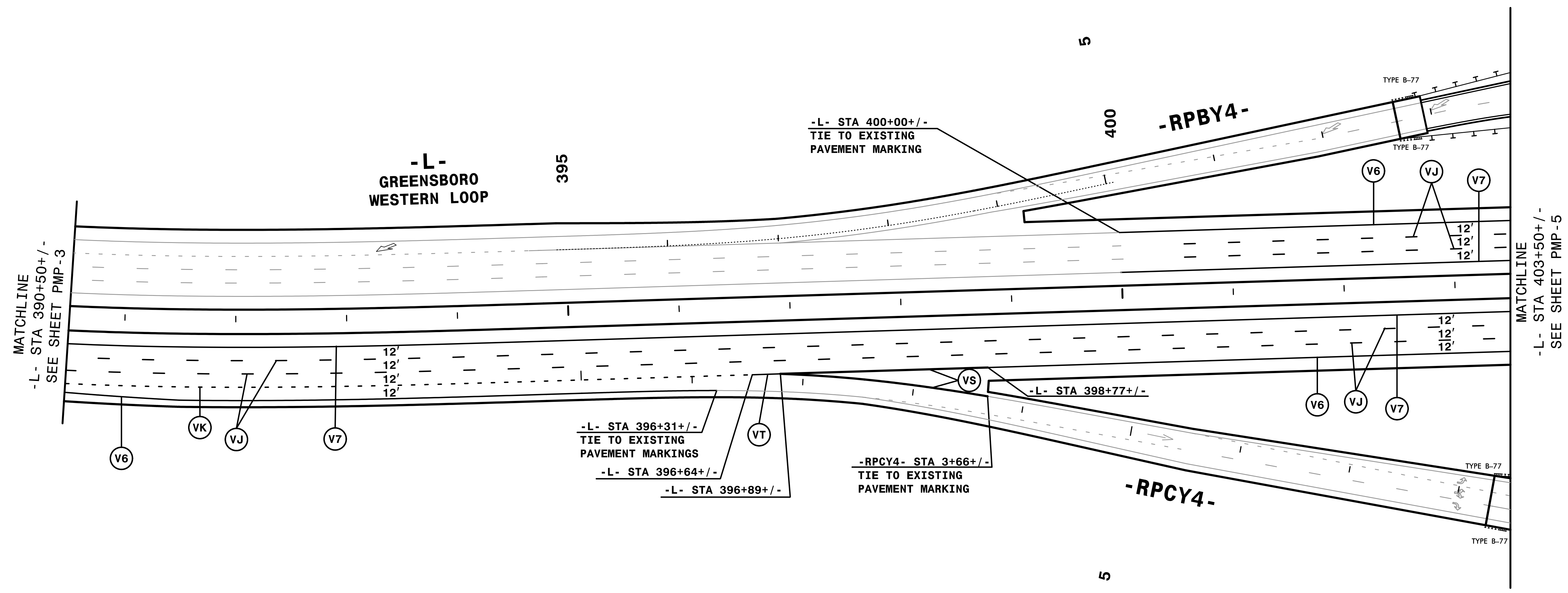
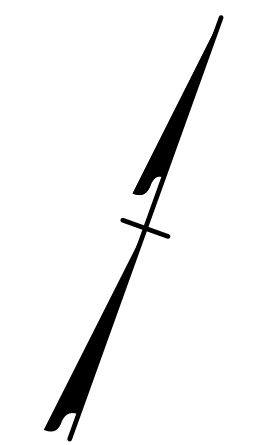

REMOVE TEMPORARY PAVEMENT MARKINGS
AND SYMBOLS PLACE IN U-2524C

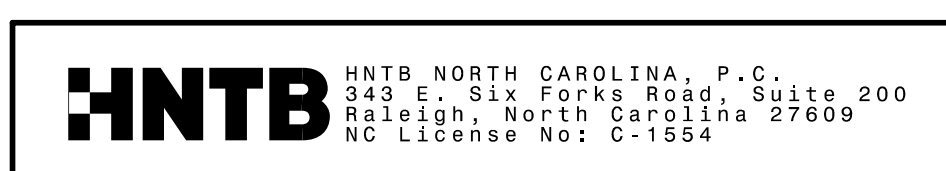

PAVEMENT MARKING DETAIL

2:45:25 PM
\\PMP\U2524D_PMP_PMP04.dgn
\$\$\$\$\$USERNAME\$\$\$\$\$

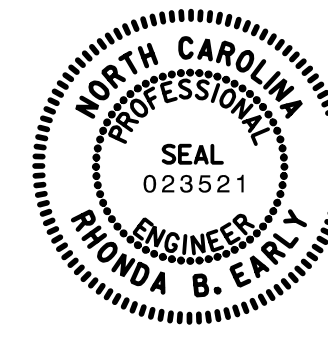
TIP NO. U-2524D	SHEET NO. PMP-6
APPROVED: <i>Rhonda B. Early</i> <small>Drawn/Checked by: Rhonda B. Early F34CAFAC8BF48A</small>	
DATE: 5/4/2016	
SEAL	
	
DOCUMENT NOT CONSIDERED FINAL UNLESS ALL SIGNATURES COMPLETED	

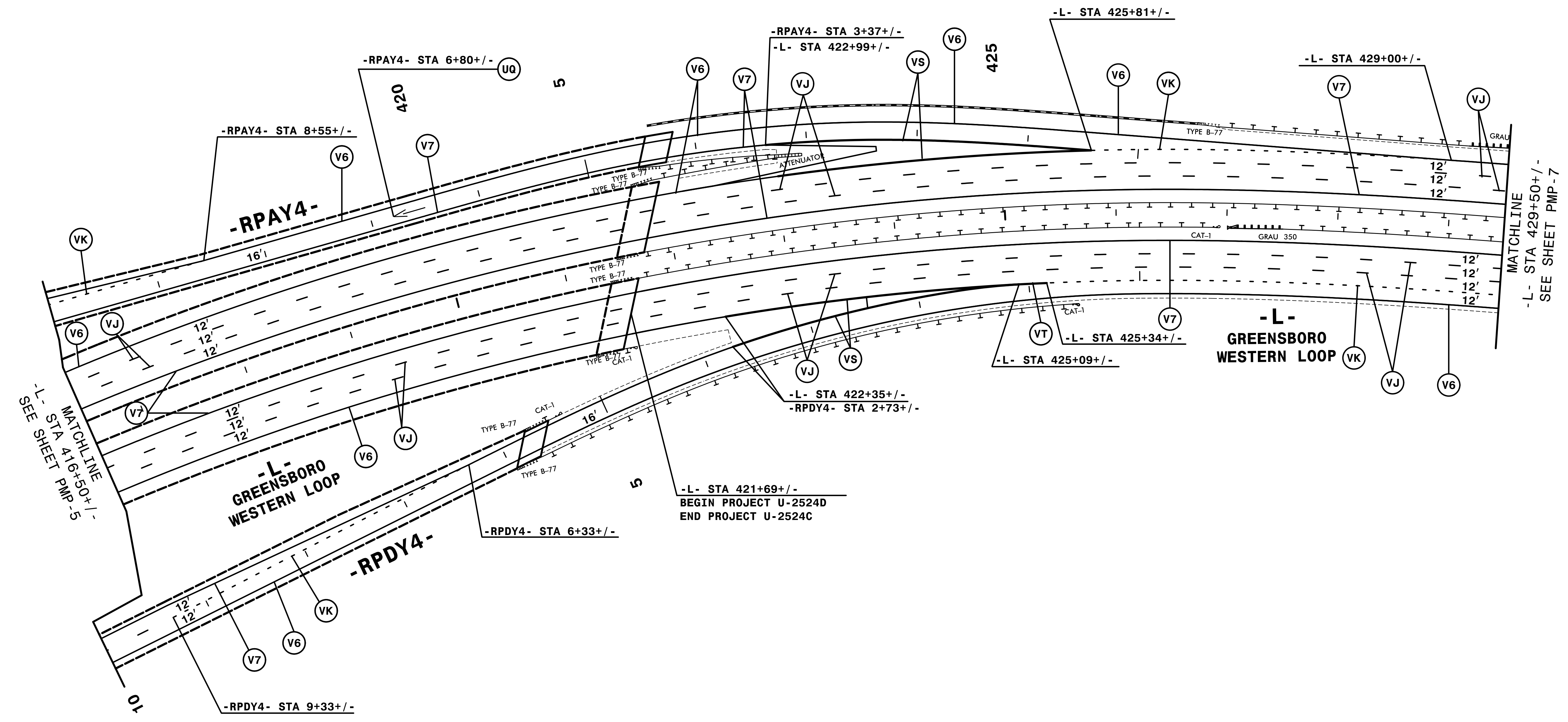

2:45:37 PM
\\PMP\U2524D_PMP_PMP06.dgn
\$\$\$\$\$USERNAME\$\$\$\$\$

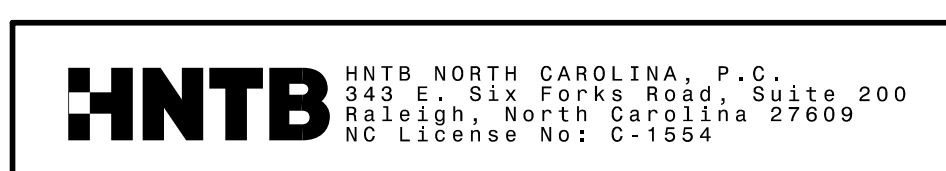

PAVEMENT MARKING DETAIL

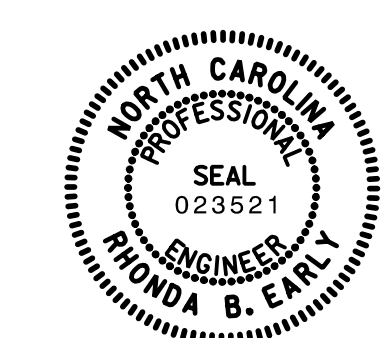
TIP NO. U-2524D	SHEET NO. PMP-7
APPROVED: <i>Rhonda B. Early</i> <small>F34CAF5AC6BF48A...</small>	
DATE: 5/4/2016	
SEAL	
	
DOCUMENT NOT CONSIDERED FINAL UNLESS ALL SIGNATURES COMPLETED	

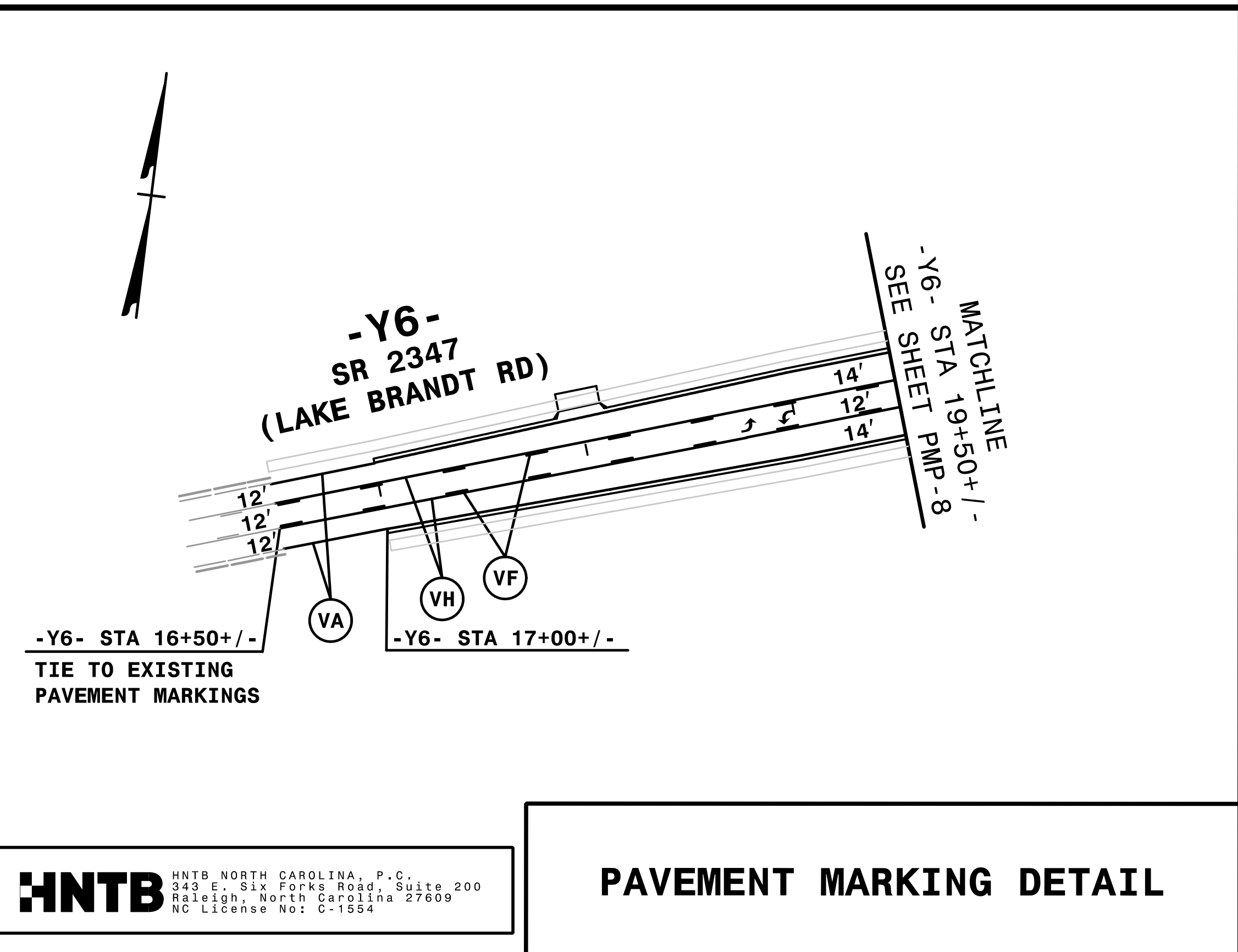
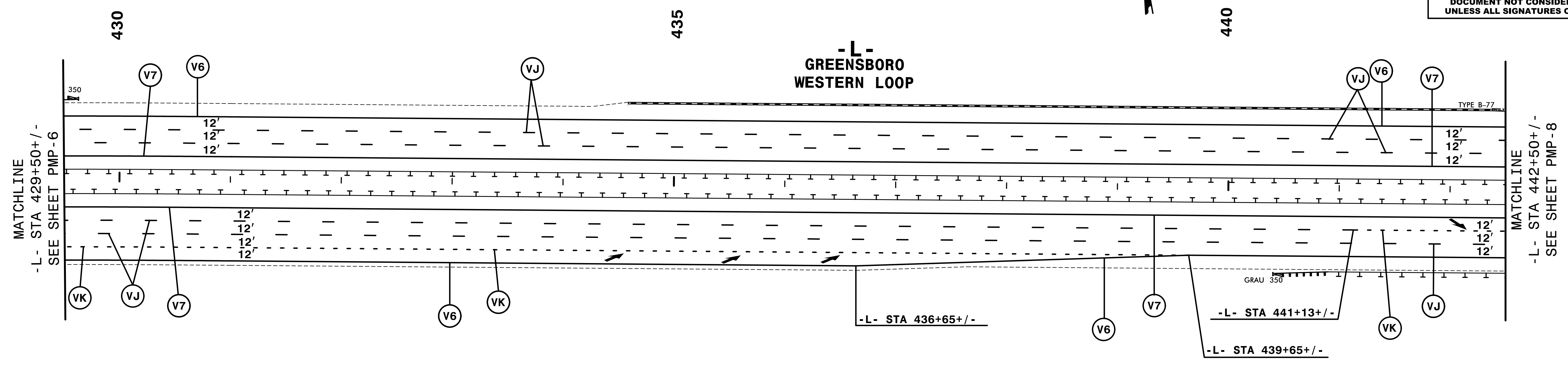

HNTB HNTB NORTH CAROLINA, P.C.
343 E. SLX FORKS ROAD, SUITE 200
RALEIGH, NORTH CAROLINA 27609
NC LICENSE NO: C-1554

PAVEMENT MARKING DETAIL

2:45:44 PM
\\PMP\U2524D_PMP_PMP07.dgn
\$\$\$USERNAME\$\$\$

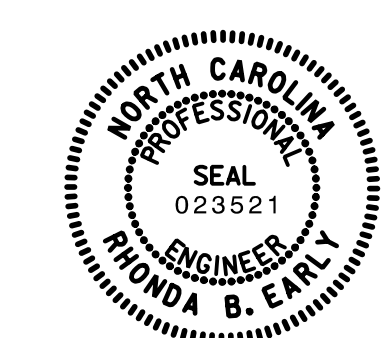
TIP NO. U-2524D	SHEET NO. PMP-8
APPROVED: <i>Rhonda B. Early</i> <small>Professional Engineer F34CAFACB8F8A8</small>	
DATE: 5/4/2016	
SEAL 	
DOCUMENT NOT CONSIDERED FINAL UNLESS ALL SIGNATURES COMPLETED	

CURB RAMP LOCATIONS:

- | | |
|------------------------------|------------------------------|
| ① -Y6- STA 20+47+/-, 22' LT | ⑧ -Y5- STA 15+35+/-, 31' LT |
| ② -Y6- STA 20+49+/-, 25' RT | ⑨ -Y6- STA 28+64+/-, 32' LT |
| ③ -Y6A- STA 10+37+/-, 23' LT | ⑩ -Y6- STA 28+65+/-, 22' RT |
| ④ -Y6- STA 21+32+/-, 22' LT | ⑪ -Y6- STA 29+57+/-, 39' LT |
| ⑤ -Y6- STA 21+35+/-, 28' RT | ⑫ -Y6- STA 29+56+/-, 22' RT |
| ⑥ -Y6A- STA 10+43+/-, 37' LT | ⑬ -Y6A- STA 11+50+/-, 25' RT |
| ⑦ -Y5- STA 15+26+/-, 33' RT | ⑭ -Y6A- STA 11+94+/-, 24' RT |

NOTE: PLACE CROSSWALK LINES 4' TO RIGHT AND LEFT OF CENTER OF CURB RAMP

*NOTE: PLACE HIGH INTENSITY CROSSWALK LINES TO THE CENTER OF CURB RAMPS

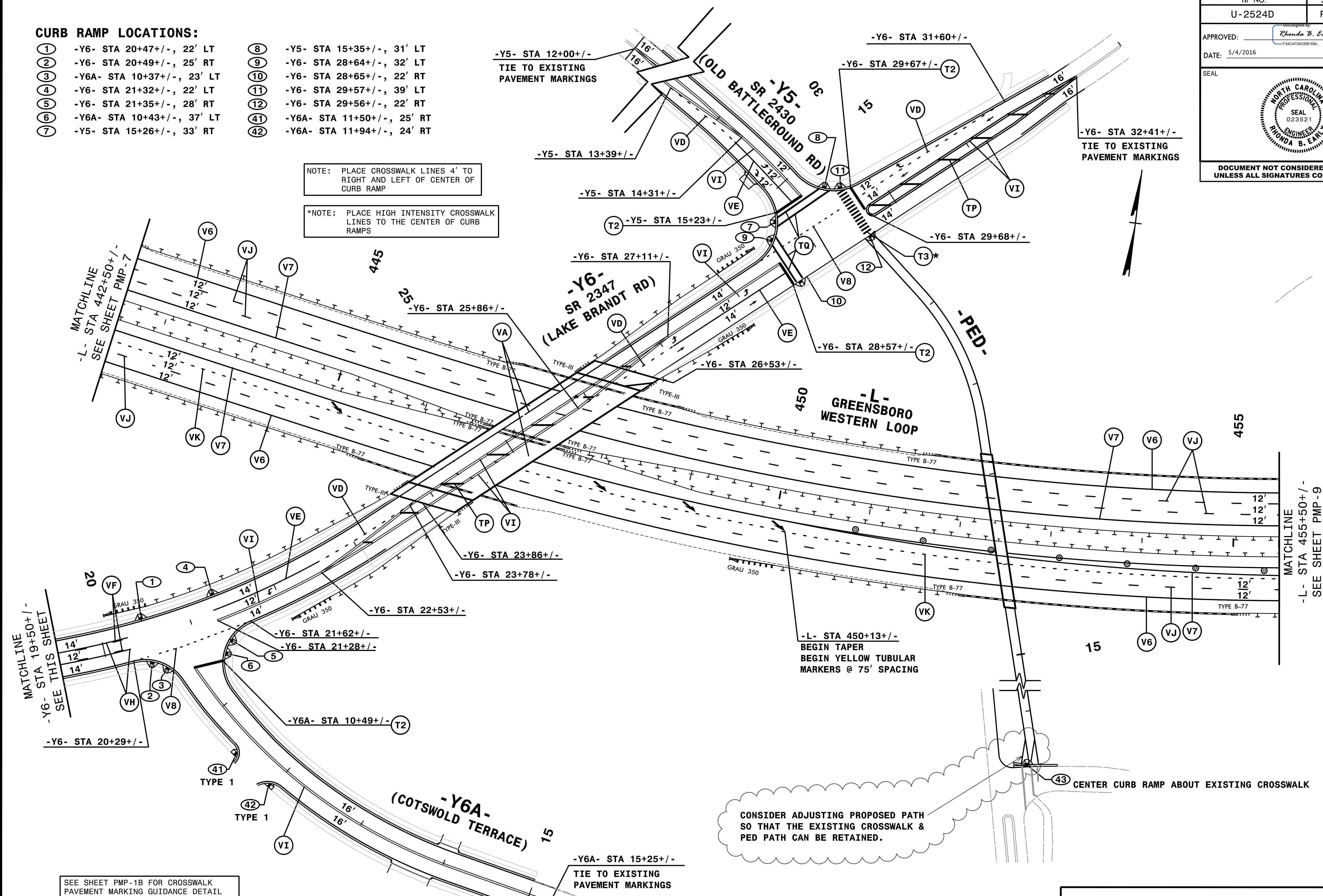

SEE SHEET PMP-1B FOR CROSSWALK PAVEMENT MARKING GUIDANCE DETAIL

CONSIDER ADJUSTING PROPOSED PATH SO THAT THE EXISTING CROSSWALK & PED PATH CAN BE RETAINED.

⑬ CENTER CURB RAMP ABOUT EXISTING CROSSWALK

2:45:51 PM
\\PMP\U2524D_PMP_PMP08.dgn
\$\$\$\$\$USERNAME\$\$\$\$\$

HNTB HNTB NORTH CAROLINA, P.C.
343 E. SIX FORKS ROAD, SUITE 200
RALEIGH, NORTH CAROLINA 27609
NC LICENSE NO: C-1554

PAVEMENT MARKING DETAIL

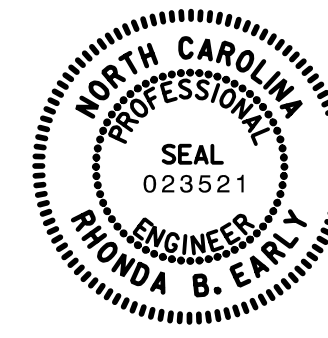
TIP NO. U-2524D	SHEET NO. PMP-9
APPROVED: <i>Rhonda B. Early</i> <small>PROFESSIONAL ENGINEER 13407 SAC08148A</small>	
DATE: 5/4/2016	
SEAL	
	
DOCUMENT NOT CONSIDERED FINAL UNLESS ALL SIGNATURES COMPLETED	

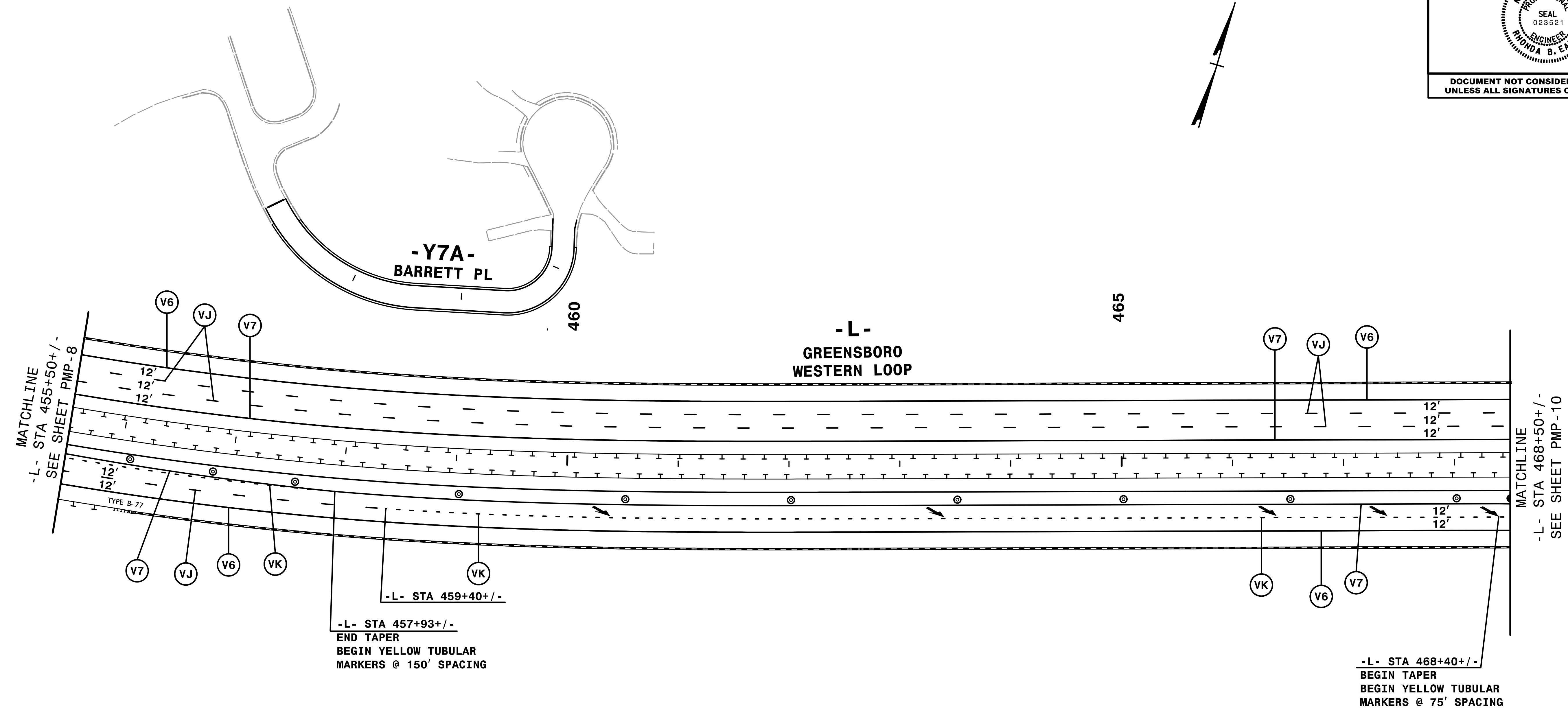

2:45:57 PM
\\PMP\U2524D_PMP_PMP09.dgn
\$\$\$\$\$USERNAME\$\$\$\$\$

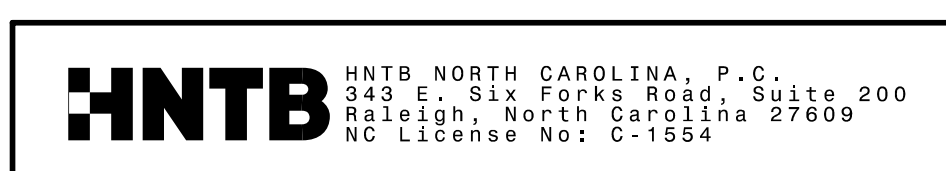

PAVEMENT MARKING DETAIL

TIP NO. U-2524D	SHEET NO. PMP-10
APPROVED: <i>Rhonda B. Early</i> <small>Downloaded by: Rhonda B. Early F34CAFAC8BF48A...</small>	
DATE: 5/4/2016	
SEAL	
	
DOCUMENT NOT CONSIDERED FINAL UNLESS ALL SIGNATURES COMPLETED	

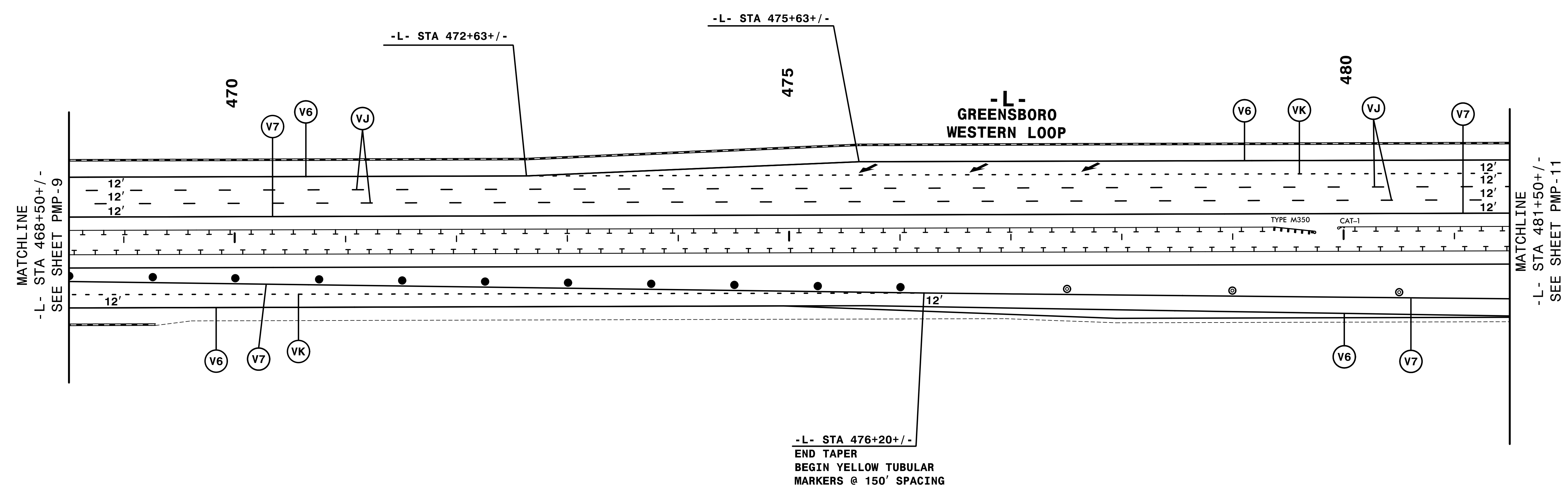
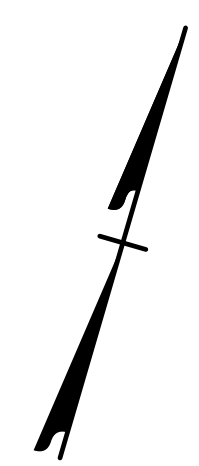

2:46:02 PM
\\PMP\U2524D_PMP_PMP10.dgn
\$\$\$\$\$USERNAME\$\$\$\$\$

HNTB HNTB NORTH CAROLINA, P.C.
343 E. SIX FORKS ROAD, SUITE 200
RALEIGH, NORTH CAROLINA 27609
NC License No: C-1554

PAVEMENT MARKING DETAIL

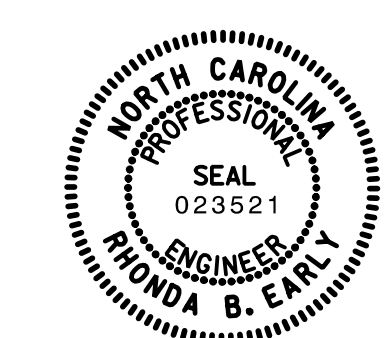
TIP NO. U-2524D	SHEET NO. PMP-11
APPROVED: <i>Rhonda B. Early</i> F34CAF5AC8BF4BA...	
DATE: 5/4/2016	
SEAL	
	
DOCUMENT NOT CONSIDERED FINAL UNLESS ALL SIGNATURES COMPLETED	

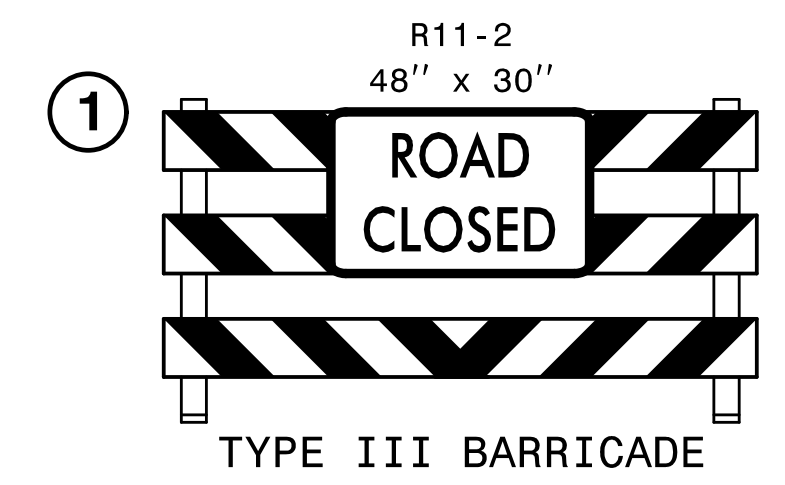

TYPE III BARRICADE
SIGN AND BARRICADE TO REMAIN IN
PLACE UPON COMPLETION OF PROJECT
(SEE SPECIAL PROVISIONS)

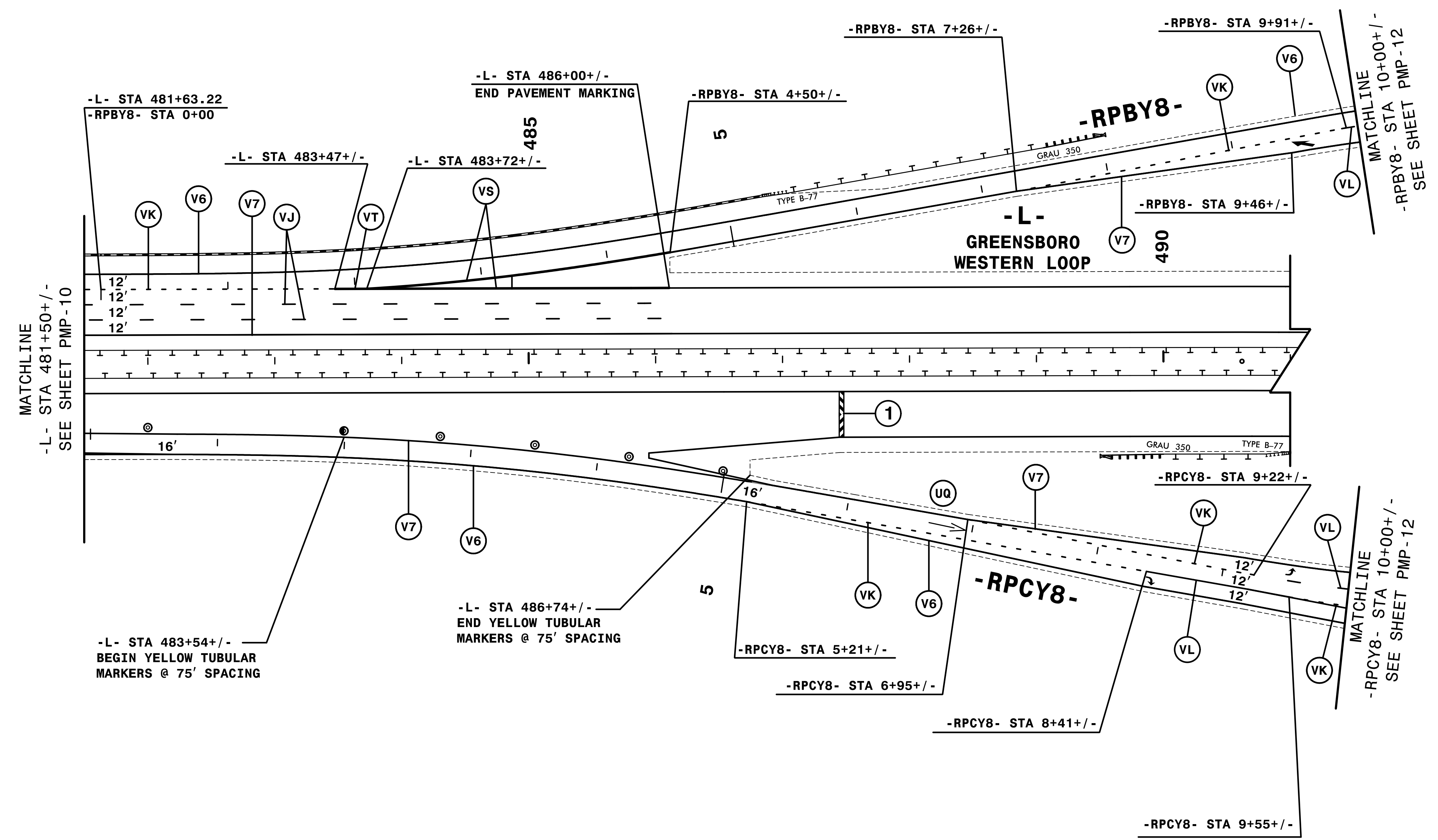
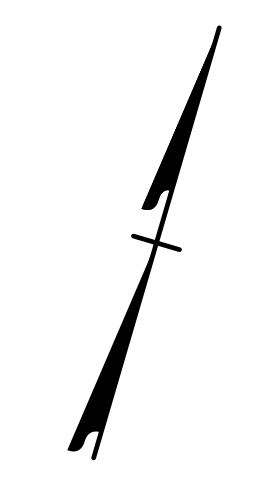

2:46:08 PM
\\PMP\U2524D_PMP_PMP1.dgn
\$\$\$\$\$USERNAME\$\$\$\$\$

HNTB HNTB NORTH CAROLINA, P.C.
343 E. SIX FORKS ROAD, SUITE 200
RALEIGH, NORTH CAROLINA 27609
NC License No: C-1554

PAVEMENT MARKING DETAIL

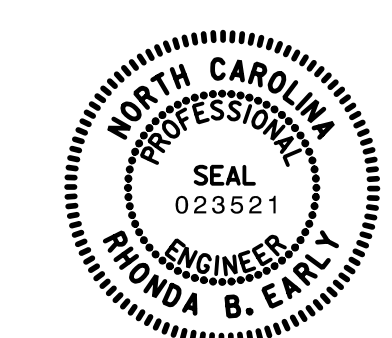
TIP NO. U-2524D	SHEET NO. PMP-12
APPROVED: <i>Rhonda B. Early</i> F54CAF3AC8BF48A	
DATE: 5/4/2016	
SEAL 	
DOCUMENT NOT CONSIDERED FINAL UNLESS ALL SIGNATURES COMPLETED	

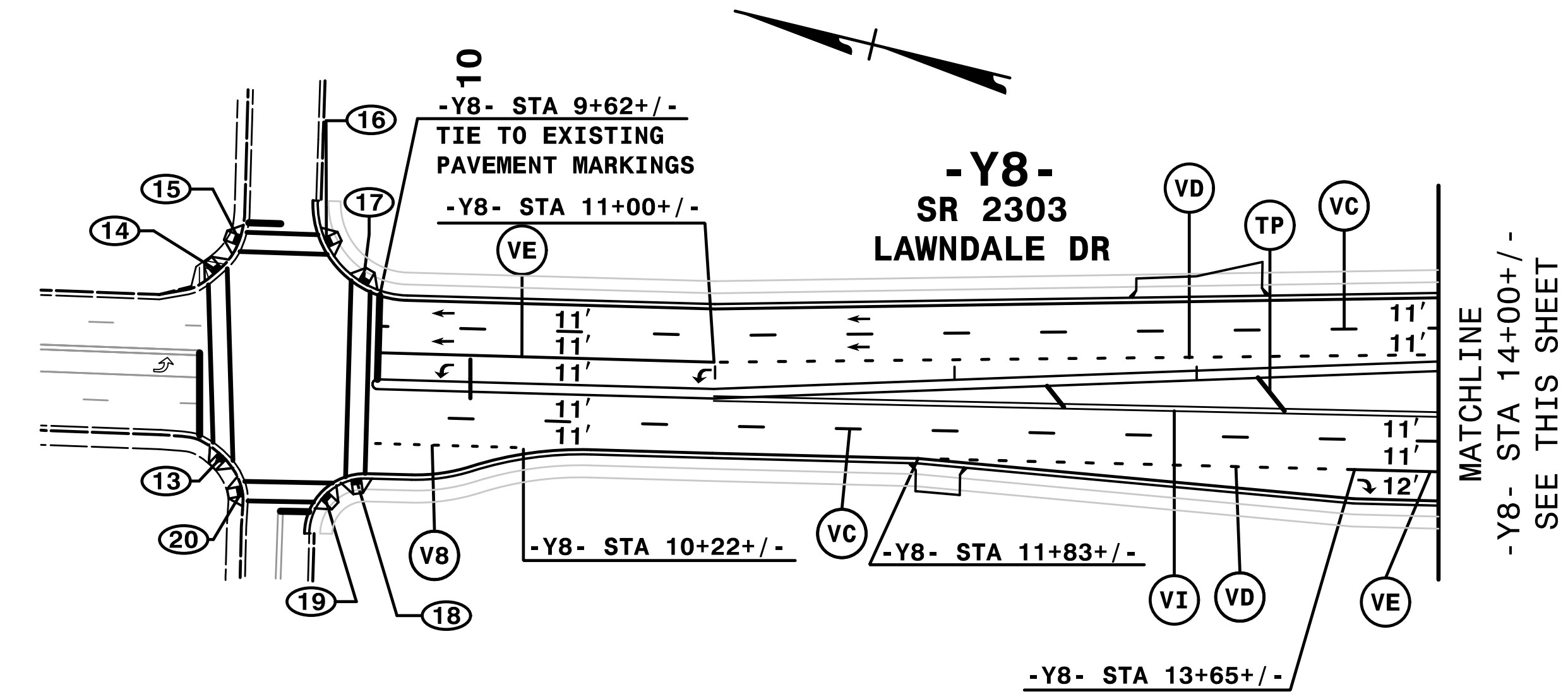

CURB RAMP LOCATIONS

13 -Y8- STA 13+98+/-, 32' RT	27 -SPDY8- STA 2+93+/-, 8' RT
14 -Y8- STA 13+96+/-, 45' LT	28 -SPDY8- STA 2+93+/-, 14' LT
15 -Y8- STA 14+05+/-, 57' LT	29 -Y8- STA 24+24+/-, 61' LT
16 -Y8- STA 14+40+/-, 56' LT	30 -Y8- STA 24+55+/-, 65' LT
17 -Y8- STA 14+56+/-, 40' LT	31 -Y8- STA 25+35+/-, 38' RT
18 -Y8- STA 14+53+/-, 41' RT	32 -Y8- STA 24+63+/-, 42' RT
19 -Y8- STA 14+40+/-, 48' RT	33 -SPCY8- STA 3+78+/-, 23' RT
20 -Y8- STA 14+06+/-, 46' RT	34 -SPCY8- STA 3+94+/-, 14' LT
22 -SPAY8- STA 4+45+/-, 21' RT	35 -RPCY8- STA 13+28+/-, 16' RT
22 -SPAY8- STA 4+45+/-, 8' LT	36 -RPCY8- STA 13+26+/-, 16' LT
23 -RPAY8- STA 14+05+/-, 16' RT	37 -RPBY8- STA 13+32+/-, 16' RT
24 -RPAY8- STA 14+05+/-, 16' LT	38 -RPBY8- STA 13+35+/-, 16' LT
25 -RPDY8- STA 13+95+/-, 16' RT	39 -SPBY8- STA 3+17+/-, 8' RT
26 -RPDY8- STA 13+95+/-, 16' LT	40 -SPBY8- STA 3+16+/-, 14' LT

NOTE: CENTER CROSSWALKS BASED ON CURB RAMP LOCATIONS

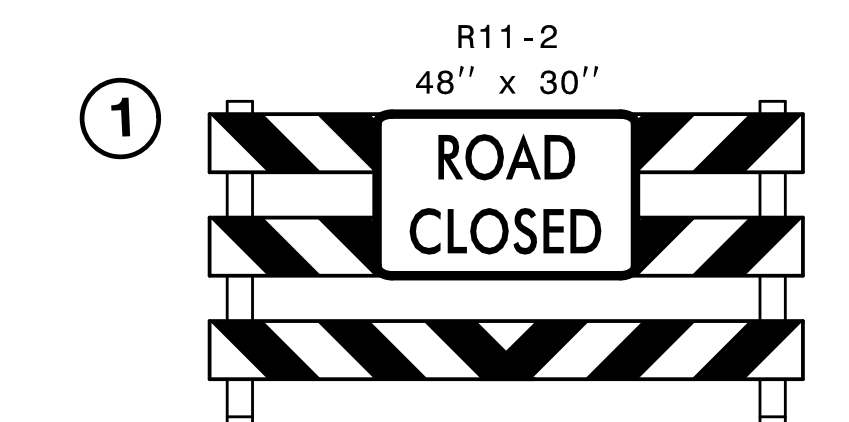
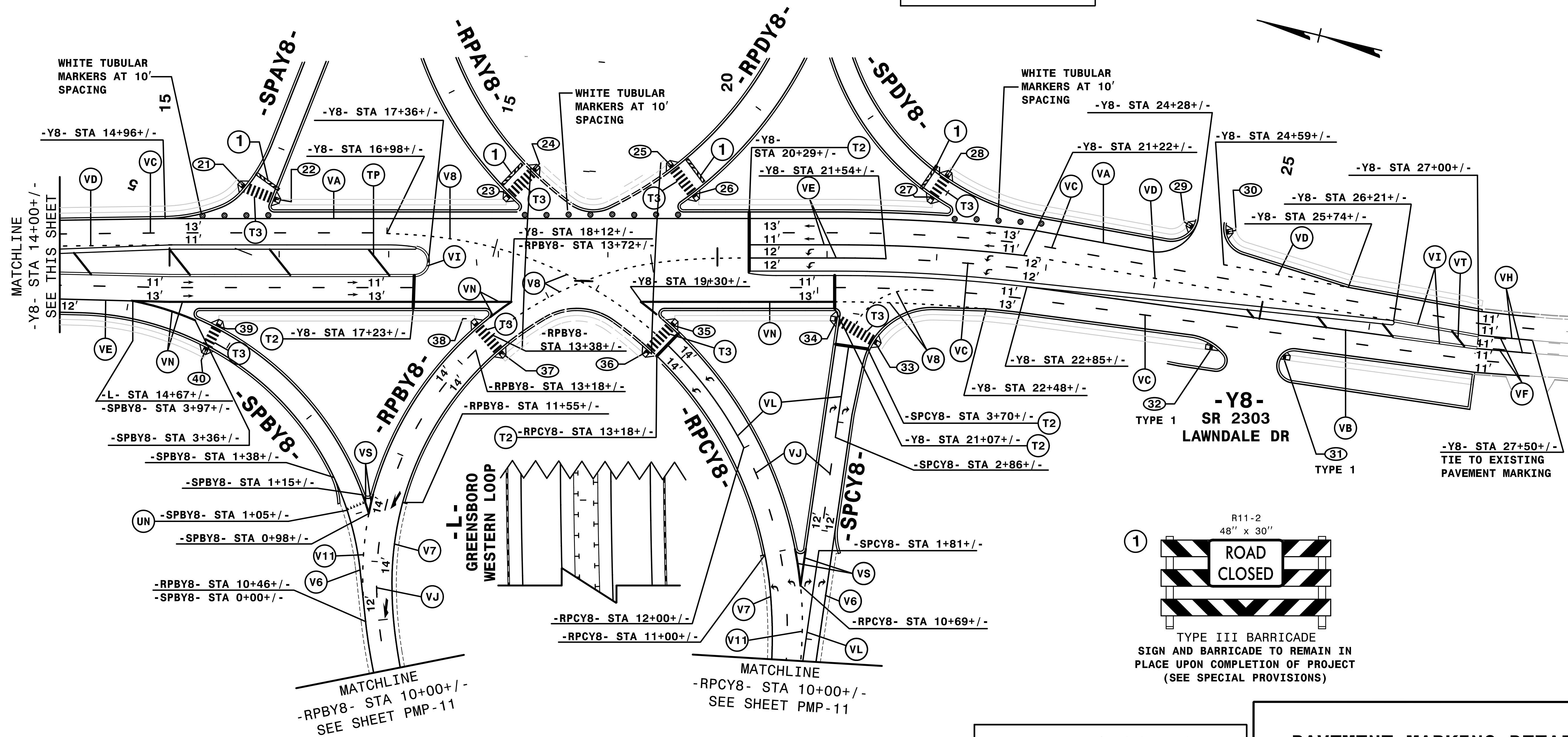

TYPE III BARRICADE SIGN AND BARRICADE TO REMAIN IN PLACE UPON COMPLETION OF PROJECT (SEE SPECIAL PROVISIONS)

2:46:14 PM
\\PMP\U2524D_PMP_PMP12.dgn
\$\$\$\$\$USERNAME\$\$\$\$\$