

SECTION THRU FENCE

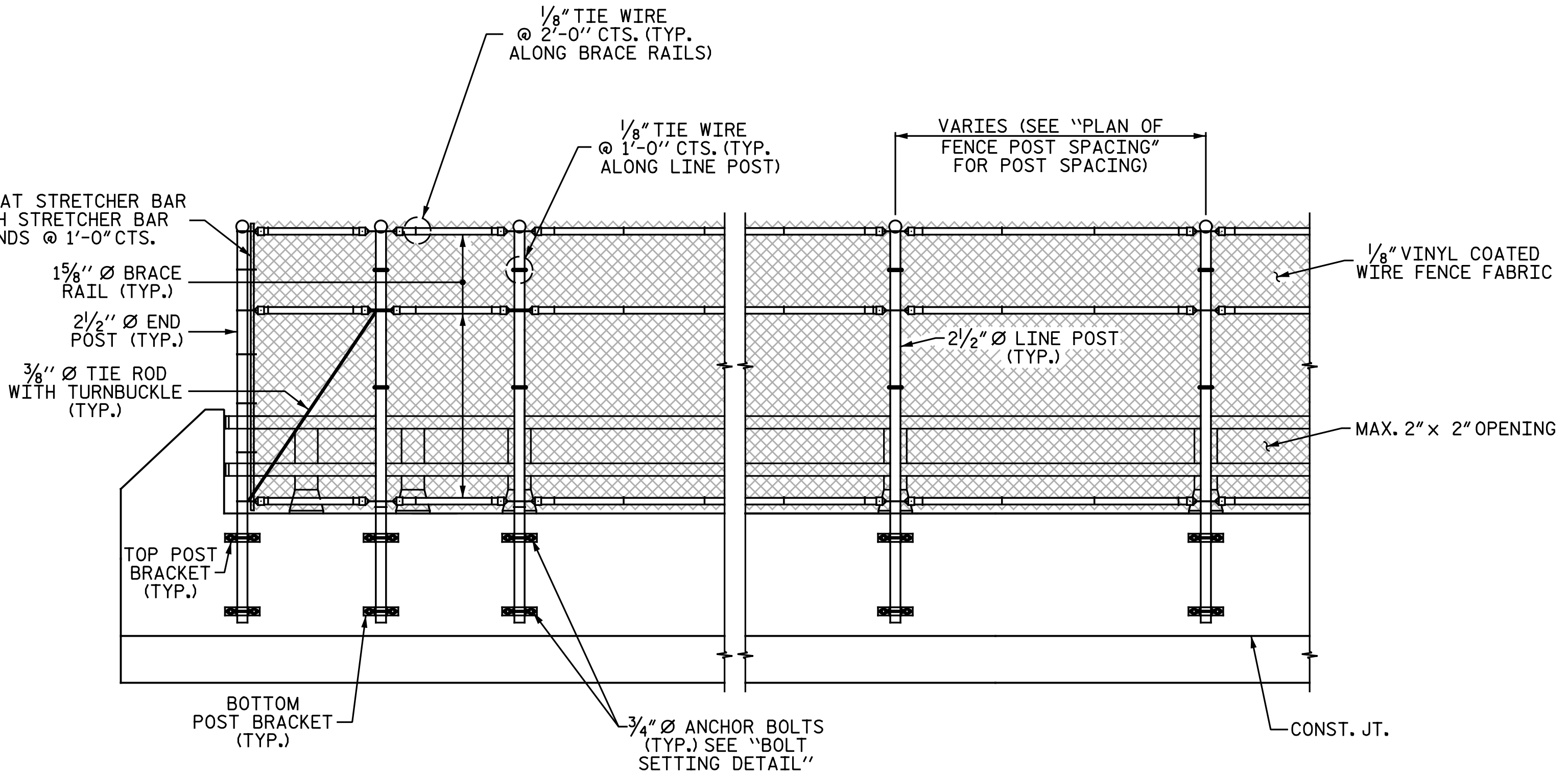

PARTIAL ELEVATION

NOTES:

FOR 79" VINYL COATED CHAIN LINK FENCE, SEE SPECIAL PROVISIONS.

BOLTS SHALL CONFORM TO THE REQUIREMENTS OF ASTM A307 AND NUTS SHALL CONFORM TO THE REQUIREMENTS OF AASHTO M291. BOLTS, NUTS AND WASHERS SHALL BE GALVANIZED. (AT THE CONTRACTOR'S OPTION, STAINLESS STEEL BOLTS, NUTS, AND WASHERS MAY BE USED AS AN ALTERNATIVE FOR THE 3/4" DIAMETER GALVANIZED BOLTS, NUTS, AND WASHERS. THEY SHALL CONFORM TO OR EXCEED THE MECHANICAL REQUIREMENTS OF ASTM A307. THE USE OF THIS ALTERNATE SHALL BE APPROVED BY THE ENGINEER.)

FOR SETTING ANCHOR BOLTS, THE CONTRACTOR SHALL USE AN ADHESIVE BONDING SYSTEM. LEVEL ONE FIELD TESTING OF BONDING SYSTEM IS REQUIRED AND THE YIELD LOAD OF THE 3/4" DIAMETER BOLTS IS 12 KIPS.

ALL FENCE MATERIAL SHALL MEET THE REQUIREMENTS OF SECTION 1050 OF THE STANDARD SPECIFICATIONS. GALVANIZE ALL STEEL PARTS AND HARDWARE IN ACCORDANCE WITH ARTICLE 1076 OF THE STANDARD SPECIFICATIONS.

FENCE POST LOCATIONS SHALL BE SHIFTED, AS NECESSARY, TO MAINTAIN 12" MINIMUM DISTANCE FROM ANCHOR BOLT TO JOINTS IN CONCRETE PARAPET.

DIMENSIONS ARE TAKEN ALONG OUTSIDE FACE OF CONCRETE PARAPET.

FABRICATOR IS RESPONSIBLE FOR DESIGN OF MISCELLANEOUS VINYL COATED CHAIN LINK HARDWARE

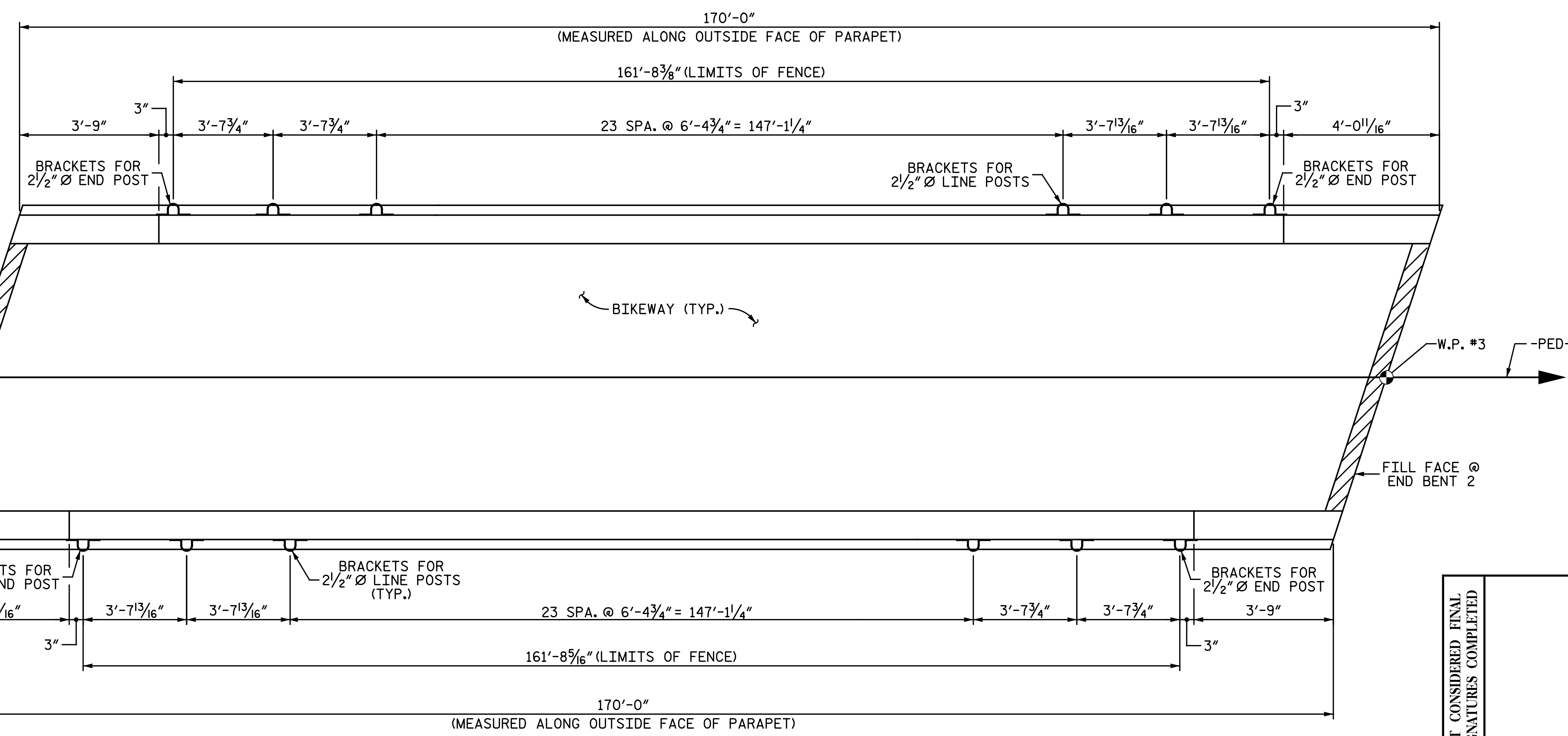

PLAN OF FENCE POST SPACING

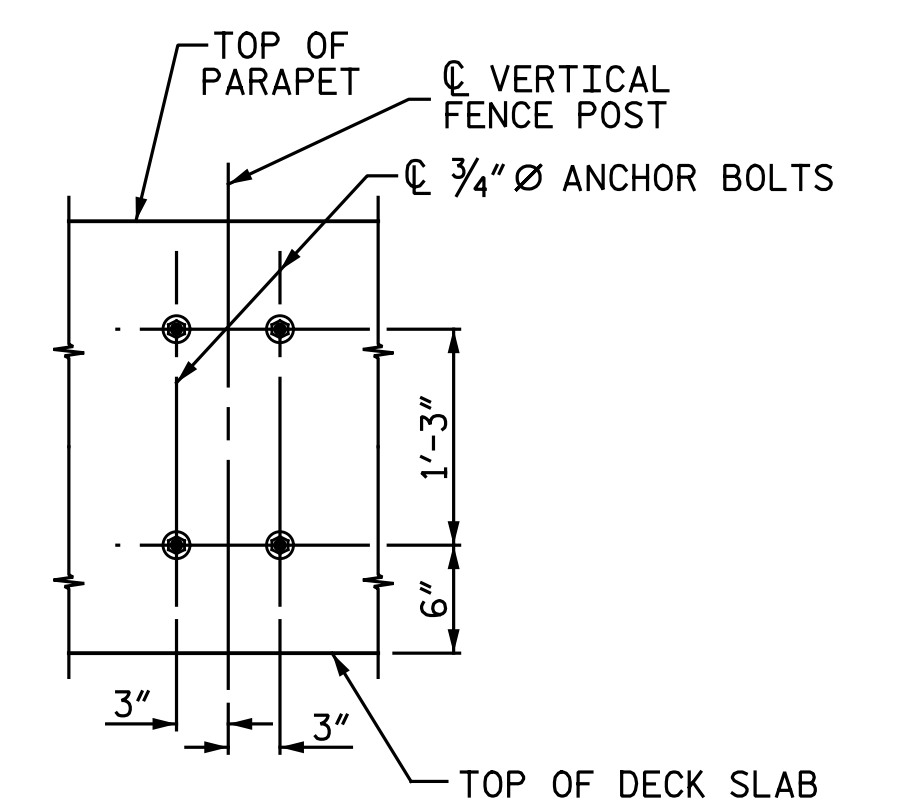

BOLT SETTING DETAIL

PROJECT NO. U-2524D
GUILFORD COUNTY
 STATION: 13+62.84 -PED-

5/5/2016 12:03:25 PM
 File Name: Y:\Projects\NC DOT\U-2524D\Site\1.DWG\Final\402_024_U2524D_SML.CL.dgn
 User: Y:\Projects\NC DOT\U-2524D\Site\1.DWG\Final\402_024_U2524D_SML.CL.dgn

DRAWN BY: J.N.A./N.B.S. DATE: 11-16-15
 CHECKED BY: A.M. HOUSTON DATE: 2-9-16

PAY LENGTH = 323.39 LIN. FT.

DOCUMENT NOT CONSIDERED FINAL
 UNLESS ALL SIGNATURES COMPLETED

Documented by:
Bradley J. Bell
 C41A38FCAC3A34...
 5/5/2016

Michael Baker
 INTERNATIONAL
 Michael Baker Engineering
 8000 Regency Parkway, Suite 600
 Cary, North Carolina 27518
 NC License No.: F-1084

STATE OF NORTH CAROLINA DEPARTMENT OF TRANSPORTATION RALEIGH					
SUPERSTRUCTURE					
BRIDGE MOUNTED VINYL COATED CHAIN LINK FENCE					
REVISIONS					
NO.	BY:	DATE:	NO.	BY:	DATE:
1			3		
2			4		
					SHEET NO. S2-23
					TOTAL SHEETS 33