

TIP NO. U-2524D	SHEET NO. SIGN-2C
APPROVED: <i>Ronald W. King</i> 13E7A7FB8AA4448	
DATE: 5/4/2016	
SEAL	
	
DOCUMENT NOT CONSIDERED FINAL UNLESS ALL SIGNATURES COMPLETED	

STATE OF NORTH CAROLINA
DEPT. OF TRANSPORTATION
DIVISION OF HIGHWAYS
RALEIGH, N.C.

1-12

ENGLISH STANDARD DRAWING FOR
MILEPOST AND PLACEMENT

SHEET 1 OF 1
904D40

MILEPOST PLACEMENT

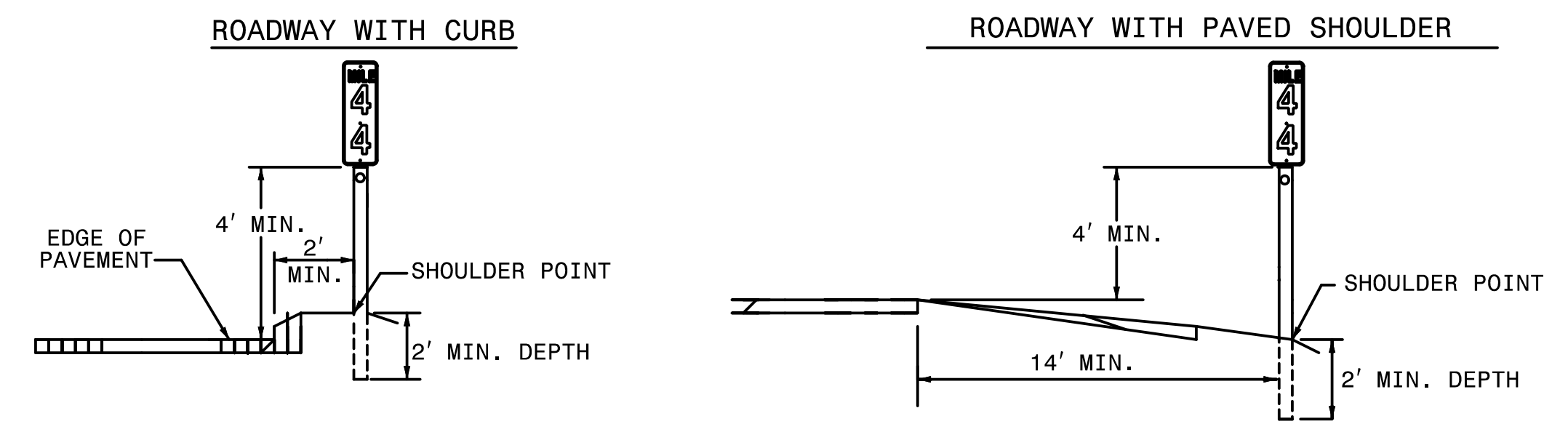

NOTES:

- A MILEPOST SIGN SHALL CONSIST OF ONE (1) 12" X 24", 12" X 36" OR 12" X 48" SIGN PANEL. AN ENHANCED REFERENCE LOCATION SIGN SHALL CONSIST OF ONE (1) 18" X 54" SIGN PANEL. AN INTERMEDIATE ENHANCED REFERENCE LOCATION SIGN SHALL CONSIST OF ONE (1) 18" X 60" SIGN PANEL.
- FABRICATE SIGNS FROM .080" SHEET ALUMINUM. EACH SIGN SHALL HAVE WHITE STUCK-ON MESSAGE AND BORDER ON GREEN BACKGROUND. MESSAGE, BORDER AND BACKGROUND TO BE REFLECTORIZED.
- MILEPOST LOCATION SIGNS REQUIRE ONE (1) 2-LB GALVANIZED STEEL U-CHANNEL POST AND ENHANCED REFERENCE LOCATION SIGNS REQUIRE ONE (1) 3-LB GALVANIZED STEEL U-CHANNEL POST. THE POST'S LENGTH MUST MEET THE REQUIREMENTS SHOWN IN THESE STANDARDS.
- POSTS SHALL BE DRIVEN. THE TOP OF POST SHALL NOT PROJECT ABOVE THE TOP OF SIGN.
- ATTACH EACH SIGN TO THE WIDE FACE (FLANGES) OF THE POST BY MEANS OF THE FOLLOWING COMBINATION- 5/16" HEX HEAD BOLT, NYLON WASHER, SHIM, FLAT WASHER, LOCK WASHER, HEX NUT. FULL CONTACT BETWEEN THE SIGN AND THE POST SHALL BE ACHIEVED. NO BUCKLING OF THE SIGN WILL BE PERMITTED.
- PLACE MILEPOST SIGNS AT THE SHOULDER POINT UNLESS THE ENGINEER DIRECTS OTHERWISE.

POST DETAILS

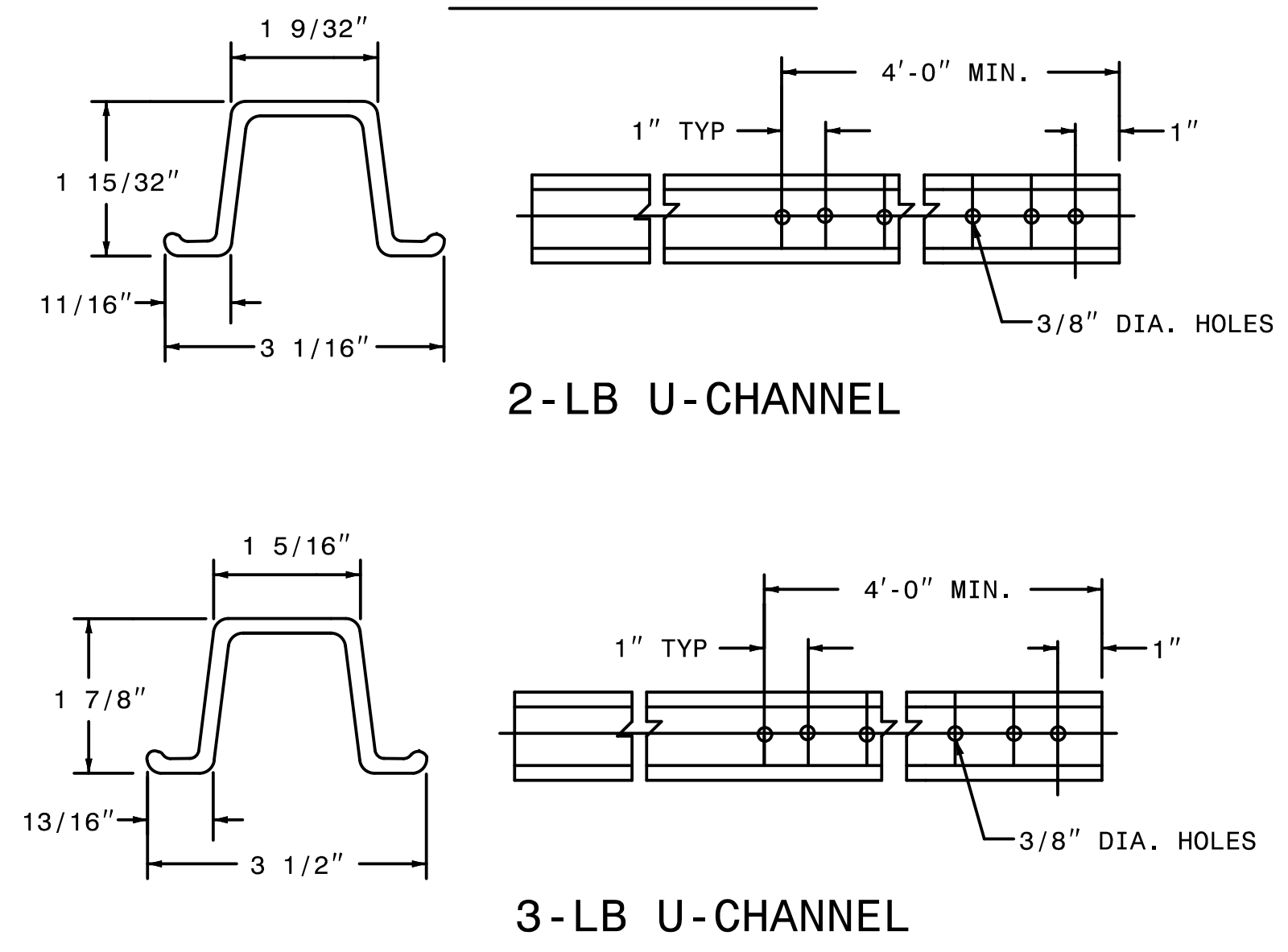

FASTENER

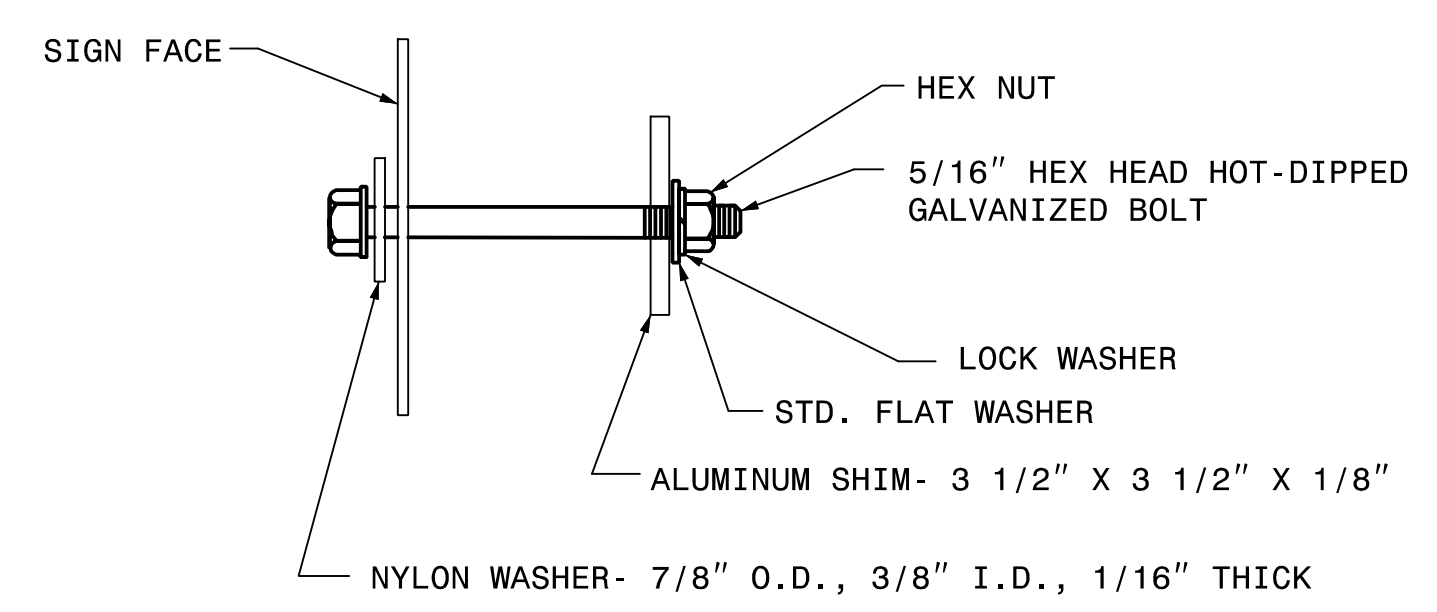

STATE OF NORTH CAROLINA
DEPT. OF TRANSPORTATION
DIVISION OF HIGHWAYS
RALEIGH, N.C.

1-12

ENGLISH STANDARD DRAWING FOR
MILEPOST AND PLACEMENT

SHEET 1 OF 1
904D40