

FROM -L- STA. 426+50 TO STA. 427+70 LT

FROM -L- STA. 423+50 TO STA. 426+00 RT

-L- STA. 434+28 LT

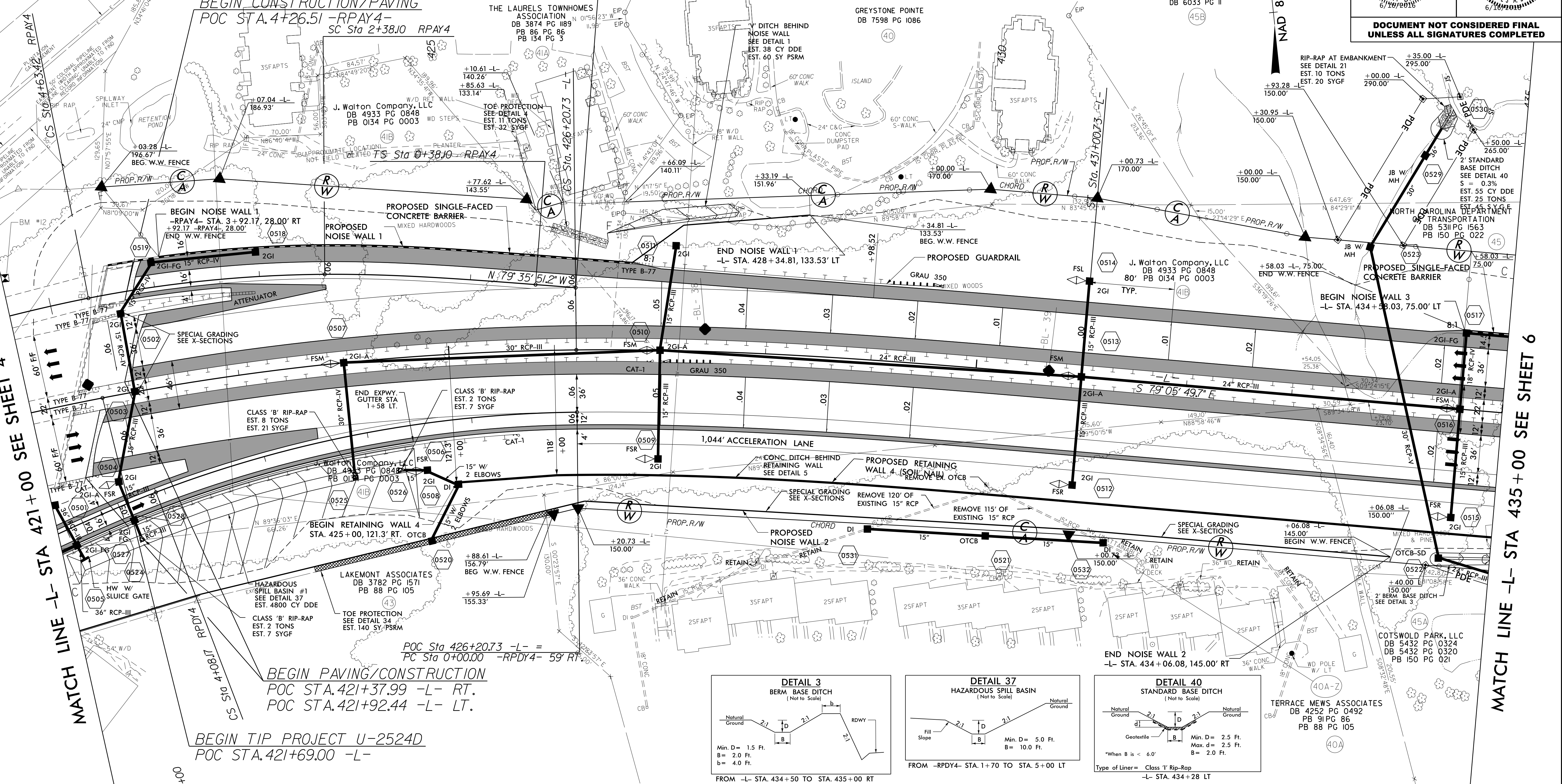

MATCH LINE -L- STA 421+00 SEE SHEET 4

MATCH LINE -L- STA 435+00 SEE SHEET 6

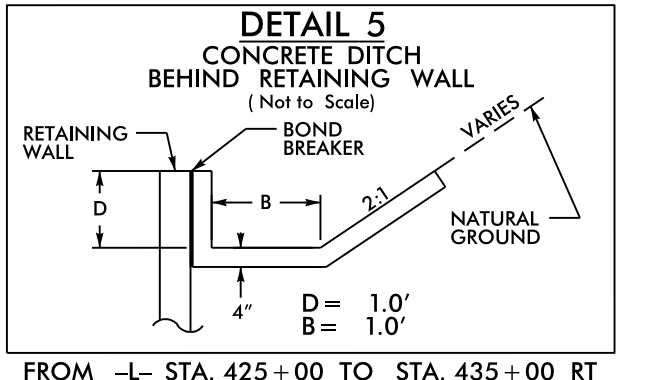
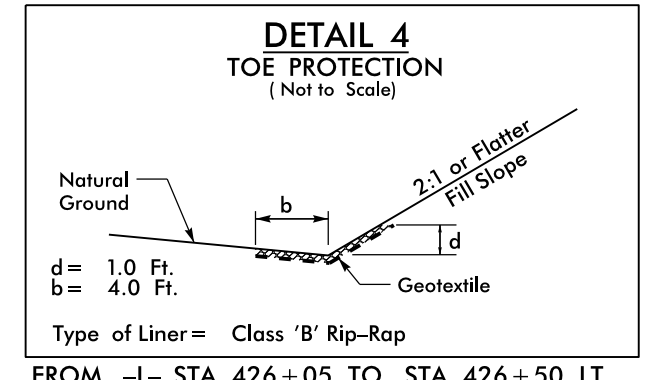
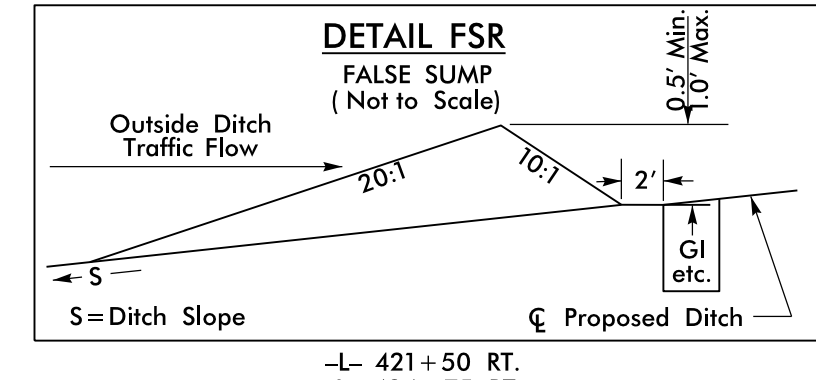
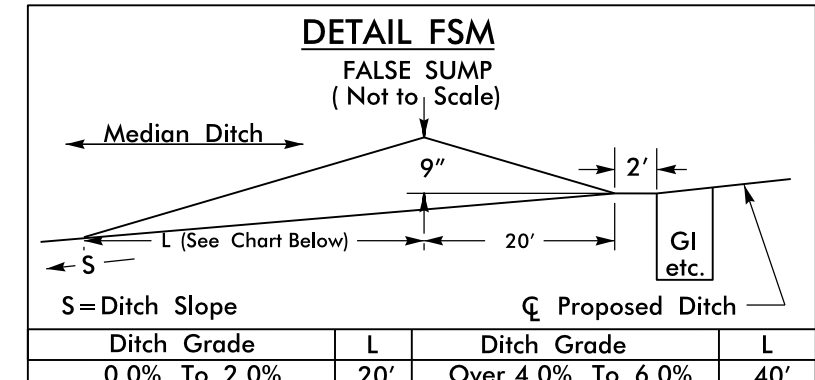
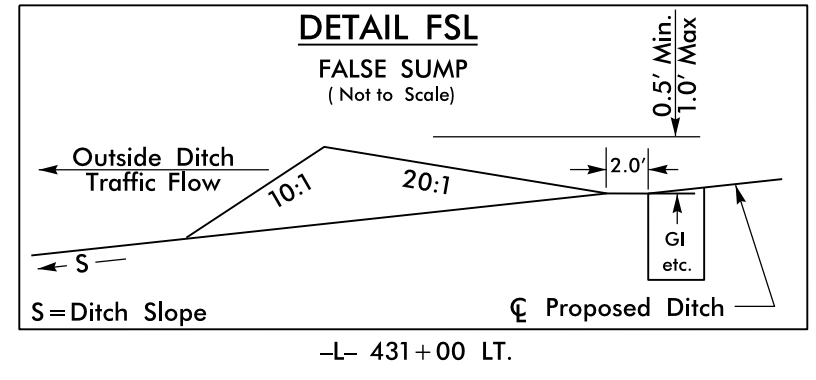
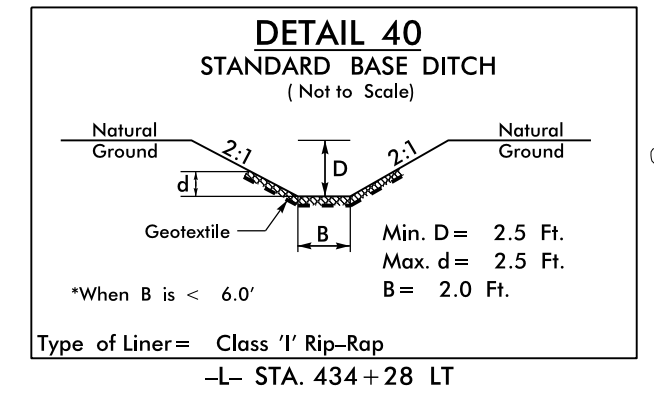
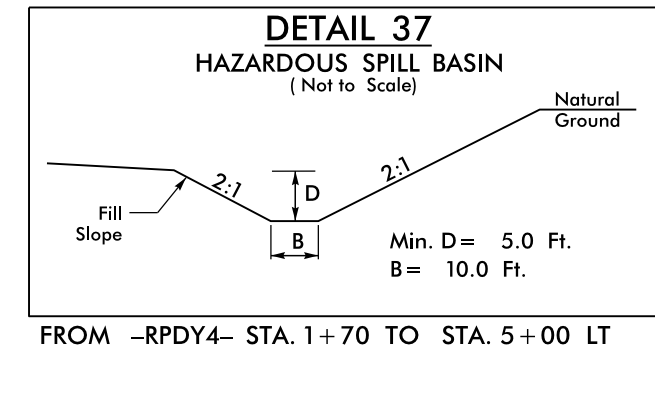
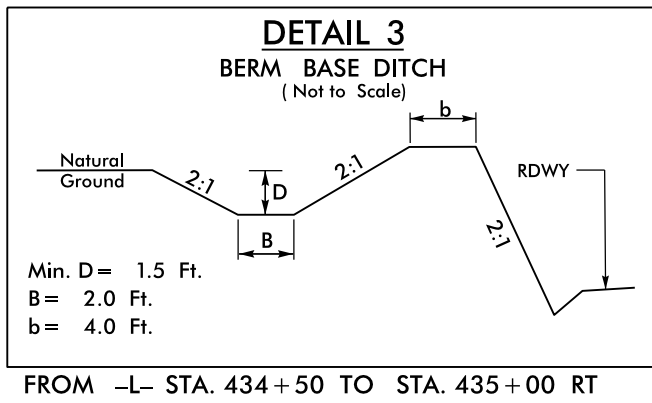

NOTE: SEE SHEET 2B-2 FOR CURVE DATA SEE SHEET 15 & 16 FOR -L- PROFILE SEE SHEET 23 FOR RPY4 PROFILE SEE SHEET 23 FOR RPDY4 PROFILE

24-MAY-2016 2:55:21 PM C:\Users\jg\OneDrive\Projects\U2524D\RDY_PSH_05.dgn