

| | |
|--------------------------------|--------------------|
| TIP NO. B-4490 | SHEET NO. PMP-4 |
| APPROVED: <i>Ayman Alqudwa</i> | |
| DATE: 9/1/2015 | |

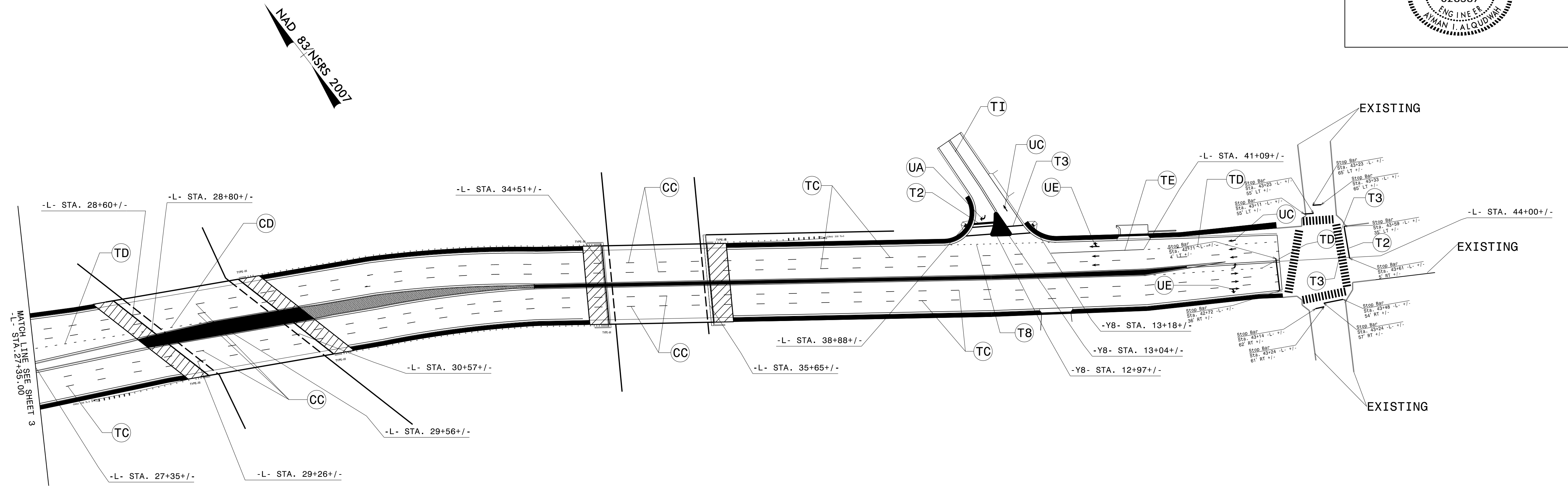

PAVEMENT MARKING DETAIL

8/31/2015
 C:\Users\bnw\Documents\CADD\Projects\44430.pmp_907.dgn
 User:bnw