

**This electronic collection of documents is provided  
for the convenience of the user  
and is Not a Certified Document –**

**The documents contained herein were originally issued  
and sealed by the individuals whose names and license  
numbers appear on each page, on the dates appearing  
with their signature on that page.**

**This file or an individual page  
shall not be considered a certified document.**

**CONTRACT NO: C203789 T.I.P.: B-4929**

**STATE OF NORTH CAROLINA  
DEPARTMENT OF TRANSPORTATION**

**PAVEMENT MARKING PLAN**

**PENDER COUNTY**

**LOCATION: ROLAND AVENUE  
N. TOPSAIL DRIVE  
N. NEW RIVER DRIVE**

<b>TIP NO.</b> B - 4929	<b>SHEET NO.</b> PMP - 1
APPROVED: <u>William J. Hamilton</u> <small>00550070404844</small>	
DATE: 5/27/2016	
	
<b>DOCUMENT NOT CONSIDERED FINAL UNLESS ALL SIGNATURES COMPLETED</b>	

**INDEX**

SHEET NO.	DESCRIPTION
PMP-1	PAVEMENT MARKING PLAN COVER SHEET AND PAVEMENT MARKING SCHEDULE
PMP-1A	CROSSWALK AND STOP BAR PAVEMENT MARKING DETAIL
PMP-2	CURB RAMP LOCATION AND SYMBOL LEGEND
PMP-3 THRU 8	PAVEMENT MARKING DETAILS

**ROADWAY STANDARD DRAWING**

THE FOLLOWING ROADWAY STANDARDS AS APPEAR IN "ROADWAY STANDARD DRAWINGS" - PROJECT SERVICES UNIT - N.C. DEPARTMENT OF TRANSPORTATION - RALEIGH, N.C., DATED JANUARY 2012 ARE APPLICABLE TO THIS PROJECT AND BY REFERENCE HEREBY ARE CONSIDERED A PART OF THESE PLANS:

STD. NO.	TITLE
1205.01	PAVEMENT MARKINGS - LINE TYPES AND OFFSETS
1205.02	PAVEMENT MARKINGS - TWO-LANE AND MULTILANE ROADWAYS
1205.04	PAVEMENT MARKINGS - INTERSECTIONS
1205.05	PAVEMENT MARKINGS - TURN LANES
1205.08	PAVEMENT MARKINGS - SYMBOLS AND WORD MESSAGES
1205.09	PAVEMENT MARKINGS - PAINTED ISLANDS
1250.01	RAISED PAVEMENT MARKERS - INSTALLATION SPACING
1251.01	RAISED PAVEMENT MARKERS - PERMANENT AND TEMPORARY

**GENERAL NOTES**

THE FOLLOWING GENERAL NOTES APPLY AT ALL TIMES FOR THE DURATION OF THE CONSTRUCTION PROJECT, EXCEPT WHEN OTHERWISE NOTED IN THE PLAN, OR DIRECTED BY THE ENGINEER.

- A) INSTALL PAVEMENT MARKINGS AND PAVEMENT MARKERS ON THE FINAL SURFACE AS FOLLOWS:

ROAD NAME	MARKING	MARKER
ASPHALT SURFACE	THERMOPLASTIC	RAISED MARKERS
CONCRETE SURFACE	POLYUREA WITH HIGHLY REFLECTIVE ELEMENTS	RAISED MARKERS

- B) TIE PROPOSED PAVEMENT MARKING LINES TO EXISTING PAVEMENT MARKING LINES.  
 C) REMOVE/REPLACE ANY CONFLICTING/DAMAGED PAVEMENT MARKINGS AND MARKERS.  
 D) STOP BAR LOCATION AT NON-SIGNALIZED INTERSECTIONS MAY BE ADJUSTED AS DIRECTED BY THE ENGINEER.  
 E) UNLESS OTHERWISE SPECIFIED, HEATED-IN-PLACE THERMOPLASTIC MAY BE USED IN LIEU OF COLD APPLIED PLASTIC FOR STOP BARS, SYMBOLS, CHARACTERS AND DIAGONALS ON ASPHALT OR CONCRETE ROADWAYS. IF HEATED-IN-PLACE IS USED, IT SHALL BE PAID FOR USING THE COLD APPLIED PAY ITEM.  
 F) TYPE III COLD APPLIED PLASTIC MAY BE USED IN LIEU OF TYPE II COLD APPLIED PLASTIC. IF TYPE III COLD APPLIED PLASTIC IS USED, IT SHALL BE PAID FOR USING THE TYPE II COLD APPLIED PLASTIC PAY ITEM.

**PAVEMENT MARKING SCHEDULE**

SYMBOL	DESCRIPTION
<b>THERMOPLASTIC(4", 90 MILS)</b>	
TA	WHITE EDGE LINE
TB	YELLOW EDGE LINE
<b>THERMOPLASTIC(4", 120 MILS)</b>	
TD	3 FT. - 9 FT./SP WHITE MINISKIP
TE	WHITE SOLID LANE LINE
TF	10FT. YELLOW SKIP
TH	YELLOW SINGLE CENTER
TI	YELLOW DOUBLE CENTER
T8	2 FT. - 6 FT./SP WHITE MINISKIP
T9	2 FT. - 6 FT./SP YELLOW MINISKIP
<b>THERMOPLASTIC(8", 90 MILS)</b>	
TN	WHITE GORE LINE
TO	WHITE DIAGONAL
TP	YELLOW DIAGONAL
<b>THERMOPLASTIC(8", 120 MILS)</b>	
TQ	WHITE CROSSWALK LINE
<b>THERMOPLASTIC(12", 120 MILS)</b>	
T10	3 FT. - 3 FT./SP WHITE MINISKIP
<b>THERMOPLASTIC(24", 120 MILS)</b>	
T2	WHITE STOPBAR
T3	WHITE CROSSWALK LINE
<b>THERMOPLASTIC PAVEMENT MARKING SYMBOLS (90 MILS)</b>	
UA	LEFT TURN ARROW
UB	RIGHT TURN ARROW
UC	STRAIGHT ARROW
UE	COMBO. RIGHT/STRAIGHT ARROW
UF	COMBO. LEFT/RIGHT ARROW
UN	24" YIELD LINE TRIANGLE
<b>POLYUREA (4")</b>	
VA	WHITE EDGE LINE
VD	3 FT. - 9 FT./SP WHITE MINISKIP
VE	WHITE SOLID LANE LINE
VI	YELLOW DOUBLE CENTER
<b>POLYUREA (8")</b>	
VN	WHITE GORE LINE
<b>COLD APPLIED PLASTIC (TYPE II)</b>	
-	MARKING SYMBOL

**PLAN REVIEWED BY: N.C.D.O.T. SIGNING AND DELINEATION UNIT**

AYMAN ALQUDWAH, P.E. SIGNING & DELINEATION REGIONAL ENGINEER

MITCH EATON SIGNING & DELINEATION PROJECT DESIGN ENGINEER

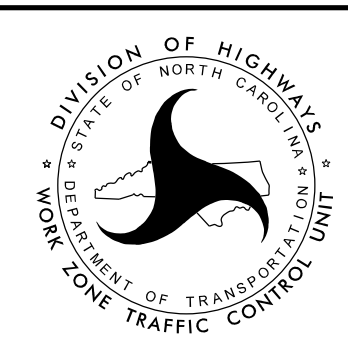

**PLAN PREPARED BY: Ramey Kemp & Associates**

W. JASON HAMILTON, P.E., PTOE PROJECT MANAGER

TIMOTHY S. POPELKA, EI PROJECT ENGINEER



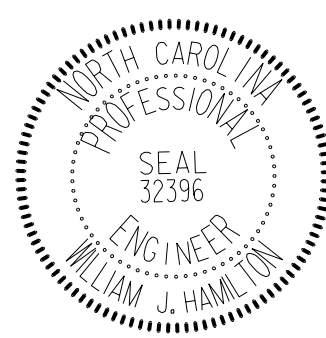

TIP NO. B - 4929	SHEET NO. PMP - 1A
Approved by: <i>William J. Hamilton</i> DATE: 3/24/2015	
SEAL 	

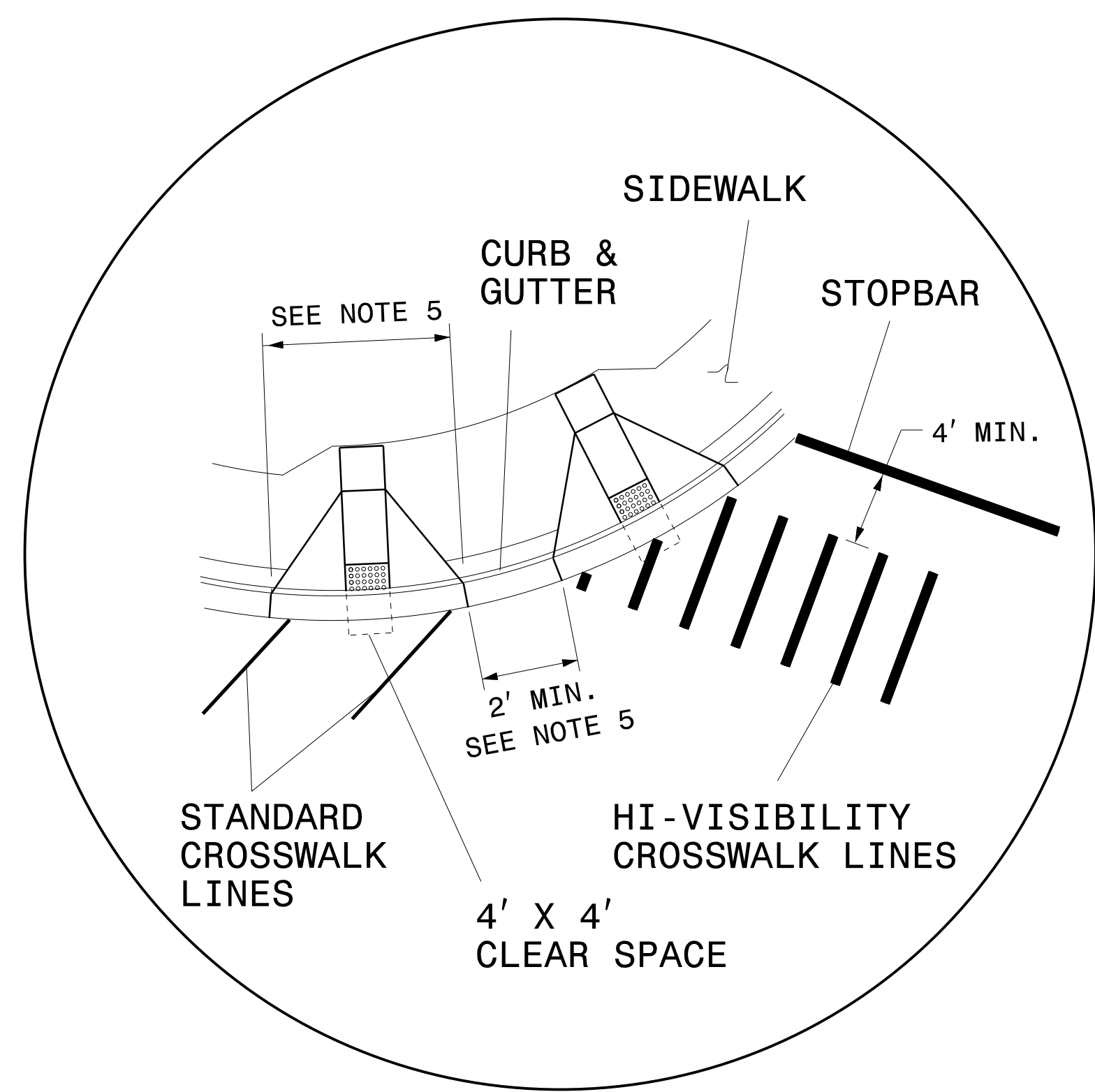
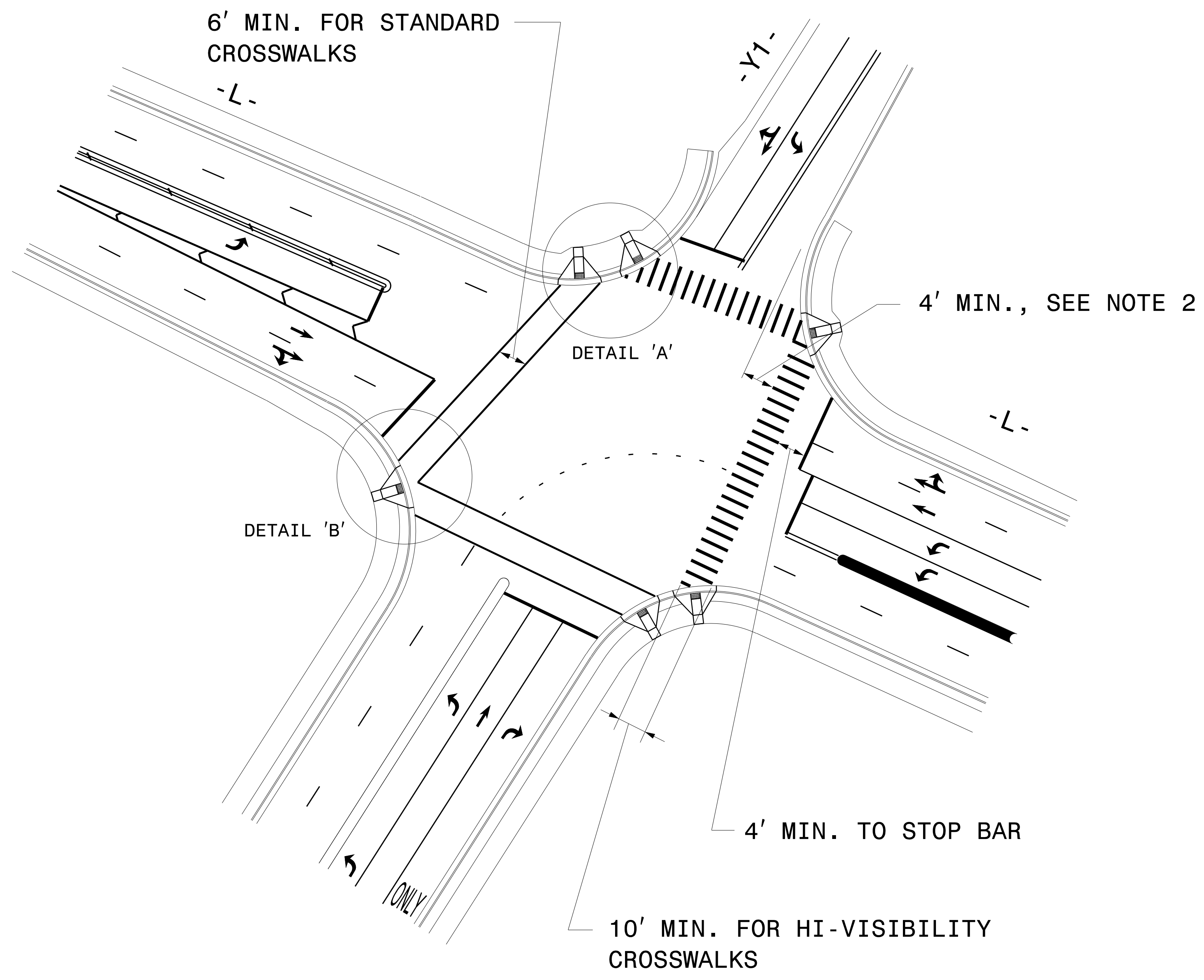

DETAIL 'A'- DUAL CURB RAMPS

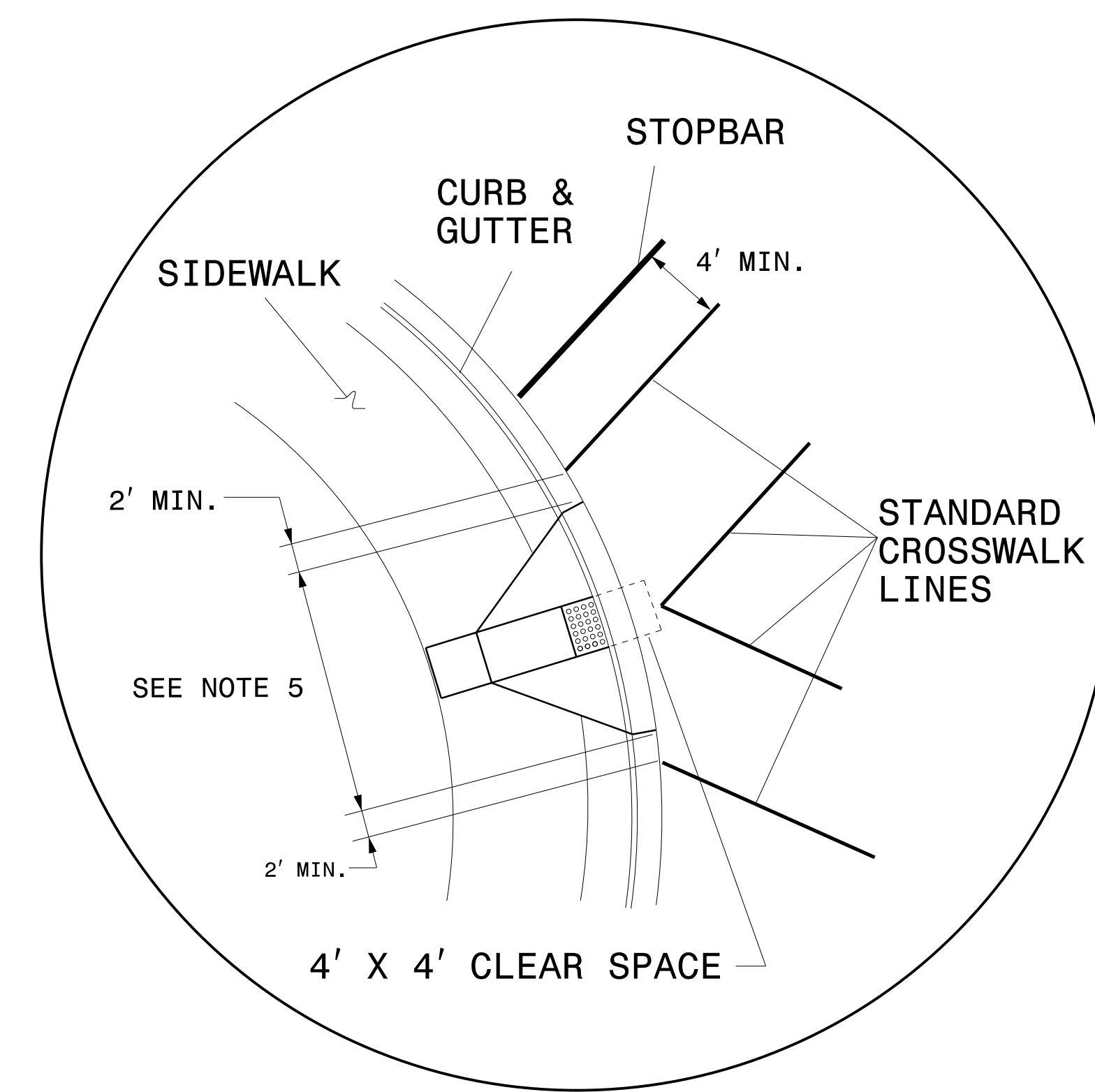

DETAIL 'B'- SINGLE DIAGONAL CURB RAMP

### GUIDANCE DETAIL FOR STANDARD AND HI-VISIBILITY CROSSWALKS AT SIGNALIZED OR STOP SIGN CONTROLLED INTERSECTIONS

NOTES:

1. USE DETAILS ABOVE AND THE FOLLOWING NOTES FOR GUIDANCE IN PLACING CROSSWALKS AND STOP BARS NOT STATIONED ON THE DETAIL SHEETS OR WHEN FIELD ADJUSTMENTS REQUIRED MOVING STATIONED MARKINGS AS DIRECTED BY THE ENGINEER. REFER TO NCDOT ROADWAY STANDARD DRAWINGS, MUTCD AND ADA STANDARDS FOR ADDITIONAL GUIDANCE.
2. SET BACK DISTANCE FROM INSIDE CROSSWALK MARKING TO NEAREST EDGE OF TRAVEL IS 4' MIN.
3. BEYOND THE BOTTOM GRADE BRAKE, A CLEAR SPACE OF 4' X 4' MINIMUM SHALL BE PROVIDED WITHIN THE WIDTH OF THE CROSSWALK.
4. SINGLE DIAGONAL CURB RAMPS WITH FLARED SIDES SHALL HAVE A SEGMENT OF CURB 2 FEET LONG MINIMUM LOCATED ON EACH SIDE OF THE CURB RAMP AND WITHIN THE MARKED CROSSING, SEE DETAIL 'B'.
5. CURB RAMPS SHALL BE CONSTRUCTED IN ACCORDANCE TO THE LATEST NCDOT ROADWAY STANDARD DRAWINGS.

**CROSSWALK AND STOP BAR PAVEMENT MARKING DETAIL**

TIP NO.	SHEET NO.
B-4929	PMP-2
APPROVED: <u>William J. Hamilton</u>	
DATE: 4/25/2016	
SEAL	
	
<b>DOCUMENT NOT CONSIDERED FINAL UNLESS ALL SIGNATURES COMPLETED</b>	



<b>CURB RAMP LOCATIONS AND STYLES</b> (CENTERLINE OF RAMP AT FACE OF CURB)		
1	-L1- 14+40 +/-	STANDARD
2	-L1- 14+58 +/-	STANDARD
3	-L1- 15+01 +/-	STANDARD
4	-L1- 15+01 +/-	STANDARD
5	-Y2- 10+89 +/-	STANDARD
6	-Y2- 10+89 +/-	STANDARD
7	-L2- 16+96 +/-	STANDARD
8	-L2- 16+96 +/-	STANDARD
9	-Y1- 10+89 +/-	STANDARD
10	-Y1- 10+89 +/-	STANDARD
11	-Y1- 17+22 +/-	STANDARD
12	-Y1- 17+22 +/-	STANDARD
13	-Y4- 12+71 +/-	STANDARD
14	-Y4- 12+80 +/-	TYPE 1
15	-L2- 57+94 +/-	STANDARD
16	-L2- 58+17 +/-	STANDARD
17	-Y3- 15+03 +/-	STANDARD
18	-Y1- 50+73 +/-	TYPE 1
19	-Y1- 49+12 +/-	STANDARD
20	-Y1- 49+12 +/-	STANDARD
21	-Y3- 11+69 +/-	STANDARD
22	-Y3- 11+69 +/-	STANDARD
23	-Y1- 47+72 +/-	STANDARD
24	-Y1- 47+72 +/-	STANDARD

<b>CURB RAMP LOCATIONS AND STYLES</b> (CENTERLINE OF RAMP AT FACE OF CURB)		
25	-Y1- 35+73 +/-	STANDARD
26	-Y1A- 14+36 +/-	STANDARD
27	-L1- 15+01 +/-	CONCRETE ISLAND RAMP
28	-L1- 15+01 +/-	CONCRETE ISLAND RAMP
29	-Y2- 10+89 +/-	CONCRETE ISLAND RAMP
30	-Y2- 10+89 +/-	CONCRETE ISLAND RAMP
31	-L2- 16+96 +/-	CONCRETE ISLAND RAMP
32	-L2- 16+96 +/-	CONCRETE ISLAND RAMP
33	-Y1- 10+89 +/-	CONCRETE ISLAND RAMP
34	-Y1- 10+89 +/-	CONCRETE ISLAND RAMP
35	-Y1- 17+22 +/-	CONCRETE ISLAND RAMP
36	-Y1- 17+22 +/-	CONCRETE ISLAND RAMP
37	-L2- 57+94 +/-	CONCRETE ISLAND RAMP
38	-L2- 57+94 +/-	CONCRETE ISLAND RAMP
39	-SL2- 10+73 +/-	CONCRETE ISLAND RAMP
40	-SL2- 10+73 +/-	CONCRETE ISLAND RAMP
41	-SL1- 11+23 +/-	CONCRETE ISLAND RAMP
42	-SL1- 11+23 +/-	CONCRETE ISLAND RAMP
43	-Y3- 15+03 +/-	CONCRETE ISLAND RAMP
44	-Y3- 15+03 +/-	CONCRETE ISLAND RAMP
45	-Y3- 15+03 +/-	CONCRETE ISLAND RAMP
46	-Y3- 11+69 +/-	CONCRETE ISLAND RAMP
47	-Y3- 11+69 +/-	CONCRETE ISLAND RAMP

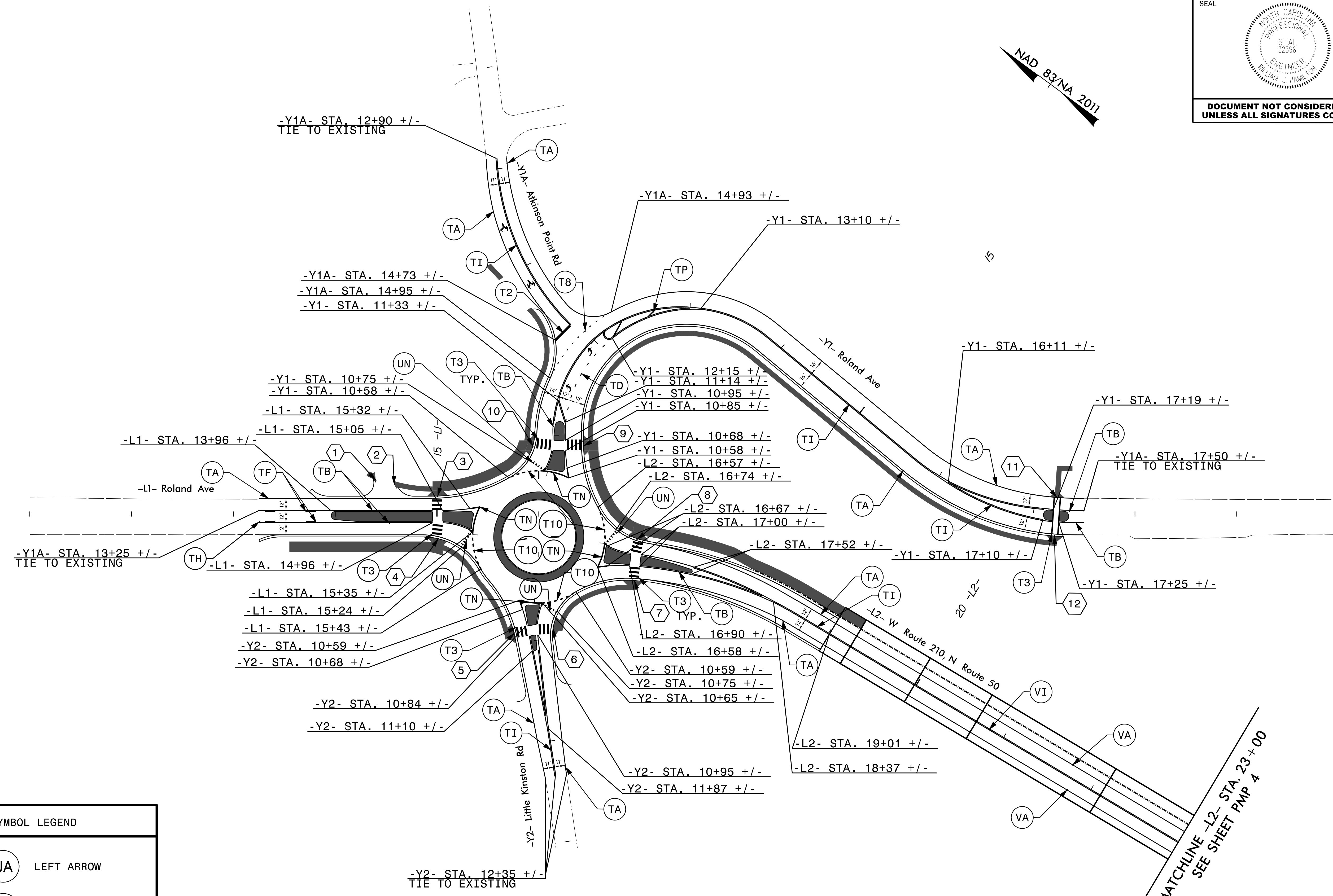

TIP NO. B-4929	SHEET NO. PMP-3
APPROVED: <i>William J. Hamilton</i> 3/24/2016	
DATE: _____	
SEAL 	
DOCUMENT NOT CONSIDERED FINAL UNLESS ALL SIGNATURES COMPLETED	

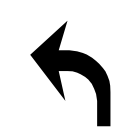

SYMBOL LEGEND	
	UA LEFT ARROW
	UF COMB. LEFT/RIGHT ARROW

Prepared in the offices of:



**RAMEY KEMP & ASSOCIATES, INC.**  
 Transportation Engineers  
 5808 Farrington Place, Suite 100  
 Raleigh, North Carolina 27609  
 919-872-5115 Tel. 919-878-5416 Fax.  
 www.rameykemp.com

**PAVEMENT MARKING DETAIL**

8/17/99

TIP NO. B - 4929	SHEET NO. PMP - 4
APPROVED: <i>William J. Hamilton</i> 3/24/2016	
DATE: 3/24/2016	
SEAL 	
DOCUMENT NOT CONSIDERED FINAL UNLESS ALL SIGNATURES COMPLETED	

NAD 83/NA 2011

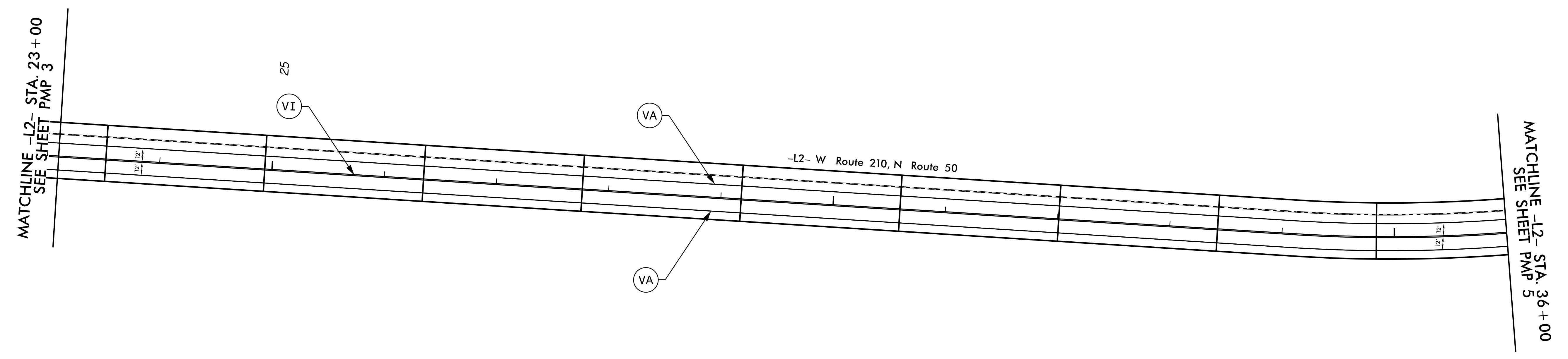

30

35

3/24/2016  
B-4929\_pmp04.dgn  
jmartinez

Prepared in the offices of:



**RAMEY KEMP  
&  
ASSOCIATES, INC.**  
TRANSPORTATION ENGINEERS  
2005 Farrington Place, Suite 100  
Raleigh, North Carolina 27609  
919-875-5115 Tel. 919-875-5415 Fax  
www.rameykemp.com

# PAVEMENT MARKING DETAIL

8/17/09

TIP NO. B-4929	SHEET NO. PMP-5
APPROVED: <u>William J. Hamilton</u> 3/24/2016	
DATE: _____	
SEAL 	
<b>DOCUMENT NOT CONSIDERED FINAL UNLESS ALL SIGNATURES COMPLETED</b>	

NAD 83/NA 2011

05

45

40

25

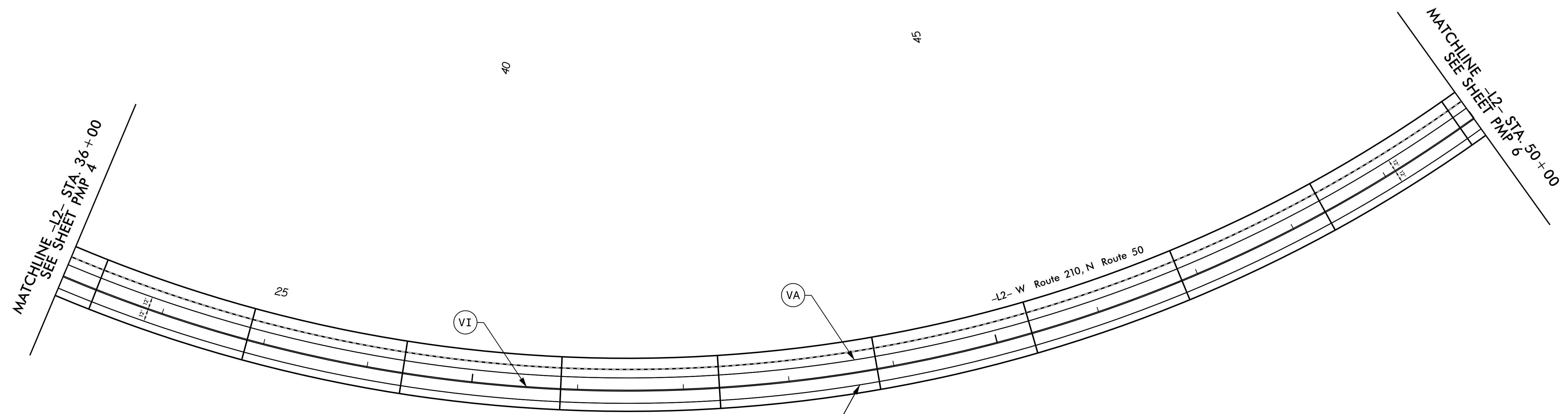

3/24/2016 10:43:26 pmp05.dgn  
\\fs1\pmp05.dgn

Prepared in the offices of:



**RAMEY KEMP ASSOCIATES, INC.**  
TRANSPORTATION ENGINEERS  
8808 Farrington Place, Suite 100  
Raleigh, North Carolina 27609  
919-875-5115 TEL 919-875-5410 FAX  
www.rameykemp.com

# PAVEMENT MARKING DETAIL



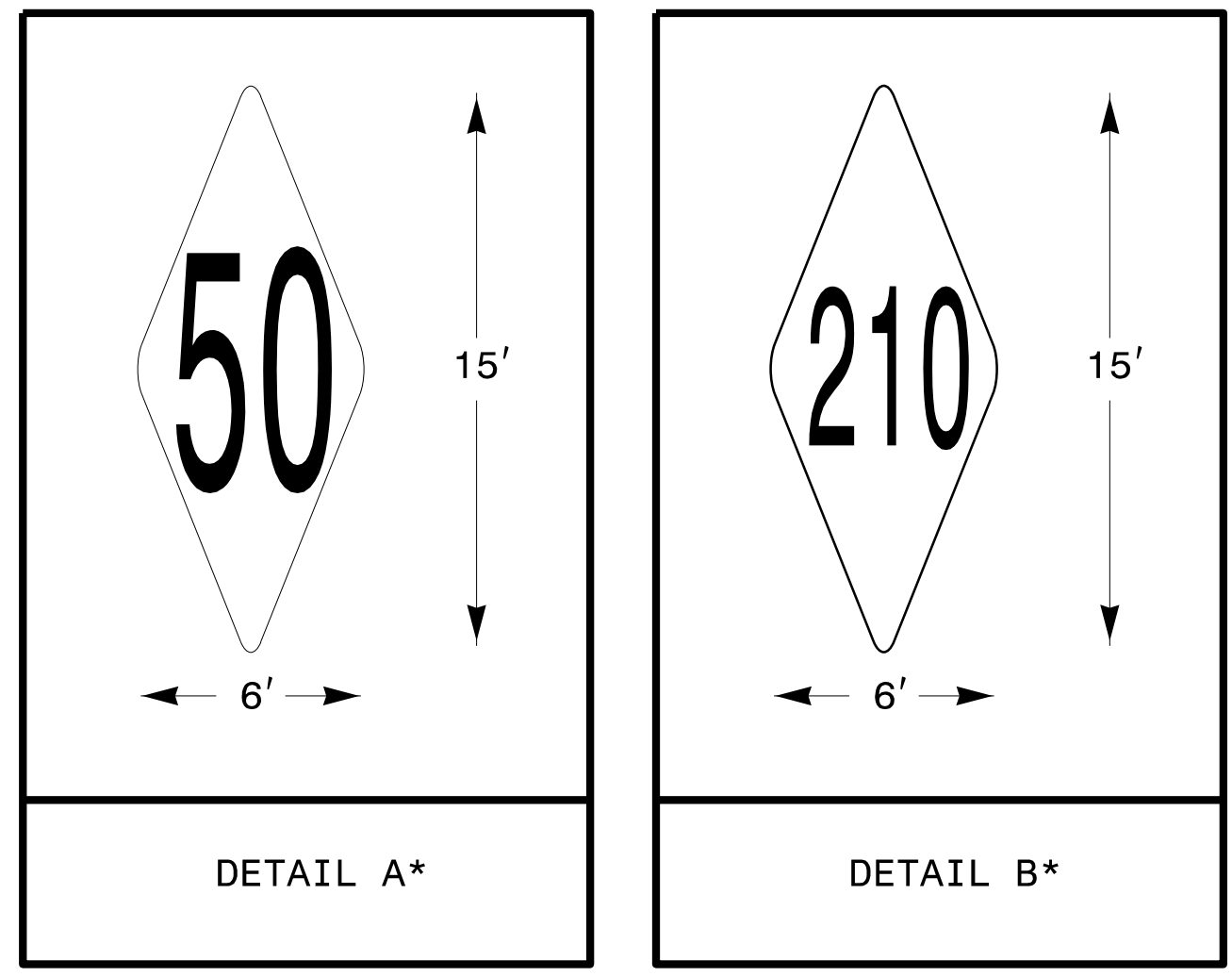

\*USE COLD APPLIED PLASTIC FOR ROUTE SHIELDS ON CONCRETE SURFACE

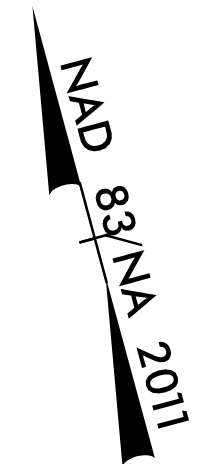

TIP NO. B-4929	SHEET NO. PMP-6
APPROVED: <i>William J. Hamilton</i> 3/24/2016	
DATE: 3/24/2016	
SEAL 	
DOCUMENT NOT CONSIDERED FINAL UNLESS ALL SIGNATURES COMPLETED	

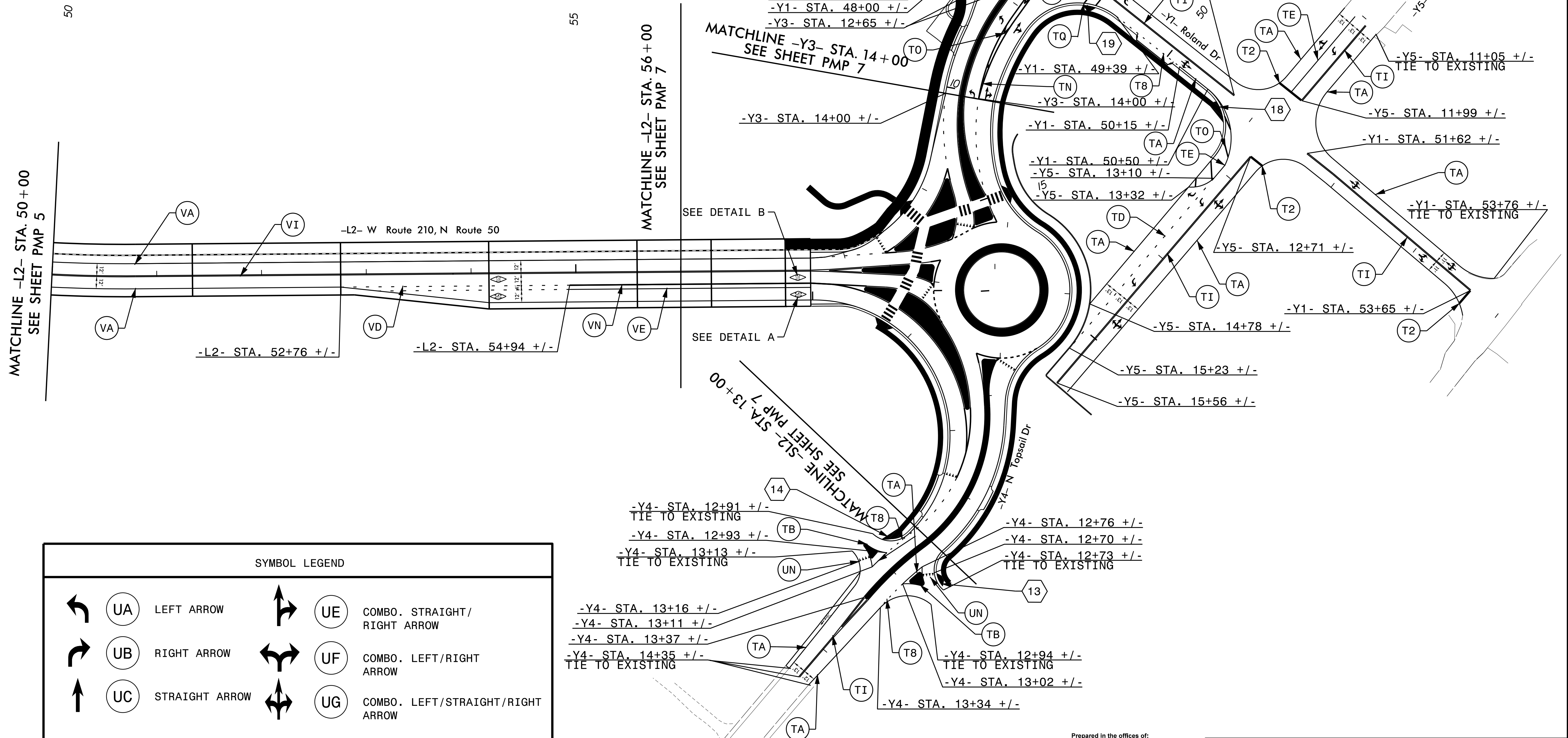

SYMBOL LEGEND					
	UA	LEFT ARROW		UE	COMBO. STRAIGHT/ RIGHT ARROW
	UB	RIGHT ARROW		UF	COMBO. LEFT/RIGHT ARROW
	UC	STRAIGHT ARROW		UG	COMBO. LEFT/STRAIGHT/RIGHT ARROW

Prepared in the offices of:

**RAMEY KEMP & ASSOCIATES, INC.**  
Transportation Engineers  
5808 Farrington Place, Suite 100  
Raleigh, North Carolina 27609  
919-872-5115 Tel. 919-878-5416 Fax.  
www.rameykemp.com

**PAVEMENT MARKING DETAIL**



8/17/99

3/24/2016 11:43:26 - pmp07.dgn  
User:tpope1.k

MAD 837NA 2011

TIP NO. <b>B-4929</b>	SHEET NO. <b>PMP-7</b>
APPROVED: <u>William J. Hamilton</u> 3/24/2016	
DATE: _____	
SEAL 	
<b>DOCUMENT NOT CONSIDERED FINAL UNLESS ALL SIGNATURES COMPLETED</b>	
SCALE 0 40 1" = 40'	

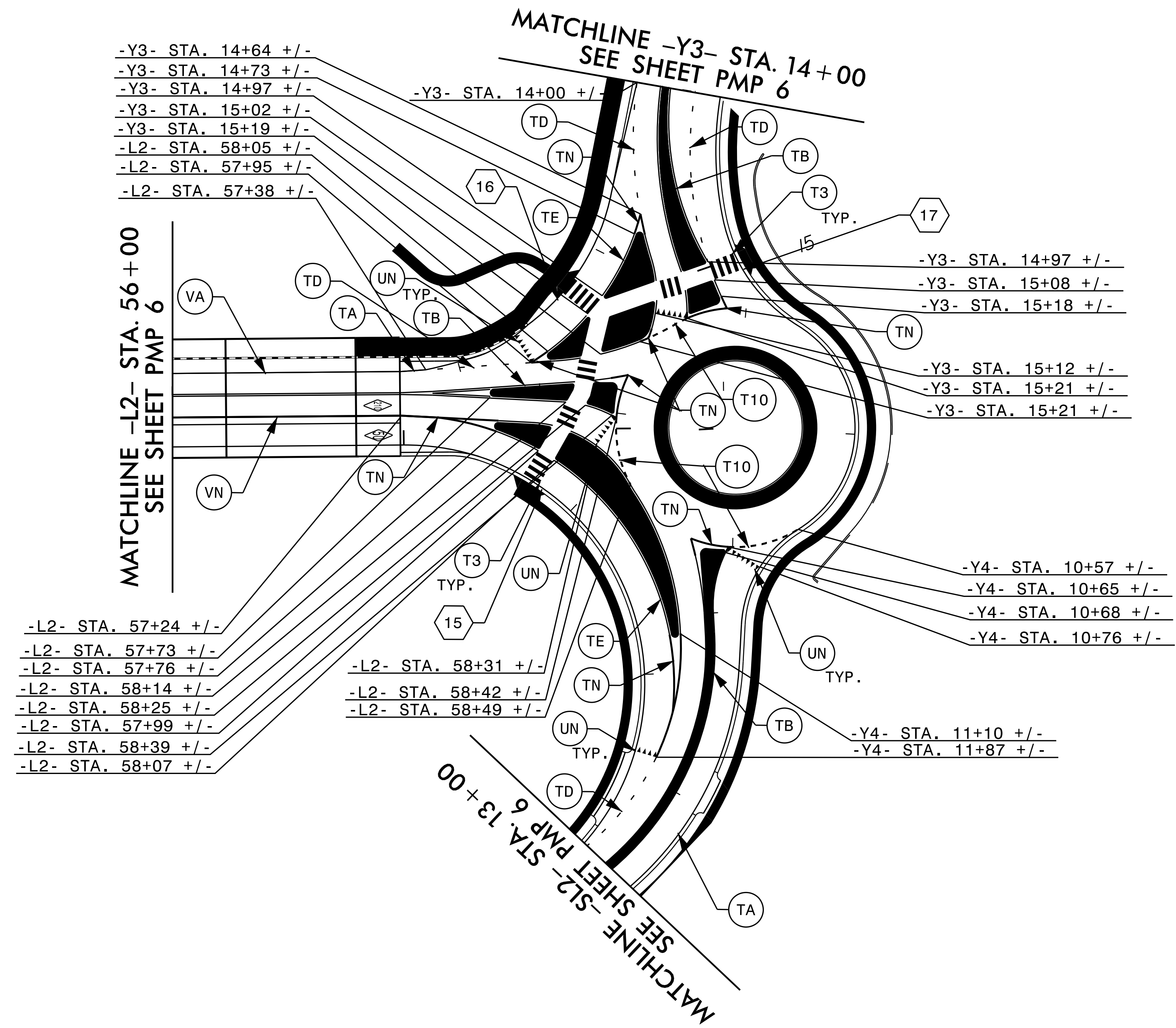

Prepared in the offices of:



**RAMEY KEMP & ASSOCIATES, INC.**  
Transportation Engineers  
8808 Farrington Place, Suite 100  
Raleigh, North Carolina 27609  
919-872-5115 Tel. 919-873-5416 Fax  
www.rameykemp.com

**PAVEMENT MARKING DETAIL**

8/17/99

TIP NO.	SHEET NO.
B-4929	PMP-8
APPROVED: <u>William J. Hamilton</u>	
DATE: 3/24/2016	
SEAL	
	
<b>DOCUMENT NOT CONSIDERED FINAL UNLESS ALL SIGNATURES COMPLETED</b>	

NAD 83/NA 2011

35

40

45

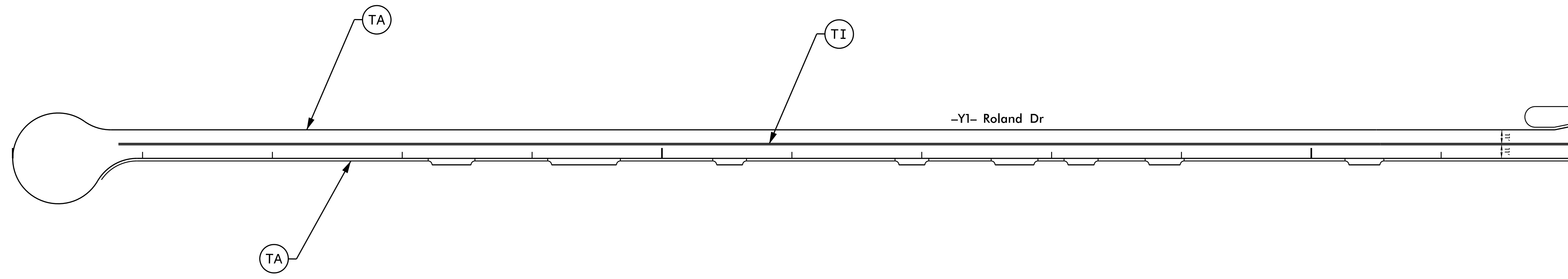

MATCHLINE -Y1- STA. 47 + 00  
SEE SHEET PMP 6

3/24/2016 11:48:42 AM  
T:\B-4929\_pmp08.dgn  
RAMEY KEMP, INC.

Prepared in the offices of:



**RAMEY KEMP  
ASSOCIATES, INC.**  
Transportation Engineers  
8808 Farrington Place, Suite 100  
Raleigh, North Carolina 27609  
919-872-5113 Tel. 919-872-5416 Fax  
www.rameykemp.com

# PAVEMENT MARKING DETAIL