

MAINLAND ROUNDABOUT DETAIL

PROJECT REFERENCE NO. B-4929	SHEET NO. 2B-1
---------------------------------	-------------------

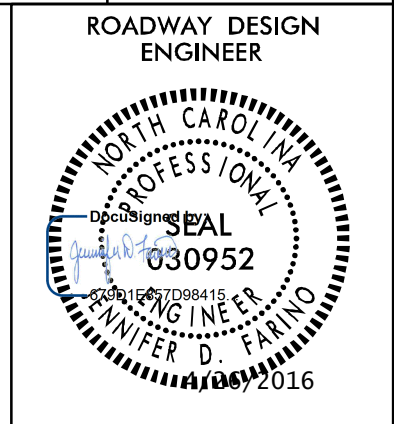

**DOCUMENT NOT CONSIDERED FINAL
UNLESS ALL SIGNATURES COMPLETED**

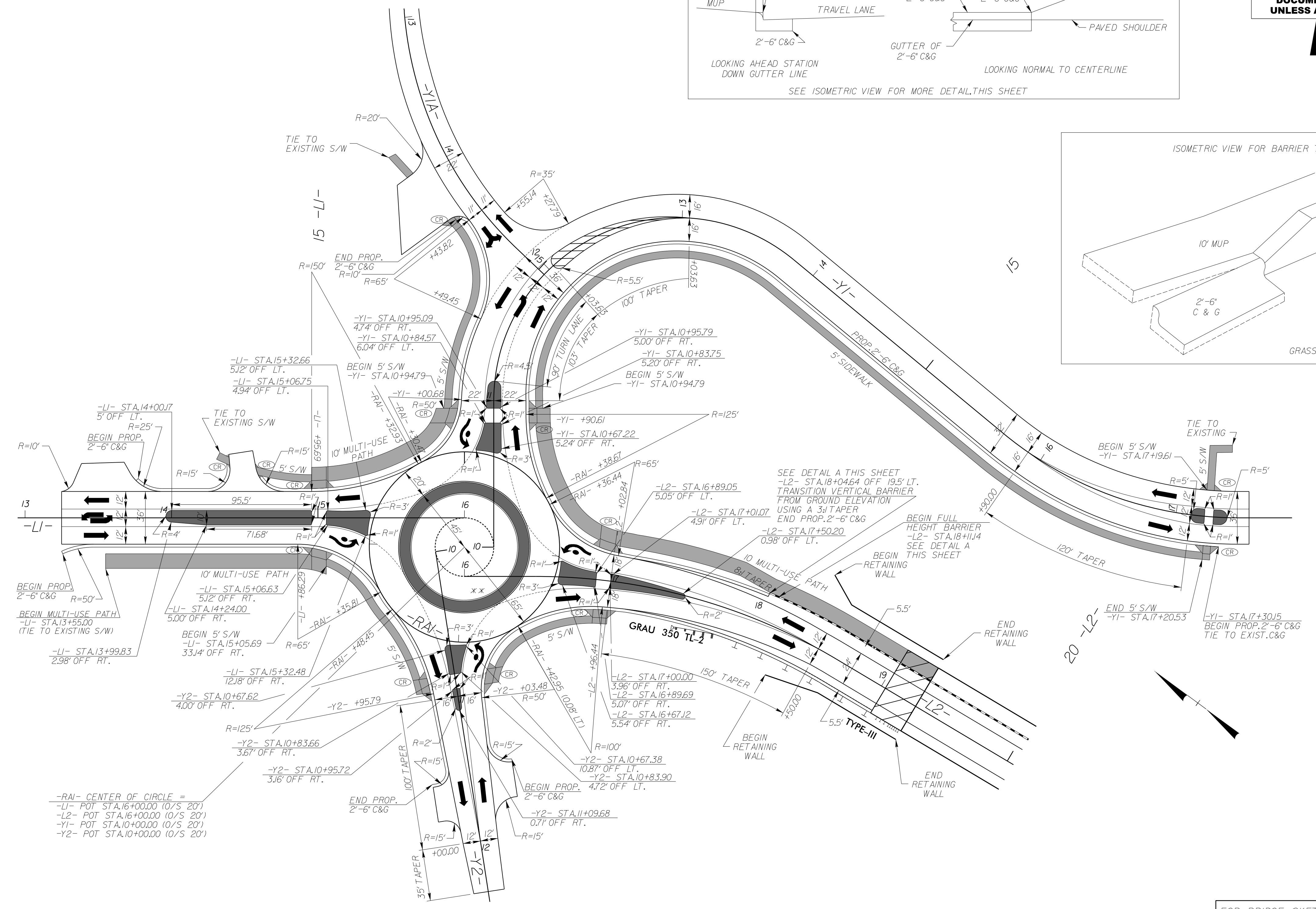
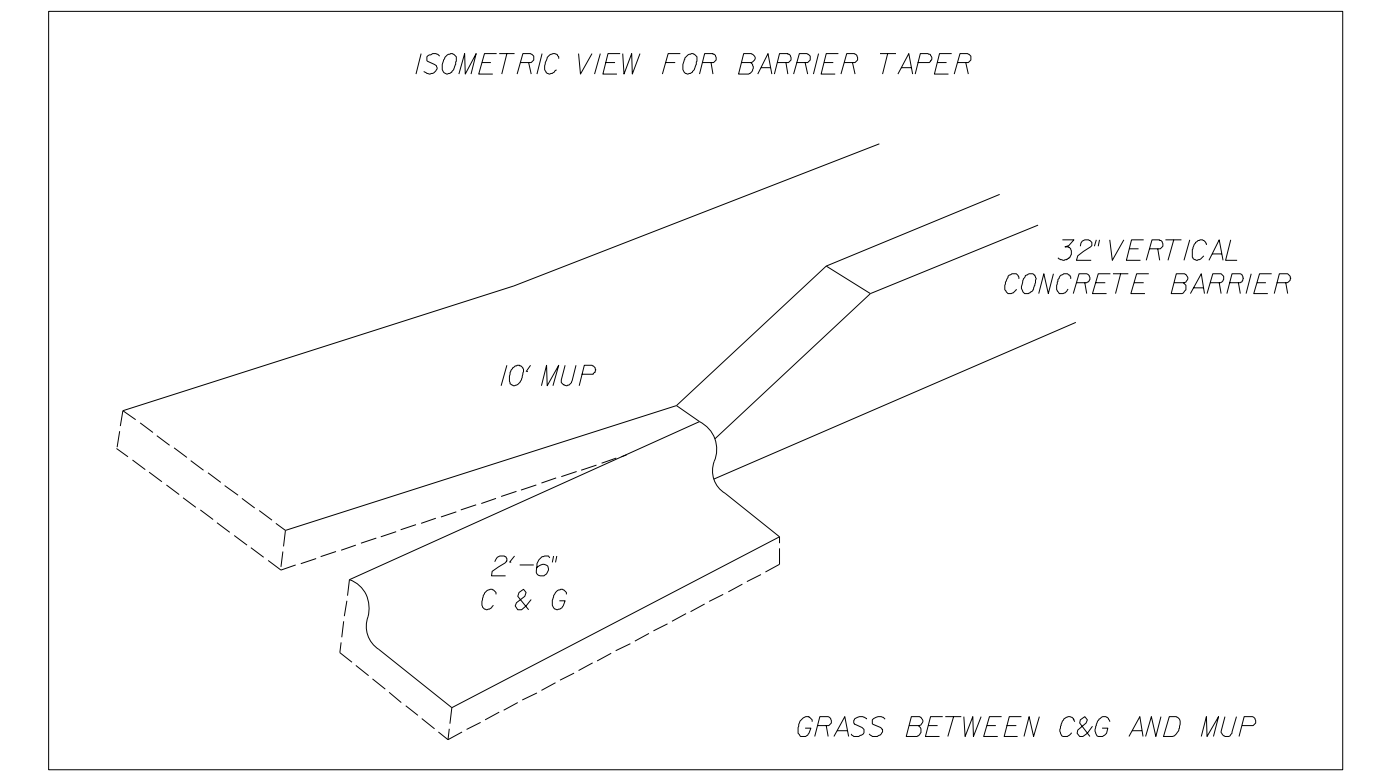
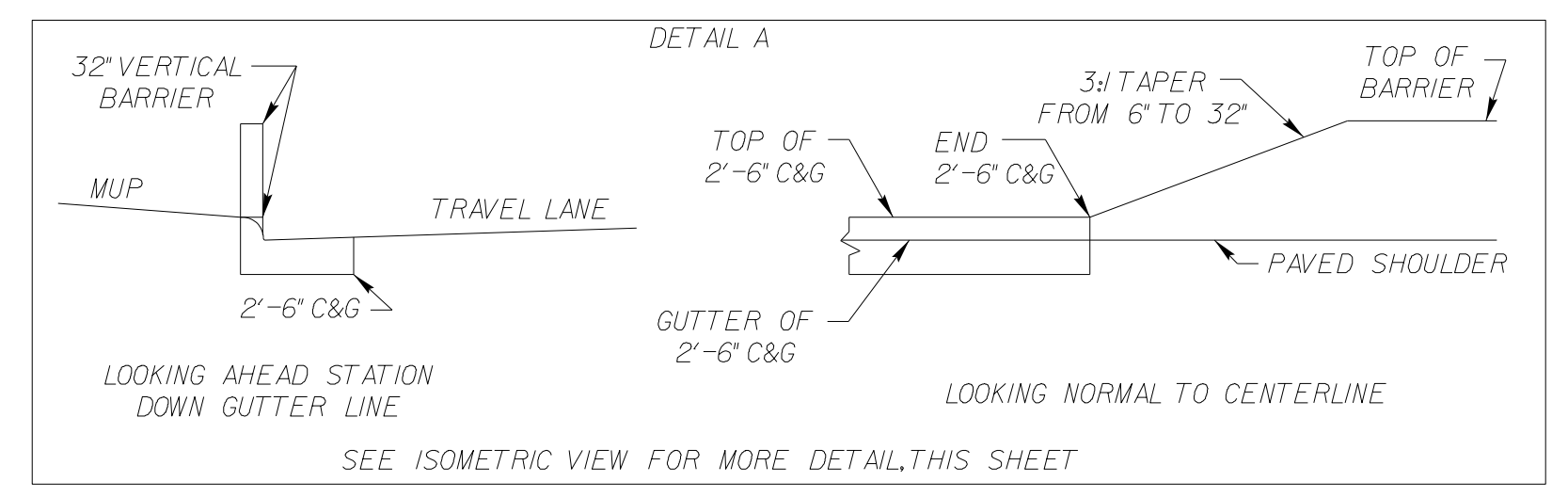

-RAI- CENTER OF CIRCLE =
 -LI- POT STA.16+00.00 (10/S 20')
 -L2- POT STA.16+00.00 (10/S 20')
 -Y1- POT STA.10+00.00 (10/S 20')
 -Y2- POT STA.10+00.00 (10/S 20')

NOTE: USE PEDESTRIAN HANDRAIL ALONG ENTIRE LENGTH OF -RW1- AND 48" CHAIN LINK FENCE ALONG ENTIRE LENGTH OF -RW2-.

** CONTRACTOR TO MATCH THE CURB AND GUTTER RADIAL EXPANSION/CONSTRUCTION JOINT TO THE CONCRETE APRON RADIAL EXPANSION CONSTRUCTION JOINT.

FOR BRIDGE SKETCH DETAIL, SEE SHEET 2B-3
FOR RETAINING WALL ENVELOPES, SEE SHEETS W-1 THRU W-4

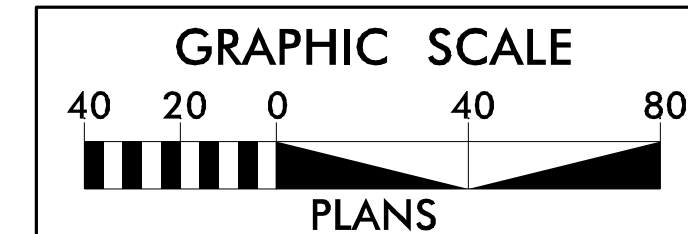

LOCATION: MAINLAND ROUNDABOUT DETAIL	
TIP NO.: B-4929	COUNTY: PENDER
DESIGNED BY: S. KORTOVICH, EI	
CHECKED BY: J. FARINO, PE	DATE: 4-17-15