

TYPICAL SECTION AT INTERMEDIATE DIAPHRAGM

* FOR INTERMEDIATE STEEL DIAPHRAGM DETAILS, SEE "INTERMEDIATE STEEL DIAPHRAGMS FOR TYPE III PRESTRESSED CONCRETE GIRDERS" SHEET.

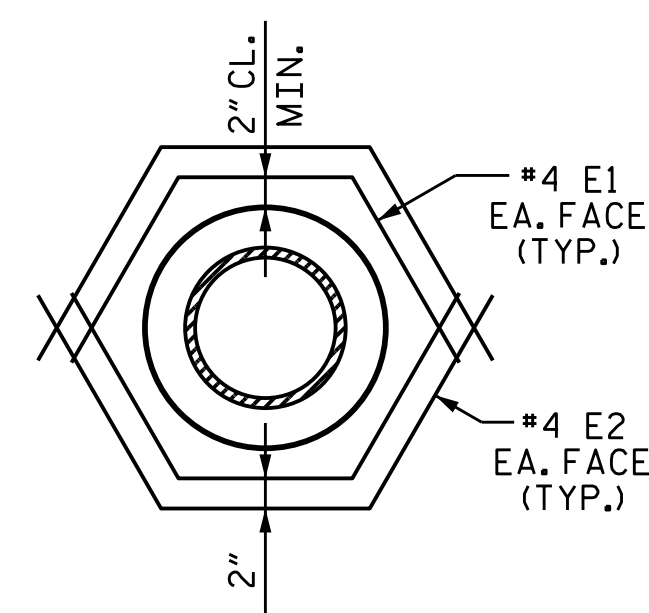

DETAIL "B"
8" Ø FORCE MAIN SEWER LINE IN 12" Ø BLOCKOUT

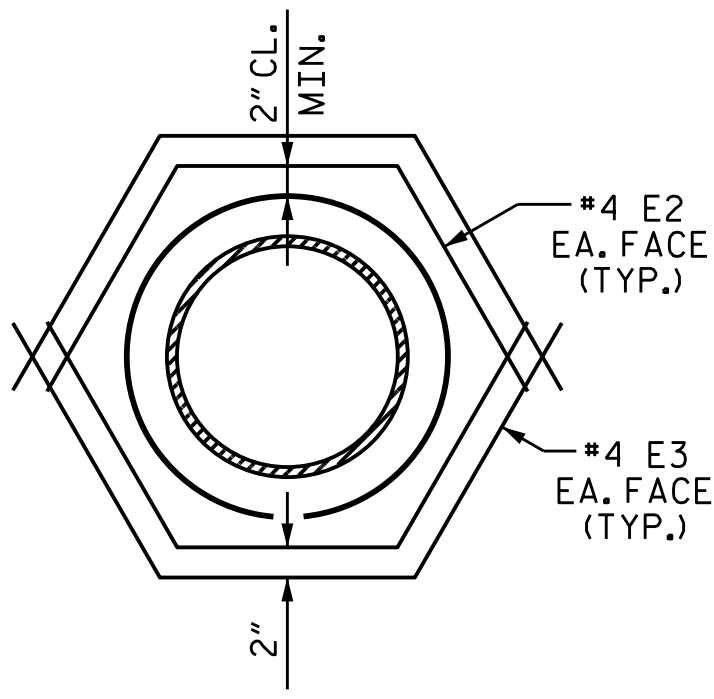

DETAIL "C"
12" Ø WATER LINE IN 16" Ø BLOCKOUT

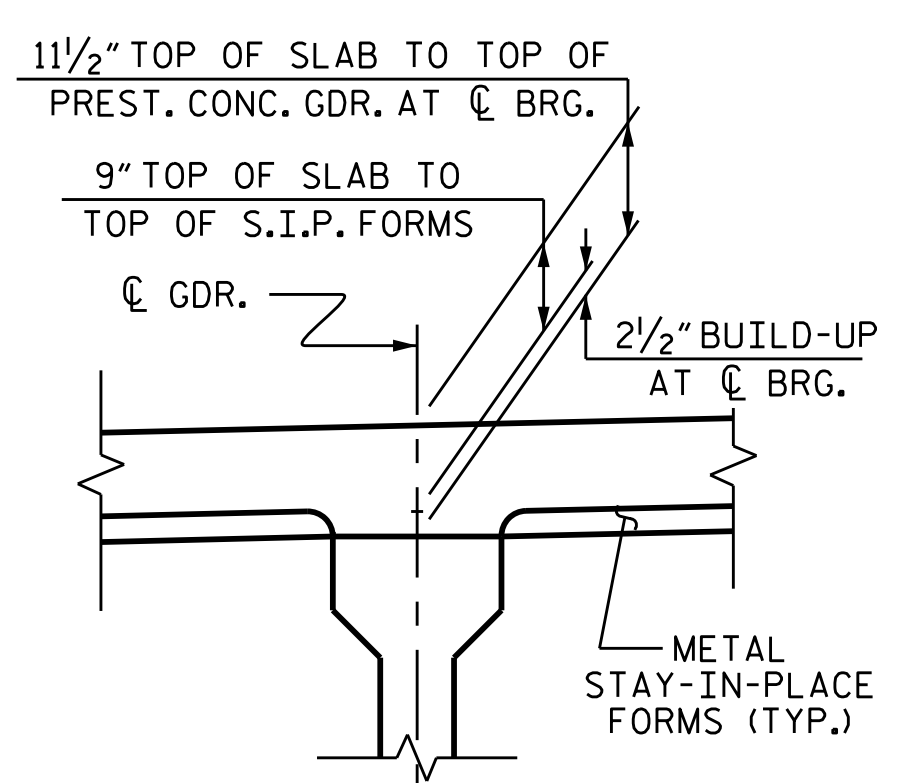

DETAIL "A"

PROJECT NO. B-5142
IREDELL COUNTY
STATION: 22+06.00 -L-

SHEET 3 OF 3

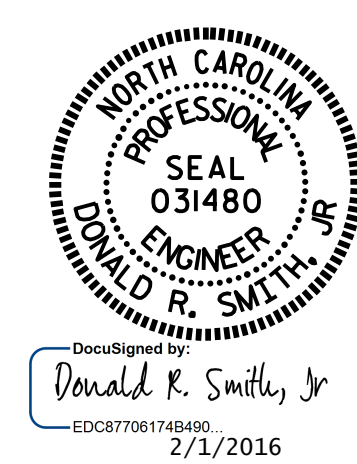

STATE OF NORTH CAROLINA
DEPARTMENT OF TRANSPORTATION
RALEIGH
SUPERSTRUCTURE
TYPICAL SECTION

DRAWN BY: K. D. LAYNE DATE: 4-27-15
CHECKED BY: J. D. HAWK DATE: 5-12-15
DESIGN ENGINEER OF RECORD: T. H. CARROLL DATE: 8-18-15

DOCUMENT NOT CONSIDERED
FINAL UNLESS ALL
SIGNATURES COMPLETED

REVISIONS						SHEET NO.
NO.	BY:	DATE:	NO.	BY:	DATE:	S-7
1			3			TOTAL SHEETS
2			4			38