

NOTES

STIRRUPS IN CAP MAY BE SHIFTED AS NECESSARY TO CLEAR DOWELS.

★ INVERT ALTERNATE STIRRUPS.

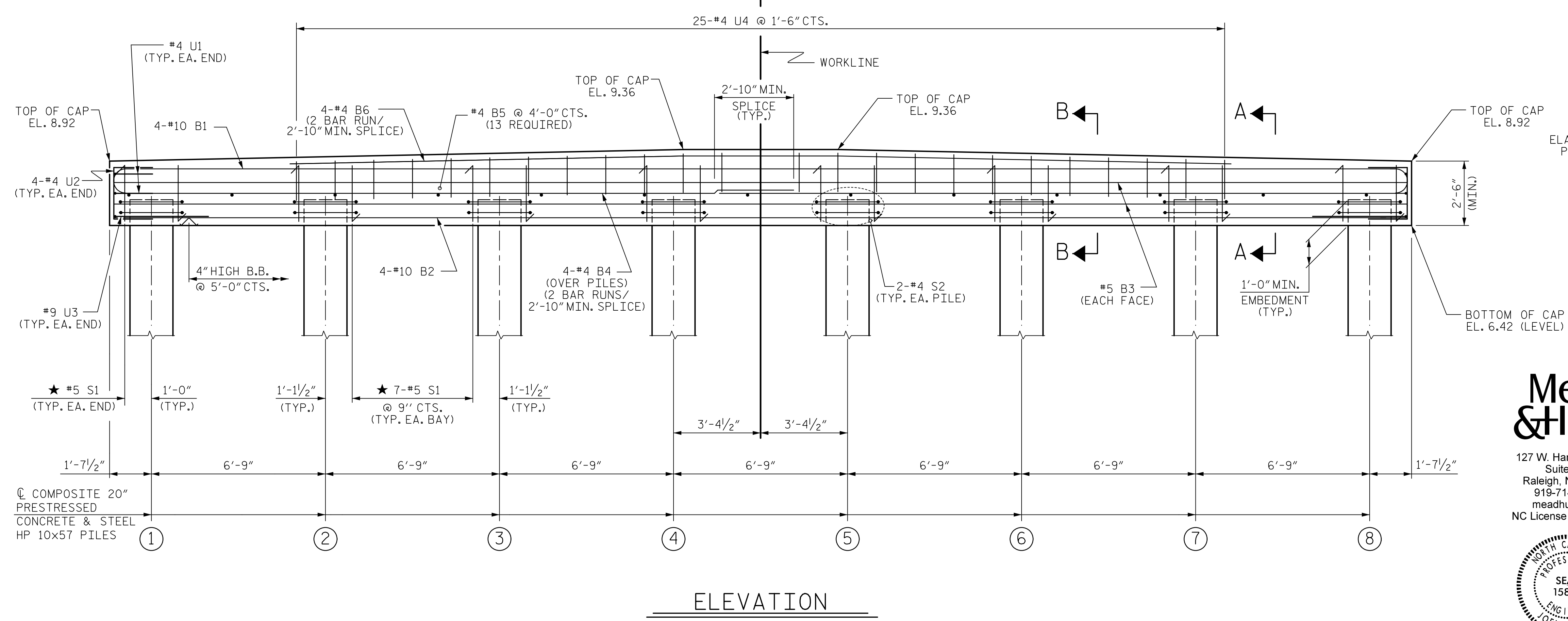
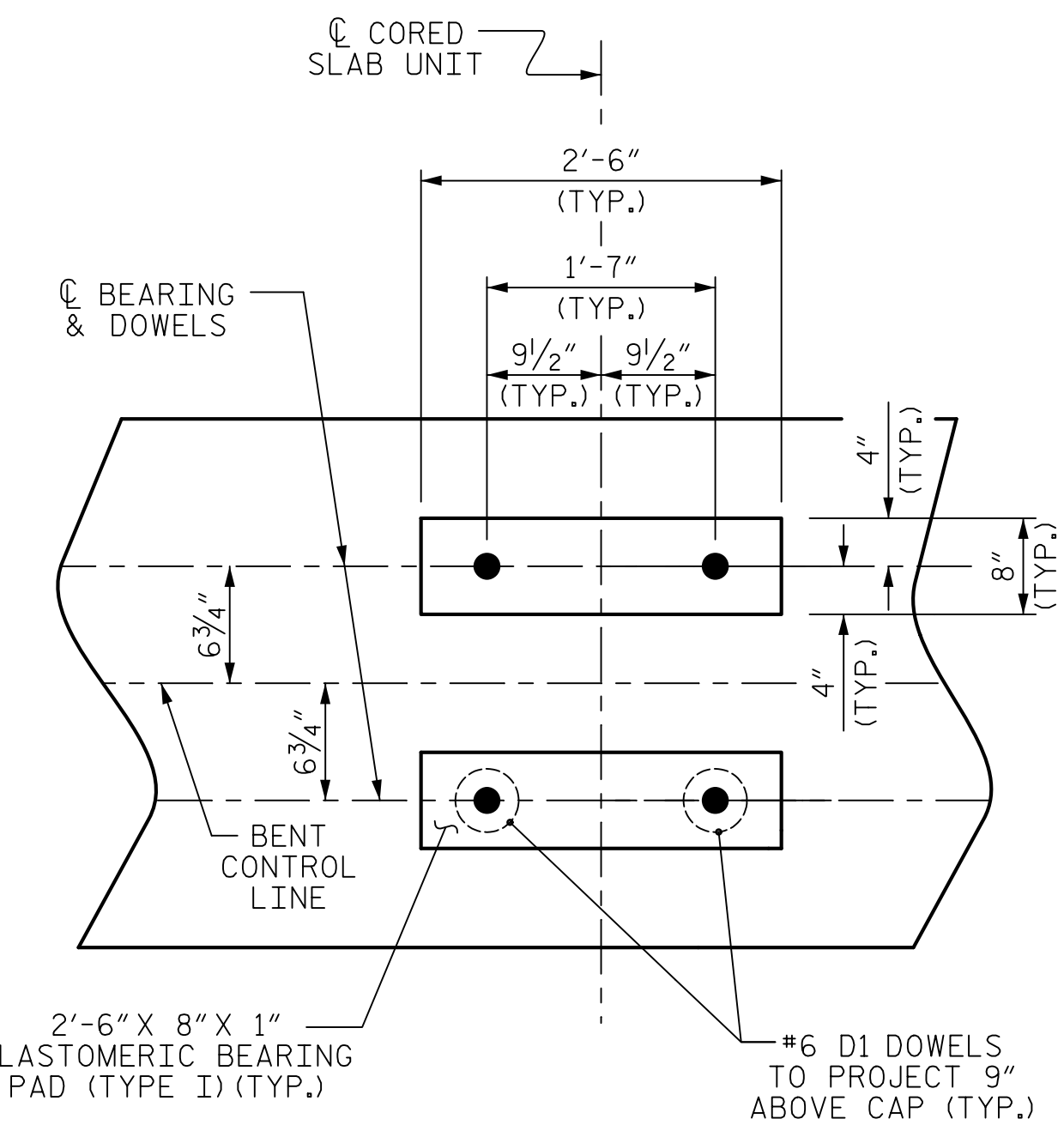
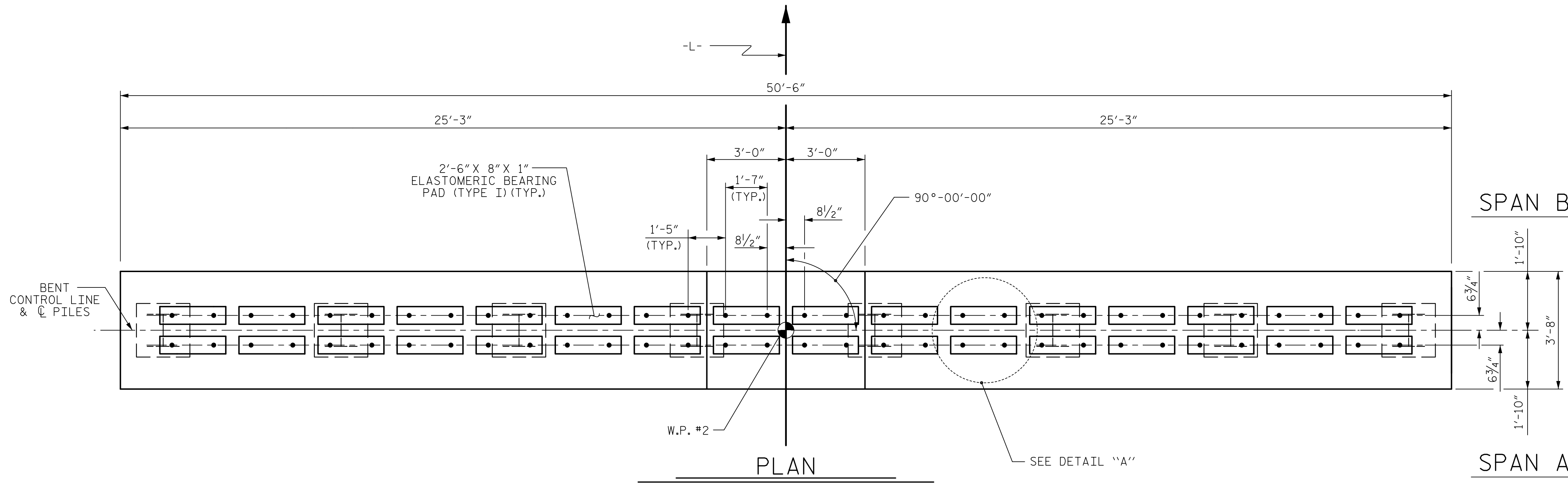

DETAIL "A"
(DIMENSIONS ARE TYPICAL EACH BEARING)

Mead & Hunt
127 W. Hargett Street
Suite 504
Raleigh, NC 27601
919-714-8670
meadhunt.com
NC License No. F-1235

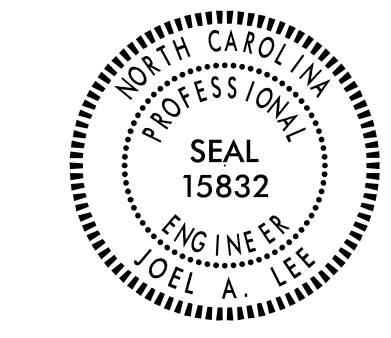

PROJECT NO. B-4440
BRUNSWICK COUNTY
STATION: 18+90.36 -L-

SHEET 1 OF 2

STATE OF NORTH CAROLINA
DEPARTMENT OF TRANSPORTATION
RALEIGH
SUBSTRUCTURE
BENT No. 1

DRAWN BY : J.S. HOBSON DATE : 2/16/15
CHECKED BY : J.A. LEE DATE : 2/19/15
DESIGN ENGINEER OF RECORD : J.A. LEE DATE : 2/19/15

DOCUMENT NOT CONSIDERED
FINAL UNLESS ALL
SIGNATURES COMPLETED

REVISIONS						SHEET NO.
NO.	BY:	DATE:	NO.	BY:	DATE:	5-18
1			3			TOTAL SHEETS
2			4			22