

NOTES

STIRRUPS IN CAP MAY BE SHIFTED AS NECESSARY TO CLEAR DOWELS.

THE CONCRETE IN THE SHADED AREA OF THE WING SHALL BE POURED AFTER THE CONCRETE PARAPET IS CAST IF SLIP FORMING IS USED.

FOR PILE SPLICE DETAILS, SEE SHEET 4 OF 4.

FOR WING DETAILS, SEE SHEET 3 OF 4.

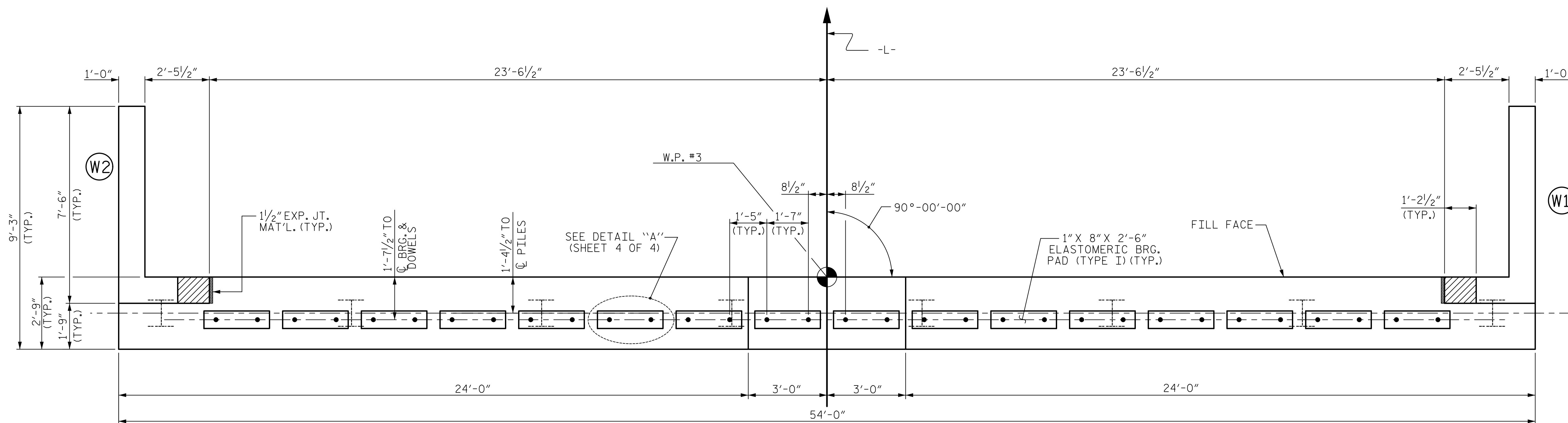

PLAN

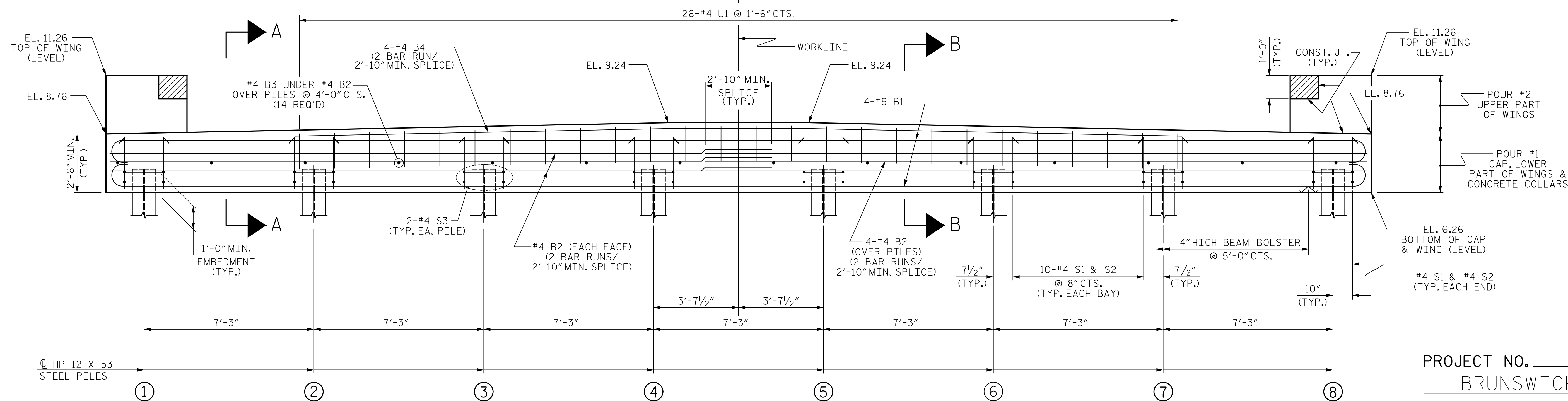

ELEVATION

WINGS NOT SHOWN FOR CLARITY.
 FOR SECTION A-A, SEE SHEET 4 OF 4.
 CONCRETE COLLARS FOR STEEL PILES NOT SHOWN IN PLAN AND ELEVATION VIEWS FOR CLARITY.
 SEE "CORROSION PROTECTION FOR STEEL PILES DETAIL", SHEET 4 OF 4.

PROJECT NO. B-4440
BRUNSWICK COUNTY
 STATION: 18+90.36 -L-

SHEET 2 OF 4

Mead & Hunt

127 W. Hargett Street
 Suite 504
 Raleigh, NC 27601
 919-714-8670
 meadhunt.com
 NC License No. F-1235

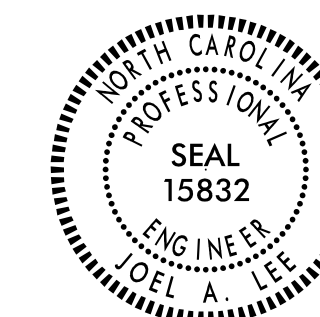

STATE OF NORTH CAROLINA
 DEPARTMENT OF TRANSPORTATION
 RALEIGH

SUBSTRUCTURE
 END BENT No. 2

DRAWN BY : J.S. HOBSON DATE : 2/13/15
 CHECKED BY : J.A. LEE DATE : 3/2/15
 DESIGN ENGINEER OF RECORD : J.A. LEE DATE : 3/2/15

DOCUMENT NOT CONSIDERED
 FINAL UNLESS ALL
 SIGNATURES COMPLETED

REVISIONS						SHEET NO.
NO.	BY:	DATE:	NO.	BY:	DATE:	S-15
1			3			TOTAL SHEETS
2			4			22