

ELEVATION VIEW

RIGHT SIDE OF STRUCTURE SHOWN.  
LEFT SIDE SIMILAR BY ROTATION.

NOTES

USE CLASS "A" CONCRETE WITH PEA GRAVEL AGGREGATE IN THE PRECAST CONCRETE PANELS. IN ADDITION TO THE #3 REINFORCING BARS, CONCRETE SHALL BE REINFORCED WITH POLYPROPYLENE FIBERS PER THE MANUFACTURERS' RECOMMENDATIONS.

PREFORMED BEARING PAD SHALL CONFORM TO SECTION 1079-1 OF THE STANDARD SPECIFICATIONS. AT THE CONTRACTOR'S OPTION, AN UNREINFORCED PLAIN ELASTOMERIC PAD MAY BE USED.

DECK EDGE BEAMS SHALL HAVE 5/8" Ø FORMED HOLES TO MATCH THE LOCATIONS OF THE REQUIRED ANCHORAGE OF THE MEDALLIONS AS SHOWN.

PRECAST PANELS SHALL BE CAST AFTER BRIDGE SUPERSTRUCTURE IS COMPLETED. FORMED HOLES IN PANELS SHALL BE CAST TO MATCH THE LOCATION OF THE FORMED HOLES IN THE DECK EDGE BEAMS. REINFORCING STEEL MAY BE SHIFTED SLIGHTLY DUE TO CHANGES IN THE FORMED HOLE LOCATIONS.

NO WORK MAY BE STARTED ON FABRICATION OF PRECAST PANELS UNTIL VECTOR DRAWINGS OF THE ARTWORK HAVE BEEN OBTAINED FROM THE DEPARTMENT. NO ADDITIONAL DESIGN SHALL BE REQUIRED.

MATERIAL FOR BOLTS AND THREADED RODS SHALL BE ASTM F593 ALLOY 304 STAINLESS STEEL WITH MINIMUM 75,000 PSI ULTIMATE STRENGTH. BOLTS TO BE EMBEDDED AS SHOWN. NUTS SHALL BE AMERICAN STANDARD FINISHED HEXAGON THICK, CLASS 2B THREAD, AND MEET THE REQUIREMENTS OF ASTM F594 ALLOY 304 STAINLESS STEEL. WASHERS SHALL MEET THE REQUIREMENTS OF ASTM F844 EXCEPT THEY SHALL BE MADE FROM ALLOY 304 STAINLESS STEEL.

FOR PRECAST PANELS, SEE SPECIAL PROVISIONS.

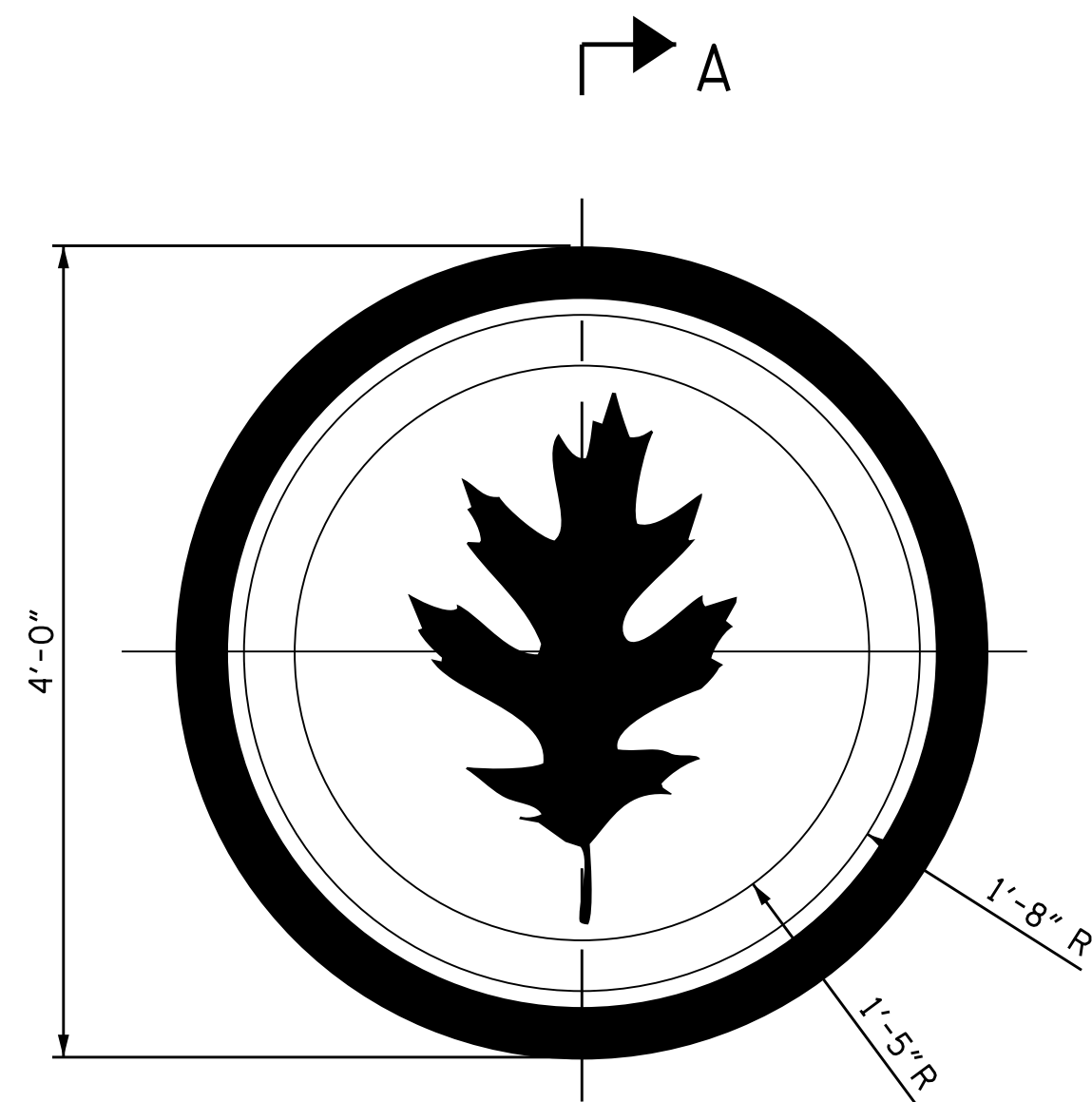

MEDALLION DETAIL

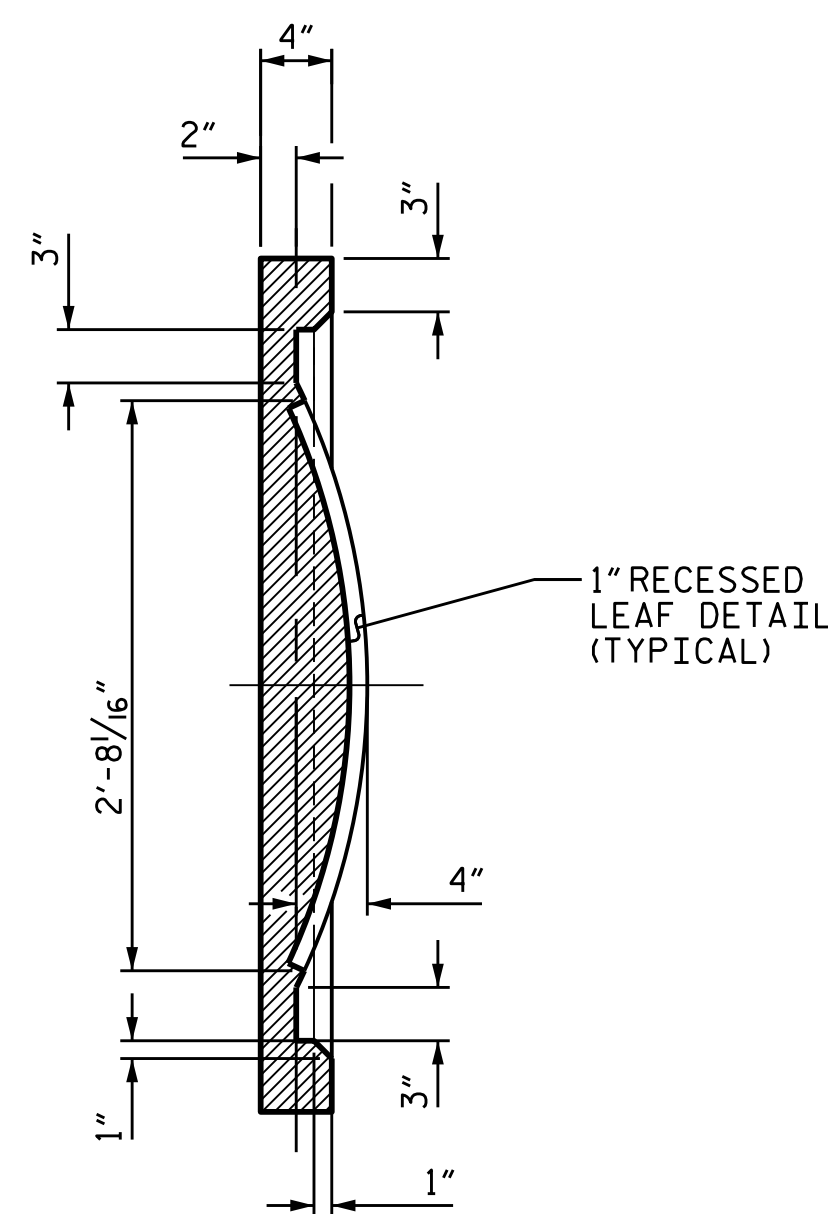

SECTION A-A

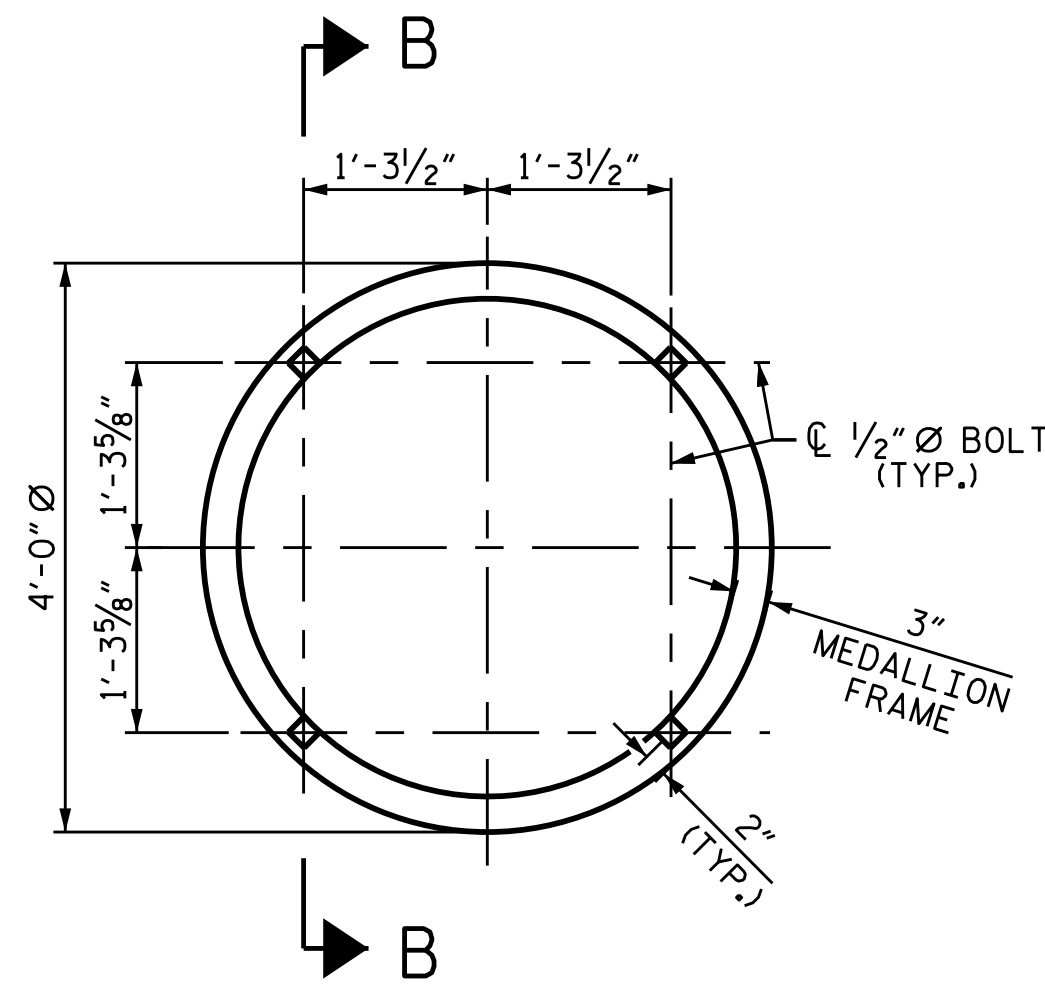

ANCHORAGE DIMENSIONS  
MEDALLION DETAILS NOT SHOWN FOR CLARITY

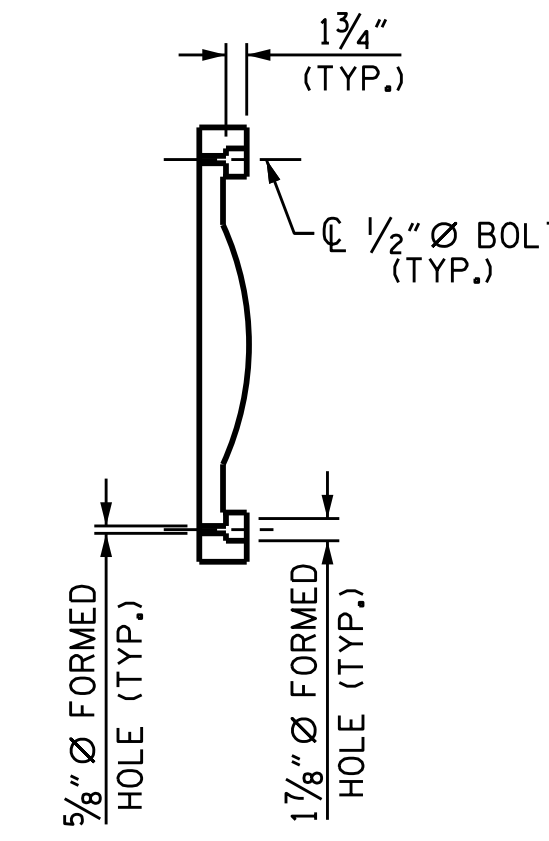

SECTION B-B

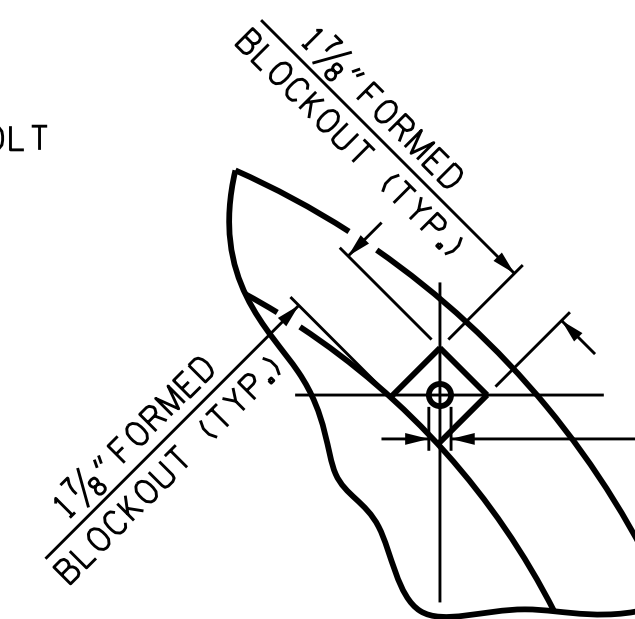

RECESS DETAILS

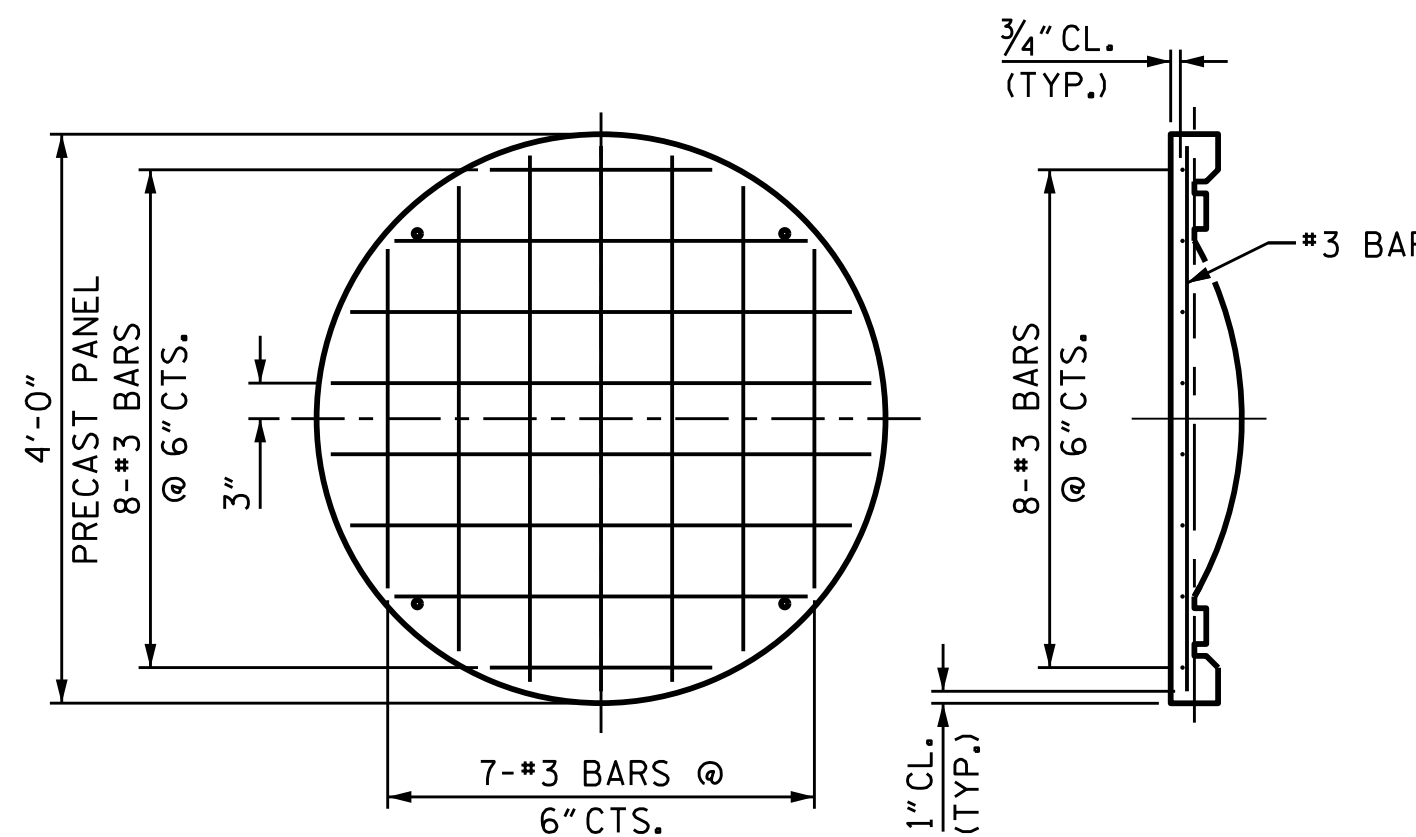
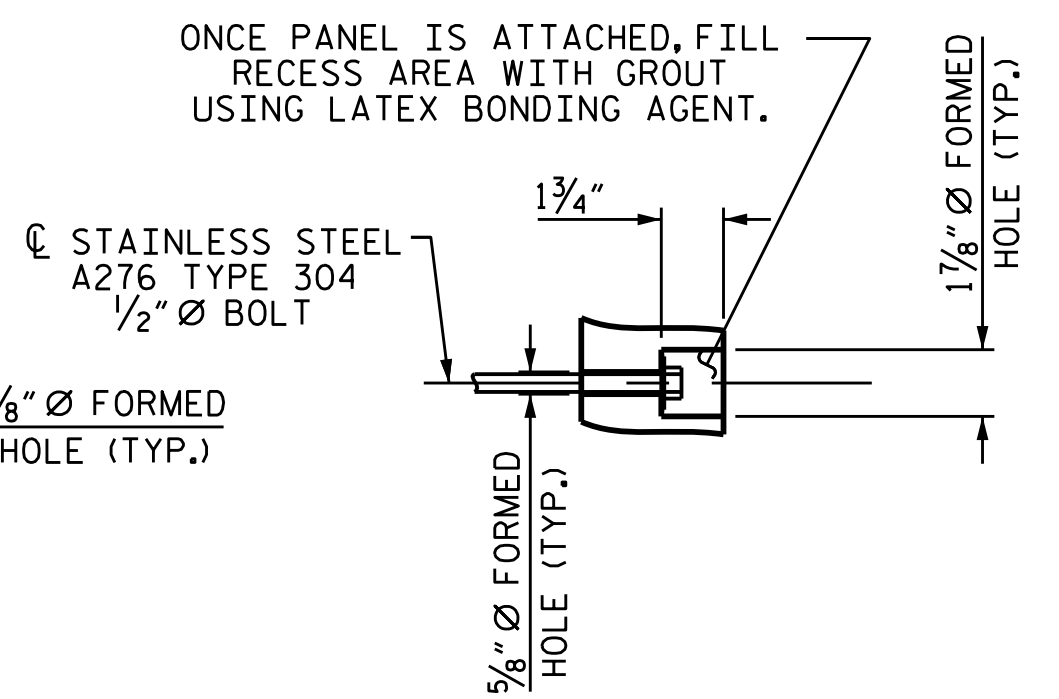

REINFORCING STEEL

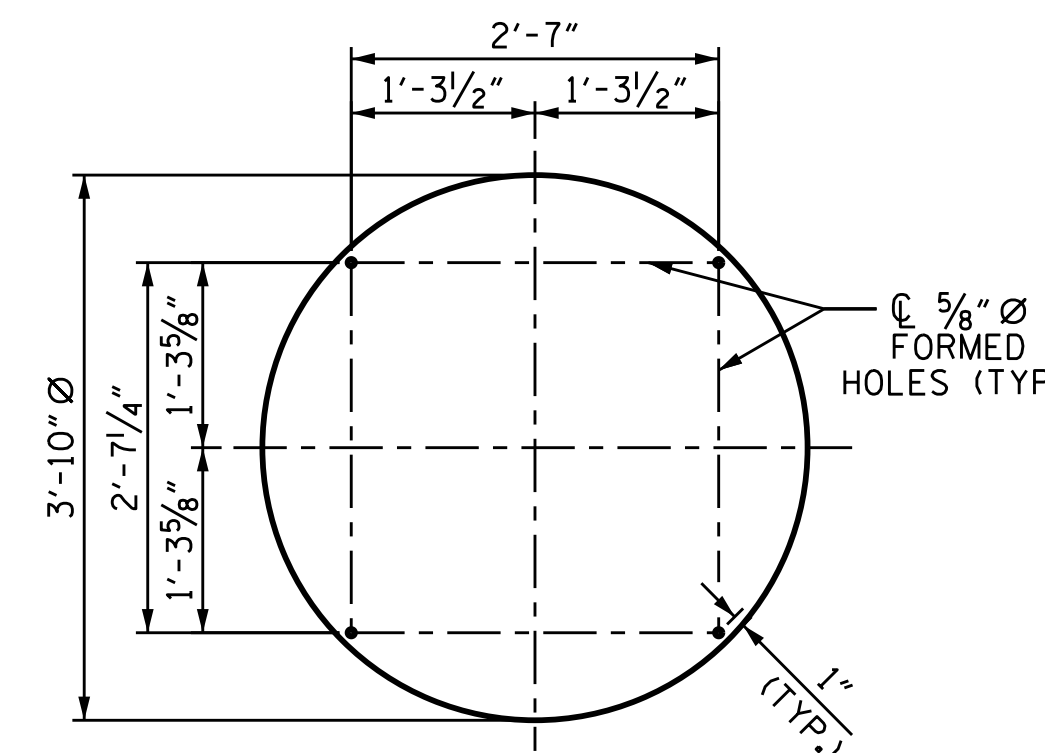

1/4" PREFORMED BEARING PAD

PRECAST MEDALLION

8 MEDALLIONS REQUIRED

PROJECT NO. B-5121/B-5317

WAKE COUNTY

STATION: 20+19.94 -FLYOVER-

SHEET 1 OF 2

STATE OF NORTH CAROLINA  
DEPARTMENT OF TRANSPORTATION  
RALEIGH

PRECAST PANELS

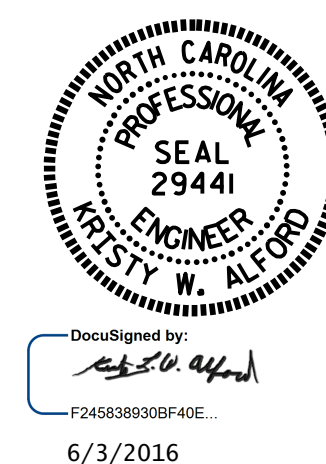

DocuSigned by:  
K.W. Alford  
F24583930BF40E  
6/3/2016

DRAWN BY: K.W. ALFORD DATE: 2/2016  
CHECKED BY: I.L. AVERETTE DATE: 2/2016  
DESIGN ENGINEER OF RECORD: K.W. ALFORD DATE: 2/2016

DOCUMENT NOT CONSIDERED  
FINAL UNLESS ALL  
SIGNATURES COMPLETED

| REVISIONS |     |       |     |     |       | SHEET NO.    |
|-----------|-----|-------|-----|-----|-------|--------------|
| NO.       | BY: | DATE: | NO. | BY: | DATE: | TOTAL SHEETS |
| 1         |     |       | 3   |     |       | S-107        |
| 2         |     |       | 4   |     |       | 110          |