

5/28/99

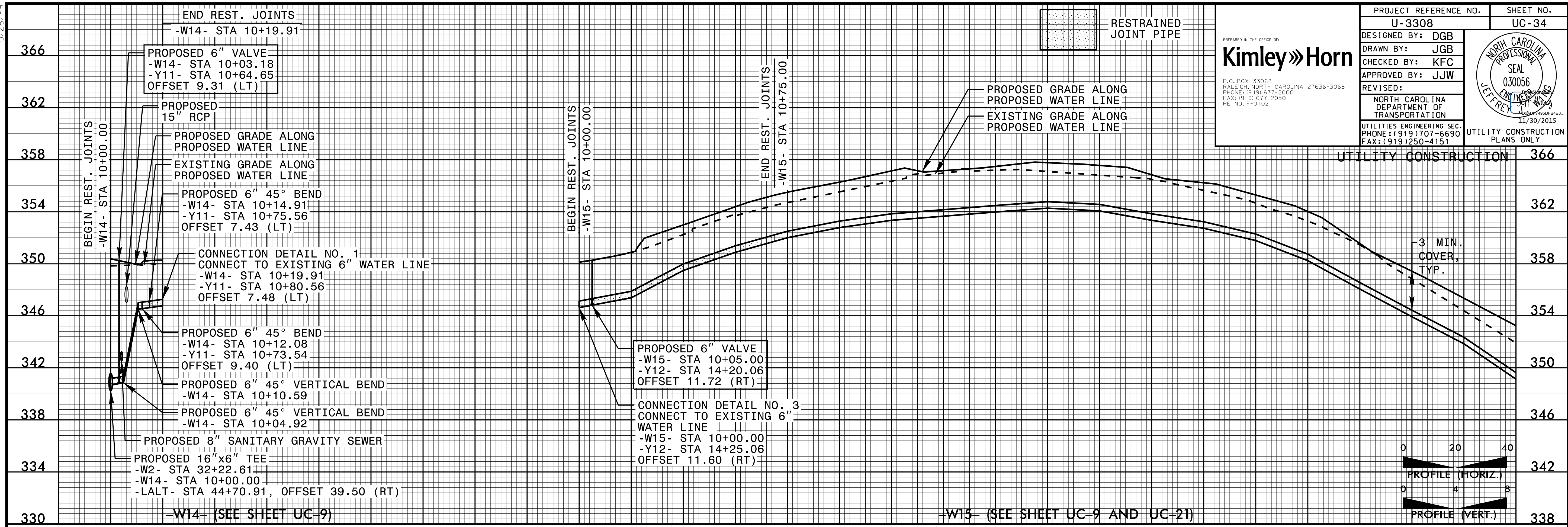

PROJECT REFERENCE NO. U-3308 SHEET NO. UC-34

DESIGNED BY: DGB
 DRAWN BY: JGB
 CHECKED BY: KFC
 APPROVED BY: JJW

REVISED:

NORTH CAROLINA DEPARTMENT OF TRANSPORTATION

UTILITIES ENGINEERING SEC. PHONE: (919) 707-6690 FAX: (919) 250-4151

UTILITY CONSTRUCTION PLANS ONLY

Kimley»Horn

P.O. BOX 33068 RALEIGH, NORTH CAROLINA 27636-3068
 PHONE: (919) 677-2000
 FAX: (919) 677-2050
 PE NO. P-0102

11/30/2015

030056

JEFFREY W. HORN, P.E.

5/28/99

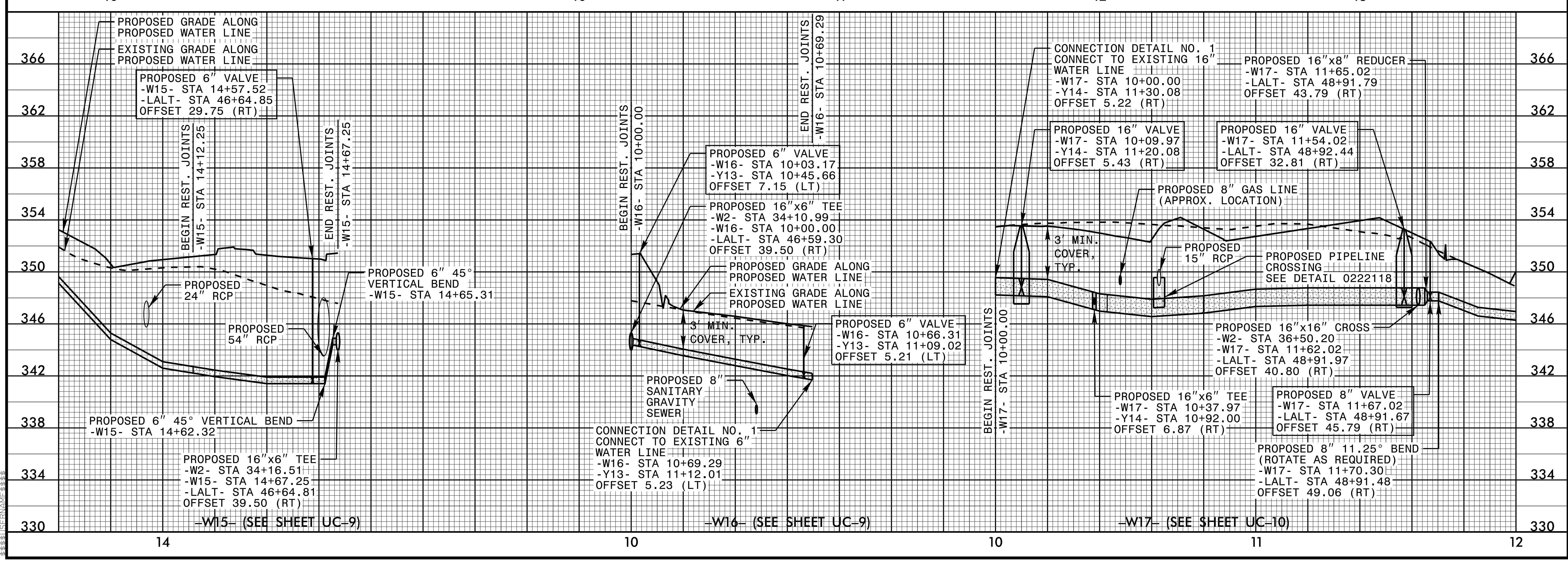

5/28/99

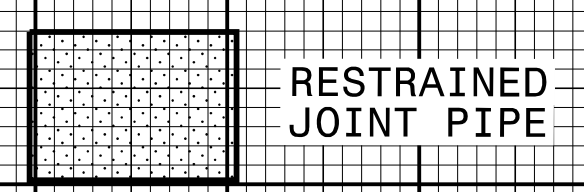
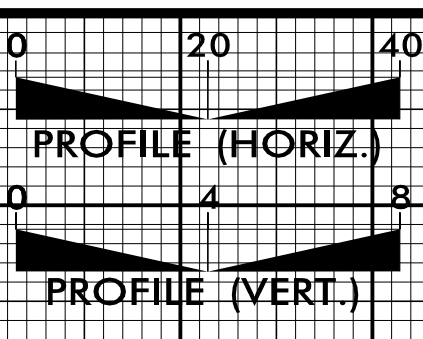

PROJECT REFERENCE NO. U-3308		SHEET NO. UC-32
DESIGNED BY: DGB		
DRAWN BY: JGB		
CHECKED BY: KFC		
APPROVED BY: JJW		
REVISIONS:	NORTH CAROLINA DEPARTMENT OF TRANSPORTATION UTILITIES ENGINEERING SEC. PHONE: (919) 707-6690 FAX: (919) 250-4151 UTILITY CONSTRUCTION PLANS ONLY	

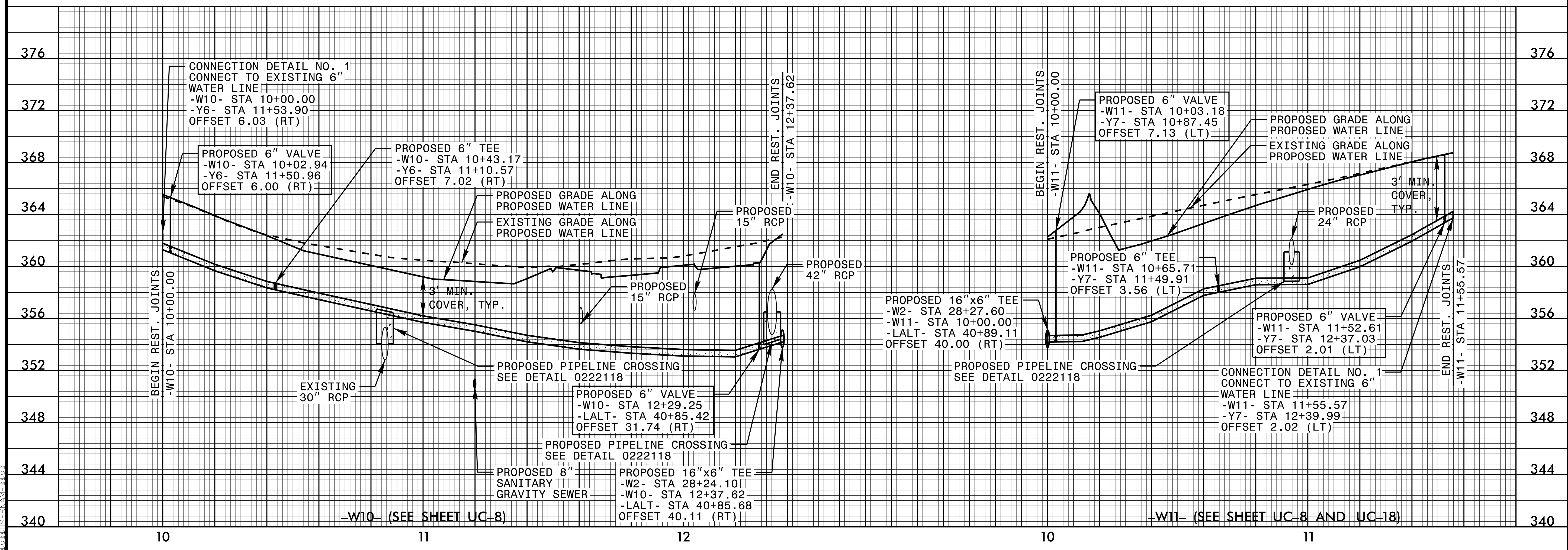
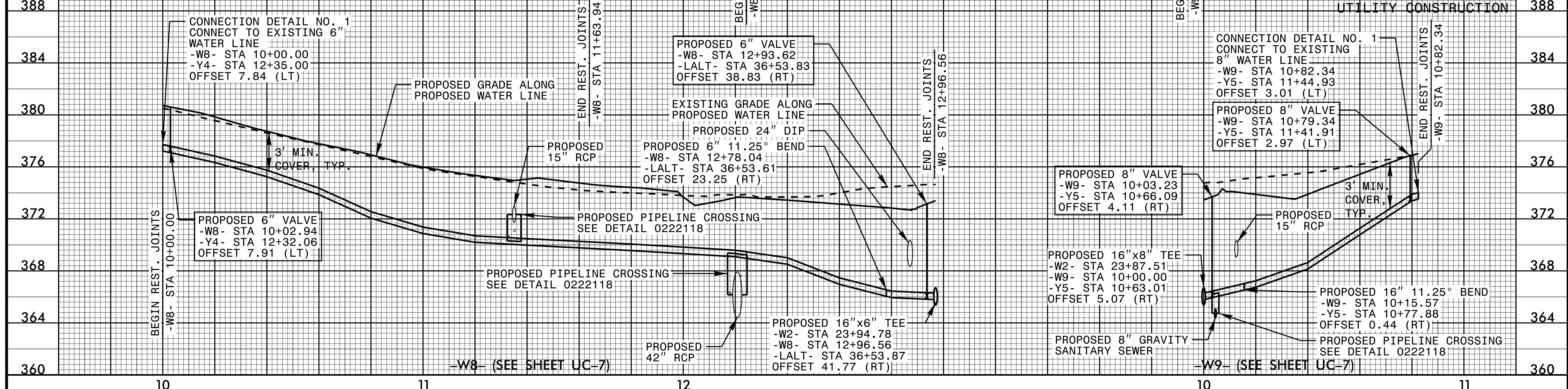

5/28/99

5/28/99

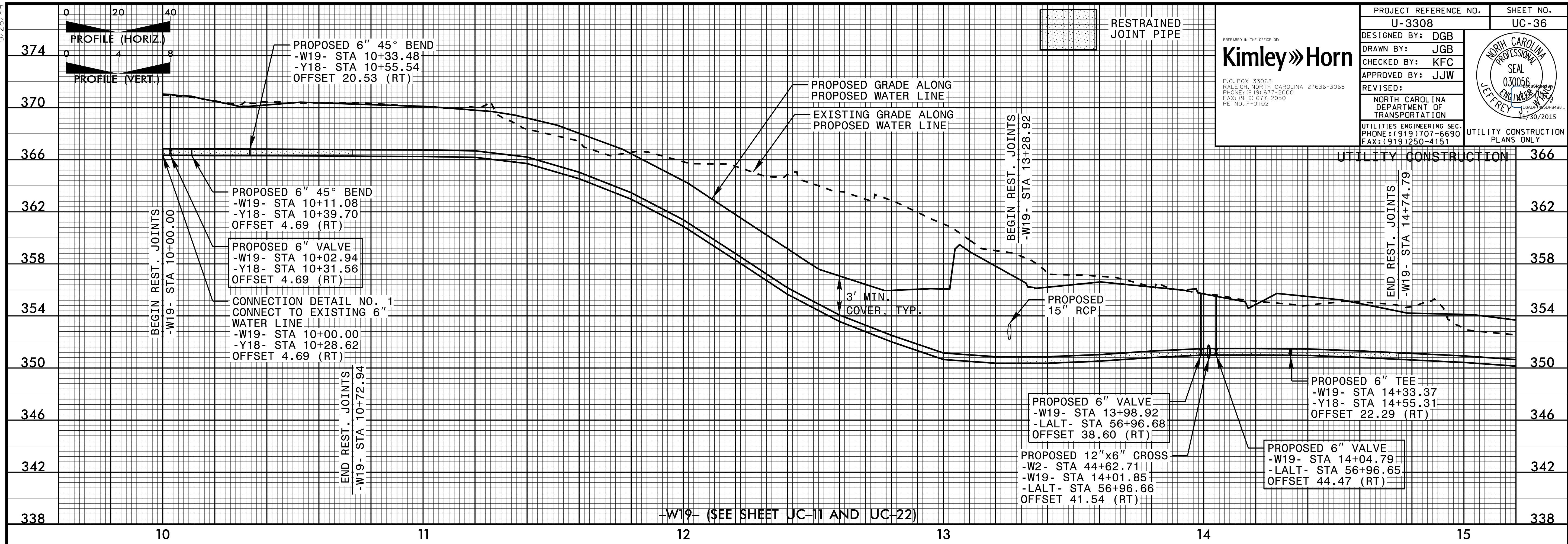

PROJECT REFERENCE NO. U-3308 SHEET NO. UC-36

DESIGNED BY: DGB
DRAWN BY: JGB
CHECKED BY: KFC
APPROVED BY: JJW

REVISIONS:

Kimley»Horn

P.O. BOX 33068
RALEIGH, NORTH CAROLINA 27636-3068
PHONE: (919) 677-2000
FAX: (919) 677-2050
PE NO. P-0102

NORTH CAROLINA PROFESSIONAL SEAL
030056
JEFFREY J. HORN
11/30/2015

UTILITIES ENGINEERING SEC.
PHONE: (919) 707-6690
FAX: (919) 250-4151

UTILITY CONSTRUCTION PLANS ONLY

5/28/99

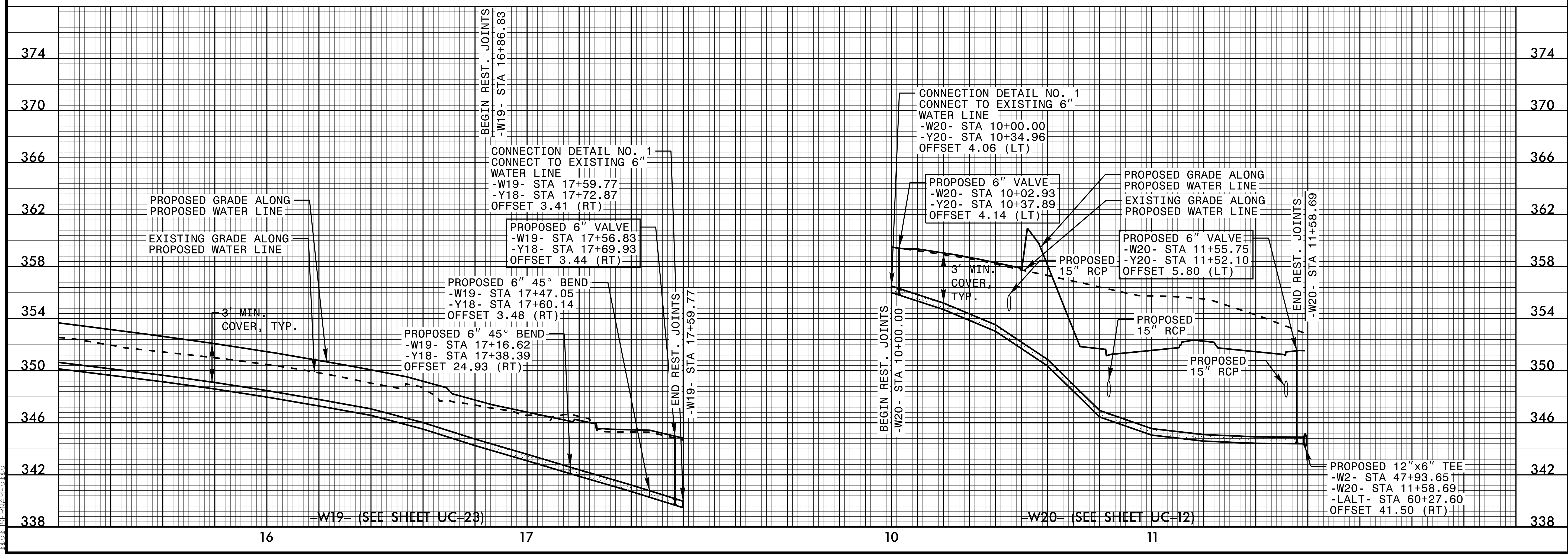

5/28/99

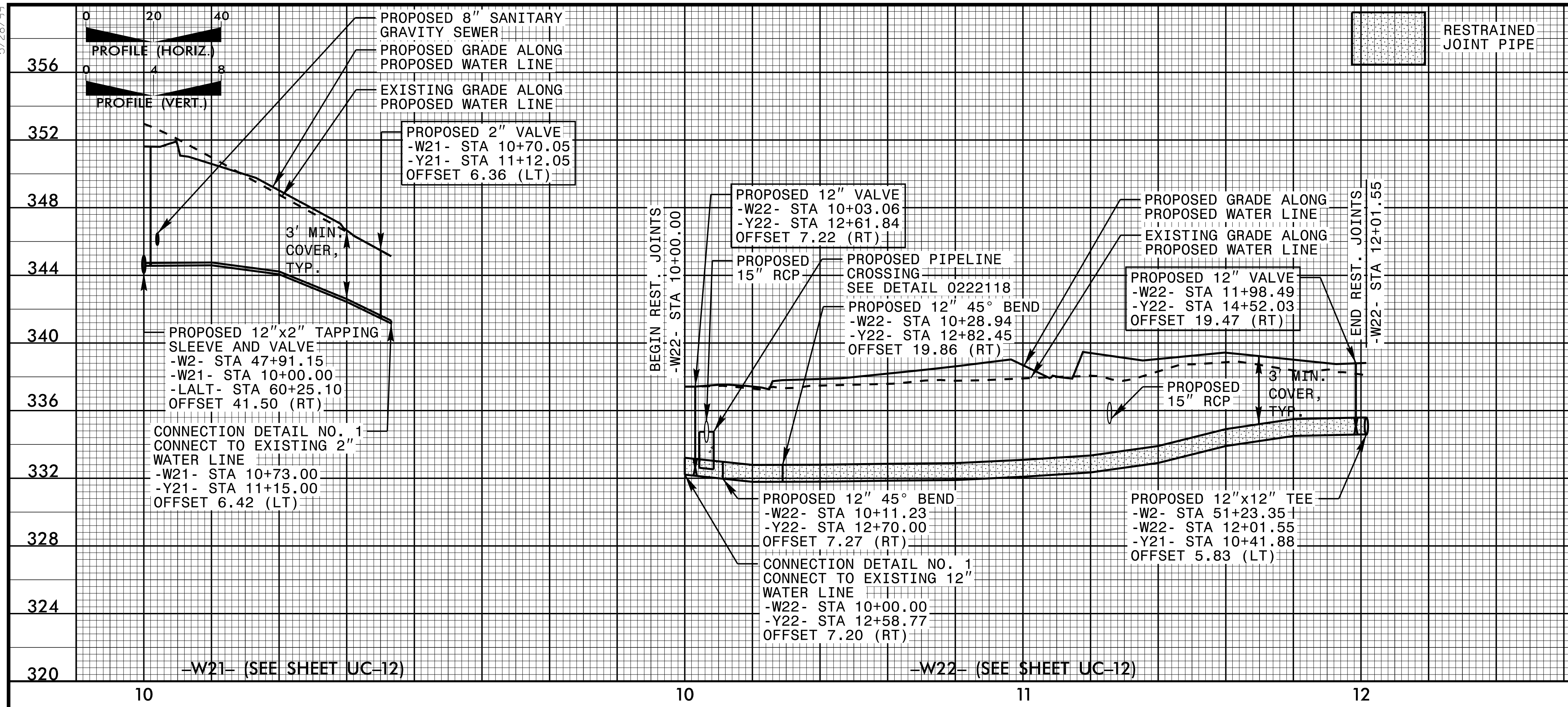

PROJECT REFERENCE NO. U-3308	SHEET NO. UC-37
DESIGNED BY: DGB	
DRAWN BY: JGB	
CHECKED BY: KFC	
APPROVED BY: JJW	NORTH CAROLINA DEPARTMENT OF TRANSPORTATION UTILITIES ENGINEERING SEC. PHONE: (919) 707-6690 FAX: (919) 250-4151
PREPARED IN THE OFFICE OF: Kimley»Horn <small>P.O. BOX 33068 RALEIGH, NORTH CAROLINA 27636-3068 PHONE: (919) 677-2000 FAX: (919) 677-2050 PE NO. P-0102</small>	

UTILITY CONSTRUCTION 348

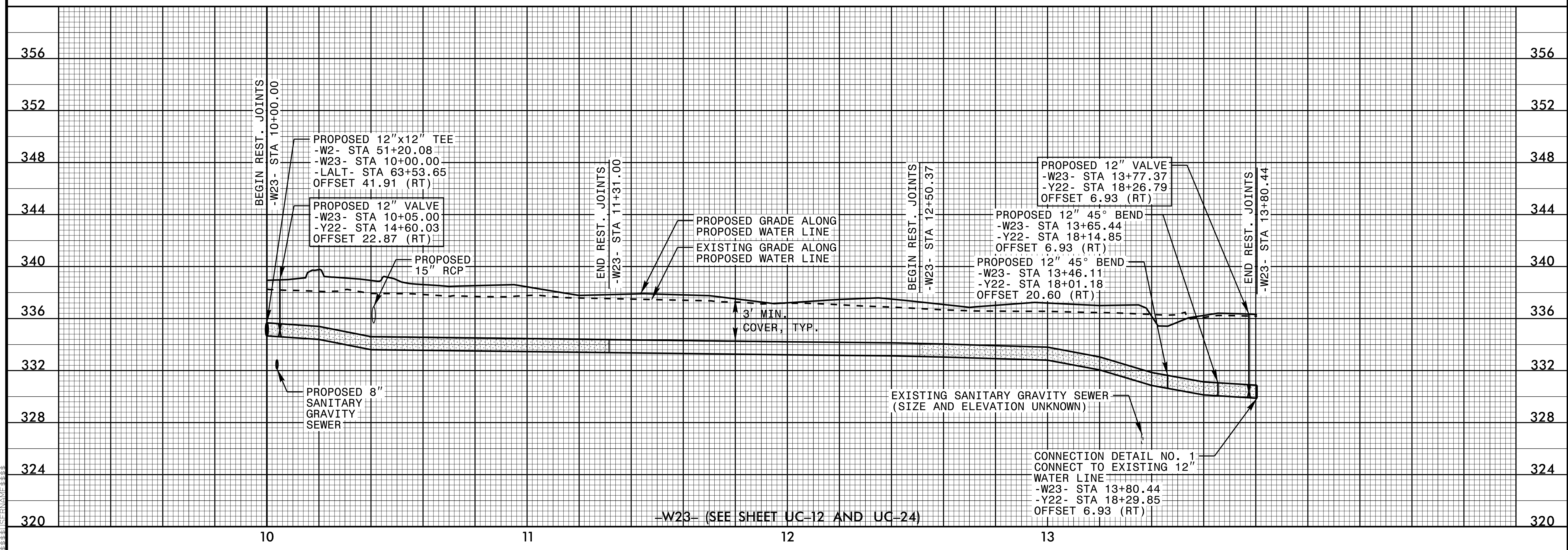

5/28/99

UTILITY CONSTRUCTION 348

UTILITY CONSTRUCTION 344

UTILITY CONSTRUCTION 340

UTILITY CONSTRUCTION 336

UTILITY CONSTRUCTION 332

UTILITY CONSTRUCTION 328

UTILITY CONSTRUCTION 324

UTILITY CONSTRUCTION 320

UTILITY CONSTRUCTION 356

UTILITY CONSTRUCTION 352

UTILITY CONSTRUCTION 348

UTILITY CONSTRUCTION 344

UTILITY CONSTRUCTION 340

UTILITY CONSTRUCTION 336

UTILITY CONSTRUCTION 332

UTILITY CONSTRUCTION 328

UTILITY CONSTRUCTION 324

UTILITY CONSTRUCTION 320

-W23- (SEE SHEET UC-12 AND UC-24)

5/28/99

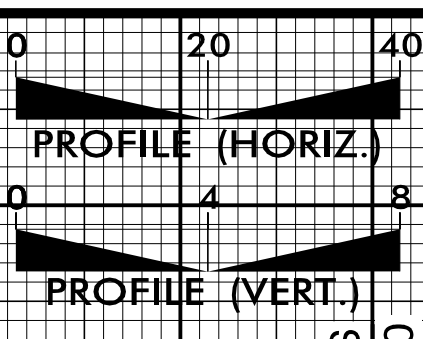

RESTRAINED JOINT PIPE

PROJECT REFERENCE NO. U-3308 SHEET NO. UC-38

DESIGNED BY: DGB
DRAWN BY: JGB
CHECKED BY: KFC
APPROVED BY: JJW

REVIS: NORTH CAROLINA DEPARTMENT OF TRANSPORTATION

UTILITIES ENGINEERING SEC. PHONE: (919) 707-6690 FAX: (919) 250-4151

UTILITY CONSTRUCTION PLANS ONLY

Kimley»Horn
P.O. BOX 33068 RALEIGH, NORTH CAROLINA 27636-3068
PHONE: (919) 677-2000 FAX: (919) 677-2050
PE NO. P-0102

NORTH CAROLINA PROFESSIONAL SEAL
030056
JEFFREY L. JEFFREY
12/30/2015

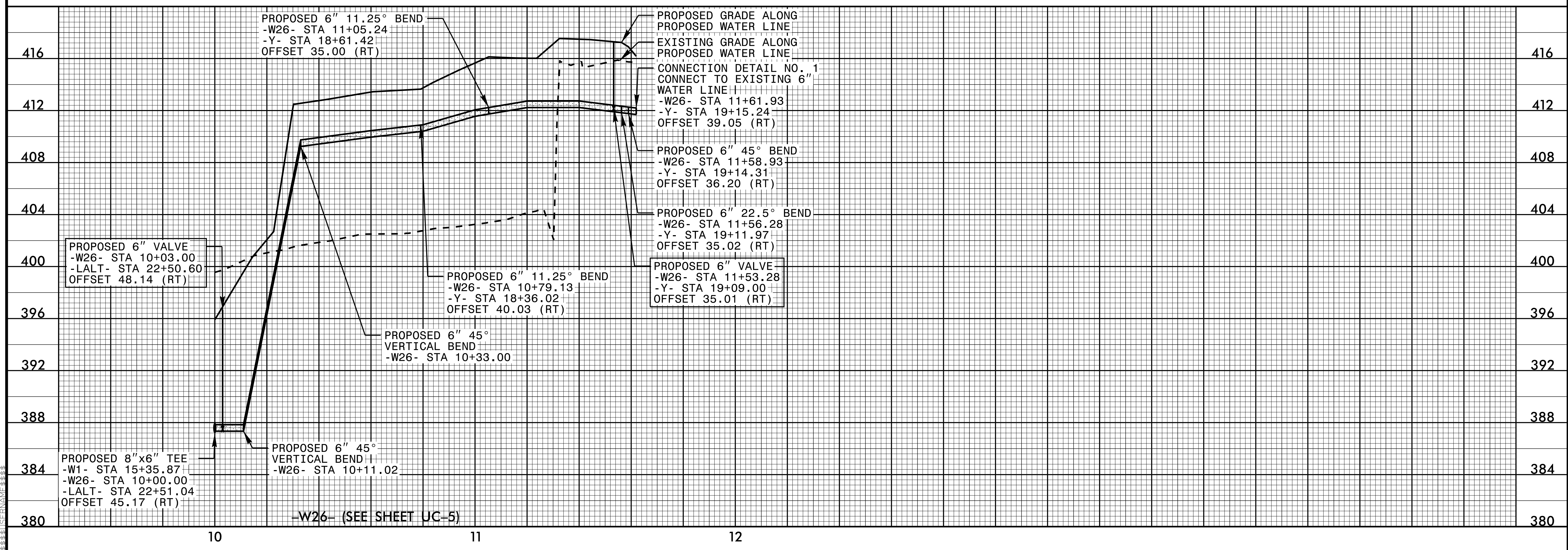
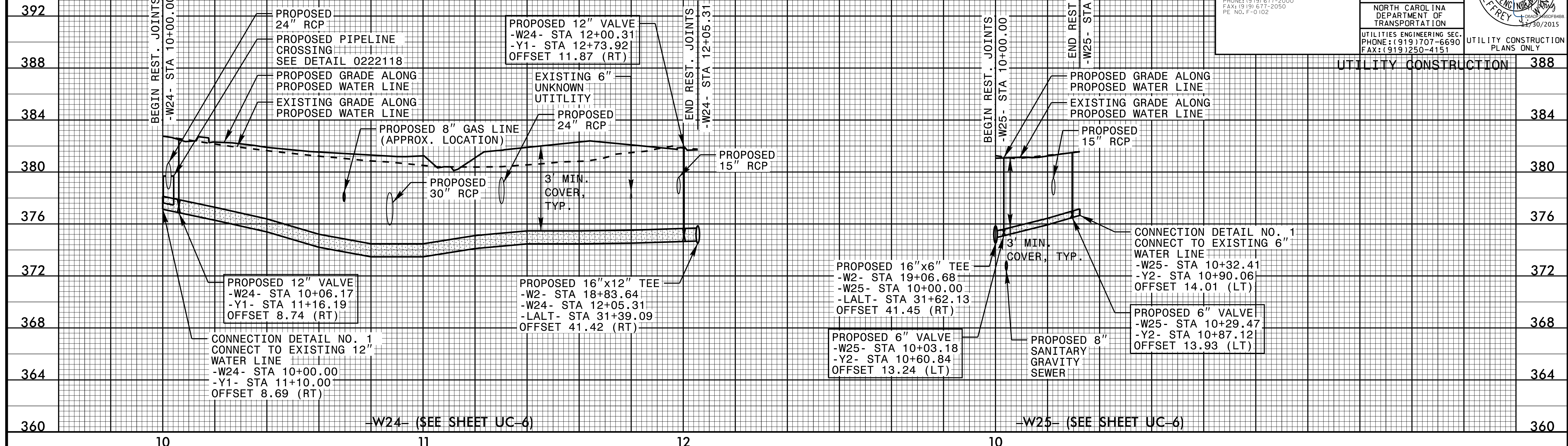

5/28/99

5/28/99

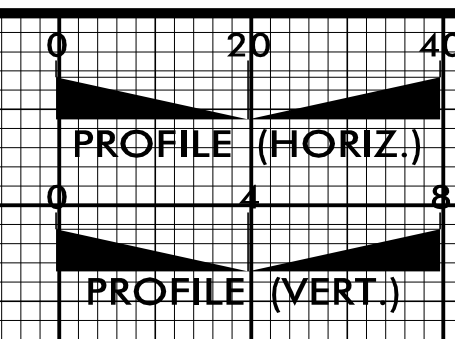

PROJECT REFERENCE NO. U-3308 SHEET NO. UC-39

DESIGNED BY: DGB
 DRAWN BY: JGB
 CHECKED BY: KFC
 APPROVED BY: JJW

REVISED:

NORTH CAROLINA DEPARTMENT OF TRANSPORTATION

UTILITIES ENGINEERING SEC. PHONE: (919) 707-6690 FAX: (919) 250-4151

UTILITY CONSTRUCTION PLANS ONLY

Kimley»Horn

P.O. BOX 33068 RALEIGH, NORTH CAROLINA 27636-3068
 PHONE: (919) 677-2000
 FAX: (919) 677-2050
 PE NO. P-0102

NORTH CAROLINA PROFESSIONAL SEAL
 030056
 JEFFREY J. JEFFREY
 11/30/2015

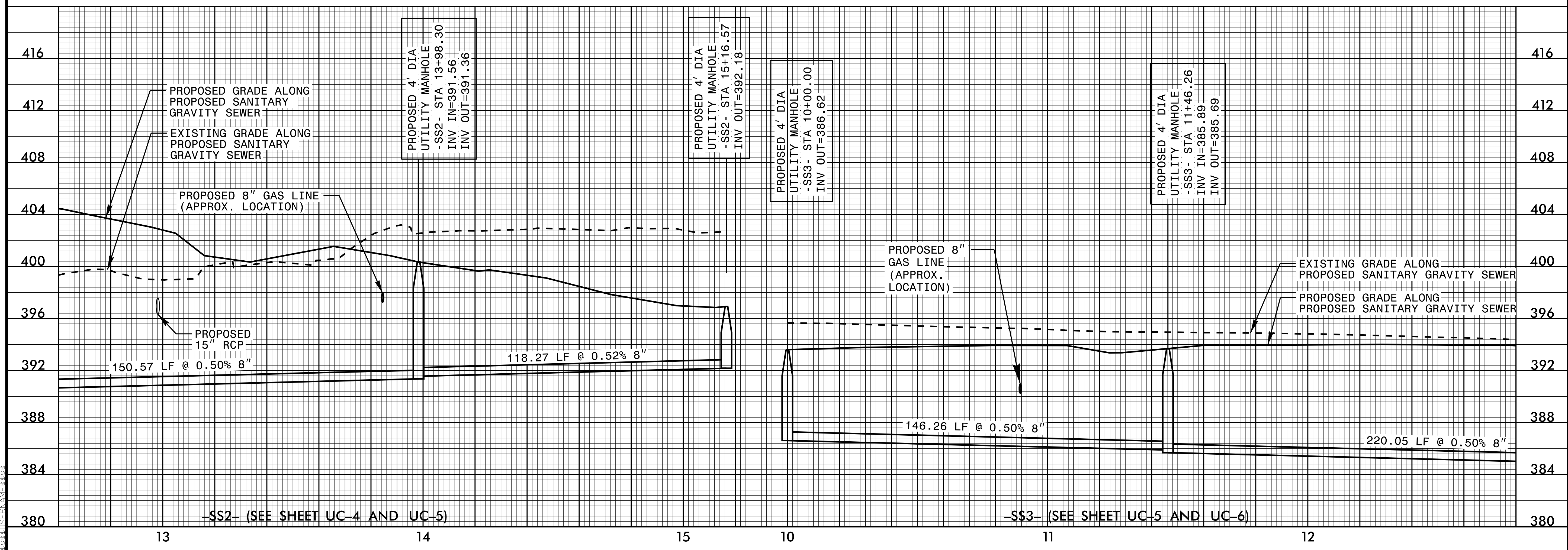
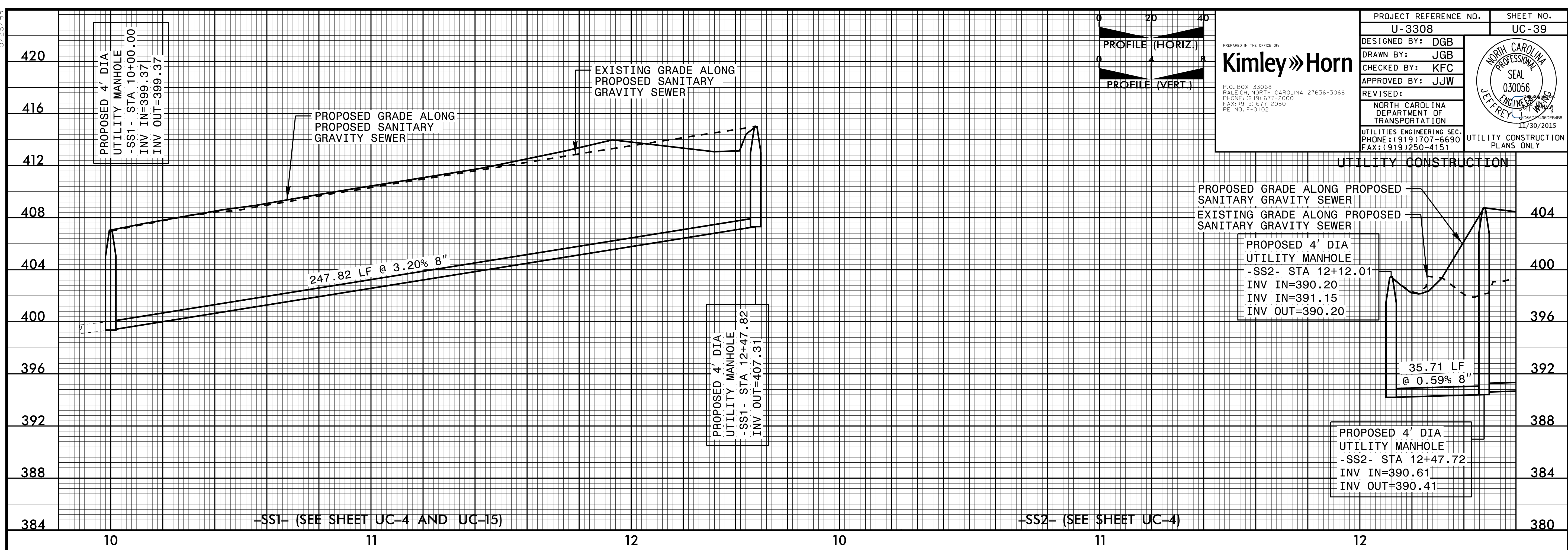

5/28/99

5/28/99

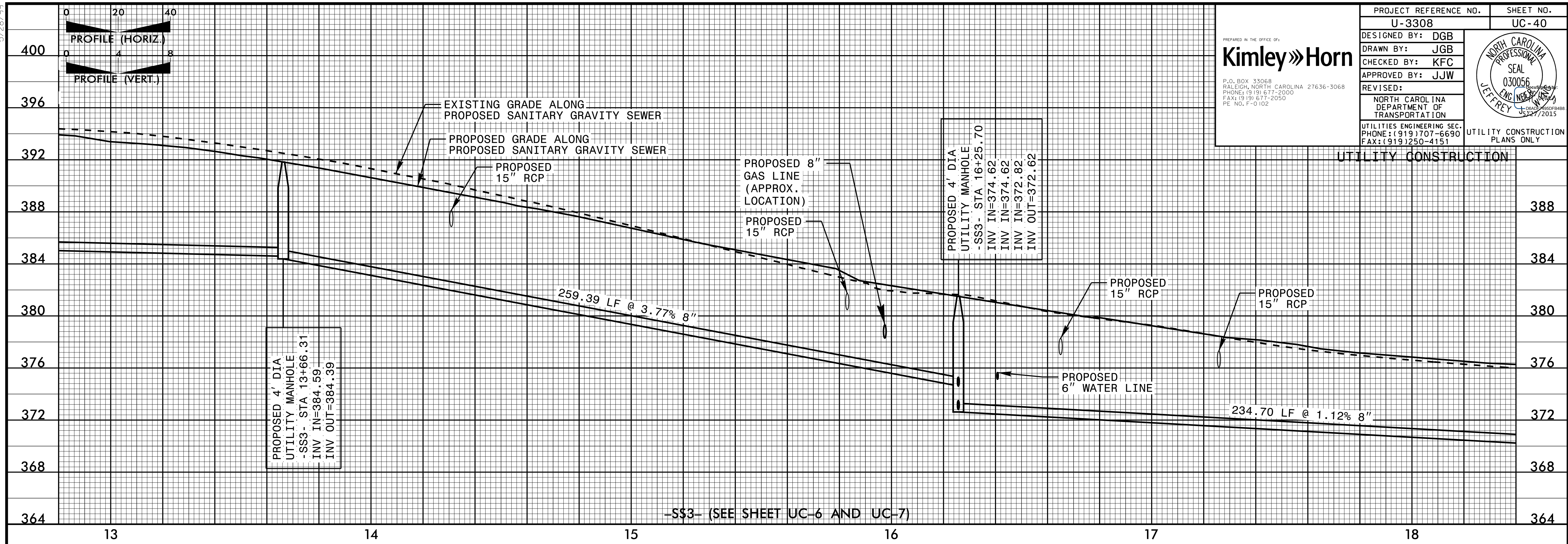

PROJECT REFERENCE NO. U-3308 SHEET NO. UC-40

DESIGNED BY: DGB

DRAWN BY: JGB

CHECKED BY: KFC

APPROVED BY: JJW

REVISED:

NORTH CAROLINA DEPARTMENT OF TRANSPORTATION

UTILITIES ENGINEERING SEC. PHONE: (919) 707-6690 FAX: (919) 250-4151

UTILITY CONSTRUCTION PLANS ONLY

Kimley»Horn

PREPARED IN THE OFFICE OF:

P.O. BOX 33068 RALEIGH, NORTH CAROLINA 27636-3068 PHONE: (919) 677-2000 FAX: (919) 677-2050 PE NO. F-0102

NORTH CAROLINA PROFESSIONAL SEAL 030056 JEFFREY J. DAVIS 650788 5/27/2015

5/28/99

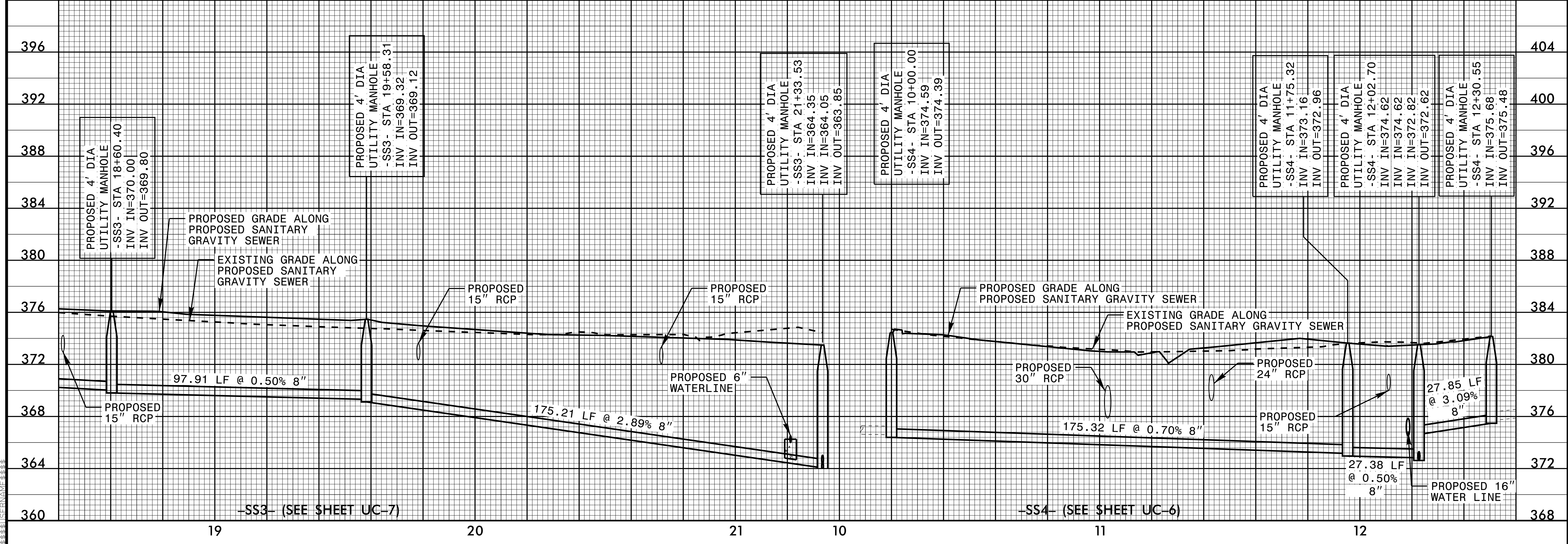

5/28/99

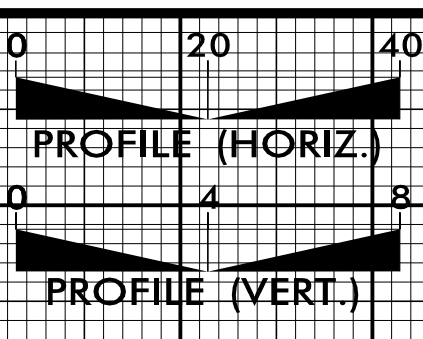

PROJECT REFERENCE NO. U-3308	SHEET NO. UC-41
DESIGNED BY: DGB	
DRAWN BY: JGB	
CHECKED BY: KFC	
APPROVED BY: JJW	REVISED:
NORTH CAROLINA DEPARTMENT OF TRANSPORTATION UTILITIES ENGINEERING SEC. PHONE: (919) 707-6690 FAX: (919) 250-4151	
UTILITY CONSTRUCTION PLANS ONLY	

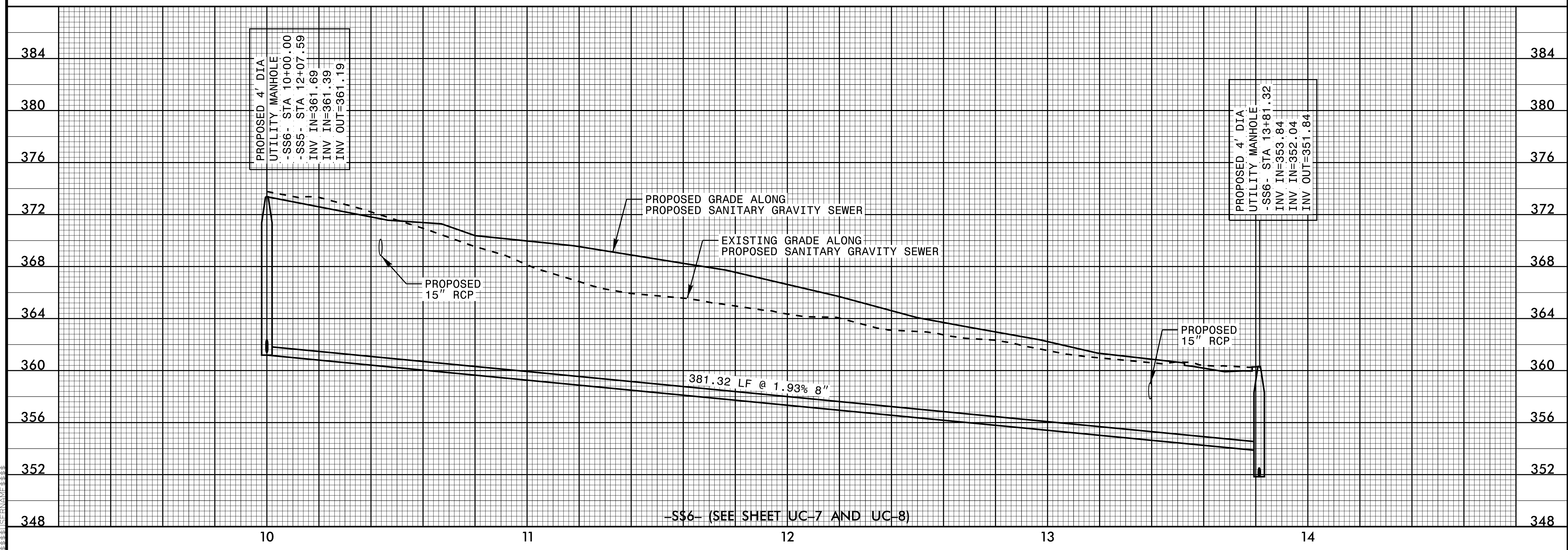
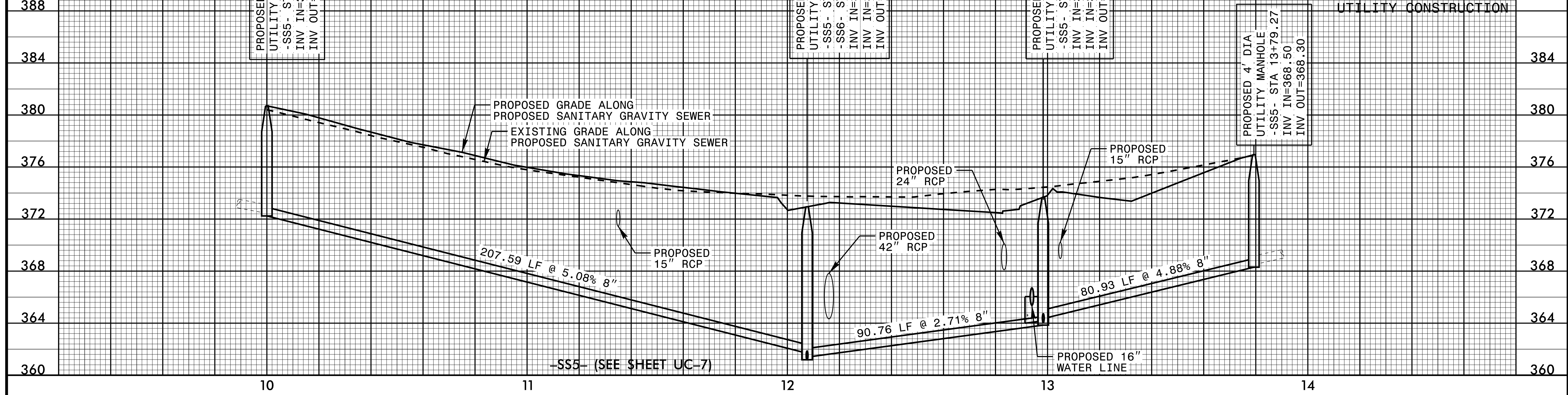

5/28/99

5/28/99

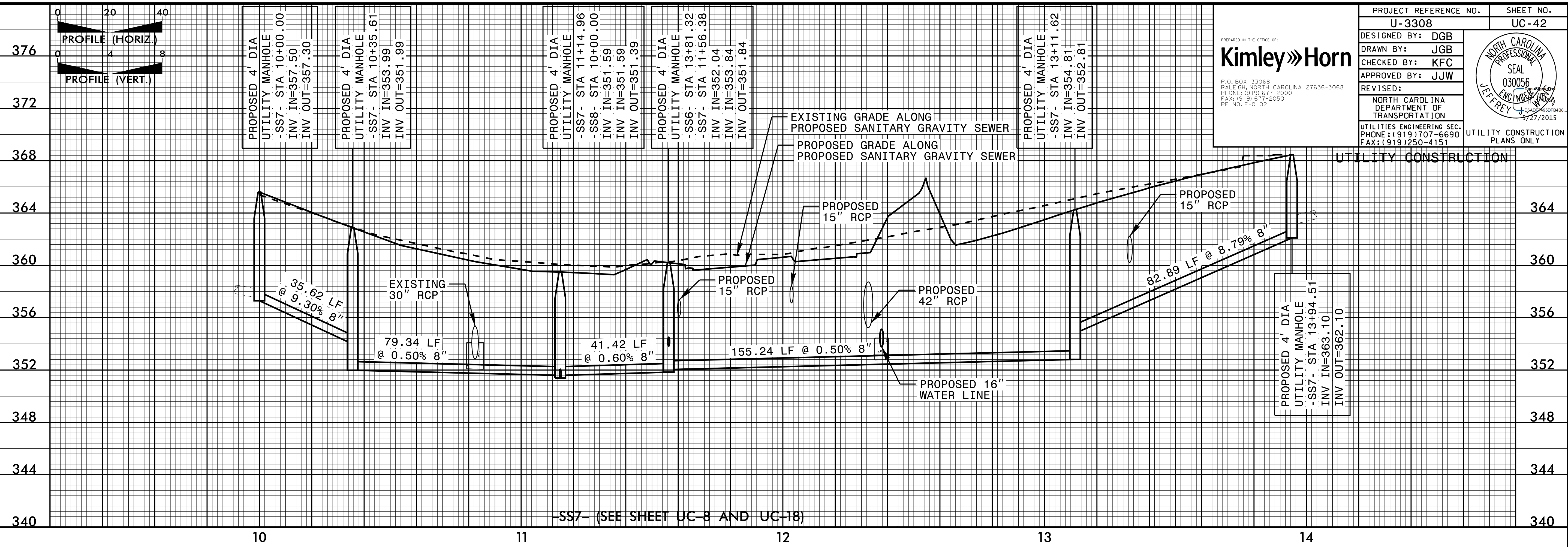
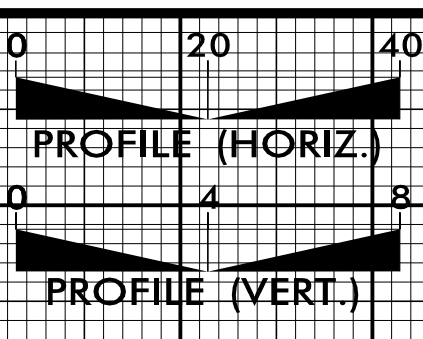

PROJECT REFERENCE NO. U-3308	SHEET NO. UC-42
DESIGNED BY: DGB	
DRAWN BY: JGB	
CHECKED BY: KFC	
APPROVED BY: JJW	REVISER:
NORTH CAROLINA DEPARTMENT OF TRANSPORTATION	
UTILITIES ENGINEERING SEC. PHONE: (919) 707-6690 FAX: (919) 250-4151	
UTILITY CONSTRUCTION PLANS ONLY	

Kimley»Horn

P.O. BOX 33068
RALEIGH, NORTH CAROLINA 27636-3068
PHONE: (919) 677-2000
FAX: (919) 677-2050
PE NO. P-0102

5/28/99

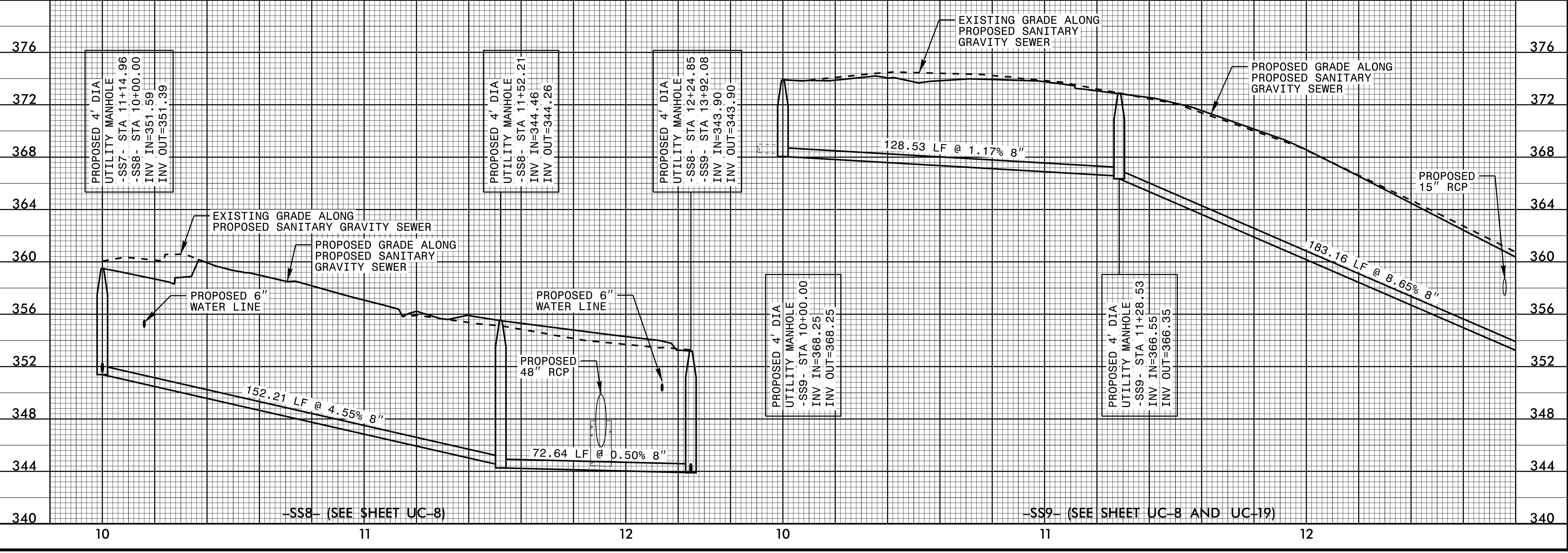

5/28/99

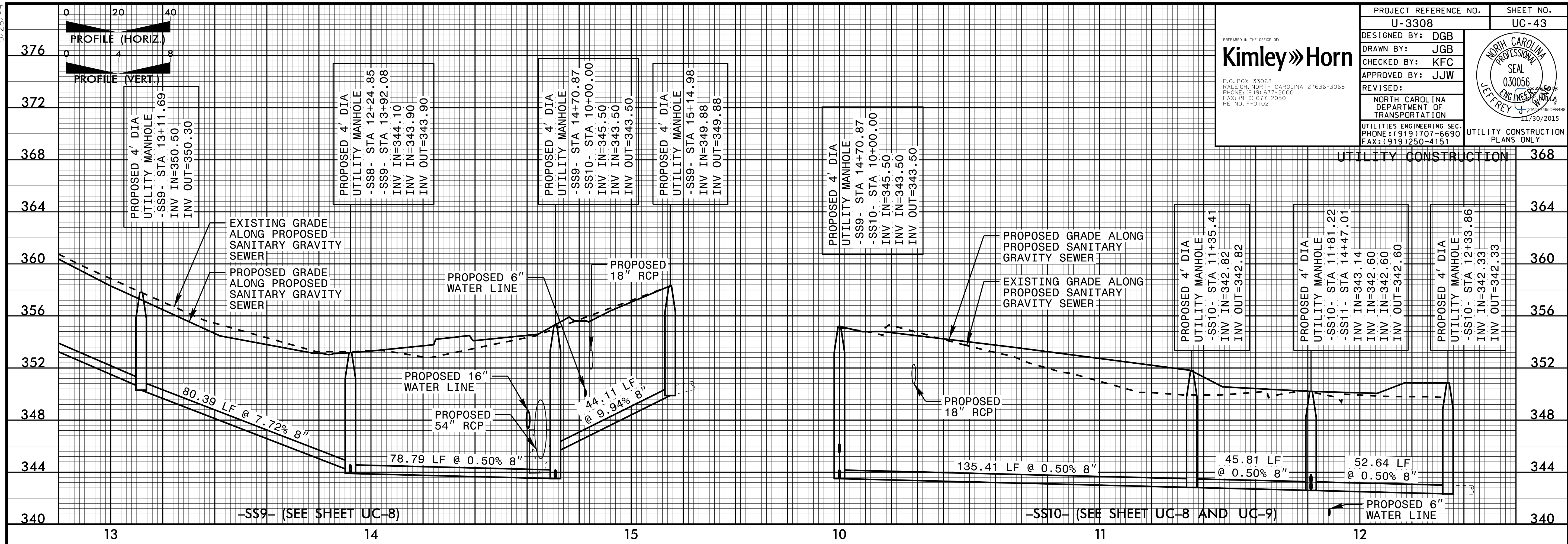

PROJECT REFERENCE NO. U-3308 SHEET NO. UC-43

DESIGNED BY: DGB
DRAWN BY: JGB
CHECKED BY: KFC
APPROVED BY: JJW

REVIS: NORTH CAROLINA DEPARTMENT OF TRANSPORTATION

UTILITIES ENGINEERING SEC. PHONE: (919) 707-6690 FAX: (919) 250-4151

UTILITY CONSTRUCTION PLANS ONLY

Kimley Horn
P.O. BOX 33068
RALEIGH, NORTH CAROLINA 27636-3068
PHONE: (919) 677-2000
FAX: (919) 677-2050
PE NO. P-0102

NORTH CAROLINA PROFESSIONAL SEAL
030056
JEFFREY J. HORN
11/30/2015

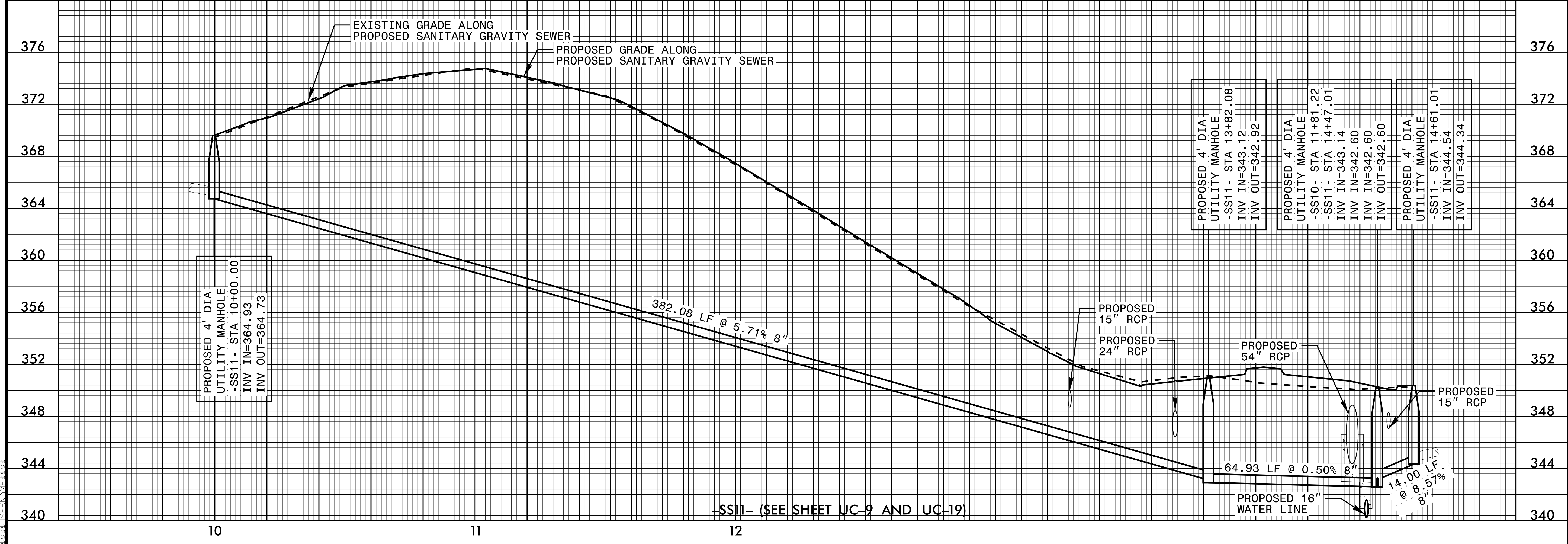

5/28/99

5/28/99

DESIGNED BY: DGB
 DRAWN BY: JGB
 CHECKED BY: KFC
 APPROVED BY: JJW

REVISIONS:

NORTH CAROLINA DEPARTMENT OF TRANSPORTATION

UTILITIES ENGINEERING SEC. PHONE: (919) 707-6690 FAX: (919) 250-4151

UTILITY CONSTRUCTION PLANS ONLY

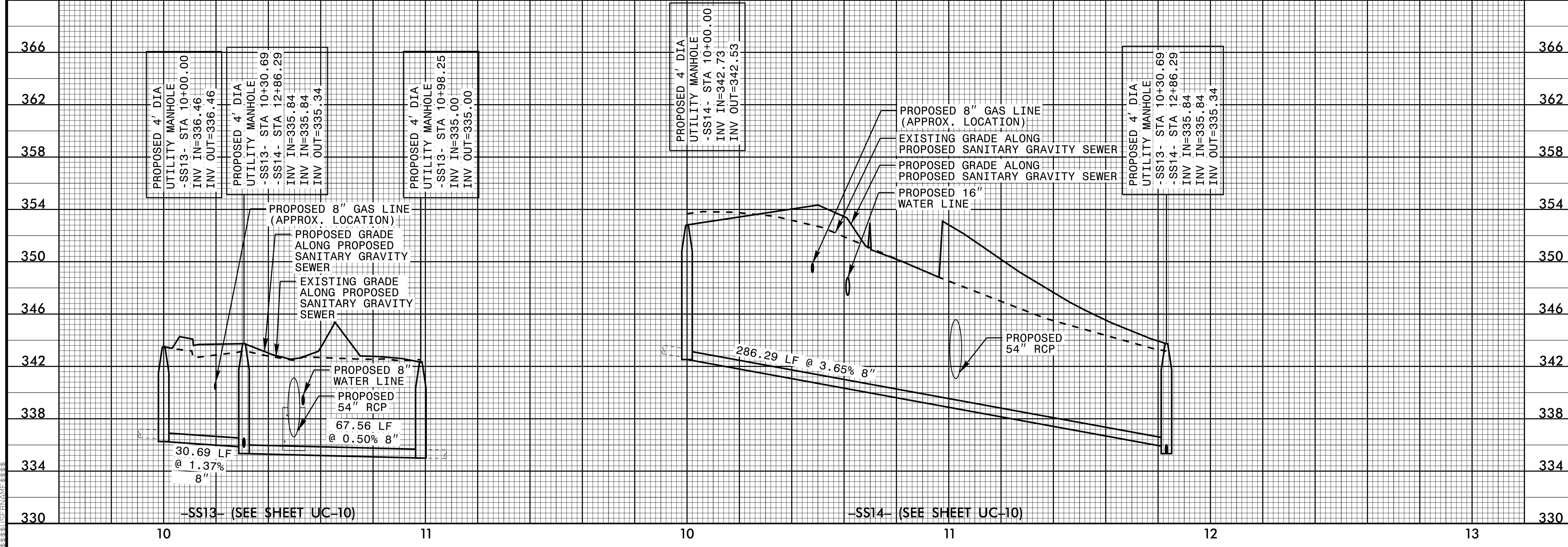
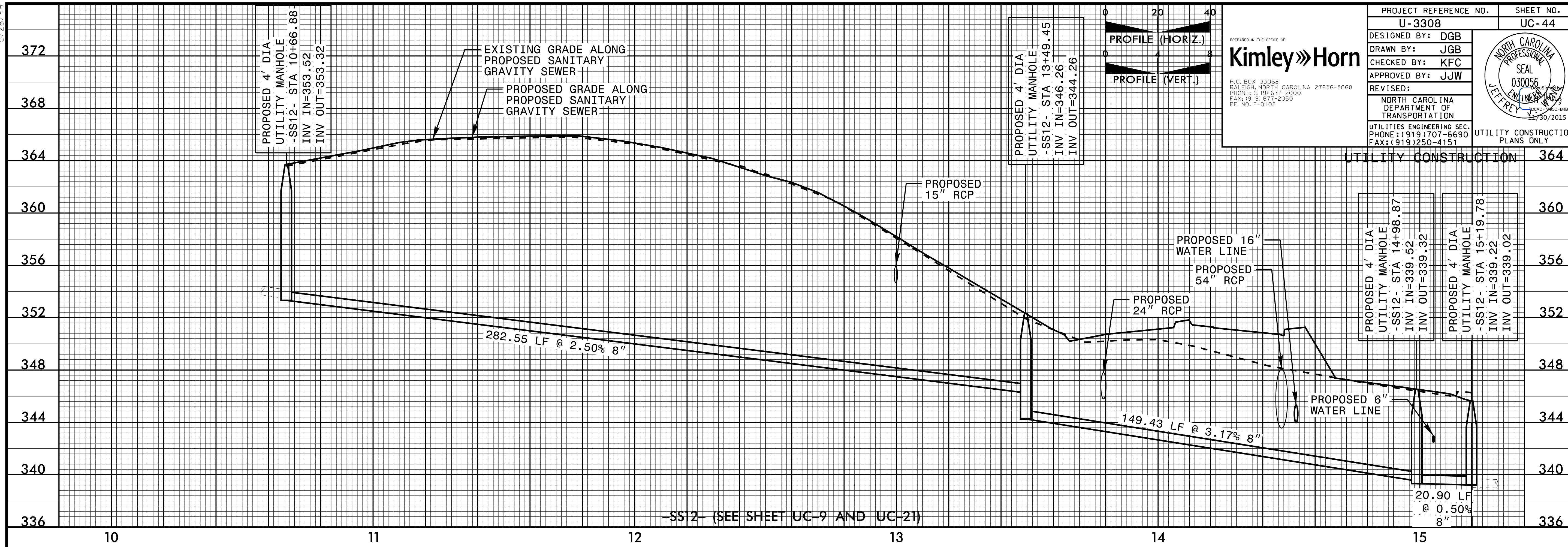
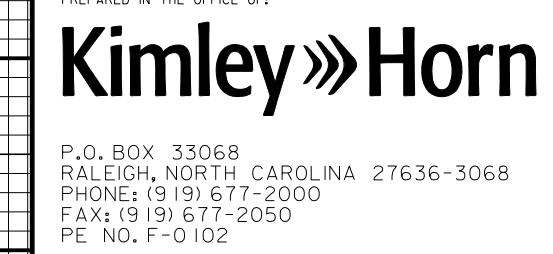

5/28/99

5/28/99

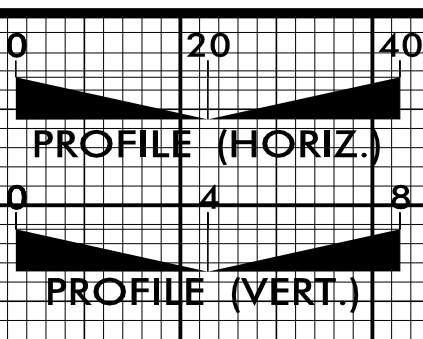

PROJECT REFERENCE NO. U-3308	SHEET NO. UC-45
DESIGNED BY: DGB	
DRAWN BY: JGB	
CHECKED BY: KFC	
APPROVED BY: JJW	
REVISED:	NORTH CAROLINA DEPARTMENT OF TRANSPORTATION UTILITIES ENGINEERING SEC. PHONE: (919) 707-6690 FAX: (919) 250-4151
UTILITY CONSTRUCTION PLANS ONLY	

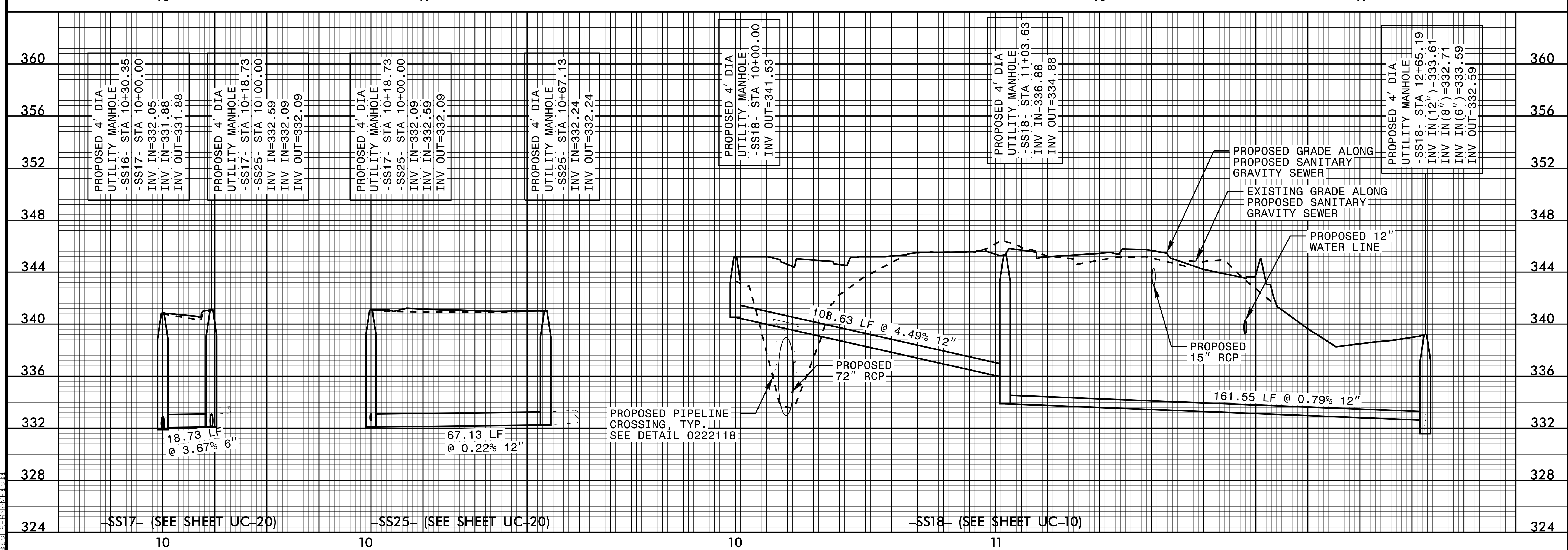
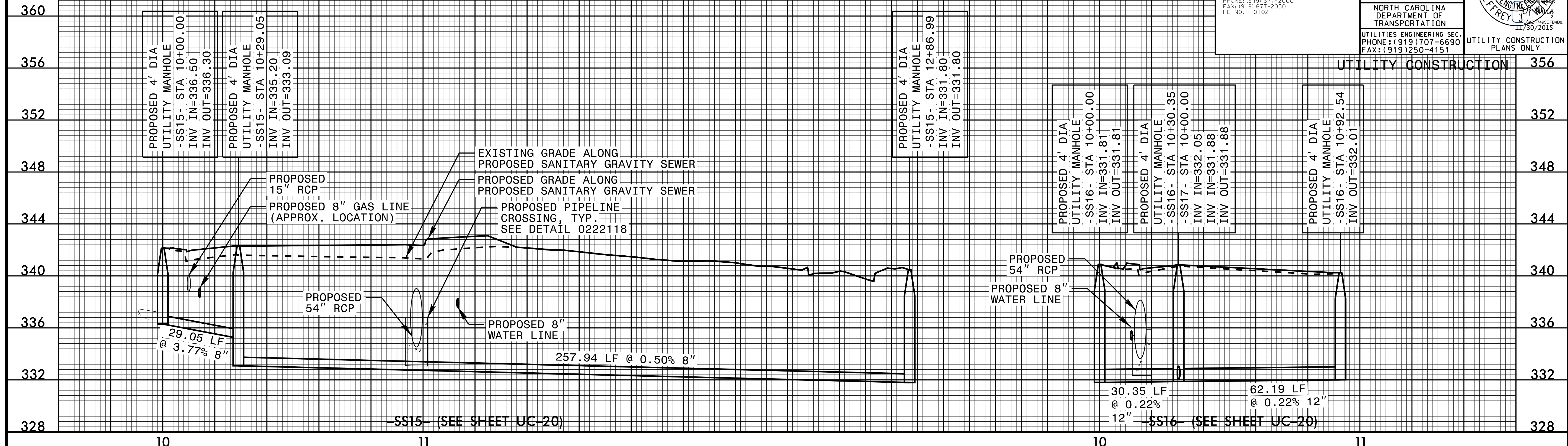

5/28/99

5/28/99

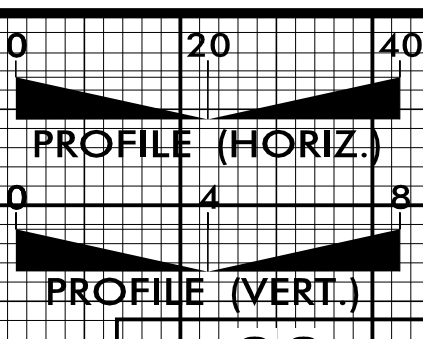

PROJECT REFERENCE NO. U-3308	SHEET NO. UC-46
DESIGNED BY: DGB	
DRAWN BY: JGB	
CHECKED BY: KFC	
APPROVED BY: JJW	REVIS: NORTH CAROLINA DEPARTMENT OF TRANSPORTATION
UTILITIES ENGINEERING SEC. PHONE: (919) 707-6690 FAX: (919) 250-4151	

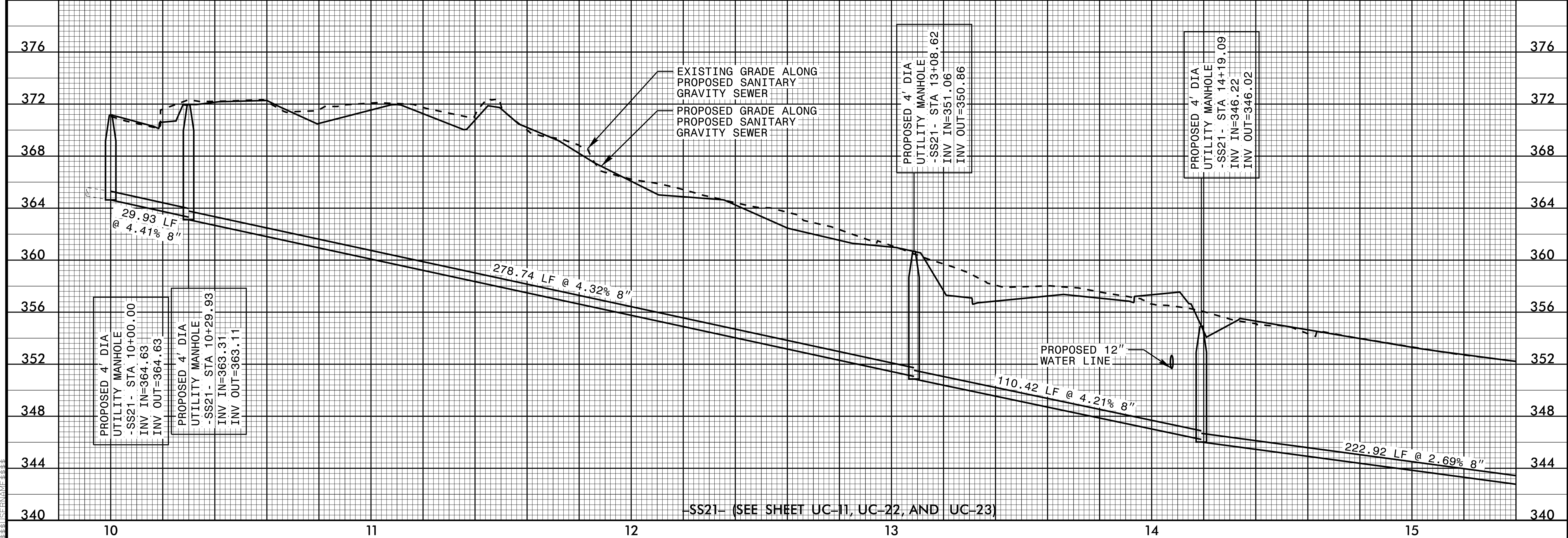
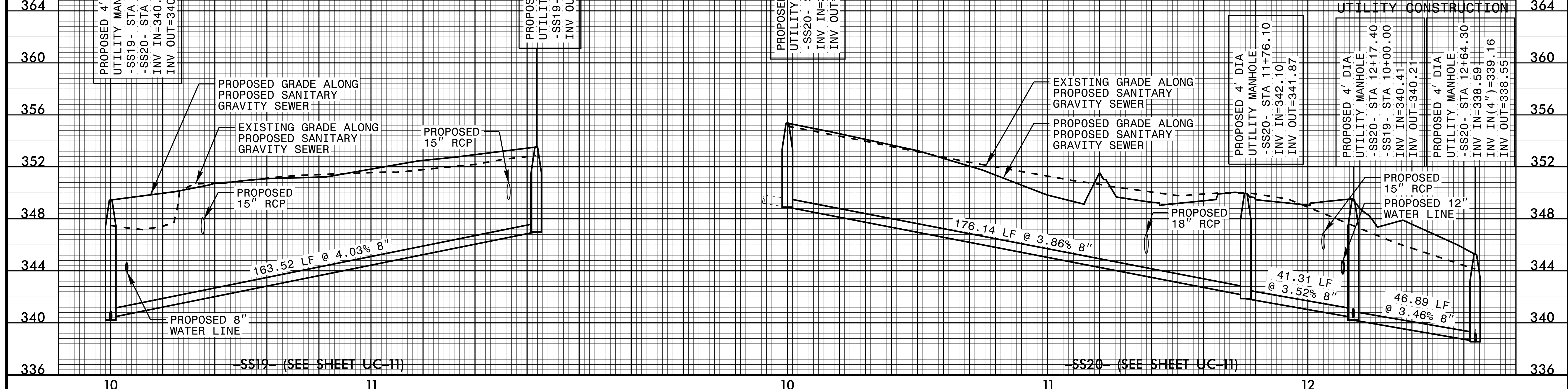

5/28/99

5/28/99

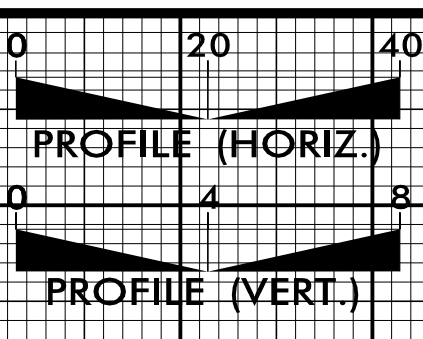

PROJECT REFERENCE NO. U-3308	SHEET NO. UC-47
DESIGNED BY: DGB	
DRAWN BY: JGB	
CHECKED BY: KFC	
APPROVED BY: JJW	
REVISED:	NORTH CAROLINA DEPARTMENT OF TRANSPORTATION UTILITIES ENGINEERING SEC. PHONE: (919) 707-6690 FAX: (919) 250-4151
PREPARED IN THE OFFICE OF: Kimley»Horn P.O. BOX 33068 RALEIGH, NORTH CAROLINA 27636-3068 PHONE: (919) 677-2000 FAX: (919) 677-2050 PE NO. F-0102	
UTILITY CONSTRUCTION PLANS ONLY	

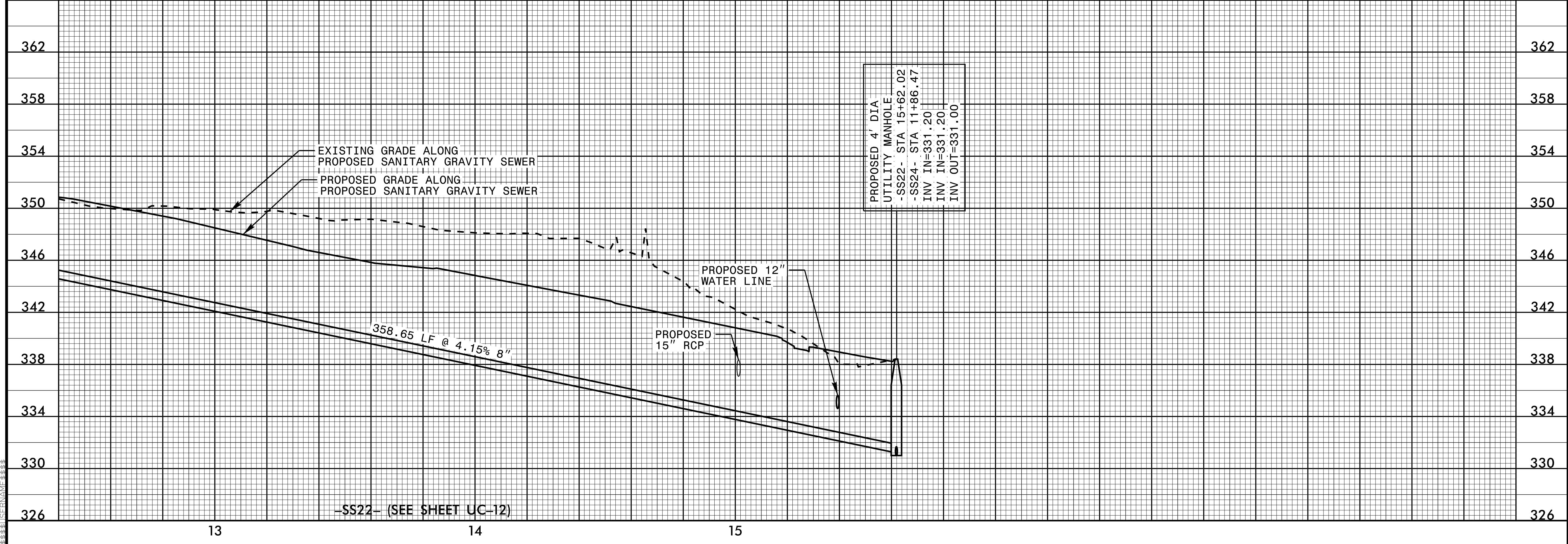
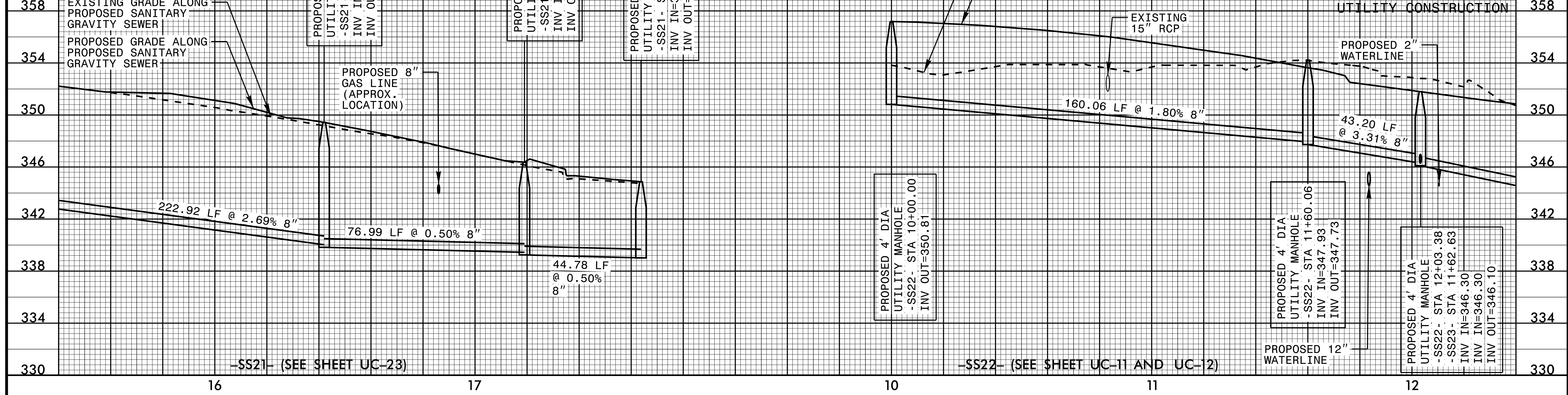

5/28/99

5/28/99

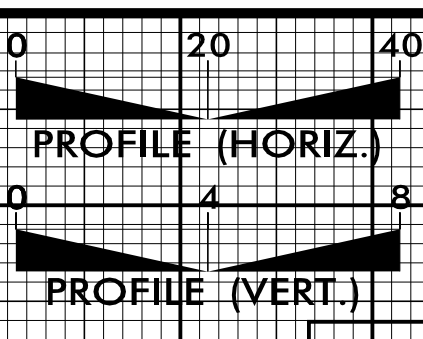

PROJECT REFERENCE NO. U-3308	SHEET NO. UC-48
DESIGNED BY: DGB	
DRAWN BY: JGB	
CHECKED BY: KFC	
APPROVED BY: JJW	REVISED:
NORTH CAROLINA DEPARTMENT OF TRANSPORTATION	
UTILITIES ENGINEERING SEC. PHONE: (919) 707-6690 FAX: (919) 250-4151	
UTILITY CONSTRUCTION PLANS ONLY	

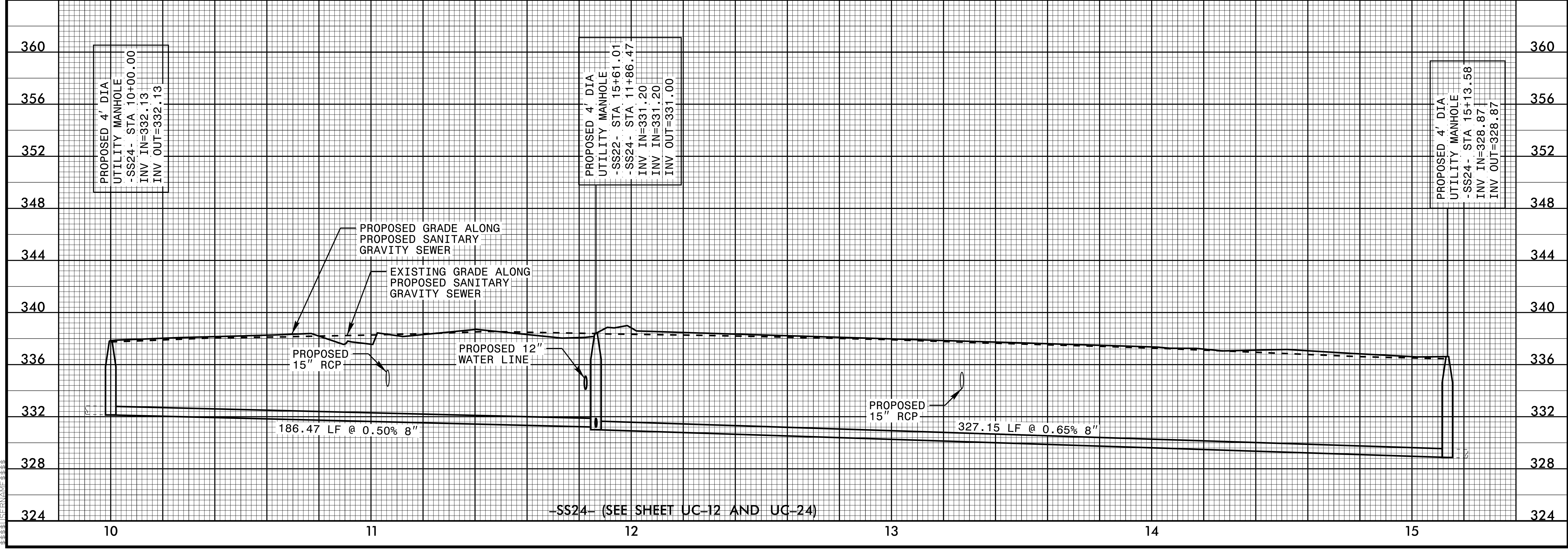
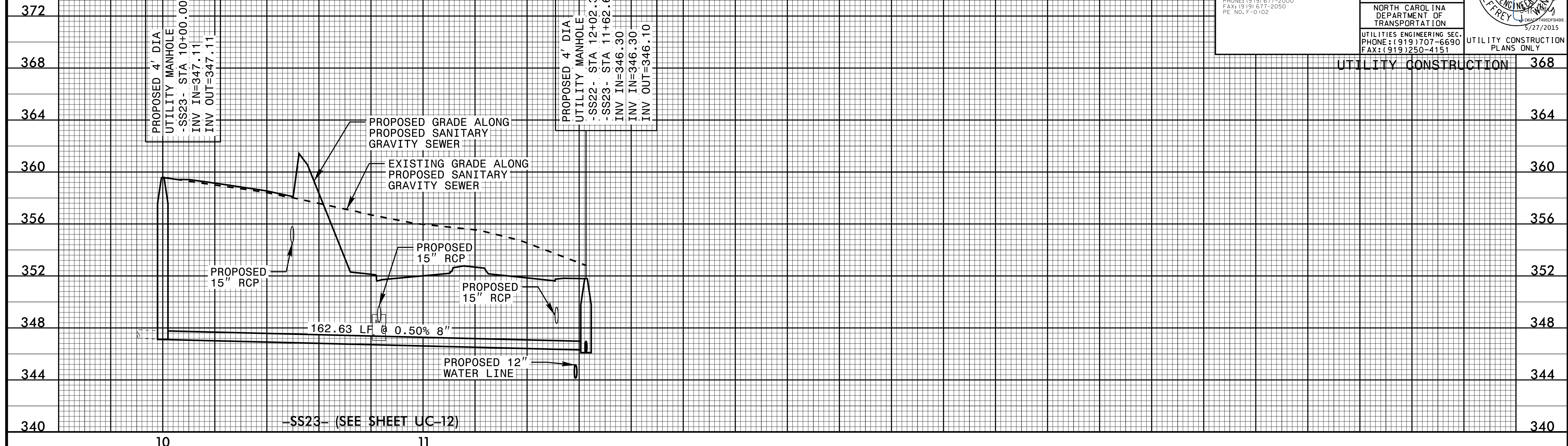

5/28/99

5/28/99

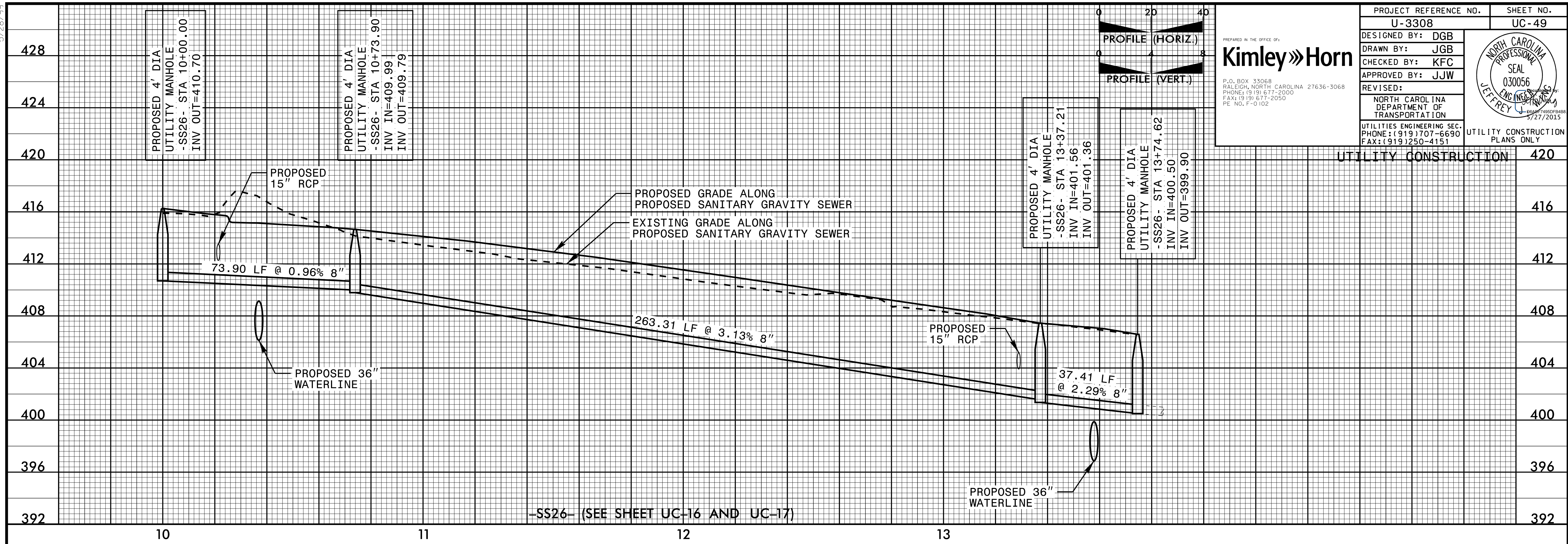

UTILITY CONSTRUCTION 420

PROJECT REFERENCE NO. U-3308	SHEET NO. UC-49
DESIGNED BY: DGB	
DRAWN BY: JGB	
CHECKED BY: KFC	
APPROVED BY: JJW	REVISED:
NORTH CAROLINA DEPARTMENT OF TRANSPORTATION	
UTILITIES ENGINEERING SEC. PHONE: (919) 707-6690 FAX: (919) 250-4151	
UTILITY CONSTRUCTION PLANS ONLY	

Kimley»Horn

P.O. BOX 33068
RALEIGH, NORTH CAROLINA 27636-3068
PHONE: (919) 677-2000
FAX: (919) 677-2050
PE NO. P-0102

5/28/99