

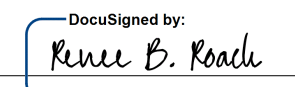

**STATE OF NORTH CAROLINA
DEPARTMENT OF TRANSPORTATION**

**SIGNING PLAN
DURHAM COUNTY**

**LOCATION: NC 55 (ALSTON AVE) FROM NC 147 (I.L."BUCK" DEAN FREEWAY) TO
NORTH OF US 70 BUS /NC 98 (HOLLOWAY ST)**

PROJECT REFERENCE NO. U-3308	SHEET NO. SIGN-1
APPROVED:  B306067CF4640D	
DATE: 3/27/2017	
SEAL 	
DOCUMENT NOT CONSIDERED FINAL UNLESS ALL SIGNATURES COMPLETED	

THIS DOCUMENT ORIGINALLY
ISSUED AND SEALED BY
RONALD W. KING
022959
ON 4-06-15

3-20-17 - ADDED NOTES, QUANTITY ITEMS, ROADWAY STANDARD
DRAWING REFERENCES, AND SIGNING SHEETS PER DIVISION
REQUEST. THERE IS A "*" LOCATED BY CHANGED ITEMS.

ROADWAY STANDARD DRAWING

THE FOLLOWING ROADWAY STANDARDS AS APPEAR IN "ROADWAY STANDARD DRAWINGS" -
PROJECT SERVICES UNIT - N.C. DEPARTMENT OF TRANSPORTATION - RALEIGH, N.C.,
DATED JANUARY 2012 ARE APPLICABLE TO THIS PROJECT AND BY REFERENCE HEREBY ARE
CONSIDERED A PART OF THESE PLANS:

STD. NO.	TITLE
* 901.10	TYPE 'A' SIGNS
901.50	ARROWS AND SHIELDS
* 901.70	SIGN STRINGERS AND SUPPORT SPACING
* 901.80	SIGN MOUNTING DETAILS - FOR TYPE A AND TYPE B SIGNS
* 903.10	GROUND MOUNTED SIGN SUPPORTS
* 904.10	ORIENTATION OF GROUND MOUNTED SIGNS
* 904.20	SECONDARY SIGN MOUNTING
904.50	MOUNTING OF TYPE 'D', 'E' AND 'F' SIGNS ON 'U' CHANNEL POSTS

GENERAL NOTES

- . SIGNS FURNISHED BY STATE
- . ALL EXISTING SIGNS/SIGN SYSTEM WITHIN THE PROJECT LIMITS SHALL BE REMOVED AND DISPOSED OF UNLESS OTHERWISE NOTED ON PLANS. THE SIGNS TO BE DISPOSED ARE NOT SHOWN ON THE PLAN; HOWEVER THE PAY ITEM/QUANTITY IS INCLUDED IN THE CONTRACT.
- *. CONFIRM IN WRITING AT LEAST 4 MONTHS IN ADVANCE, THE ACTUAL DATE THE DEPARTMENT FURNISHED SIGNS WILL BE REQUIRED.
- . ALL TYPE 'D' SIGNS SHALL BE MOUNTED ON TWO U-CHANNEL POSTS UNLESS OTHERWISE INDICATED ON THE PLANS.
- . IF REMOVAL OR RELOCATION OF SIGNS ON PRIVATE STREET (NON-STATE MAINTAINED) IS REQUIRED DUE TO CONSTRUCTION, THE CONTRACTOR SHALL INFORM THE ENGINEER. THE WORK WILL BE COMPLETED BY OTHERS.
- . WHEN NOT STATIONED OR DIMENSIONED ON PLANS, ALL 'E' AND 'F' SIGNS SHALL BE FIELD LOCATED BY THE ENGINEER
- . ALL EXISTING SIGNS ON "U" CHANNEL POST WITHIN THE PROJECT LIMITS SHALL BE REMOVED AND DISPOSED OF UNLESS OTHERWISE NOTED ON PLANS.
- . WHEN EXISTING SIGNS ARE REMOVED AND INSTALLED ON NEW SUPPORTS, THE RE-ERECTION SHALL IMMEDIATELY FOLLOW THE REMOVAL.
- . THE BACKGROUND FOR TYPE E & F SIGNS SHALL BE TYPE C REFLECTIVE SHEETING.
- *. DO NOT BEGIN FABRICATION FOR TYPES A & B SIGNS MOUNTED ON OVERHEAD STRUCTURES OR STEEL SUPPORTS UNTIL "S" DIMENSIONS HAVE BEEN FIELD VERIFIED.
- . SEE ROADWAY PLANS FOR GUARD/GUIDE RAIL DETAILS.

SUMMARY OF QUANTITIES

ITEM NO.	ITEM DESCRIPTION	QUANTITY	UNIT
DESC. NO.	SECT. NO.		
4048000000	902	1	C.Y. *
4066000000	903	284	LB. *
4072000000	903	2322	L.F.
4096000000	904	2	EA.
4102000000	904	141	EA.
4108000000	904	26	EA.
4110000000	904	2	EA. *
4152000000	907	1	EA. *
4155000000	907	86	EA.

PROJECT NOTES

- | | |
|---|-------------------------------------|
| 1 | DISPOSAL OF SIGN SYSTEM, U-CHANNEL |
| 2 | DISPOSAL OF SIGN SYSTEM, STEEL BEAM |

INDEX

SHEET NO.	DESCRIPTION
SIGN-1	TITLE SHEET
* SIGN-2-2D	E SHEET, SUPPORT INFORMATION SHEETS, AND A SHEET
SIGN-3	D & F SHEET
SIGN-4-10	SIGNING PLAN SHEETS

PLAN PREPARED BY: N.C.D.O.T. SIGNING AND DELINEATION UNIT

RENEE B. ROACH, P.E. STATE SIGNING & DELINEATION ENGINEER
STACEY W. JOHNS SIGNING & DELINEATION PROJECT DESIGN ENGINEER

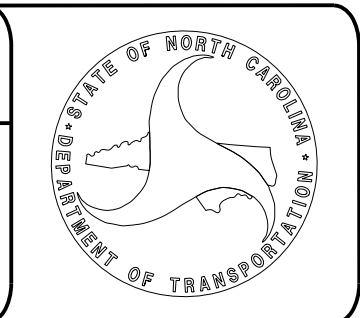

T.I.P.: U-3308

CONTRACT: C203567



401 QUANTITY REQ'D 1

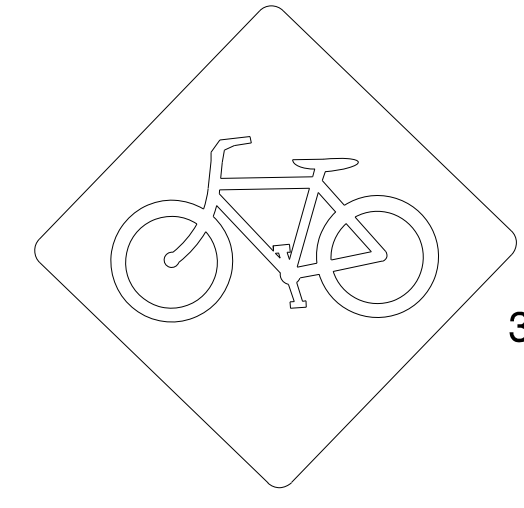

30 x 30
W11-1

ONE "U" POST PER SIGN

406 QUANTITY REQ'D 4



54 X 18
R6-1 (L)

MOUNT BACK TO BACK WITH SIGN 405
IN 2 INSTALLATION

411 QUANTITY REQ'D 2



36 X 36
R1-5R

ONE "U" POST PER SIGN

416 QUANTITY REQ'D 1



24 X 8
R3-17bP

MOUNT BELOW SIGN 415
IN 2 INSTALLATIONS

421 QUANTITY REQ'D 6



36 X 36
S1-1

YELLOW/GREEN REFLECTIVE SHEETING

ONE "U" POST PER SIGN

426 QUANTITY REQ'D 4

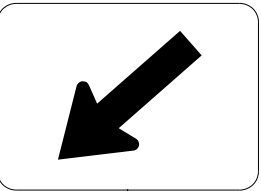

24 X 12
W16-7p

MOUNT BELOW SIGN 421
IN 4 INSTALLATIONS

427 QUANTITY REQ'D 2

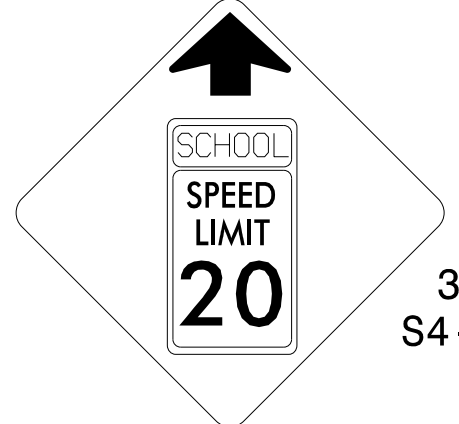

36 X 36
S4-5

ONE "U" POST PER SIGN

432 QUANTITY REQ'D 1

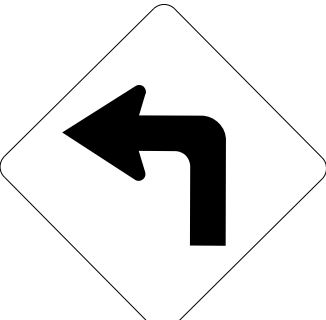

30 X 30
W1-1L

ONE "U" POST PER SIGN

402 QUANTITY REQ'D 1



18 x 24
W16-1P

MOUNT BELOW SIGN 401
IN 1 INSTALLATION

407 QUANTITY REQ'D 4



36 X 24
R5-1a

ONE "U" POST PER SIGN

412 QUANTITY REQ'D 10

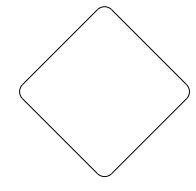

18 X 18
OM4-1

ONE "U" POST PER SIGN

417 QUANTITY REQ'D 12



36 X 12
R6-1 (R)

MOUNT ABOVE SIGN 409
IN 7 INSTALLATIONS

422 QUANTITY REQ'D 1

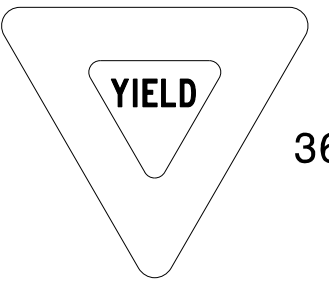

36 X 36 X 36
R1-2

ONE "U" POST PER SIGN

428 QUANTITY REQ'D 6



24 X 8
S4-3P

MOUNT ABOVE SIGN 421
IN 2 INSTALLATIONS
MOUNT ABOVE SIGN 420
IN 4 INSTALLATIONS

433 QUANTITY REQ'D 7

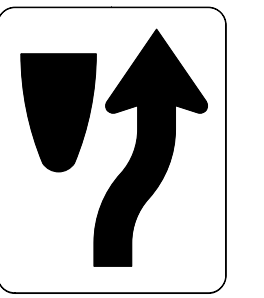

24 X 30
R4-7

ONE "U" POST PER SIGN

403 QUANTITY REQ'D 10



30 X 30
R5-1

MOUNT BACK TO BACK WITH SIGN 409
IN 2 INSTALLATION

408 QUANTITY REQ'D 1

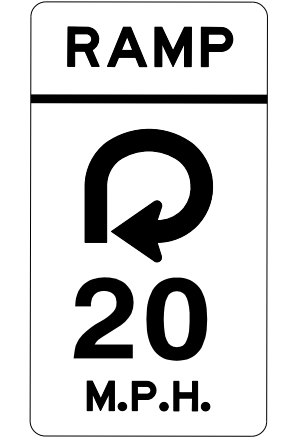

24 x 42
W13-7

ONE "U" POST PER SIGN

413 QUANTITY REQ'D 1

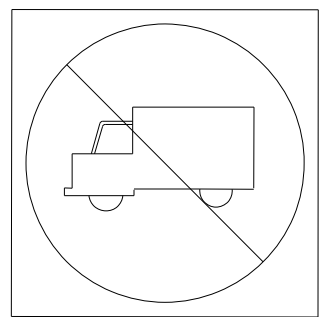

24 X 24
R5-2

ONE "U" POST PER SIGN

418 QUANTITY REQ'D 5

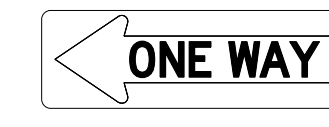

36 X 12
R6-1 (L)

MOUNT BACK TO BACK WITH
SIGN 417 IN 4 INSTALLATIONS

423 QUANTITY REQ'D 4

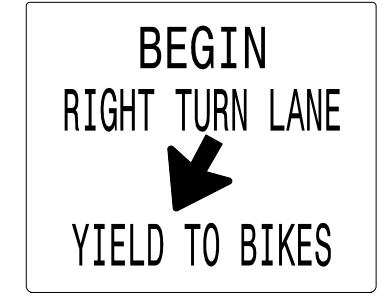

36 x 30
R4-4

ONE "U" POST PER SIGN

429 QUANTITY REQ'D 4

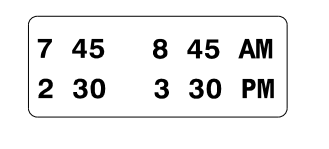

24 X 10
S4-1P

MOUNT BELOW SIGN 420
IN 4 INSTALLATIONS

434 QUANTITY REQ'D 6

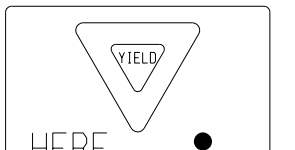

36 X 36
R1-5L

ONE "U" POST PER SIGN

404 QUANTITY REQ'D 2



18 X 18
W13-1P

MOUNT BELOW SIGN 431
IN 2 INSTALLATION

409 QUANTITY REQ'D 11

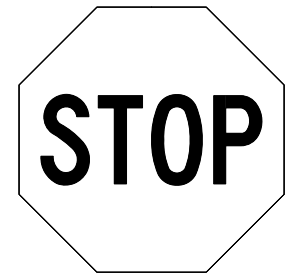

36 X 36
R1-1

ONE "U" POST PER SIGN

414 QUANTITY REQ'D 5



36 X 36
R3-7

ONE "U" POST PER SIGN

419 QUANTITY REQ'D 2



30 x 30
W14-2

ONE "U" POST PER SIGN

424 QUANTITY REQ'D 2



36 X 36
S4-5

ONE "U" POST PER SIGN

430 QUANTITY REQ'D 5

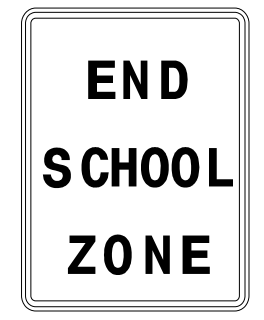

24 X 30
S5-2

ONE "U" POST PER SIGN

435 QUANTITY REQ'D 6

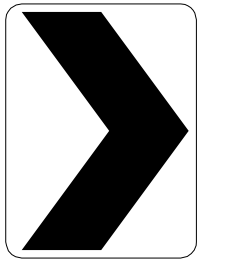

30 X 36
W1-8R

ONE "U" POST PER SIGN

405 QUANTITY REQ'D 3



54 X 18
R6-1 (R)

TWO "U" POSTS PER SIGN

410 QUANTITY REQ'D 3

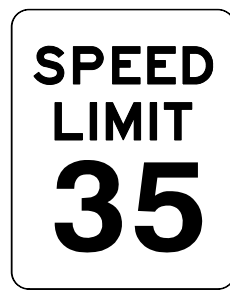

24 X 30
R2-1

ONE "U" POST PER SIGN

415 QUANTITY REQ'D 2



24 X 18
R3-17

ONE "U" POST PER SIGN

420 QUANTITY REQ'D 4



24 X 30
R2-1

ONE "U" POST PER SIGN

425 QUANTITY REQ'D 2

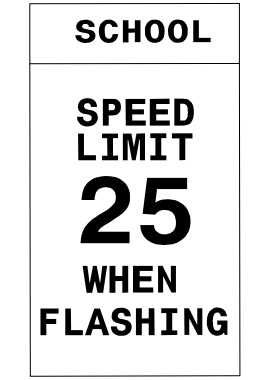

24 X 48
S5-1

ONE "U" POST PER SIGN

431 QUANTITY REQ'D 1

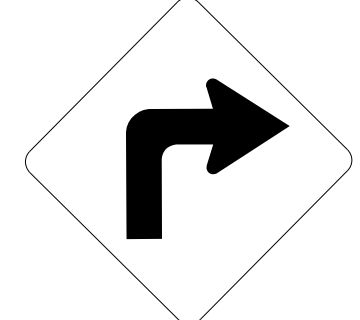

30 X 30
W1-1R

ONE "U" POST PER SIGN

TYPE "E" SIGNS

4/6/2015 P:\Projects-U\U3308-Traffic\Signing\CADD\Signing Layout Plans\U-3308-SGNSHT-1.dgn

3-22-17 - ADDED THIS SHEET.

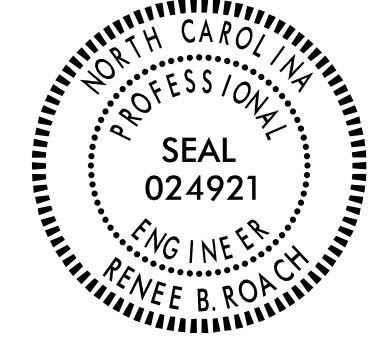
PROJECT REFERENCE NO. U-3308	SHEET NO. SIGN-2A
APPROVED: <i>Renee B. Roach</i> <small>DocuSigned by: Renee B. Roach B3C6C6F7CF4640D...</small>	
DATE: 3/27/2017	
SEAL	
	
DOCUMENT NOT CONSIDERED FINAL UNLESS ALL SIGNATURES COMPLETED	

Version: 3.0 Posted: 9/14/2016

NUMBER	TYPE	SIGN			ROADWAY STATION	NUMBER OF SUPPORTS	BEAM SECTION	SUPPORT TYPE BA or S	OMNI COUPLER	ATTACHMENT METHOD	MOUNTING METHOD	HORIZONTAL CLEARANCE* (ft.)	SUPPORT SPACING	LENGTH (ft)			LEFT SUPPORT (ft)			CENTER SUPPORT (ft)			RIGHT SUPPORT (ft)			SUPPORT WEIGHTS		FOOTINGS				FIELD VERIFIED SEE NOTE 2 (mm/dd/yy)
		SIZE (in.)												SNS HT	MTG HT	EMB-D-MENT	S	L	LENGTH	S	L	LENGTH	S	L	LENGTH	B/A (lbs.)	SIMPLE (lbs.)	DIAMETER (ft.)	DEPTH (ft.)	REINFORCED (c.y.)	PLAIN (c.y.)	
		w	x	h																												
101A	A	168	x	30		2	W6x9	S	N/A	1-R	N/A	16.88	8.79	6.00	7.00	3.5	-0.70	12.30	15.80	0.00	0.00	0.00	-0.80	12.20	15.70	0.00	283.5	1.5	4	0.52	0.00	3/20/2017
101B	A	180	x	72																												
														TOTAL			TOTAL			TOTAL				TOTAL								
														0.00			283.50			0.52				0.00								
														USE:			0.00			284.00			1.00				0.00					

NOTES

- DIMENSION "S" REPRESENTS AN INCREASE (+), OR A DECREASE (-) IN POLE LENGTH, RELATIVE TO THE ELEVATION OF THE EDGE OF TRAVEL LANE.
- FIELD VERIFICATIONS SHALL BE REQUIRED FOR ALL SUPPORTS, SEE (*) ARTICLE 903-3. FABRICATORS SHALL BE AISC CERTIFIED IN CATEGORY 1, SEE (*) ARTICLE 1072-1. (*) = N.C.D.O.T. STANDARD SPECIFICATIONS FOR ROADS AND STRUCTURES
- PLAN LOCATIONS FOR EXISTING UTILITIES ARE BASED ON THE BEST AVAILABLE INFORMATION AND, THEREFORE MAY NOT BE PRECISELY ACCURATE. THEREFORE, IT IS INCUMBENT UPON THE CONTRACTOR TO DETERMINE THE EXACT LOCATION OF UTILITIES BEFORE BEGINNING WORK IN A LOCATION.

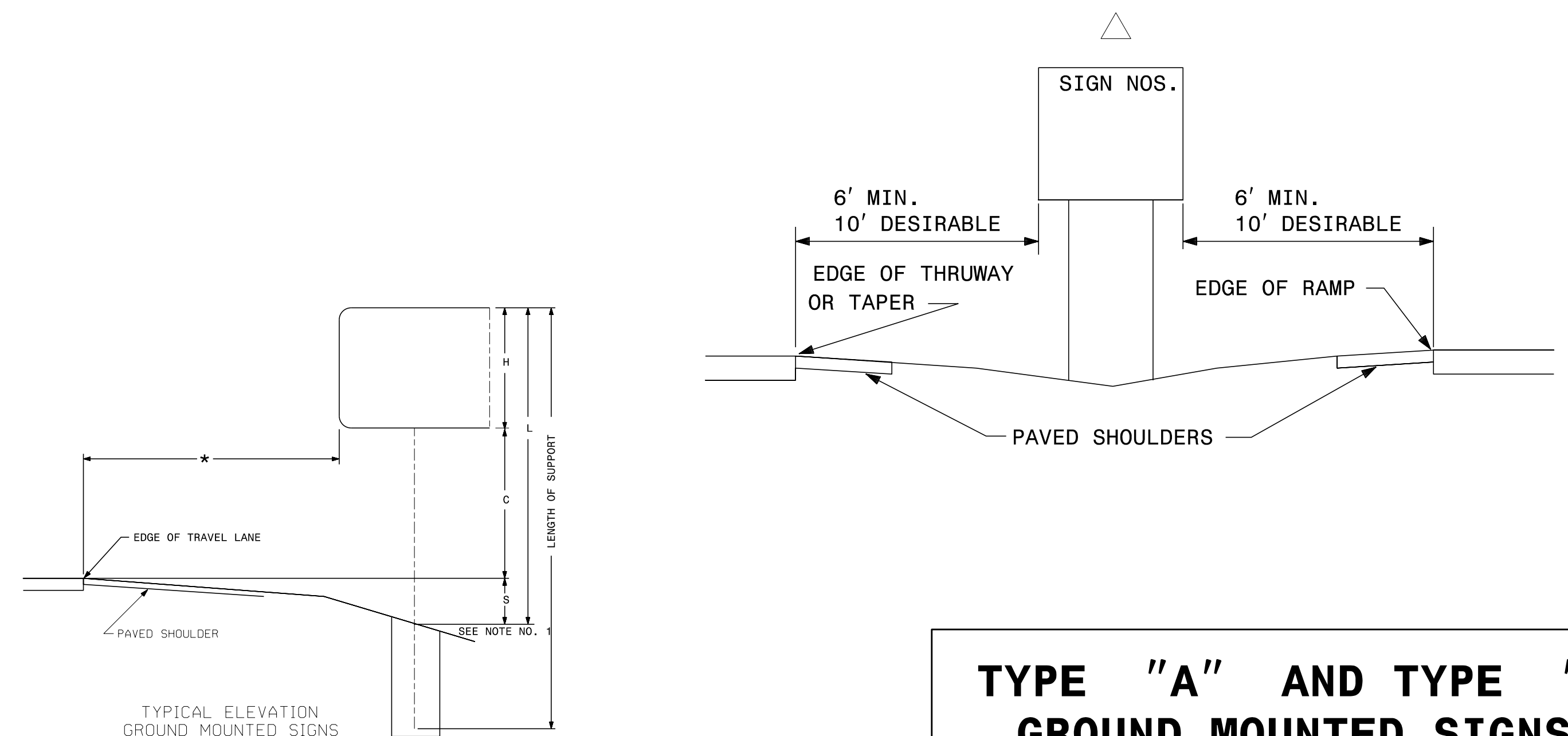

**TYPE "A" AND TYPE "B"
GROUND MOUNTED SIGNS**

3/27/2017 P:\TIP\Projects-U\U3308-Traffic\Signing\CADD\Signing Layout Plans\U-3308-SGNSHT-1-Revision.dgn

APPROVED: *Renee B. Roach*
DocuSigned by:
 Renee B. Roach
 B3C6C67CF4640D
 DATE: 3/27/2017

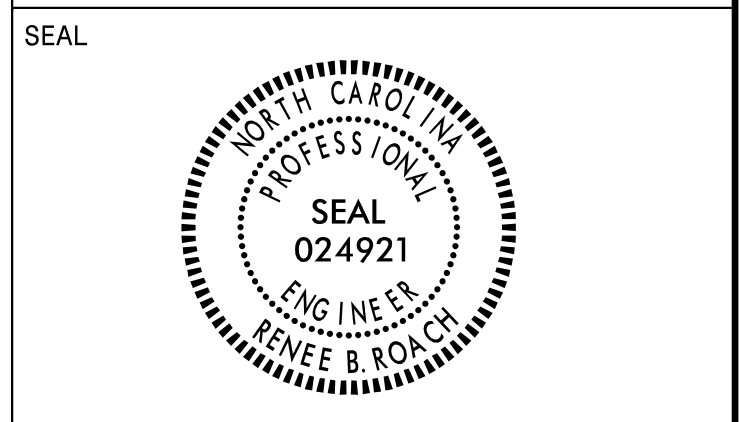

SEAL
**DOCUMENT NOT CONSIDERED FINAL
 UNLESS ALL SIGNATURES COMPLETED**

STATE OF NORTH CAROLINA
 DEPT. OF TRANSPORTATION
 DIVISION OF HIGHWAYS
 RALEIGH, N.C.

ENGLISH DETAIL DRAWING FOR
GROUND MOUNTED SIGN SUPPORTS

SHEET 2 OF 3
903D10

BEAM SHAPE	SLIP BASE PLATE DATA								KEEPER PLATE DATA								HINGE CONNECTION DATA								BREAK AWAY SUPPORT WEIGHT CONSTANT LBS.	
	BOLT SIZE	A ₁	B ₁	C ₁	D ₁	E ₁	T ₁	R ₁	A ₂	B ₂	C ₂	D ₂	E ₂	T ₂	R ₂	T ₂	BOLT SIZE	F	G	H	I	J	K	L		R ₃
S3X5.7	1/2" DIA. X 3 1/4"	7"	4"	1"	3/4"	2 1/2"	1"	9/32"	7"	4"	1"	3/4"	2 1/2"	9/32"	28 GAUGE	1/2" DIA. X 1 3/4"	2 1/4"	3 1/2"	4"	1/2"	1"	1/2"	2"	9/32"	3/8"	18
S4X7.7	1/2" DIA. X 3 1/4"	8"	4"	1"	3/4"	2 1/2"	1"	9/32"	8"	4"	1"	3/4"	2 1/2"	9/32"	28 GAUGE	1/2" DIA. X 1 3/4"	2 5/8"	3 1/2"	4"	1/2"	1"	1/2"	2"	9/32"	3/8"	20
W6X9	1/2" DIA. X 3 1/4"	10"	5"	1"	3/4"	3 1/2"	1"	9/32"	10"	5"	1"	3/4"	3 1/2"	9/32"	28 GAUGE	1/2" DIA. X 1 3/4"	4"	3 1/2"	4"	3/4"	1"	1/2"	2"	9/32"	3/8"	32
W6X12	5/8" DIA. X 4"	11"	5"	1 1/4"	7/8"	3 1/4"	1 1/4"	11/32"	11"	5"	1 1/4"	7/8"	3 1/4"	11/32"	28 GAUGE	5/8" DIA. X 2"	4"	4"	4 1/2"	3/4"	1 1/8"	5/8"	2 1/4"	11/32"	3/8"	39
W6X16	5/8" DIA. X 4 1/2"	12"	6"	1 1/4"	7/8"	4 1/4"	1 1/2"	11/32"	12"	6"	1 1/4"	7/8"	4 1/4"	11/32"	28 GAUGE	5/8" DIA. X 2 1/4"	4"	4"	4 1/2"	3/4"	1 1/8"	5/8"	2 1/4"	11/32"	1/2"	47
W8X18	5/8" DIA. X 4 1/2"	13 1/2"	6 1/2"	1 1/4"	7/8"	4 3/4"	1 1/2"	11/32"	13 1/2"	6 1/2"	1 1/4"	7/8"	4 3/4"	11/32"	28 GAUGE	5/8" DIA. X 2 1/4"	5 1/4"	4"	4 1/2"	1"	1 1/8"	5/8"	2 1/4"	11/32"	1/2"	70
W8X21	3/4" DIA. X 4 1/2"	14"	7"	1 1/2"	1"	5"	1 1/2"	13/32"	14"	7"	1 1/2"	1"	5"	13/32"	28 GAUGE	3/4" DIA. X 2 1/2"	5 1/4"	6"	7"	1"	1 3/4"	3/4"	3 1/2"	13/32"	1/2"	73
W10X22	3/4" DIA. X 4 1/2"	16"	8"	1 1/2"	1"	6"	1 1/2"	13/32"	16"	8"	1 1/2"	1"	6"	13/32"	28 GAUGE	3/4" DIA. X 2 1/2"	5 3/4"	6"	7"	1"	1 3/4"	3/4"	3 1/2"	13/32"	1/2"	119
W10X26	3/4" DIA. X 5 1/2"	16 1/2"	8"	1 1/2"	1"	6"	1 3/4"	13/32"	16 1/2"	8"	1 1/2"	1"	6"	13/32"	28 GAUGE	3/4" DIA. X 2 3/4"	5 3/4"	6"	7"	1"	1 3/4"	3/4"	3 1/2"	13/32"	5/8"	140
W12X26	3/4" DIA. X 5 1/2"	18 1/2"	9"	1 1/2"	1"	7"	1 3/4"	13/32"	18 1/2"	9"	1 1/2"	1"	7"	13/32"	28 GAUGE	3/4" DIA. X 2 3/4"	6 1/2"	6"	7"	1"	1 3/4"	3/4"	3 1/2"	13/32"	5/8"	176
W14X30	1" DIA. X 6"	22"	9"	2"	1 1/2"	6"	2"	17/32"	22"	9"	2"	1 1/2"	6"	17/32"	28 GAUGE	1" DIA. X 3"	6 3/4"	7"	8"	1 1/4"	2"	1"	4"	17/32"	5/8"	205
W16X31	1" DIA. X 6"	24"	9"	2"	1 1/2"	6"	2"	17/32"	24"	9"	2"	1 1/2"	6"	17/32"	28 GAUGE	1" DIA. X 3"	5 1/2"	7"	8"	1 1/4"	2"	1"	4"	17/32"	3/4"	223
W18X35	1" DIA. X 6"	25"	9"	2"	1 1/2"	6"	2"	17/32"	25"	9"	2"	1 1/2"	6"	17/32"	28 GAUGE	1" DIA. X 3"	6"	7"	8"	1 1/4"	2"	1"	4"	17/32"	3/4"	243
W18X40	1" DIA. X 6 1/2"	26"	9"	2"	1 1/2"	6"	2 1/4"	17/32"	26"	9"	2"	1 1/2"	6"	17/32"	28 GAUGE	1" DIA. X 3 1/2"	6"	7"	8"	1 1/4"	2"	1"	4"	17/32"	7/8"	278
W21X44	1" DIA. X 7"	29"	9"	2"	1 1/2"	6"	2 1/2"	17/32"	29"	9"	2"	1 1/2"	6"	17/32"	28 GAUGE	1" DIA. X 3 1/2"	6 1/2"	7"	8"	1 1/4"	2"	1"	4"	17/32"	7/8"	310

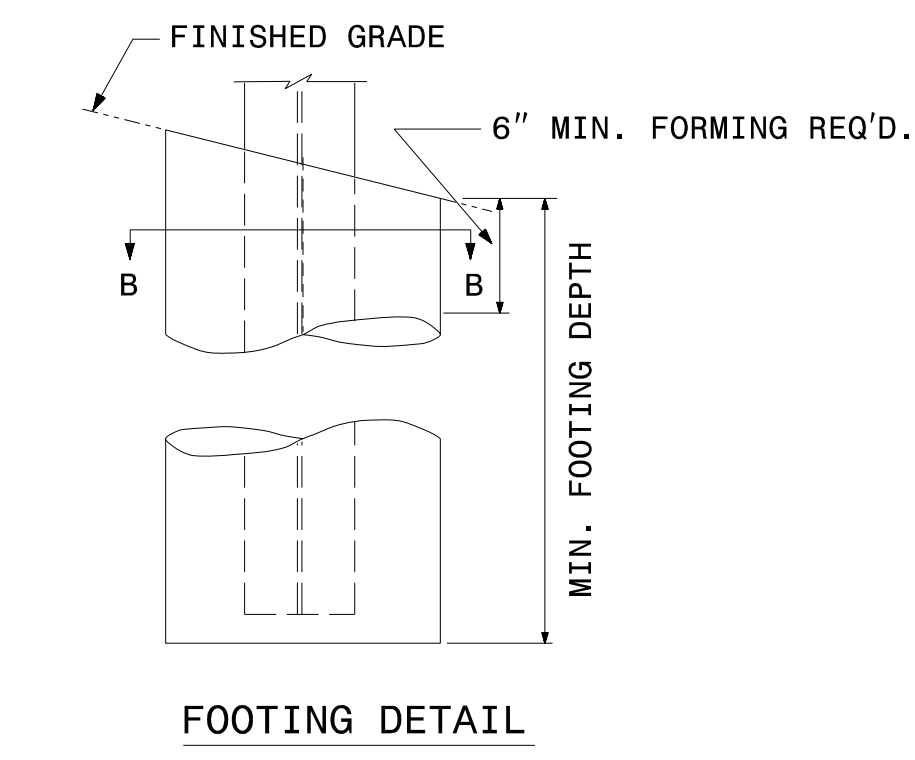
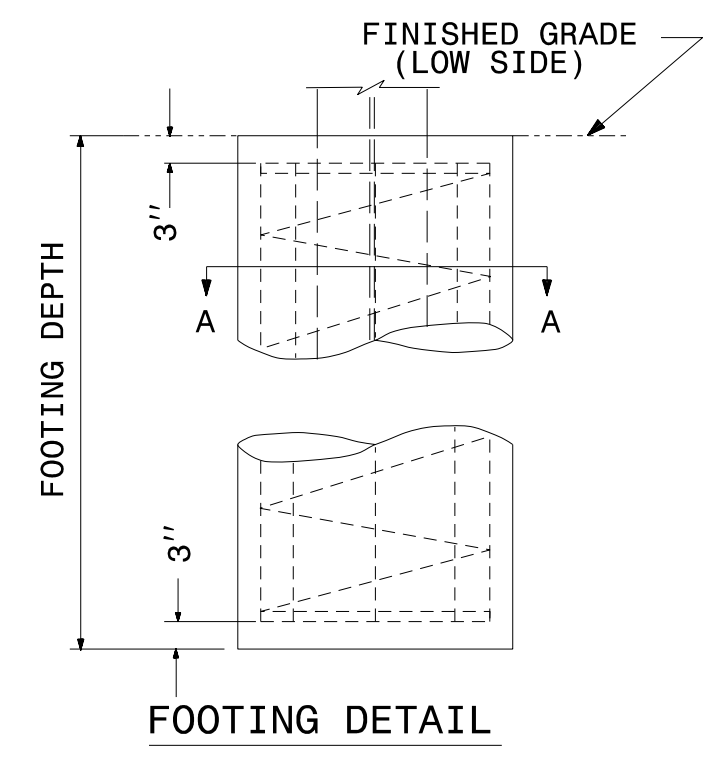
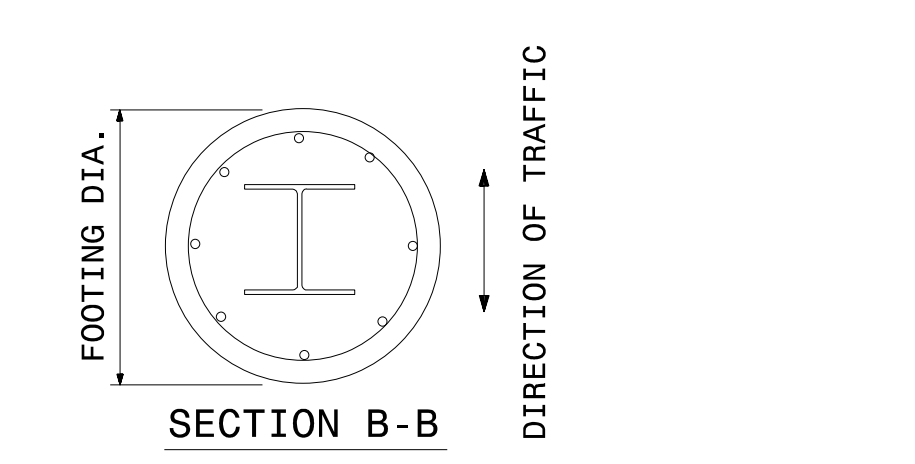
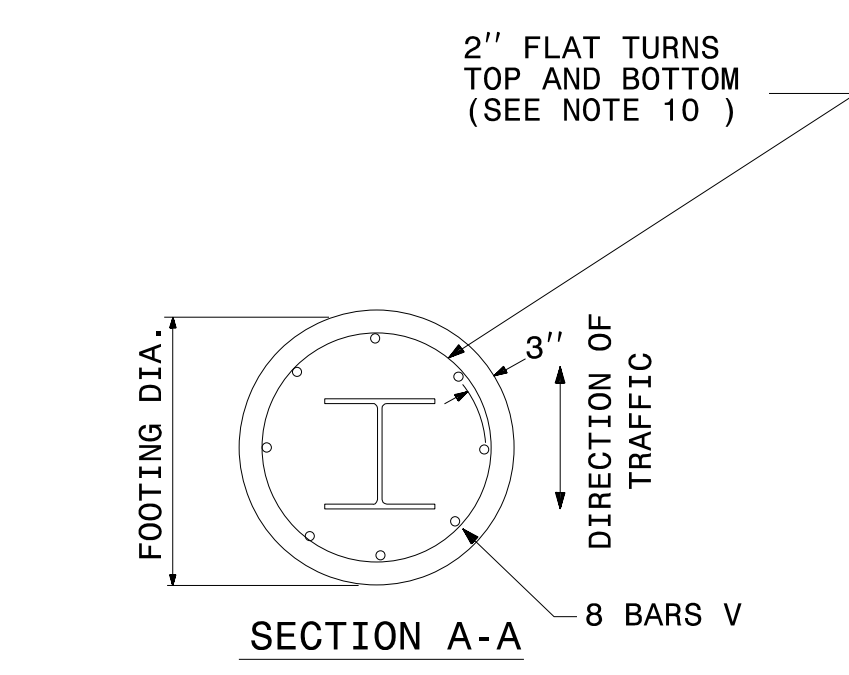

FOUNDATION DATA *		
FOOTING DIAMETER	REINFORCEMENT	SPIRAL BAR
1'-6"	8 # 6 BARS	#3 BAR, 6" PITCH
2'	8 # 7 BARS	#3 BAR, 6" PITCH
2'-6"	8 # 9 BARS	#3 BAR, 6" PITCH
3'	8 # 11 BARS	#3 BAR, 6" PITCH
3'-6"	8 # 12 BARS	#3 BAR, 6" PITCH
4'	8 # 14 BARS	#3 BAR, 6" PITCH

* FOUNDATION DIMENSIONS ARE SHOWN IN PLANS

STATE OF NORTH CAROLINA
 DEPT. OF TRANSPORTATION
 DIVISION OF HIGHWAYS
 RALEIGH, N.C.

ENGLISH DETAIL DRAWING FOR
GROUND MOUNTED SIGN SUPPORTS

SHEET 2 OF 3
903D10

**REVISED SIGNING
 ROADWAY STANDARD DRAWING**

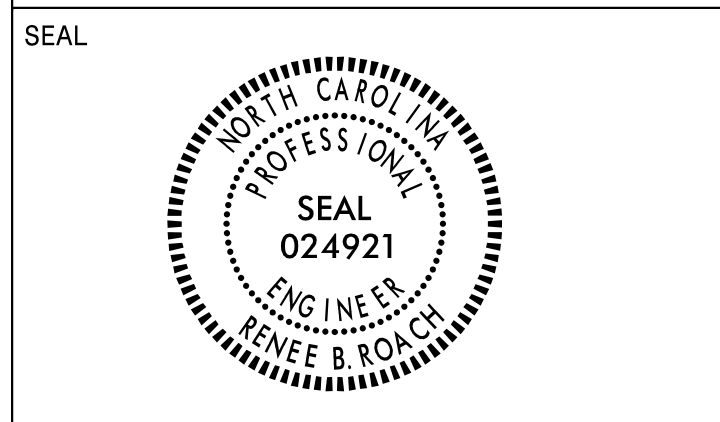

**DOCUMENT NOT CONSIDERED FINAL
 UNLESS ALL SIGNATURES COMPLETED**

STATE OF
 NORTH CAROLINA
 DEPT. OF TRANSPORTATION
 DIVISION OF HIGHWAYS
 RALEIGH, N.C.

1-12

ENGLISH STANDARD DRAWING FOR
GROUND MOUNTED SIGN SUPPORTS

SHEET 1 OF 3

903D10

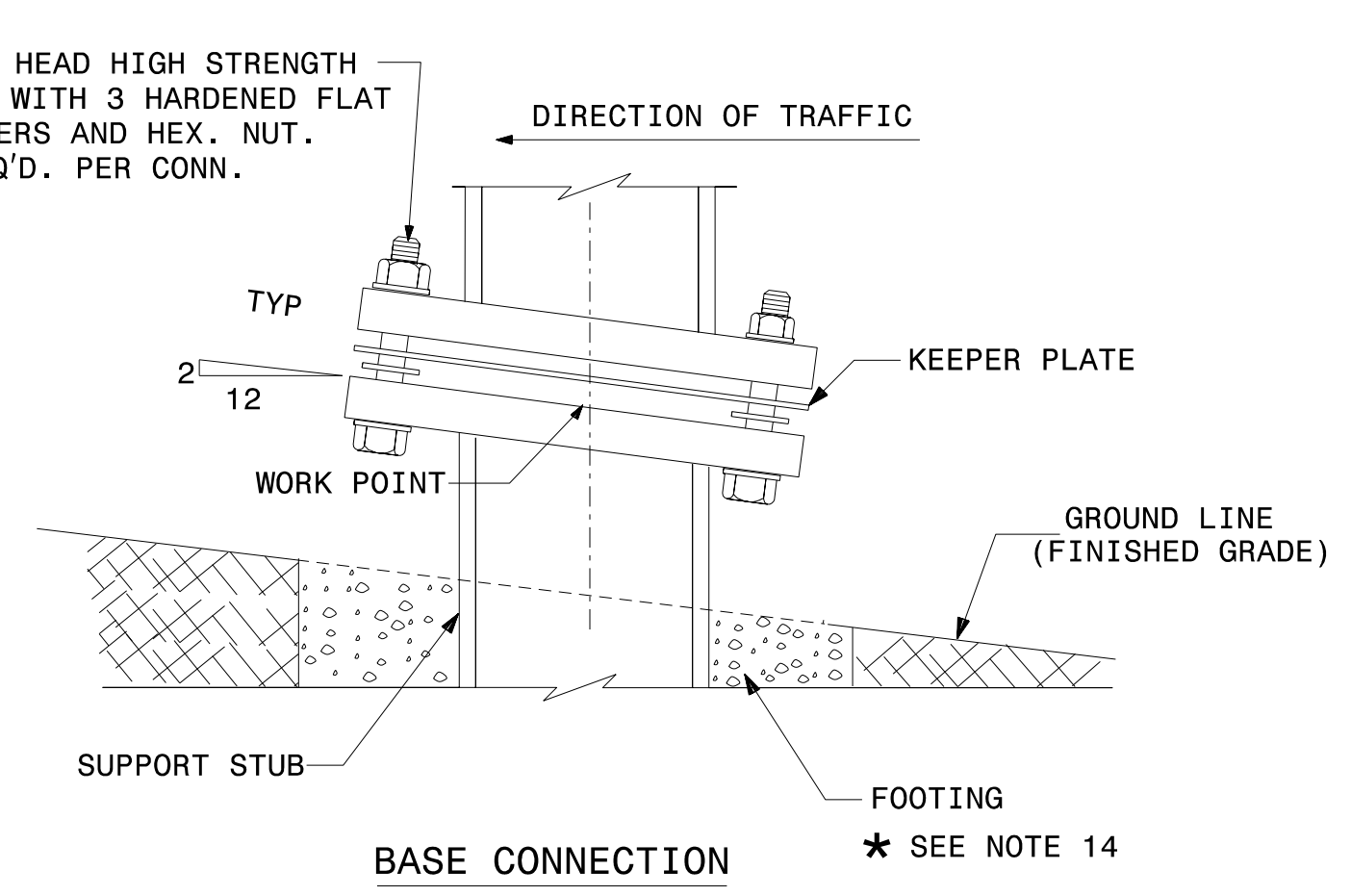
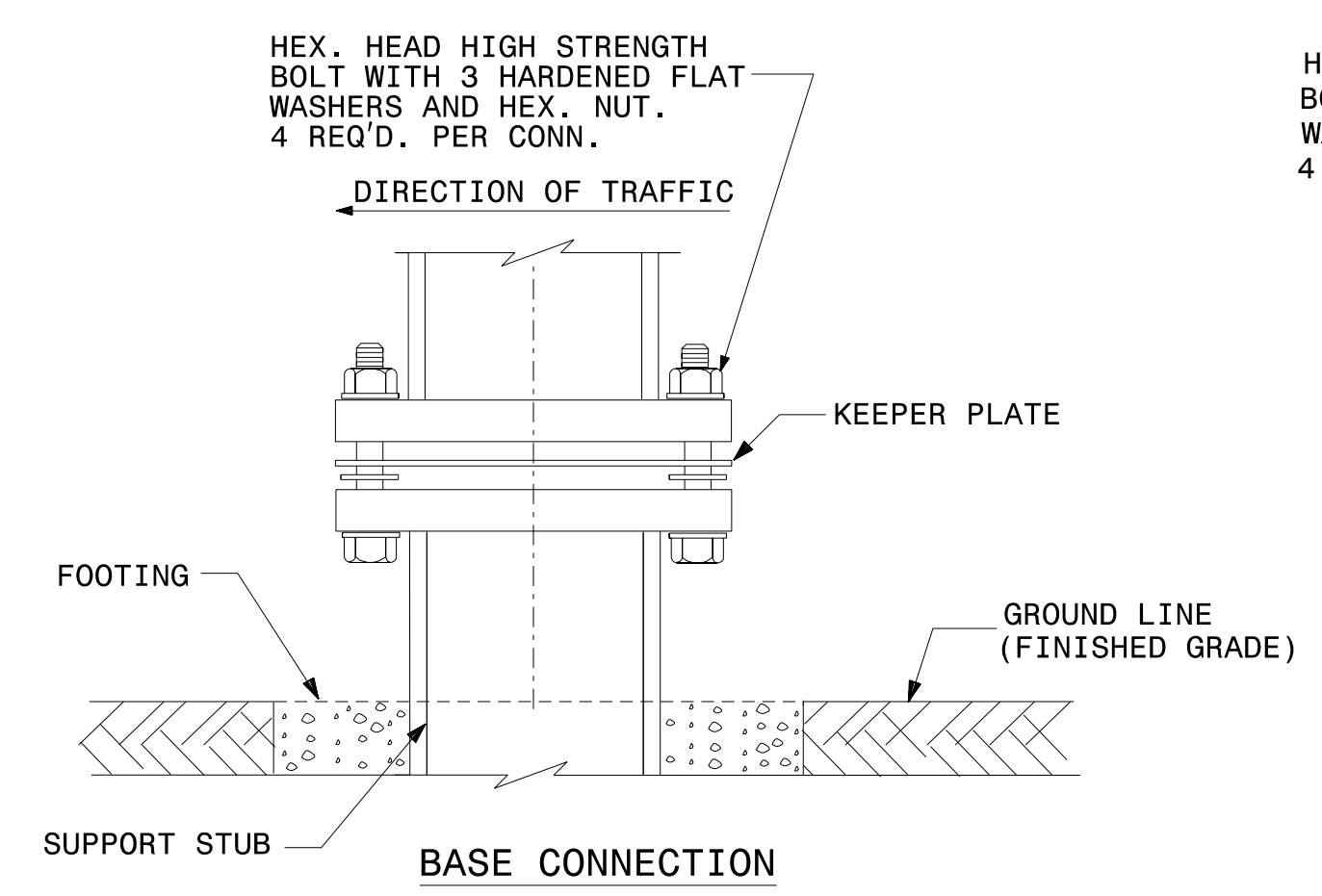
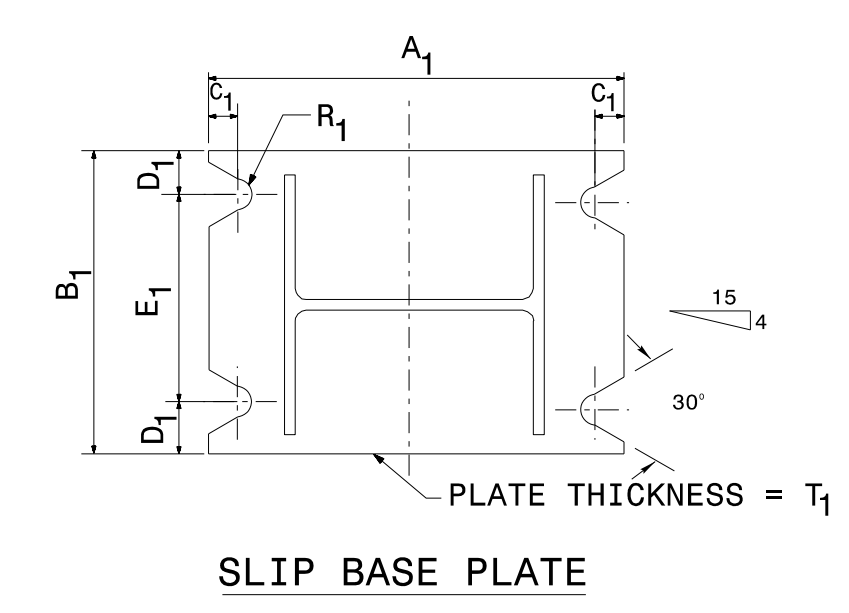
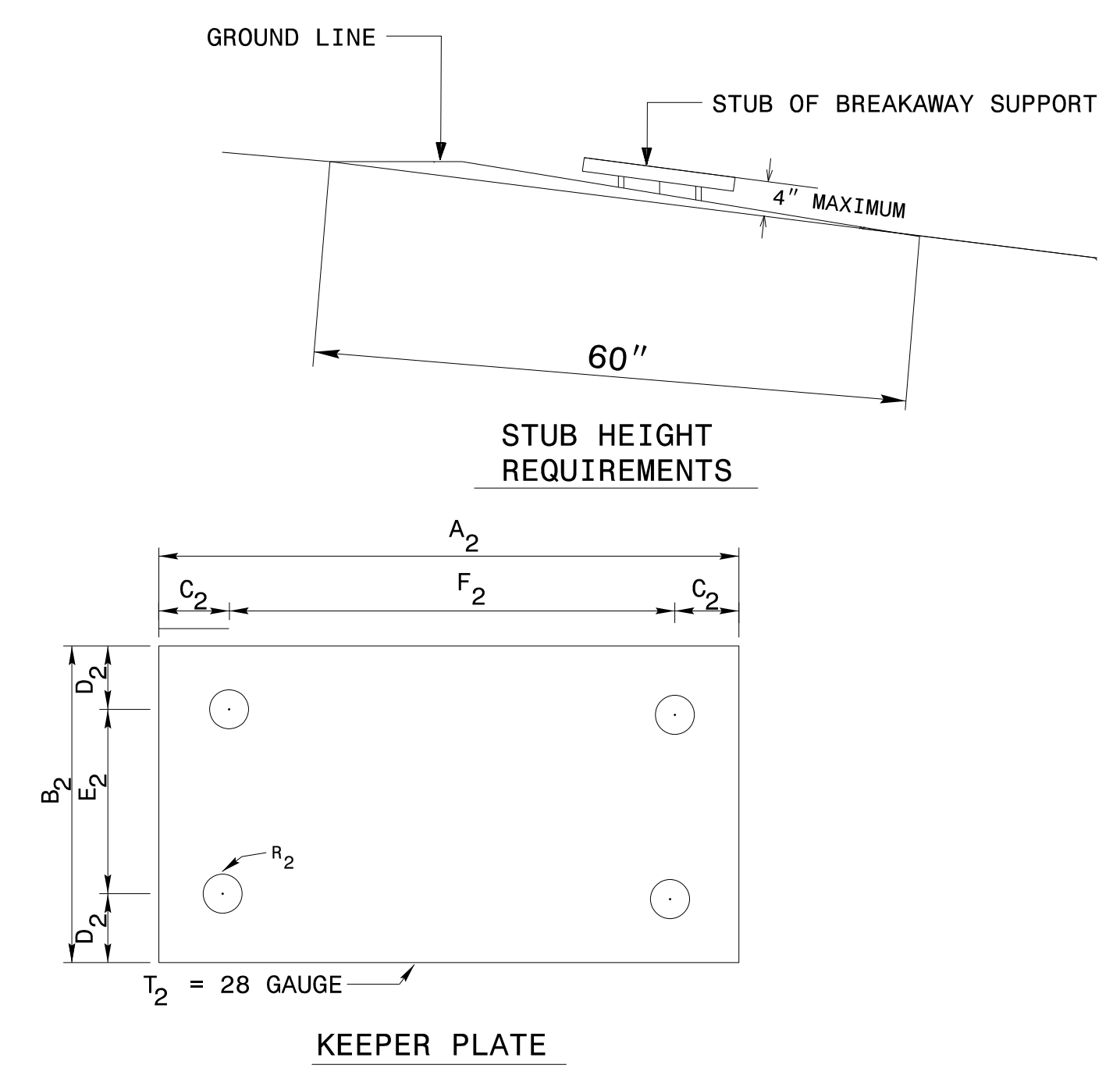
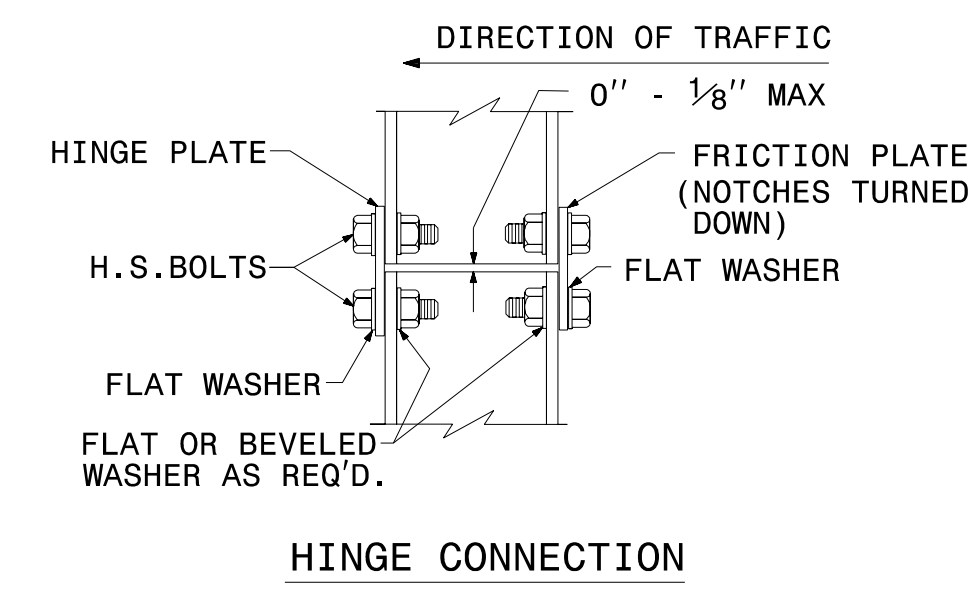
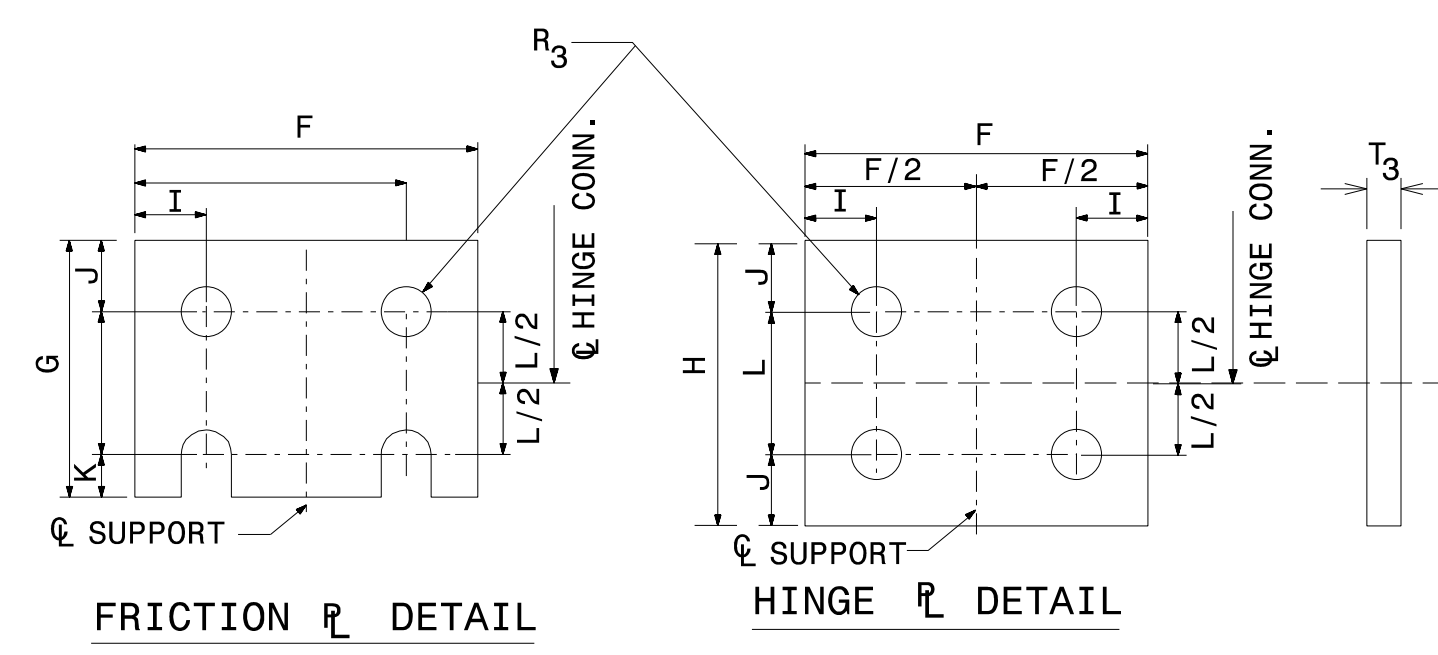
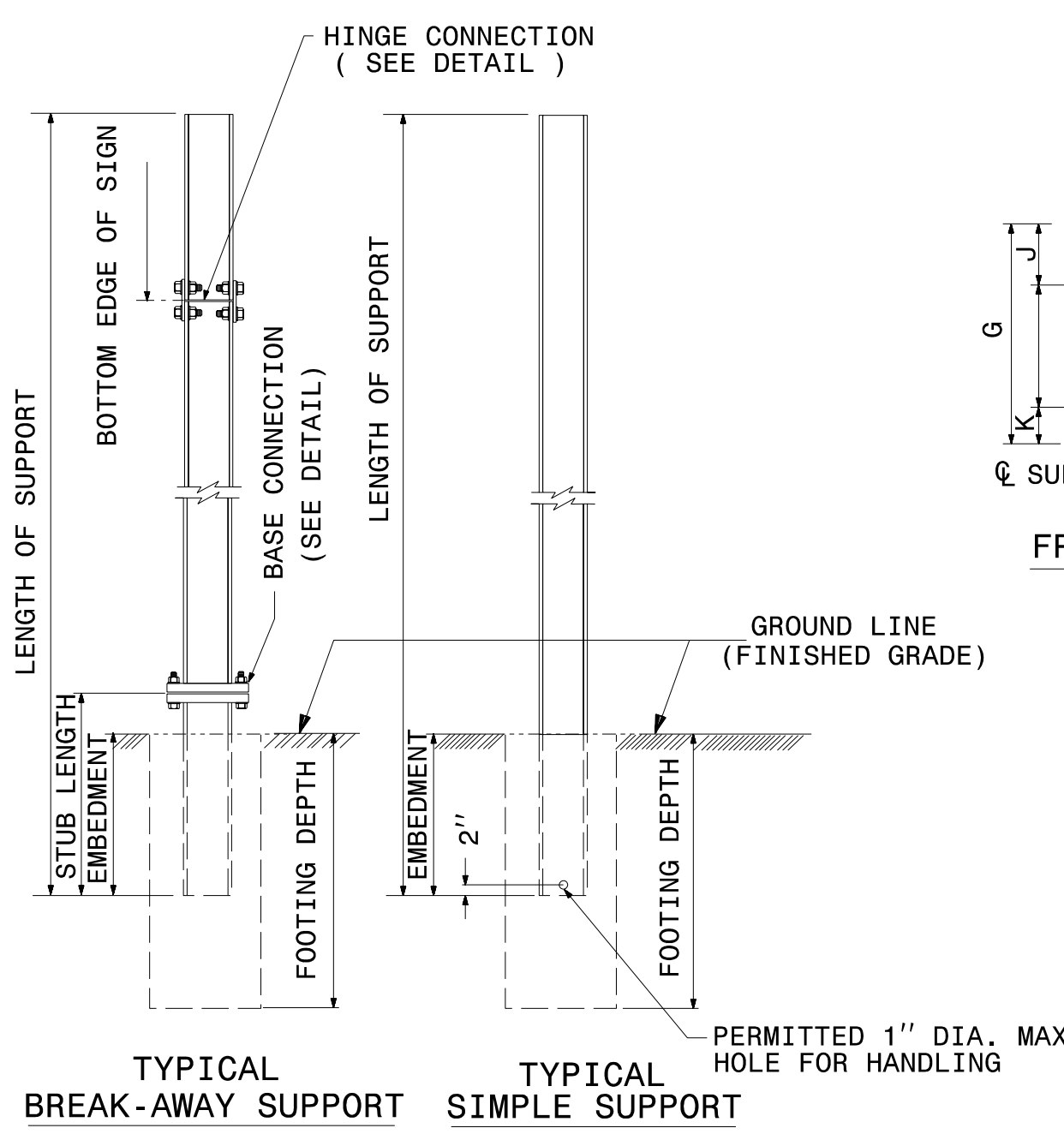

SEE SHEET 2 OF 3 FOR
 BASE CONNECTION DATA
 HINGE CONNECTION DATA
 & FOUNDATION DATA.
 SEE SHEET 3 OF 3 FOR
 GENERAL NOTES.

STATE OF
 NORTH CAROLINA
 DEPT. OF TRANSPORTATION
 DIVISION OF HIGHWAYS
 RALEIGH, N.C.

1-12

ENGLISH STANDARD DRAWING FOR
GROUND MOUNTED SIGN SUPPORTS

SHEET 1 OF 3

903D10

3/27/2017
 P:\TIP\Projects-U\U3308-Traffic\Signing\CADD\Signing Layout Plans\U-3308-SGNSTHT_1_Revision.dgn
 Jseris:obns

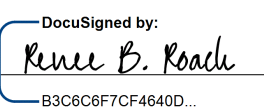
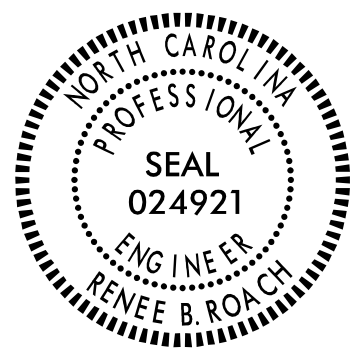
PROJECT REFERENCE NO.	SHEET NO.
U-3308	SIGN-2D
APPROVED:	
DATE:	3/27/2017
SEAL	
	
DOCUMENT NOT CONSIDERED FINAL UNLESS ALL SIGNATURES COMPLETED	

SIGN NUMBER: 101A
TYPE: A
QUANTITY: 1
SIGN WIDTH: 14'-0"
HEIGHT: 2'-6"
TOTAL AREA: 35.0 Sq.Ft.

BORDER TYPE: FLUSH
RECESS: 0"
WIDTH: 2"
RADII: 3"

NO. Z BARS: 2
LENGTH: 160.0

USE NOTES: 1,2

- Legend and border(except those that are colored black) shall be direct applied Grade C sheeting.
- Background shall be Grade C reflective sheeting.

BACKG COLOR: Green
COPY COLOR: White

SYMBOL	X	Y	WID	HT

MAT'L: 0.125" (3.2 mm) ALUMINUM

DESIGN BY: S.Johns
PROJECT ID: U-3308

CHECKED BY: A. ALQUDWAH
LOCATION: NC 147 @ NC 55(Alston Ave)

Mar 14, 2017
DIV: 5

Spacing Factor is 1 unless specified otherwise

LETTER POSITIONS

Letter spacings are to start of next letter

	E	X	I	T	S	1	0	B	-	A		Series/Size Text Length					
	20	8.9	10.7	3.5	8.6	8.1	15	7.9	12.6	7.5	12.2	7.5	5.3	5	15.3	20	E 2000 128.1

FILENAME: SignDesigns NORTH CAROLINA D.O.T. SIGN DETAIL

SIGN NUMBER: 101B
TYPE: A
QUANTITY: 1
SIGN WIDTH: 15'-0"
HEIGHT: 6'-0"
TOTAL AREA: 90.0 Sq.Ft.

BORDER TYPE: FLUSH
RECESS: 0"
WIDTH: 2"
RADII: 9"

NO. Z BARS: 2
LENGTH: 172.0

USE NOTES: 1,2

- Legend and border(except those that are colored black) shall be direct applied Grade C sheeting.
- Background shall be Grade C reflective sheeting.

BACKG COLOR: Green
COPY COLOR: White

SYMBOL	X	Y	WID	HT

MAT'L: 0.125" (3.2 mm) ALUMINUM

DESIGN BY: S.Johns
PROJECT ID: U-3308

CHECKED BY: A. ALQUDWAH
LOCATION: NC 147 @ NC 55(Alston Ave)

Mar 14, 2017
DIV: 5

Spacing Factor is 1 unless specified otherwise

LETTER POSITIONS

Letter spacings are to start of next letter

	B	r	i	g	g	s	A	v	e		Series/Size Text Length		
	20.5	17.4	11.8	8.2	15.5	15.2	10.6	16	18.2	15.5	10.6	20.5	EM 2000 139
	53.5	25	15	12	4.4	9.2	7.5	53.5					E 2000 73.1

FILENAME: SignDesigns NORTH CAROLINA D.O.T. SIGN DETAIL

TYPE "A" SIGNS

3/27/2017 P:\TIP\Projects-U\U3308-Traffic\Signing\CADD\Signing Layout Plans\U-3308-SGN-SHT_1_Revision.dgn jserts@dnr

APPROVED: *Ronald W. King*
09907AB67C4DC...
 DATE: 4/6/2015

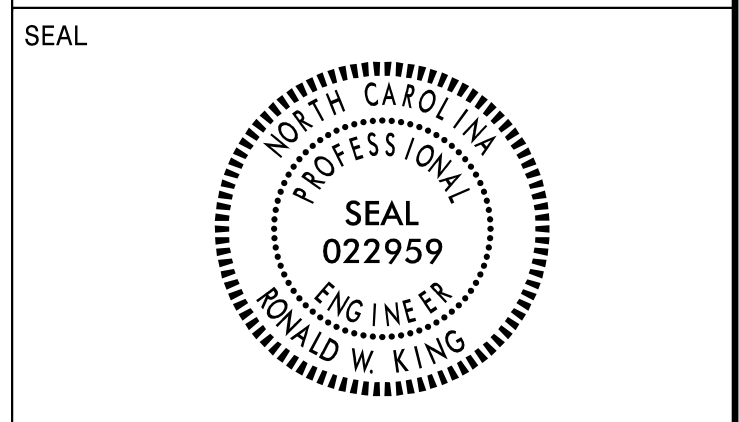

501 511

JCT 1-21 x 15
 147 1-30 x 24

ONE "U" POST PER SIGN

506

WEST EAST 2-24 x 12
 55 55 2-24 x 24
 ← → 2-21 x 15

TWO "U" POSTS PER SIGN

512 523

WEST 1-24 x 12
 55 1-24 x 24

ONE "U" POST PER SIGN

520

WEST 1-24 x 12
 BUSINESS WEST 2-24 x 12
 70 98 2-24 x 24
 EAST WEST 2-24 x 12
 55 55 2-24 x 24
 ← → 2-21 x 15

TWO "U" POSTS PER SIGN

521

WEST 1-24 x 12
 BUSINESS WEST 2-24 x 12
 70 98 2-24 x 24

TWO "U" POSTS PER SIGN

522

EAST 1-24 x 12
 BUSINESS EAST 2-24 x 12
 70 98 2-24 x 24
 WEST EAST 2-24 x 12
 55 55 2-24 x 24
 ← → 2-21 x 15

TWO "U" POSTS PER SIGN

525

EAST WEST 2-24 x 12
 BUSINESS BUSINESS 2-24 x 12
 70 70 2-24 x 24
 EAST WEST 2-24 x 12
 98 98 2-24 x 24
 ← → 2-21 x 15

TWO "U" POSTS PER SIGN

502 513 514 526

EAST 1-24 x 12
 55 1-24 x 24

ONE "U" POST PER SIGN

507

SOUTH EAST 2-24 x 12
 147 55 1-30 x 24
 1-24 x 24
 ← → 2-21 x 15

TWO "U" POSTS PER SIGN

515 524

EAST 1-24 x 12
 BUSINESS 1-24 x 12
 70 1-24 x 24
 98 1-24 x 24

ONE "U" POST PER SIGN

503

NORTH SOUTH 2-24 x 12
 147 147 2-30 x 24
 ↑ → 2-21 x 15

TWO "U" POSTS PER SIGN

508

NORTH 1-24 x 12
 147 H 1-30 x 24
 1-24 x 24
 → → 2-21 x 15

TWO "U" POSTS PER SIGN

516

WEST EAST 2-24 x 12
 BUSINESS BUSINESS 2-24 x 12
 70 70 2-24 x 24
 WEST EAST 2-24 x 12
 98 98 2-24 x 24
 ← → 2-21 x 15

TWO "U" POSTS PER SIGN

504

WEST NORTH 2-24 x 12
 55 147 1-24 x 24
 1-30 x 24
 ↑ → 2-21 x 15

TWO "U" POSTS PER SIGN

509

H 1-24 x 24
 → 1-21 x 15
 SOUTH NORTH 2-24 x 12
 147 147 2-30 x 24
 ↑ → 2-21 x 15

TWO "U" POSTS PER SIGN

517

EAST 1-24 x 12
 BUSINESS EAST 2-24 x 12
 70 98 2-24 x 24

TWO "U" POSTS PER SIGN

505

SOUTH 1-24 x 12
 147 1-30 x 24
 ← 1-21 x 15

ONE "U" POST PER SIGN

510

WEST EAST 2-24 x 12
 55 55 2-24 x 24
 ← → 2-21 x 15

TWO "U" POSTS PER SIGN

518 519

JCT 1-21 x 15
 55 1-24 x 24

ONE "U" POST PER SIGN

SIGN NUMBER: 301,302 BACKG COLOR: Brown
 TYPE: D COPY COLOR: White
 QUANTITY: 2
 SIGN WIDTH: 4'-6" HEIGHT: 2'-6"
 TOTAL AREA: 11.3 Sq.Ft.
 BORDER TYPE: FLUSH RECESS: 0" WIDTH: 1" RADII: 3"
 NO. Z BARS: LENGTH:
 MAT'L: 0.125" (3.2 mm) ALUMINUM

DESIGN BY: S.Johns CHECKED BY: R.Roach
 PROJECT ID: U-3308 DIV: 5 DATE: Mar 11, 2015

SYMBOL	X	Y	WID	HT
Historic Sites	3.3	6.8	18	10.7

USE NOTES: 1,2
 1. Legend and border(except those that are colored black) shall be direct applied Grade C sheeting.
 2. Background shall be Grade C reflective sheeting.

Spacing Factor is 1 unless specified otherwise

LETTER POSITIONS

Letter spacings are to start of next letter

	G	o	l	d	e	n	B	e	l	t				Series/Size
19.7	3.5	3.3	1.4	3.3	3.2	2.6	4	3.4	3.2	1.2	1.8	3.3		C 2000
														31
26.3	3.8	1.3	2.3	2.2	3.3	2.2	1.4	2.5	8.6					C 2000
														19.1
27.1	3.7	1.3	2.3	2.3	2.2	1.4	2.7	1.8	9.1					C 2000
														17.8

FILENAME: GoldenBeltSign.dgn NORTH CAROLINA D.O.T. SIGN DETAIL

TYPES "D" & "F" SIGNS

4/6/2015 P:\Projects-U\U3308-Traffic\Signing\CADD\Signing Layout Plans\U-3308-SGN-SHT-1.dgn

NAD 83/95

3-20-17 - REMOVE GROUND MOUNTED SIGN ON NC 147 EB LANE.
ADDED SIGNS NO. 101A & 101B. S.JOHN'S

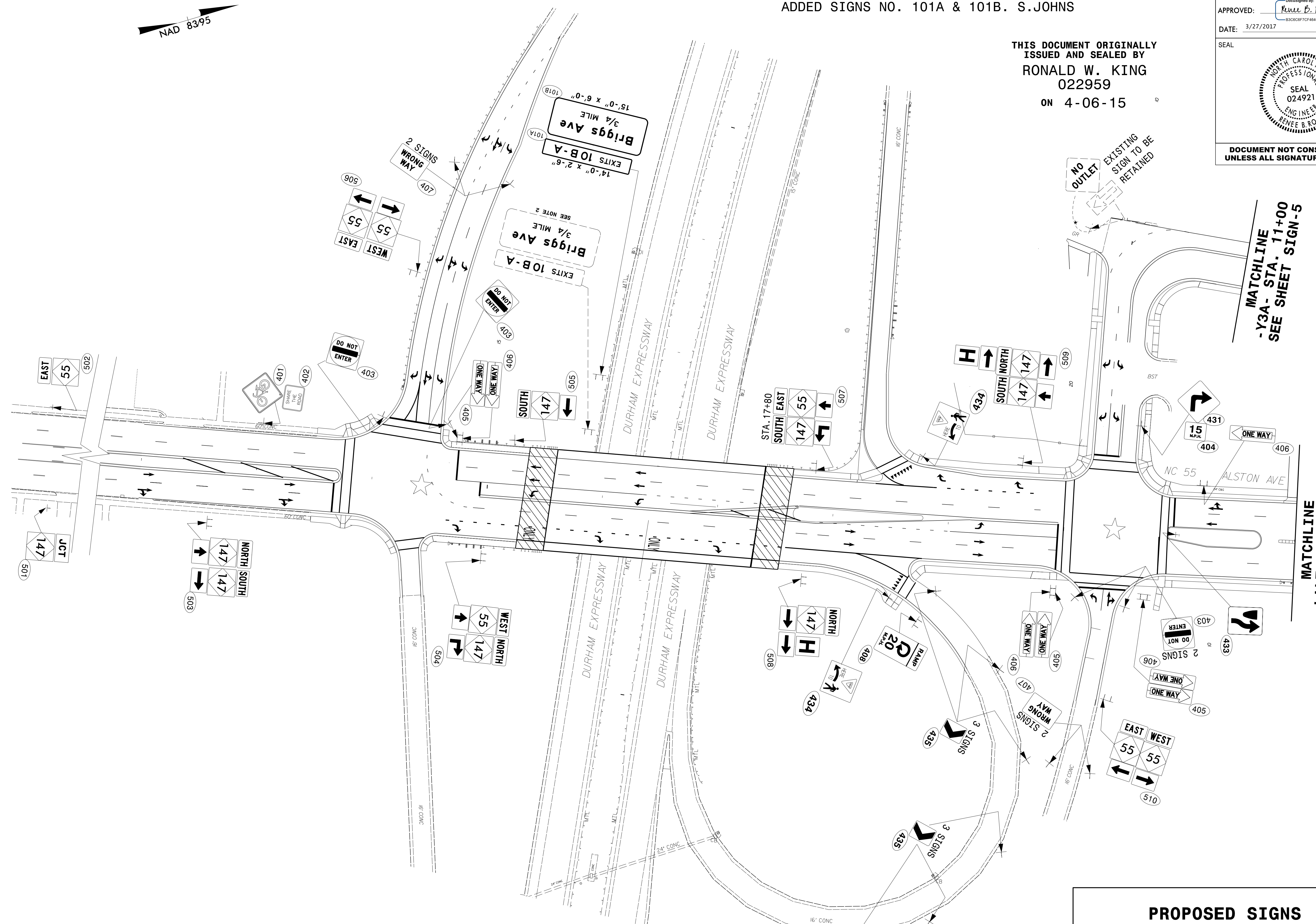

THIS DOCUMENT ORIGINALLY
ISSUED AND SEALED BY
RONALD W. KING
022959
ON 4-06-15

PROJECT REFERENCE NO. U-3308	SHEET NO. SIGN-4
APPROVED: <i>Renee B. Roach</i>	DocuSigned by: Renee B. Roach B3C6C6F7CF4640D...
DATE: 3/27/2017	
SEAL	
	
DOCUMENT NOT CONSIDERED FINAL UNLESS ALL SIGNATURES COMPLETED	



**PROPOSED SIGNS
STA. 12+00 TO STA. 22+00**

3/27/2017
P:\TIP\Projects-U\U3308-Traffic\Signing\CADD\Signing Layout Plans\U-3308-SGN5HT_4Revision.dgn
User: rjohns

PROJECT REFERENCE NO. U-3308	SHEET NO. SIGN-5
APPROVED:  0696074867740DC...	
DATE: 4/6/2015	
SEAL	
	

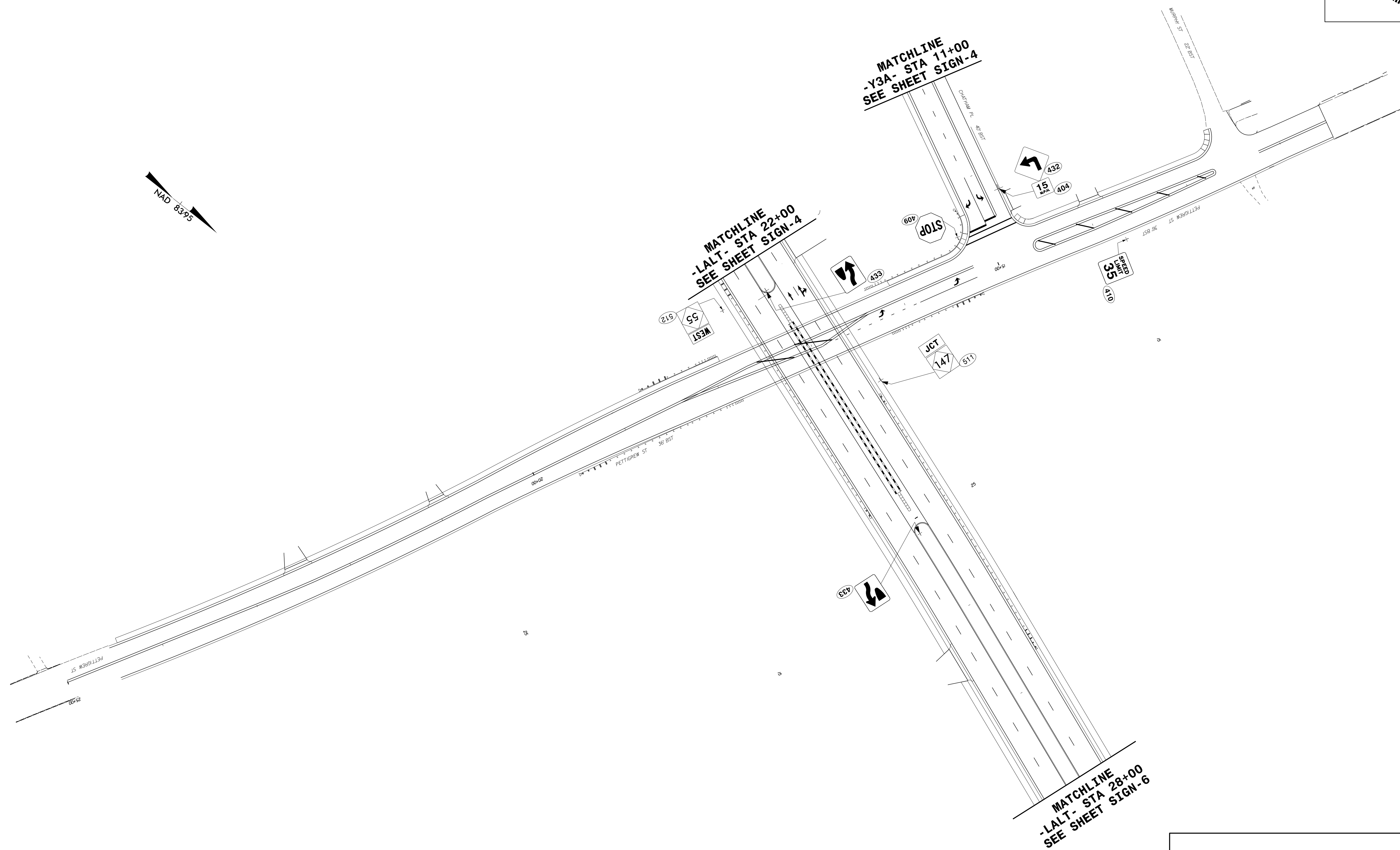
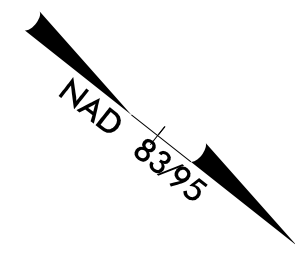

**PROPOSED SIGNS
STA. 22+00 TO 28+00**

4/6/2015
 P:\Projects-U\U3308-Traffic\Signing\CADD\Signing Layout Plans\U-3308-SGN5HT_5.dgn
 Jseris:rbns

PROJECT REFERENCE NO. U-3308	SHEET NO. SIGN-6
APPROVED: <i>Ronald W. King</i> 0698074867740C...	
DATE: 4/6/2015	
SEAL	



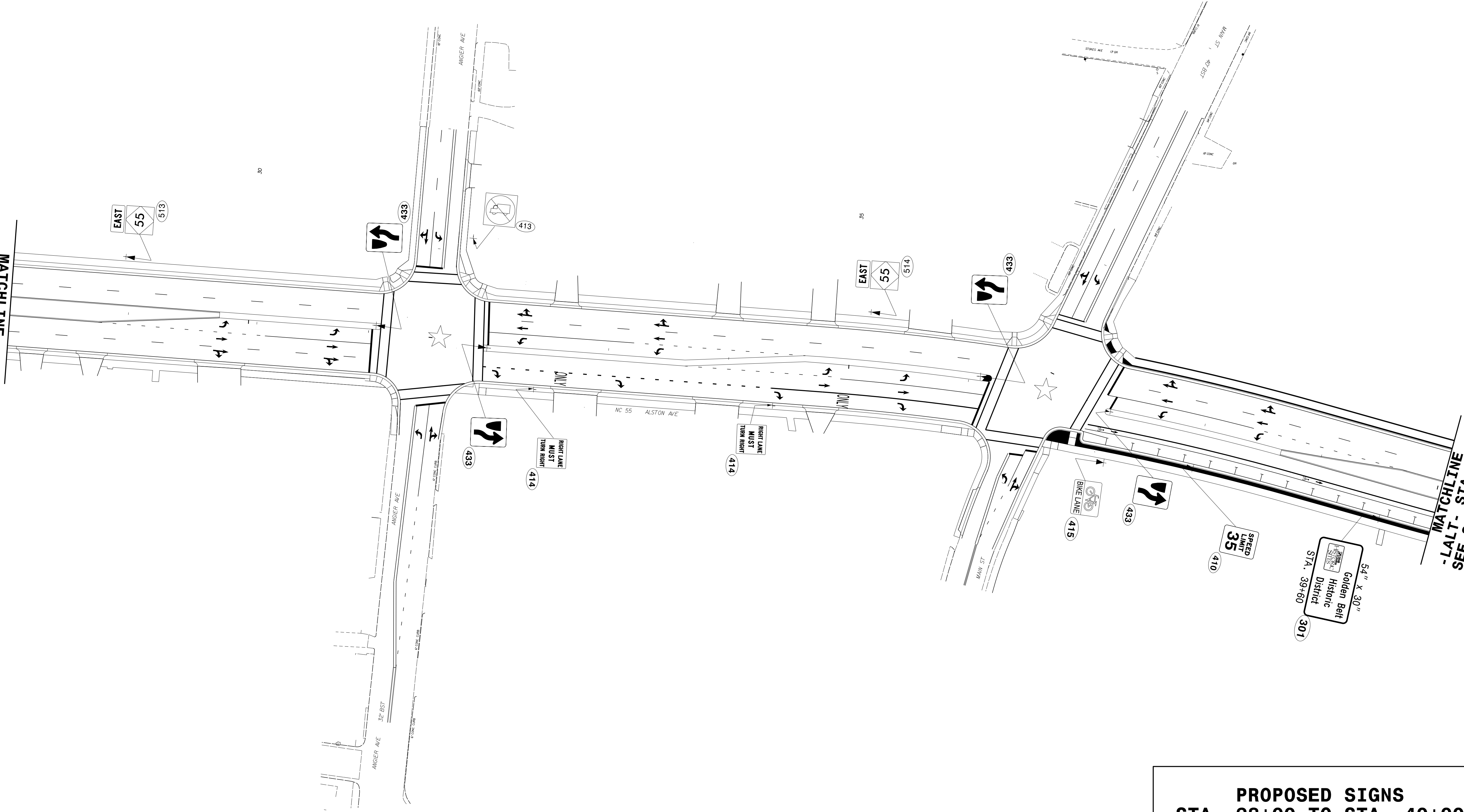

MATCHLINE
-LALT- STA 28+00
SEE SHEET SIGN-5

MATCHLINE
-LALT- STA 40+00
SEE SHEET SIGN-7

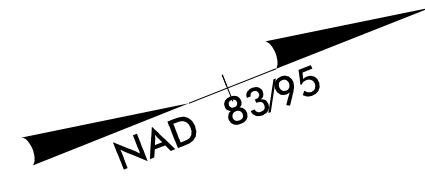

**PROPOSED SIGNS
STA. 28+00 TO STA. 40+00**

4/6/2015
P:\TIP\Projects-U\U3308\Traffic\Signing\CADD\Signing Layout Plans\U-3308-SGN5HT_6.dgn
Jseris:tdns



MATCHLINE
- LALT- STA 40+00
SEE SHEET SIGN-6

MATCHLINE
- LALT- STA 47+30
SEE SHEET SIGN-8

PROPOSED SIGNS
STA. 40+00 TO STA. 47+30



4/6/2015
 P:\Projects-U\U3308-Traffic\Signing\CADD\Signing Layout Plans\U-3308-SGNSHT_8.dgn
 Jserstobns

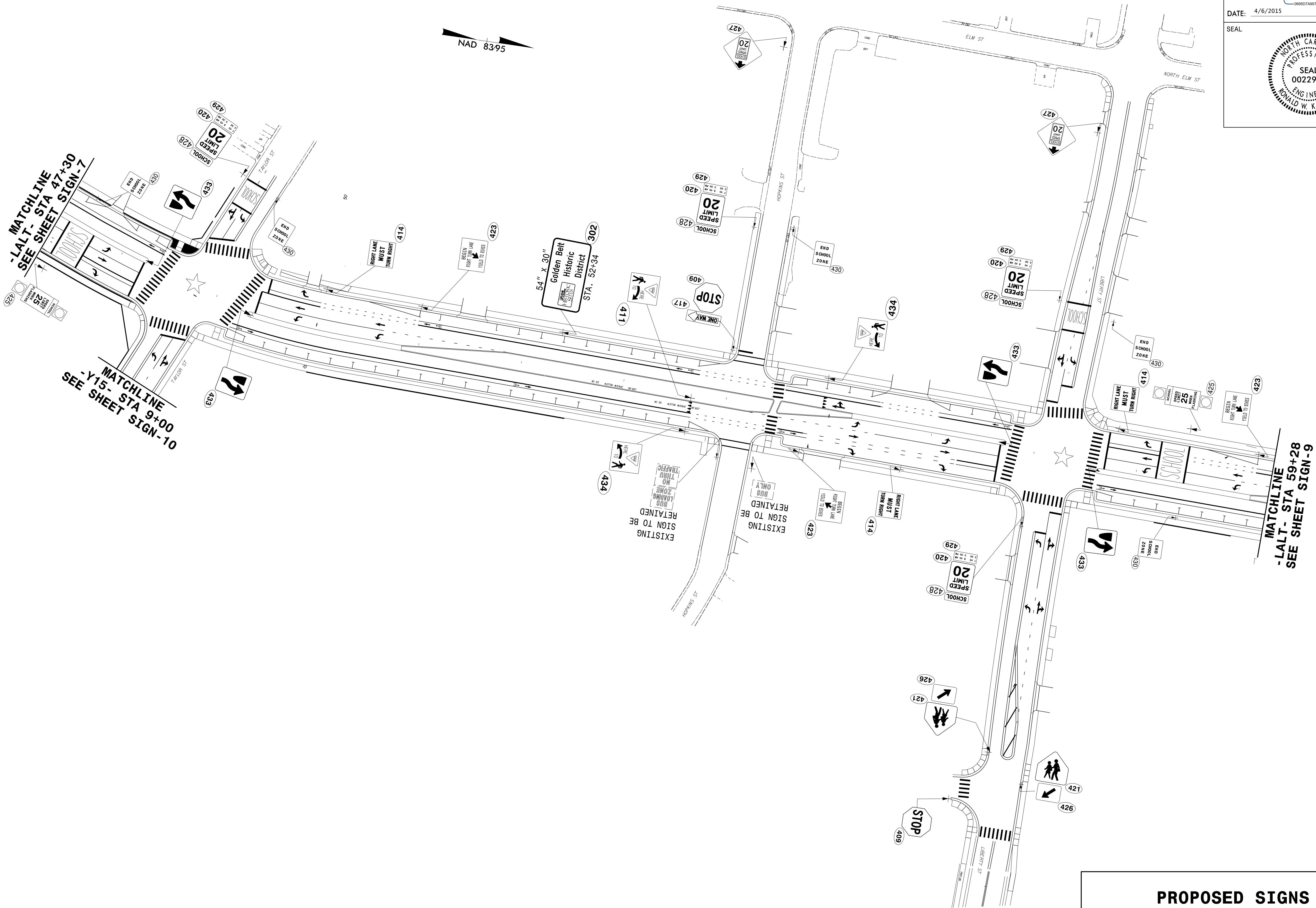

MATCHLINE
-LALT- STA 47+30
SEE SHEET SIGN-7

MATCHLINE
-Y15- STA 9+00
SEE SHEET SIGN-10

54' X 30'
Golden Belt
Historic
District
STA. 52+34

MATCHLINE
-LALT- STA 59+28
SEE SHEET SIGN-9

**PROPOSED SIGNS
STA. 47+50 TO STA. 59+28**

MATCHLINE
-LALT- STA 59+28
SEE SHEET SIGN-8

NAD 83/95

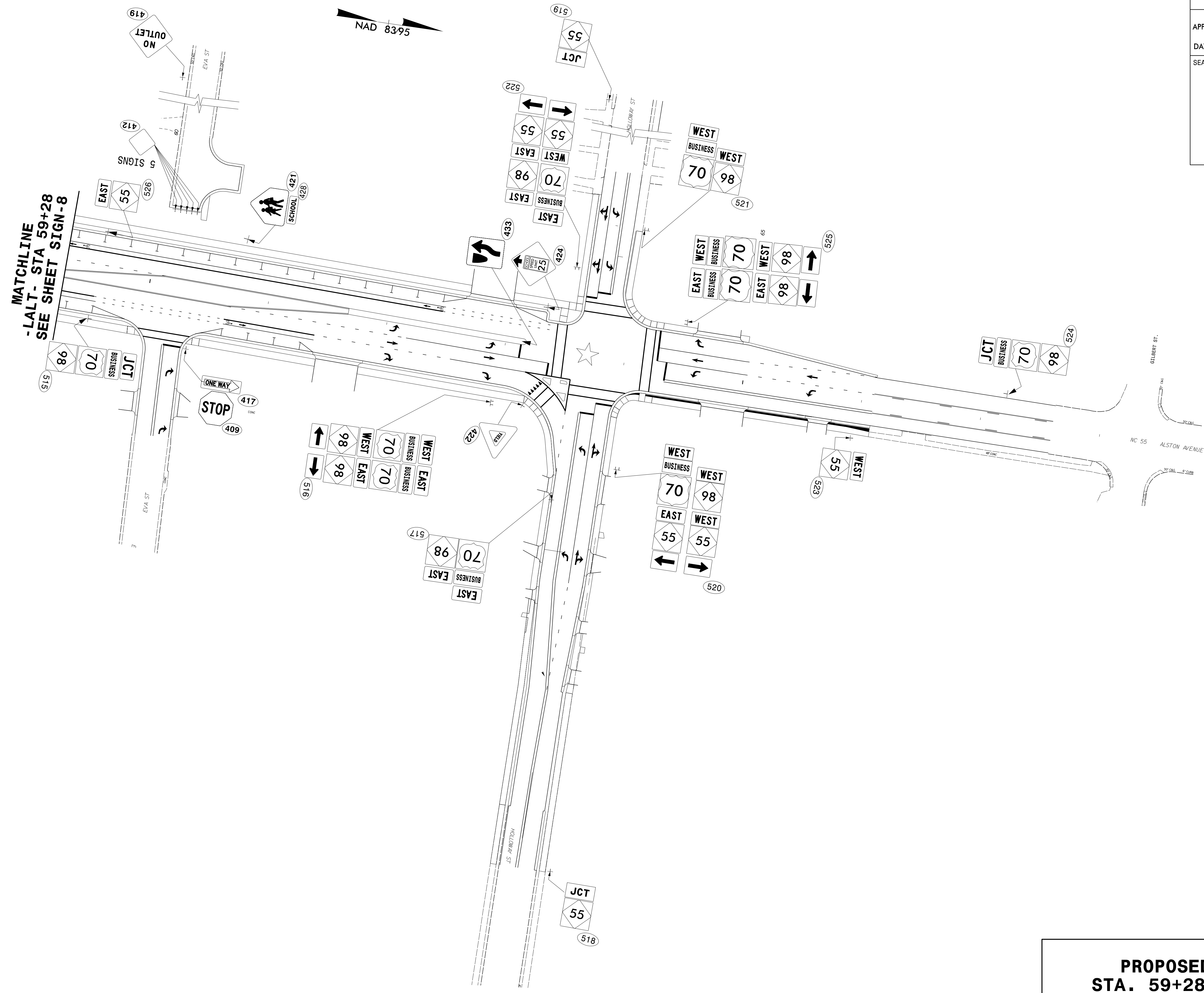

4/6/2015
 P:\Projects\UNU3308\Traffic\Signing\CADD\Signing Layout Plans\U-3308-SGNSHT-9.dgn
 Jserstobns

**PROPOSED SIGNS
STA. 59+28 TO 67+60**

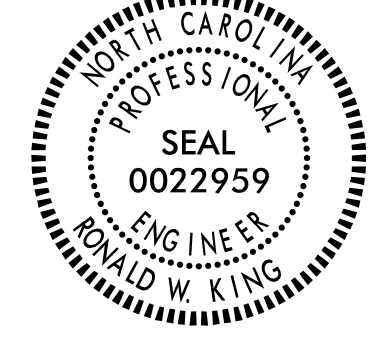
PROJECT REFERENCE NO. U-3308	SHEET NO. SIGN-10
APPROVED:  09907486774DC...	
DATE: 4/6/2015	
SEAL	
	

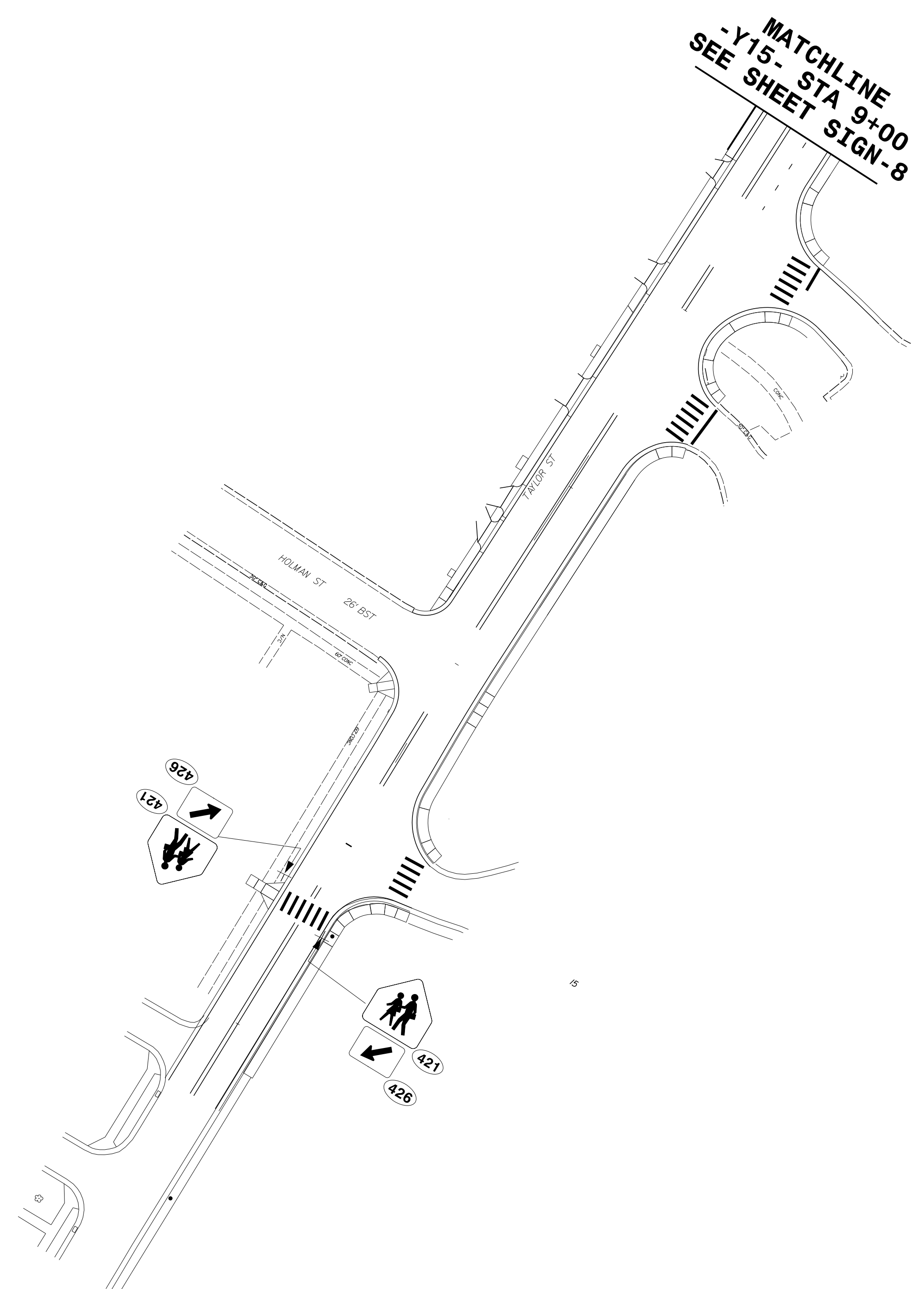
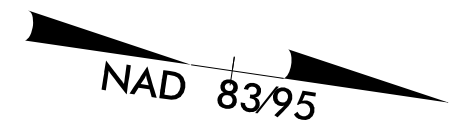

**PROPOSED SIGNS
STA. 9+00 TO 15+40**

4/6/2015
 P:\Projects\UNU3308\Traffic\Signing\CADD\Signing Layout Plans\U-3308-SGN-SHT_10.dgn
 Insertions