

SECTION A-A

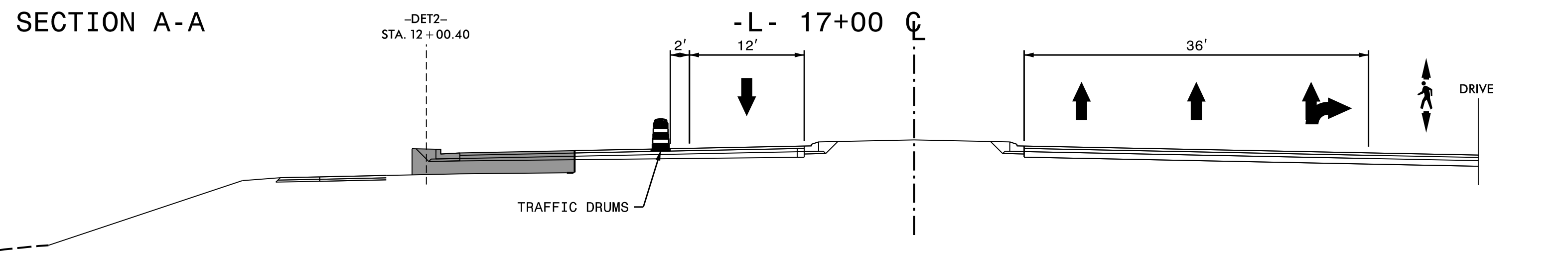

- ① TEMPORARY SHORING TO REMAIN FROM PHASE 1 (SEE TMP-4)
SEE SHEET TMP-2A FOR TEMPORARY SHORING INFORMATION.
- A SIGNS TO REMAIN FROM PHASE 1 (SEE TMP-4)
- B SIGNS AND DEVICES TO REMAIN FROM PHASE 2 (SEE TMP-6)

PROJ. REFERENCE NO. B-5123	SHEET NO. TMP-18
HDR Engineering, Inc. of the Carolinas 555 Fayetteville St, Suite 900 Raleigh, N.C. 27601 N.C.B.E.L.S. License Number: F-0116	

PLOT DRIVER: NCDOT_pdf_color_eng_50.pit
 USER: CHARNDEN
 DATE: 1/29/2016
 TIME: 9:45:25 AM
 FILE: p:\WPAPP\TPA01\SouthEast\Tampa\Documents\000166\CON0079759\CON0104476\000000000272555\6.0.CAD.BIM\6.2.Work_In_Progress\TrafficControl\TCP\B-5123_TC_TMP-18-Phase5-1.dgn

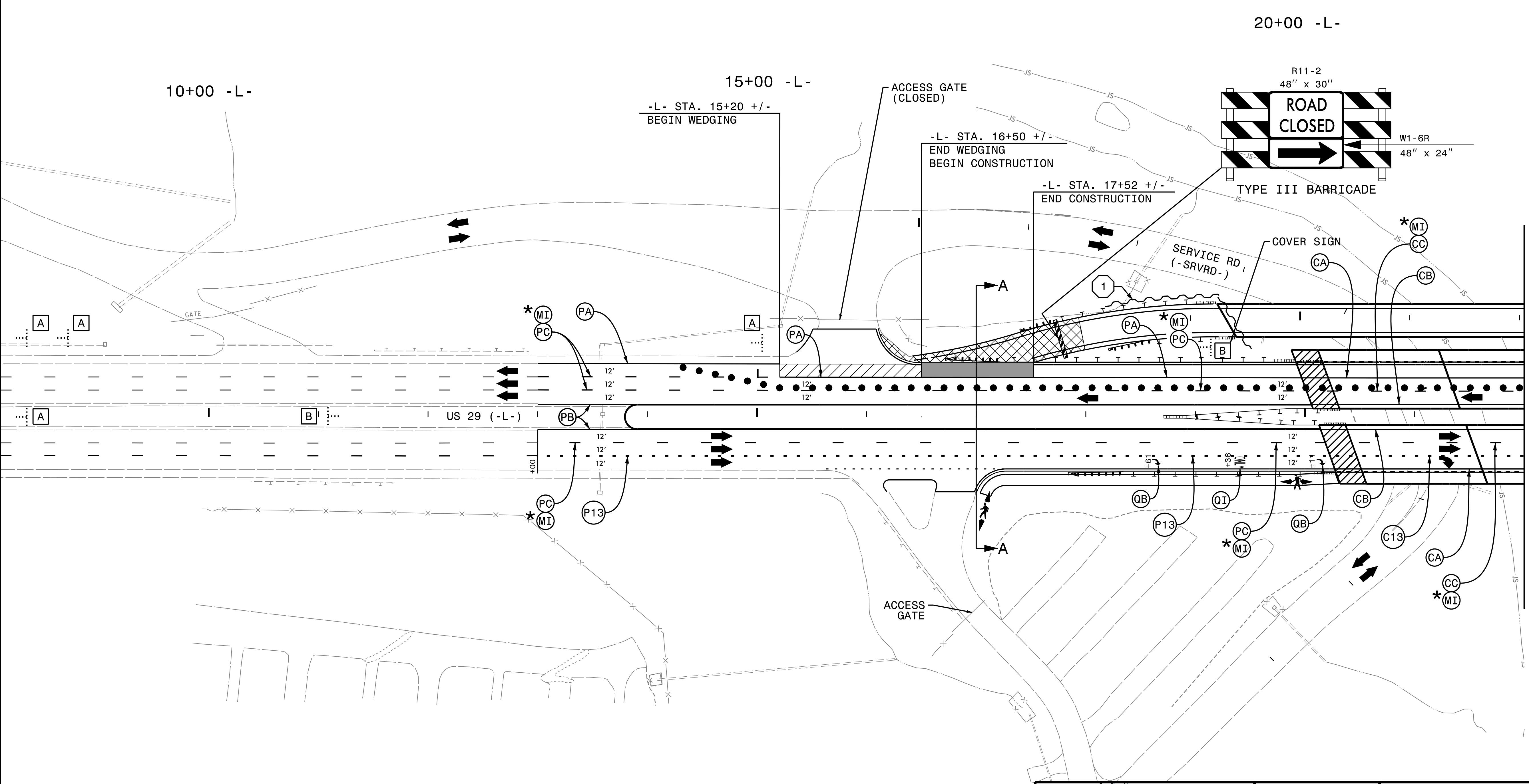

MATCHLINE -L- STA. 22+00, SEE TMP-19

* PLACE CRYSTAL/RED TEMPORARY RAISED MARKERS (MI) @ 40' SPACING ALONG THE LANE LINE BETWEEN 10' SKIPS

APPROVED: *Ben Schoenbauer*
 DATE: 1/29/2016

DOCUMENT NOT CONSIDERED FINAL UNLESS ALL SIGNATURES COMPLETED

DIVISION OF HIGHWAYS
 NORTH CAROLINA
 DEPARTMENT OF TRANSPORTATION
 WORK ZONE TRAFFIC CONTROL

PHASE 5
STEP 1