

**This electronic collection of documents is provided
for the convenience of the user
and is Not a Certified Document –**

**The documents contained herein were originally issued
and sealed by the individuals whose names and license
numbers appear on each page, on the dates appearing
with their signature on that page.**

**This file or an individual page
shall not be considered a certified document.**

TIP NO. B-5121/B-5317	SHEET NO. PMP-1
APPROVED: <i>Ronald W. King</i> DATE: 2/1/2016	
SEAL 	
DOCUMENT NOT CONSIDERED FINAL UNLESS ALL SIGNATURES COMPLETED	

**STATE OF NORTH CAROLINA
DEPARTMENT OF TRANSPORTATION**

**PAVEMENT MARKING PLAN
WAKE COUNTY**

**LOCATION: BRIDGE NO. 227 ON US 70/US 401/NC 50 (CAPITAL BLVD) OVER PEACE ST AND
BRIDGE NO. 213 ON US 70/NC 50 (WADE AVE) OVER US 401 (CAPITAL BLVD)**

CONTRACT: C203751 T.I.P.: B-5121/B-5317

ROADWAY STANDARD DRAWING

THE FOLLOWING ROADWAY STANDARDS AS APPEAR IN "ROADWAY STANDARD DRAWINGS" - PROJECT SERVICES UNIT - N.C. DEPARTMENT OF TRANSPORTATION - RALEIGH, N.C., DATED JANUARY 2012 ARE APPLICABLE TO THIS PROJECT AND BY REFERENCE HEREBY ARE CONSIDERED A PART OF THESE PLANS:

STD. NO.	TITLE
1205.01	PAVEMENT MARKINGS - LINE TYPES AND OFFSETS
1205.02	PAVEMENT MARKINGS - TWO-LANE AND MULTILANE ROADWAYS
1205.03	PAVEMENT MARKINGS - EXIT AND ENTRANCE RAMP
1205.04	PAVEMENT MARKINGS - INTERSECTIONS
1205.05	PAVEMENT MARKINGS - TURN LANES
1205.06	PAVEMENT MARKINGS - LANE DROPS
1205.08	PAVEMENT MARKINGS - SYMBOLS AND WORD MESSAGES
1205.09	PAVEMENT MARKINGS - PAINTED ISLANDS
1205.12	PAVEMENT MARKINGS - BRIDGES
1250.01	RAISED PAVEMENT MARKERS - INSTALLATION SPACING
1251.01	RAISED PAVEMENT MARKERS - PERMANENT AND TEMPORARY
1253.01	RAISED PAVEMENT MARKERS - SNOWPLOWABLE
1261.01	GUARDRAIL AND BARRIER DELINEATORS - INSTALLATION SPACING
1261.02	GUARDRAIL AND BARRIER DELINEATORS - TYPES AND MOUNTING
1262.01	GUARDRAIL END DELINEATION

INDEX

SHEET NO.	DESCRIPTION
PMP-1	PAVEMENT MARKING PLAN TITLE & SCHEDULE
PMP-2	CROSSWALK PAVEMENT MARKING GUIDANCE DETAIL
PMP-2A	REVISED PAVEMENT MARKING ROADWAY STANDARD DRAWING
PMP-3-7	PAVEMENT MARKING DETAIL

PLAN PREPARED BY: N.C.D.O.T. SIGNING AND DELINEATION UNIT

RENEE B. ROACH, P.E. SIGNING & DELINEATION REGIONAL ENGINEER
STACEY W. JOHNS SIGNING & DELINEATION DESIGN ENGINEER

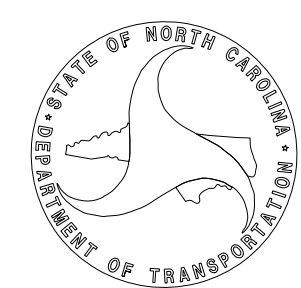

PAVEMENT MARKING SCHEDULE

	THERMO(24", 120 MILS)
T2	WHITE STOPBAR
T3	WHITE CROSSWALK LINE
	THERMO(4", 120 MILS)
T8	2 FT. - 6 FT./SP WHITE MINISKIP
TC	10 FT. WHITE SKIP
TD	3 FT. - 9 FT./SP WHITE MINISKIP
TE	WHITE SOLID LANE LINE
TF	10 FT. YELLOW SKIP
TH	YELLOW SINGLE CENTER
TI	YELLOW DOUBLE CENTER
	THERMO(4", 90 MILS)
TA	WHITE EDGELINE
TB	YELLOW EDGELINE
	THERMO(8", 120 MILS)
T13	3 FT. - 9 FT./SP WHITE MINISKIP
TQ	WHITE CROSSWALK LINE
TR	WHITE SOLID LANE LINE
	THERMO(8", 90 MILS)
TN	WHITE GORELINE
	THERMOPAVEMENT MARKING CHARACTER (120 MILS)
UI	ALPHANUMERIC CHAR.
	THERMOPAVEMENT MARKING SYMBOLS (90 MILS)
UA	LEFT TURN ARROW
UB	RIGHT TURN ARROW
UC	STRAIGHT ARROW
UD	COMBO. LEFT/STRAIGHT ARROW
UE	COMBO. RIGHT/STRAIGHT ARROW
UJ	BICYCLE SYMBOL
UK	BICYCLE STRAIGHT ARROW
UN	24" YIELD LINE TRIANGLE
	COLD APPLIED PLASTIC(4")
CA	WHITE EDGELINE
CB	YELLOW EDGELINE
CC	10 FT. WHITE SKIP
CD	3 FT. - 9 FT./SP WHITE MINISKIP
	PERMANENT RAISED PAVEMENT MARKERS
MA	YELLOW & YELLOW
MB	CRYSTAL & RED
	SNOWPLOWABLE PAVEMENT MARKERS
ME	YELLOW & YELLOW
MF	CRYSTAL & RED

GENERAL NOTES

- THE FOLLOWING GENERAL NOTES APPLY AT ALL TIMES FOR THE DURATION OF THE CONSTRUCTION PROJECT, EXCEPT WHEN OTHERWISE NOTED IN THE PLAN, OR DIRECTED BY THE ENGINEER.
- INSTALL PAVEMENT MARKINGS AND PAVEMENT MARKERS ON THE FINAL SURFACE AS FOLLOWS:

ROAD NAME	MARKING	MARKER
ALL	THERMOPLASTIC	SNOWPLOWABLE
CONCRETE BRIDGE DECK	COLD APPLIED PLASTIC (TYPE II OR III)	RAISED
 - TIE PROPOSED PAVEMENT MARKING LINES TO EXISTING PAVEMENT MARKING LINES.
 - REMOVE/REPLACE ANY CONFLICTING/DAMAGED PAVEMENT MARKINGS AND MARKERS.
 - PASSING ZONES WILL BE DETERMINED IN THE FIELD AND MUST BE APPROVED BY THE ENGINEER.
 - STOP BAR LOCATION AT NON-SIGNALIZED INTERSECTIONS MAY BE ADJUSTED AS DIRECTED BY THE ENGINEER.
 - REMOVE ALL RESIDUE AND SURFACE LAITANCE BY ACCEPTABLE METHODS ON CONCRETE BRIDGE DECKS PRIOR TO PLACING COLD APPLIED PLASTIC PAVEMENT MARKING MATERIAL.
 - UNLESS OTHERWISE SPECIFIED, HEATED-IN-PLACE THERMOPLASTIC MAY BE USED IN LIEU OF EXTRUDED THERMOPLASTIC FOR STOP BARS, SYMBOLS, CHARACTERS AND DIAGONALS. IF HEATED-IN-PLACE IS USED, IT SHALL BE PAID FOR USING THE EXTRUDED THERMOPLASTIC PAY ITEM.
 - UNLESS OTHERWISE SPECIFIED, HEATED-IN-PLACE THERMOPLASTIC MAY BE USED IN LIEU OF COLD APPLIED PLASTIC FOR STOP BARS, SYMBOLS, CHARACTERS AND DIAGONALS ON ASPHALT OR CONCRETE ROADWAYS. IF HEATED-IN-PLACE IS USED, IT SHALL BE PAID FOR USING THE COLD APPLIED PAY ITEM.
 - ALL BIKE LANE SYMBOLS SHALL BE HEATED-IN-PLACE THERMOPLASTIC. SYMBOLS SHALL BE PAID FOR USING THE HEAT-IN-PLACE PAY ITEM.
 - TYPE III COLD APPLIED PLASTIC MAY BE USED IN LIEU OF TYPE II COLD APPLIED PLASTIC. IF TYPE III COLD APPLIED PLASTIC IS USED, IT SHALL BE PAID FOR USING THE TYPE II COLD APPLIED PLASTIC PAY ITEM.
 - SEE ROADWAY PLANS FOR ALTERNATE CURB RAMP DESIGNS WHEN INDICATED ON PAVEMENT MARKING DETAIL SHEETS.



REVISIONS
 DOCUMENT NOT CONSIDERED FINAL
 UNLESS ALL SIGNATURES COMPLETED

UNLESS OTHERWISE SPECIFIED,
 HI-VISIBILITY CROSSWALK
 MARKINGS SHALL BE USED AT
 MID-BLOCK CROSSINGS

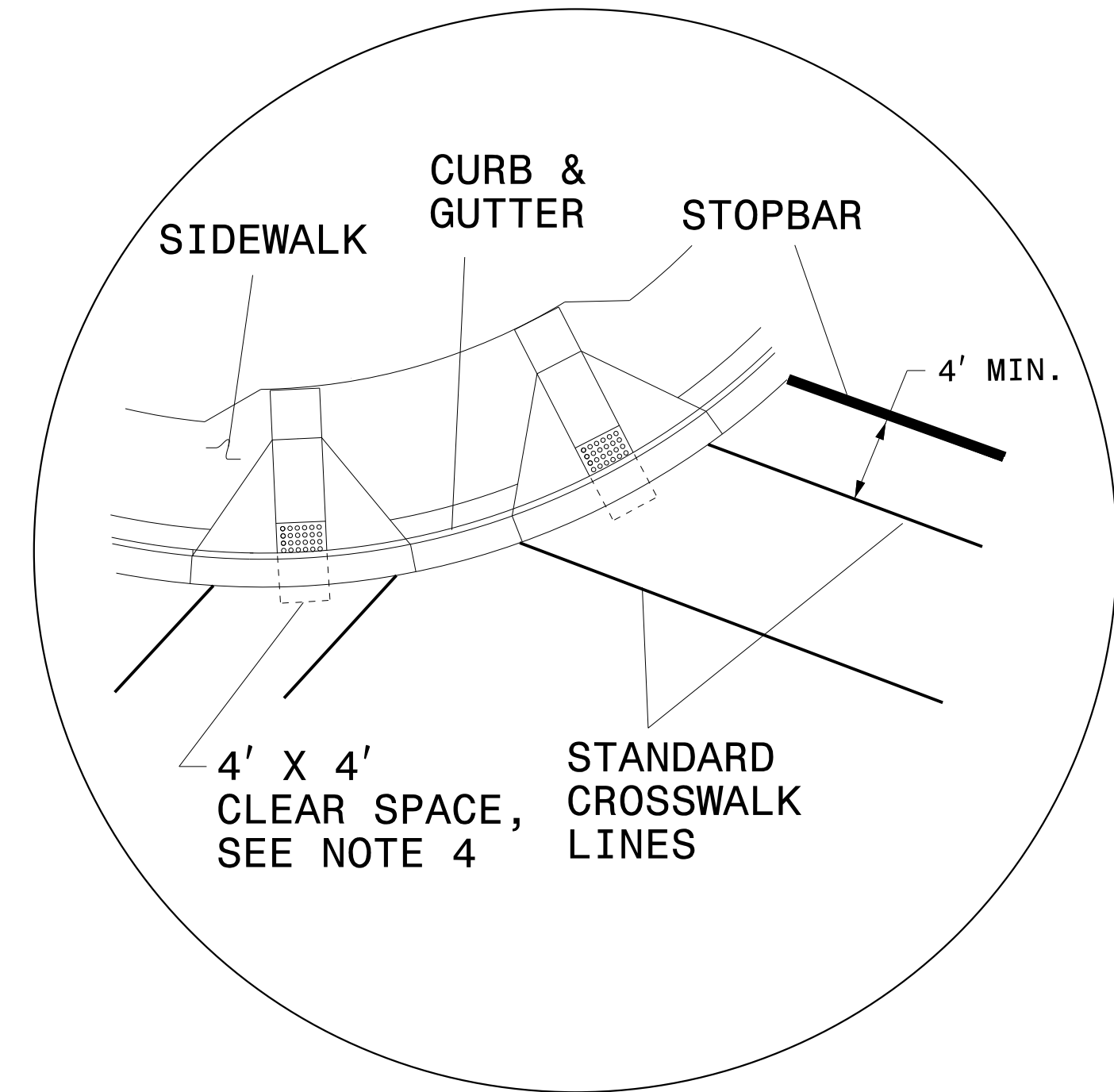
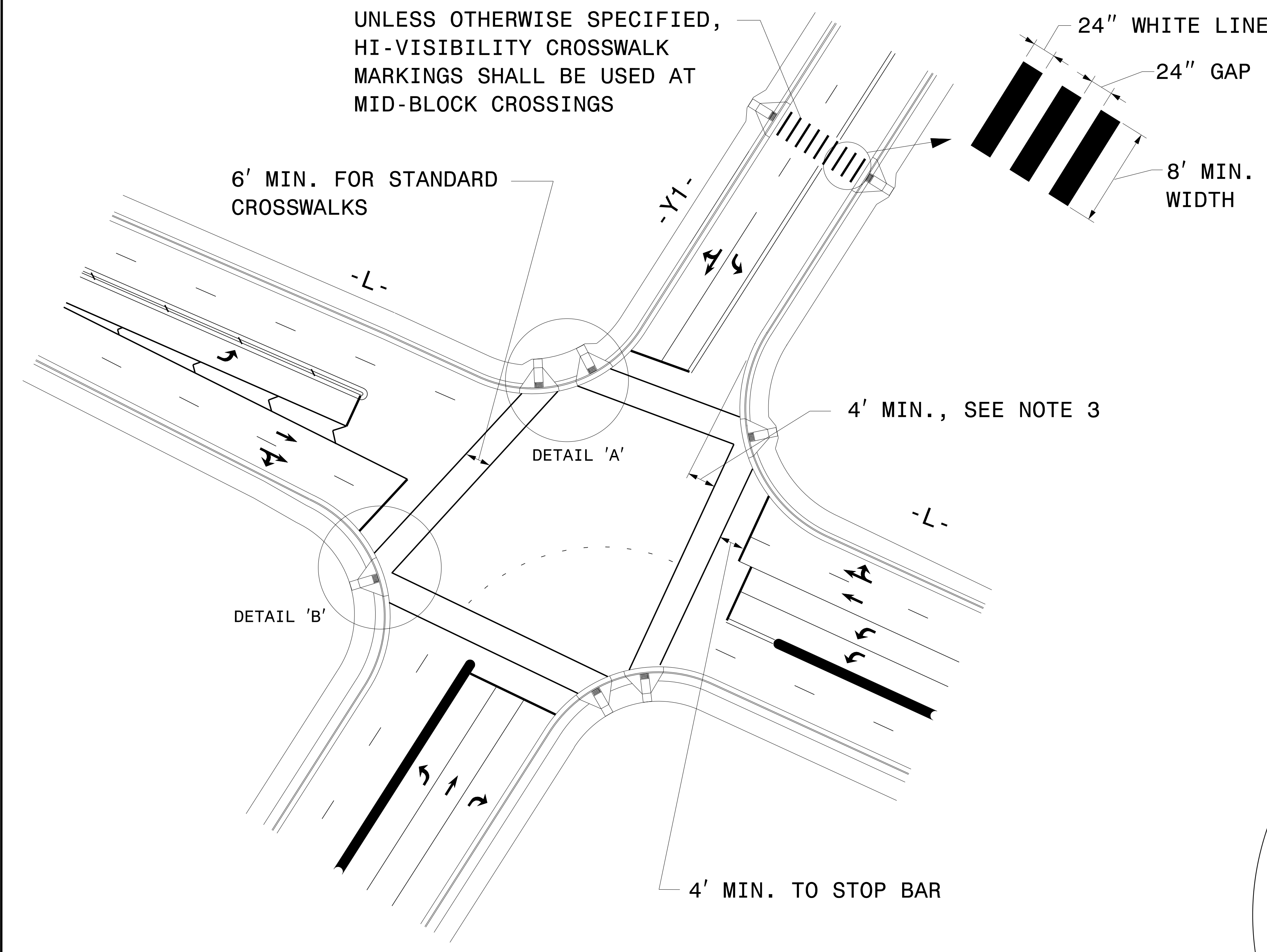

DETAIL 'A'- DUAL CURB RAMPS

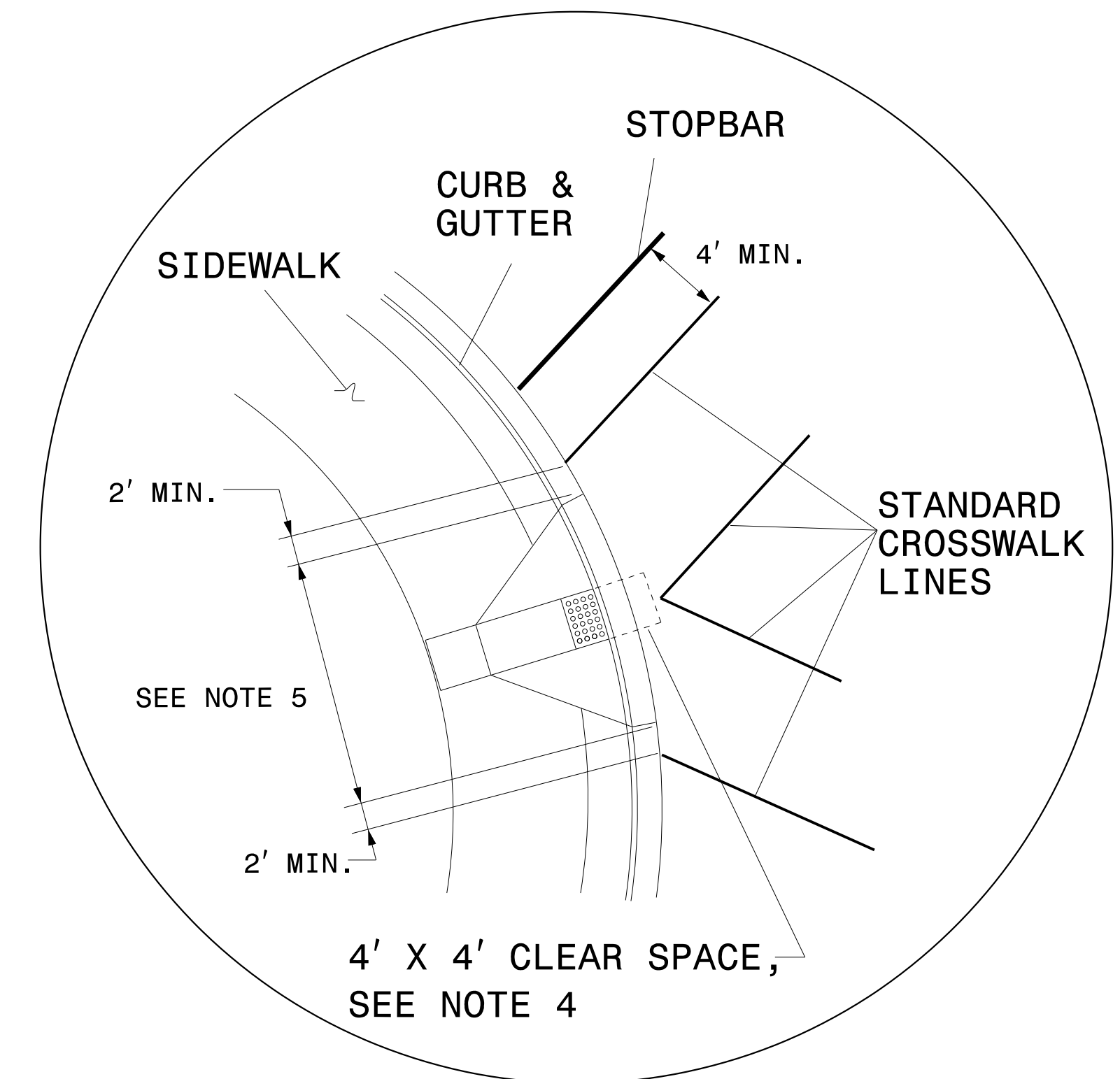

DETAIL 'B'- SINGLE DIAGONAL CURB RAMP

GUIDANCE DETAIL FOR CROSSWALK MARKINGS

NOTES:

1. USE THE DETAILS ABOVE AND THE FOLLOWING NOTES FOR GUIDANCE IN PLACING CROSSWALK MARKINGS NOT STATIONED ON THE DETAIL SHEETS OR WHEN FIELD ADJUSTMENTS REQUIRED MOVING STATIONED MARKINGS AS DIRECTED BY THE ENGINEER. REFER TO NCDOT ROADWAY STANDARD DRAWINGS, MUTCD AND ADA STANDARDS FOR ADDITIONAL GUIDANCE.
2. THE CROSSWALK MARKINGS SHOWN ON THE ABOVE DETAILS ARE FOR REFERENCE ONLY. ONLY INSTALL CROSSWALK MARKINGS WHERE SHOWN ON THE DETAIL SHEETS OR AS DIRECTED BY THE ENGINEER. THE CROSSWALK MARKING TYPE, STANDARD OR HI-VISIBILITY, SHALL BE INSTALL AS SPECIFIED ON THE DETAIL SHEETS OR AS DIRECTED BY THE ENGINEER.
3. SET BACK DISTANCE FROM INSIDE CROSSWALK MARKING TO NEAREST EDGE OF TRAVEL IS 4' MIN.
4. BEYOND THE BOTTOM GRADE BRAKE, A CLEAR SPACE OF 4' X 4' MINIMUM SHALL BE PROVIDED WITHIN THE MARKINGS.
5. SINGLE DIAGONAL CURB RAMPS WITH FLARED SIDES SHALL HAVE A SEGMENT OF CURB 2 FEET LONG MINIMUM LOCATED ON EACH SIDE OF THE CURB RAMP AND WITHIN THE MARKED CROSSING, SEE DETAIL 'B'.
6. CURB RAMPS SHALL BE CONSTRUCTED IN ACCORDANCE TO THE LATEST NCDOT ROADWAY STANDARD DRAWINGS.

**CROSSWALK PAVEMENT MARKING
 GUIDANCE DETAIL**

1/28/2016
 P:\Projects\Projects-B\B5121\Traffic\Signing\CADD\PMP\B-5121-B5317_PMP.dgn
 User: sjohns



DOCUMENT NOT CONSIDERED FINAL
 UNLESS ALL SIGNATURES COMPLETED

STATE OF NORTH CAROLINA
 DEPT. OF TRANSPORTATION
 DIVISION OF HIGHWAYS
 RALEIGH, N.C.

LANE DROP AT AN INTERSECTION

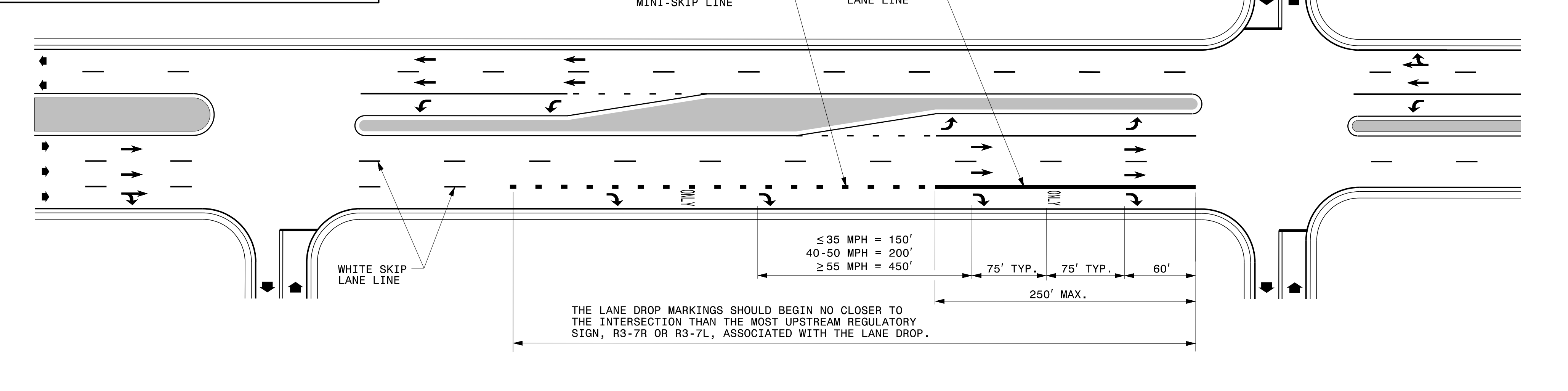

LANE DROP AT AN INTERSECTION WITH AN AUXILIARY LANE

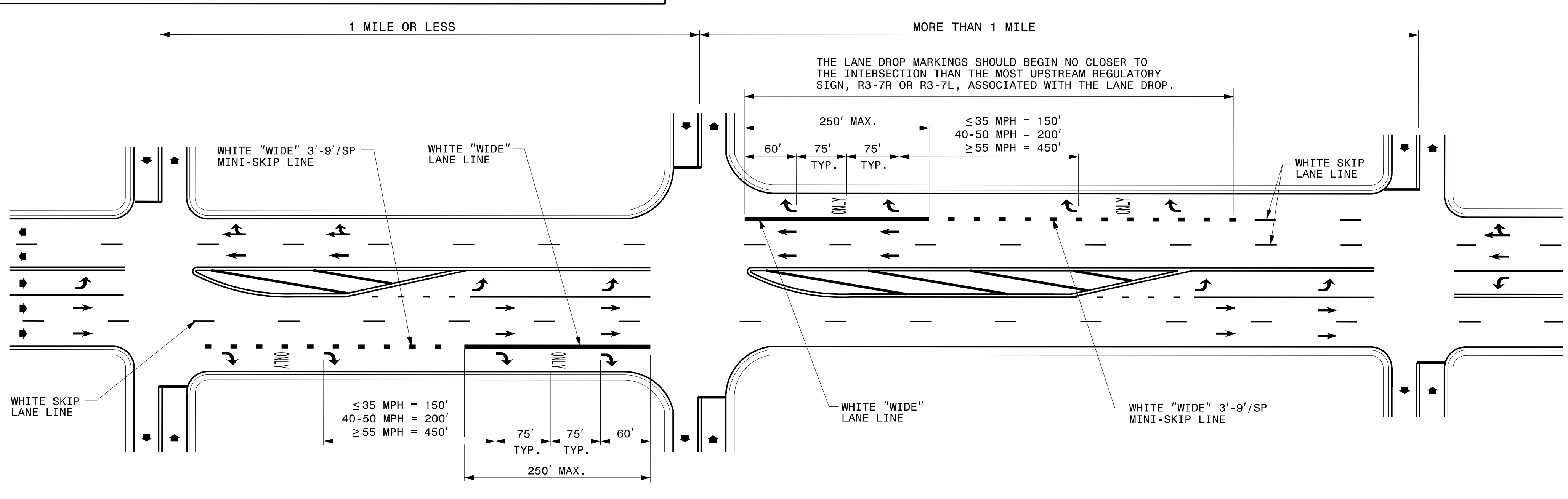

GENERAL NOTES:

- USE THE GUIDANCE SHOWN ON THE ABOVE DETAILS IN CONJUNCTION WITH INTERSECTION GUIDANCE SHOWN ON ROADWAY STANDARD DRAWING 1205.04.
- LANE LINES INDICATED AS "WIDE" SHALL BE AT LEAST TWICE THE WIDTH OF THE NORMAL LINE.

LEGEND	
W = WIDTH OF TRAVEL LANE	ONLY PAVEMENT MARKING SYMBOLS & CHARACTERS
➔ DIRECTION OF TRAFFIC FLOW	

SHEET 1 OF 3
1205D06

SHEET 1 OF 3
1205D06

ENGLISH DETAIL DRAWING FOR
PAVEMENT MARKINGS
 LANE DROPS

ENGLISH DETAIL DRAWING FOR
PAVEMENT MARKINGS
 LANE DROPS

1/28/2016
 P:\Projects\1205\1205D06.dgn
 User: sjohns

**REVISED PAVEMENT MARKING
 ROADWAY STANDARD DRAWING**

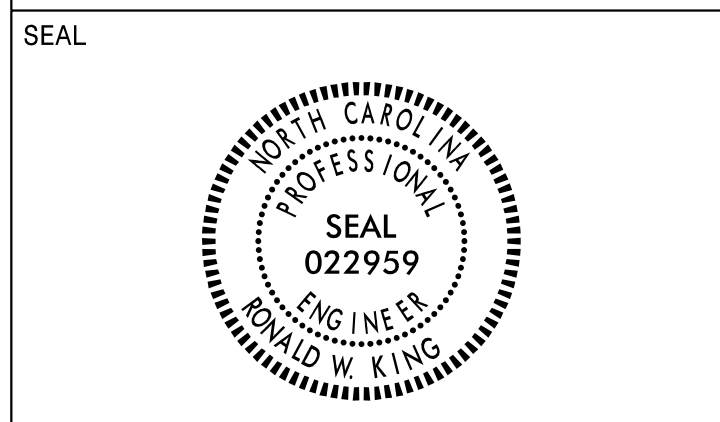

DOCUMENT NOT CONSIDERED FINAL
UNLESS ALL SIGNATURES COMPLETED

SYMBOL AND PAVEMENT MARKING LEGEND	
THERMOPLASTIC	
(T2)	WHITE STOPBAR (24")
(TA)	WHITE EDGELINE (4")
(TB)	YELLOW EDGELINE (4")
(TC)	10' WHITE SKIP (4")
(TD)	3FT.-9FT./SP WHITE MINISKIP (4")
(TE)	WHITE SOLID LANE LINE (4")
(TI)	YELLOW DOUBLE CENTER (4")
(TN)	WHITE GORE LINE (8")
(TQ)	WHITE CROSSWALK LINE (8")
(UA) LEFT TURN ARROW (UB) RIGHT TURN ARROW (UD) LEFT/STRAIGHT ARROW ONLY (UI) ALPHANUMERIC CHARACTER	

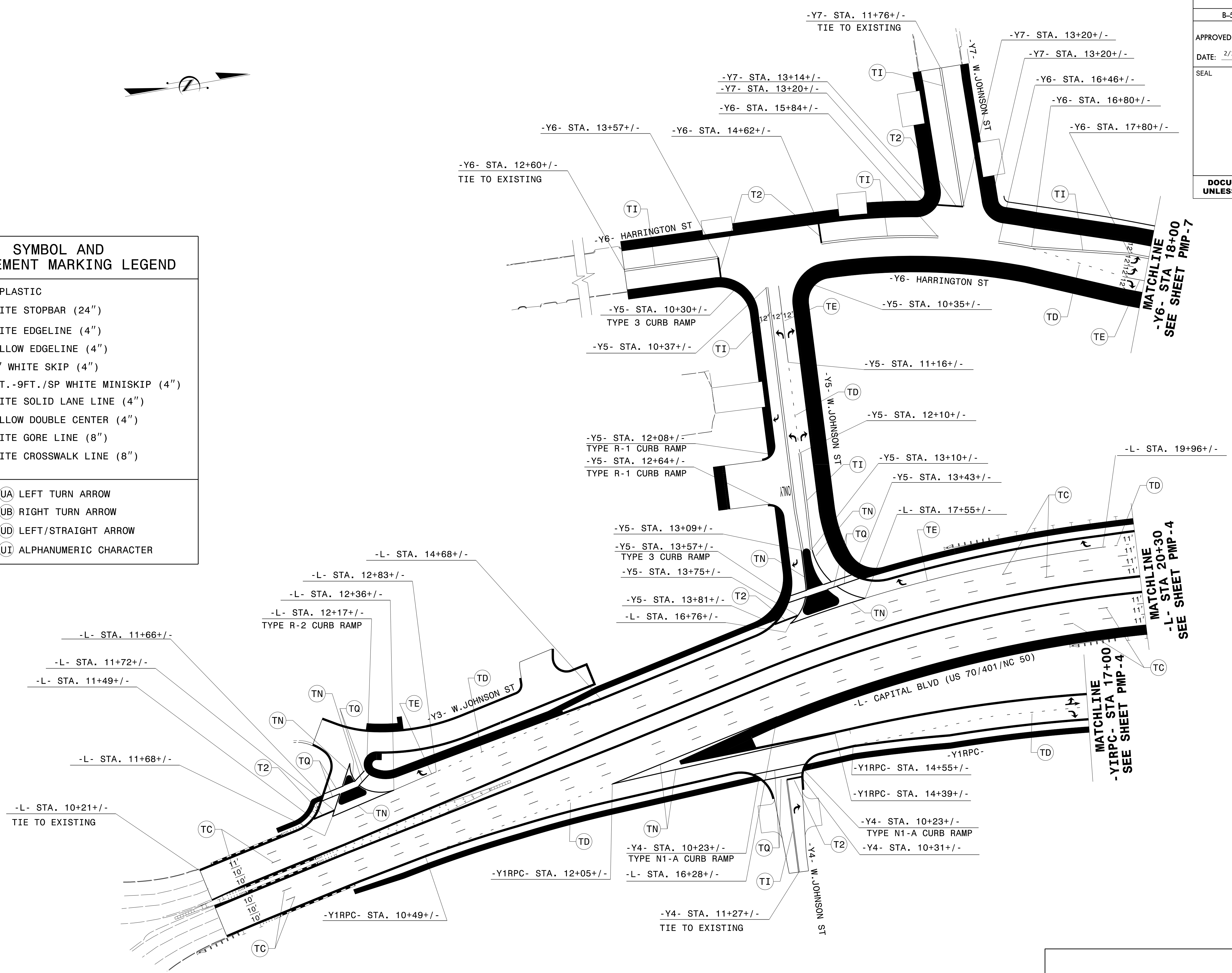

1/28/2016
 P:\IP\Projects-B\B5121\Traffic\Signing\CADD\PM\B-5121-B5317_PMP_3.dgn
 Users\johns

PAVEMENT MARKING DETAIL



DOCUMENT NOT CONSIDERED FINAL
UNLESS ALL SIGNATURES COMPLETED

SEE INSERT 'A'

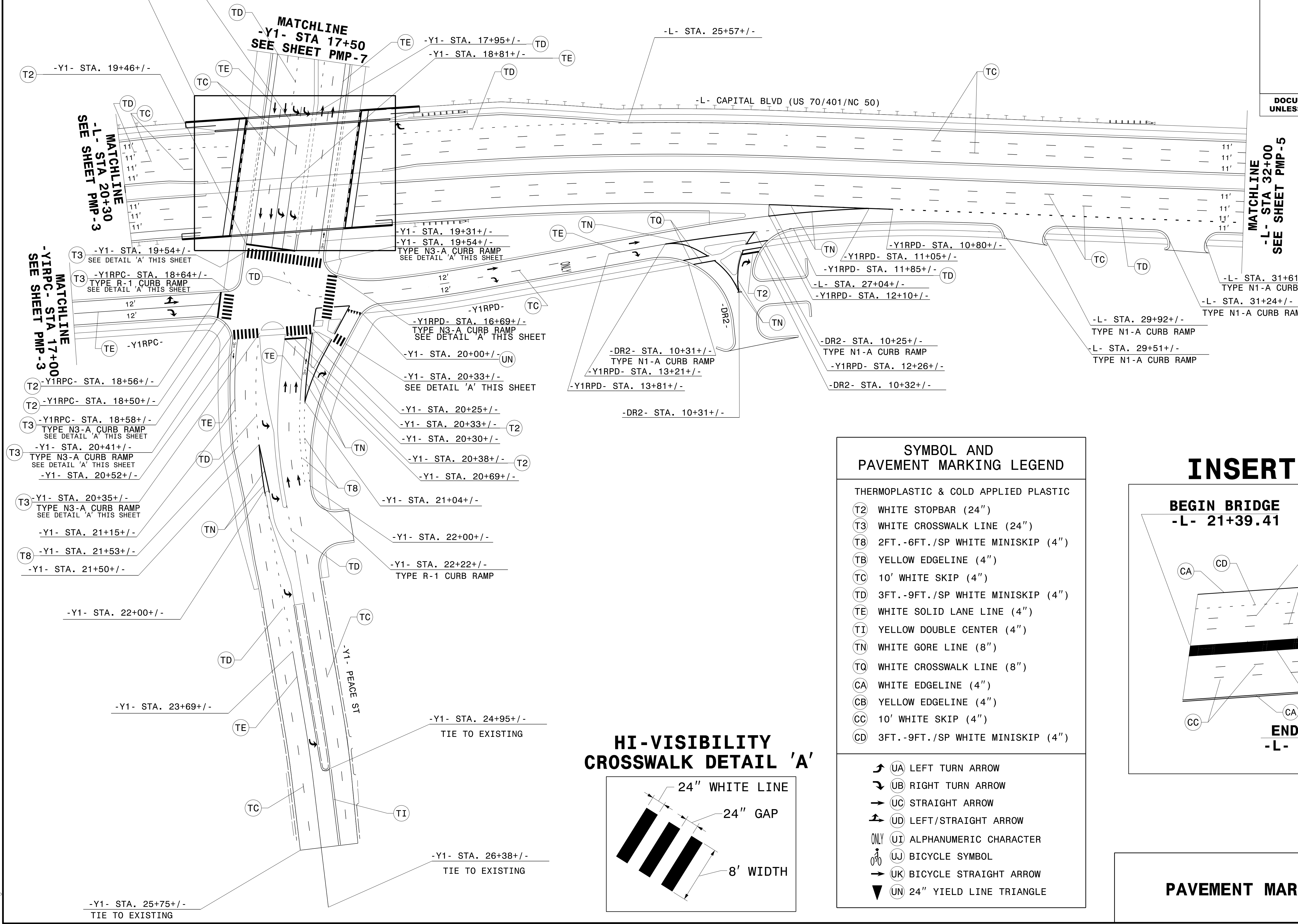

SYMBOL AND PAVEMENT MARKING LEGEND

- THERMOPLASTIC & COLD APPLIED PLASTIC
- (T2) WHITE STOPBAR (24")
 - (T3) WHITE CROSSWALK LINE (24")
 - (T8) 2FT.-6FT./SP WHITE MINISKIP (4")
 - (TB) YELLOW EDGELINE (4")
 - (TC) 10' WHITE SKIP (4")
 - (TD) 3FT.-9FT./SP WHITE MINISKIP (4")
 - (TE) WHITE SOLID LANE LINE (4")
 - (TI) YELLOW DOUBLE CENTER (4")
 - (TN) WHITE GORE LINE (8")
 - (TQ) WHITE CROSSWALK LINE (8")
 - (CA) WHITE EDGELINE (4")
 - (CB) YELLOW EDGELINE (4")
 - (CC) 10' WHITE SKIP (4")
 - (CD) 3FT.-9FT./SP WHITE MINISKIP (4")
- ↶ (UA) LEFT TURN ARROW
 - ↷ (UB) RIGHT TURN ARROW
 - (UC) STRAIGHT ARROW
 - ↶ (UD) LEFT/STRAIGHT ARROW
 - ONLY (UI) ALPHANUMERIC CHARACTER
 - 🚲 (UJ) BICYCLE SYMBOL
 - (UK) BICYCLE STRAIGHT ARROW
 - ▼ (UN) 24" YIELD LINE TRIANGLE

HI-VISIBILITY CROSSWALK DETAIL 'A'

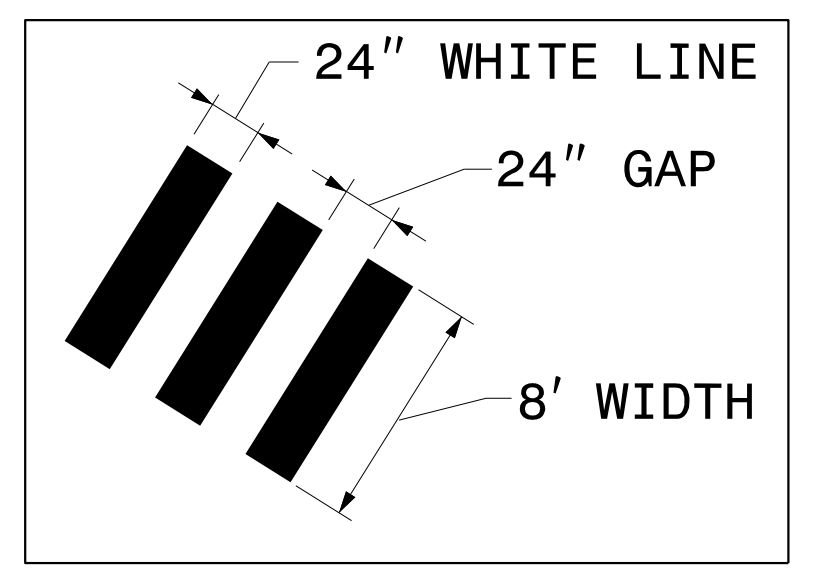

INSERT 'A'

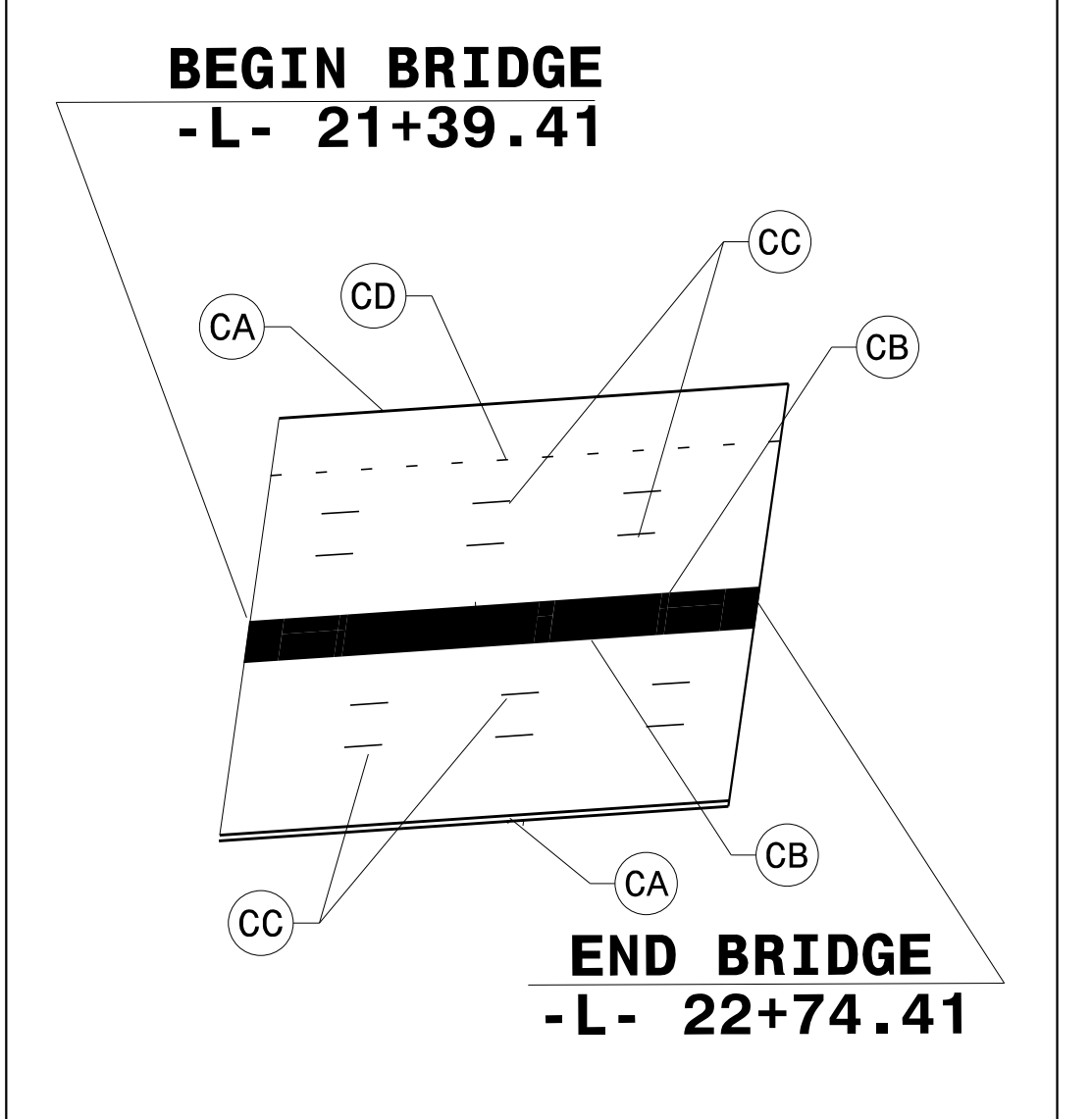

PAVEMENT MARKING DETAIL

2/1/2016 P:\TIP-Proj\Projects-B\5121\Traffic\Signing\CADD\PM\B-5121-B5317_PMP_4.dgn Users:johns

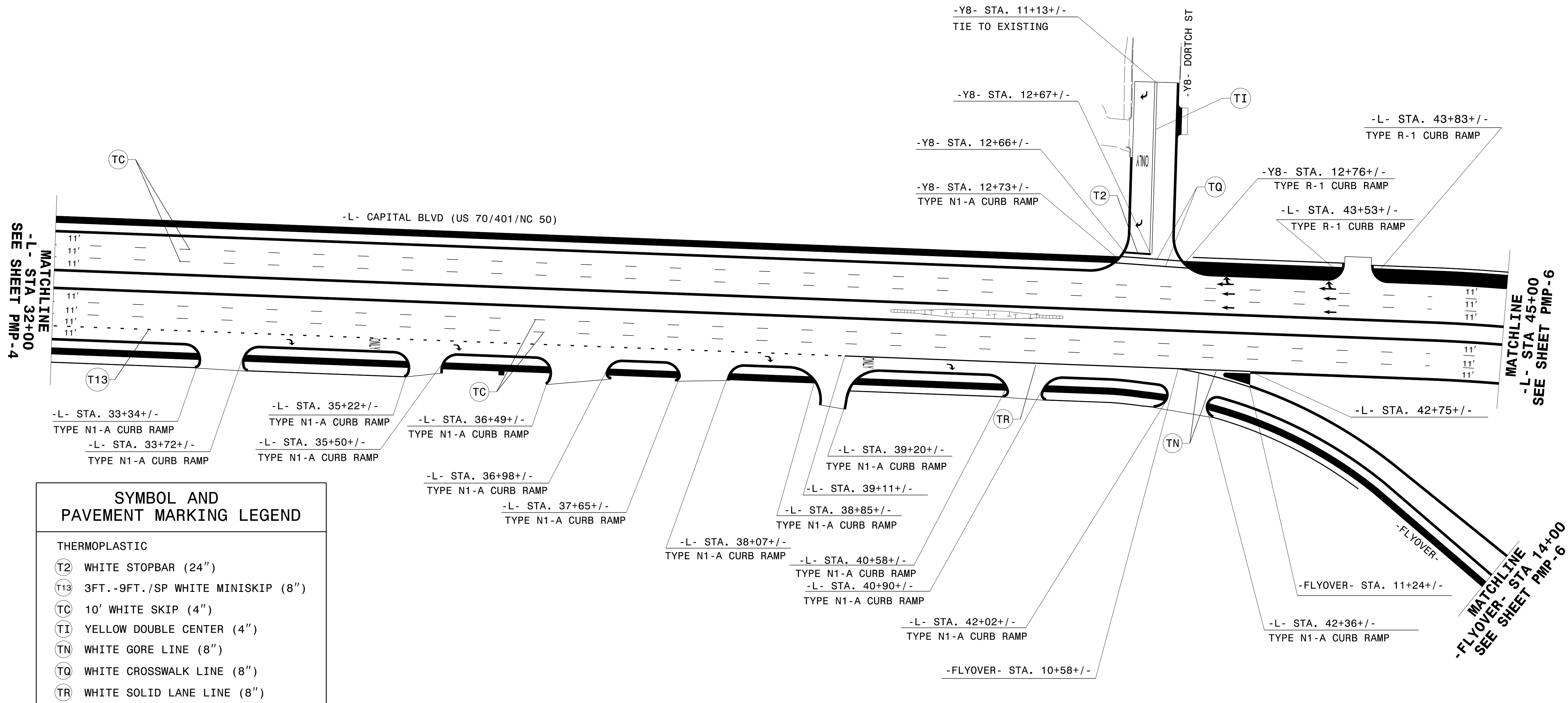

SYMBOL AND PAVEMENT MARKING LEGEND	
THERMOPLASTIC	
(T2)	WHITE STOPBAR (24")
(T13)	3FT.-9FT./SP WHITE MINISKIP (8")
(TC)	10' WHITE SKIP (4")
(T1)	YELLOW DOUBLE CENTER (4")
(TN)	WHITE GORE LINE (8")
(TQ)	WHITE CROSSWALK LINE (8")
(TR)	WHITE SOLID LANE LINE (8")
↘ (UB)	RIGHT TURN ARROW
→ (UC)	STRAIGHT ARROW
↗ (UE)	RIGHT/STRAIGHT ARROW
ONLY (UI)	ALPHANUMERIC CHARACTER

1/28/2016
 P:\IP\Projects-B\5121\Traffic\Signing\CADD\PM\B-5121-B5317_PMP_5.dgn
 Users\johns

PAVEMENT MARKING DETAIL

SEAL

**DOCUMENT NOT CONSIDERED FINAL
 UNLESS ALL SIGNATURES COMPLETED**

SYMBOL AND PAVEMENT MARKING LEGEND	
THERMOPLASTIC & COLD APPLIED PLASTIC	
(T2)	WHITE STOPBAR (24")
(T3)	WHITE CROSSWALK LINE (24")
(TC)	10' WHITE SKIP (4")
(TD)	3FT.-9FT./SP WHITE MINISKIP (4")
(TE)	WHITE SOLID LANE LINE (4")
(TN)	WHITE GORE LINE (8")
(TQ)	WHITE CROSSWALK LINE (8")
(CA)	WHITE EDGELINE (4")
↘ (UB)	RIGHT TURN ARROW
→ (UC)	STRAIGHT ARROW

HI-VISIBILITY CROSSWALK DETAIL 'A'

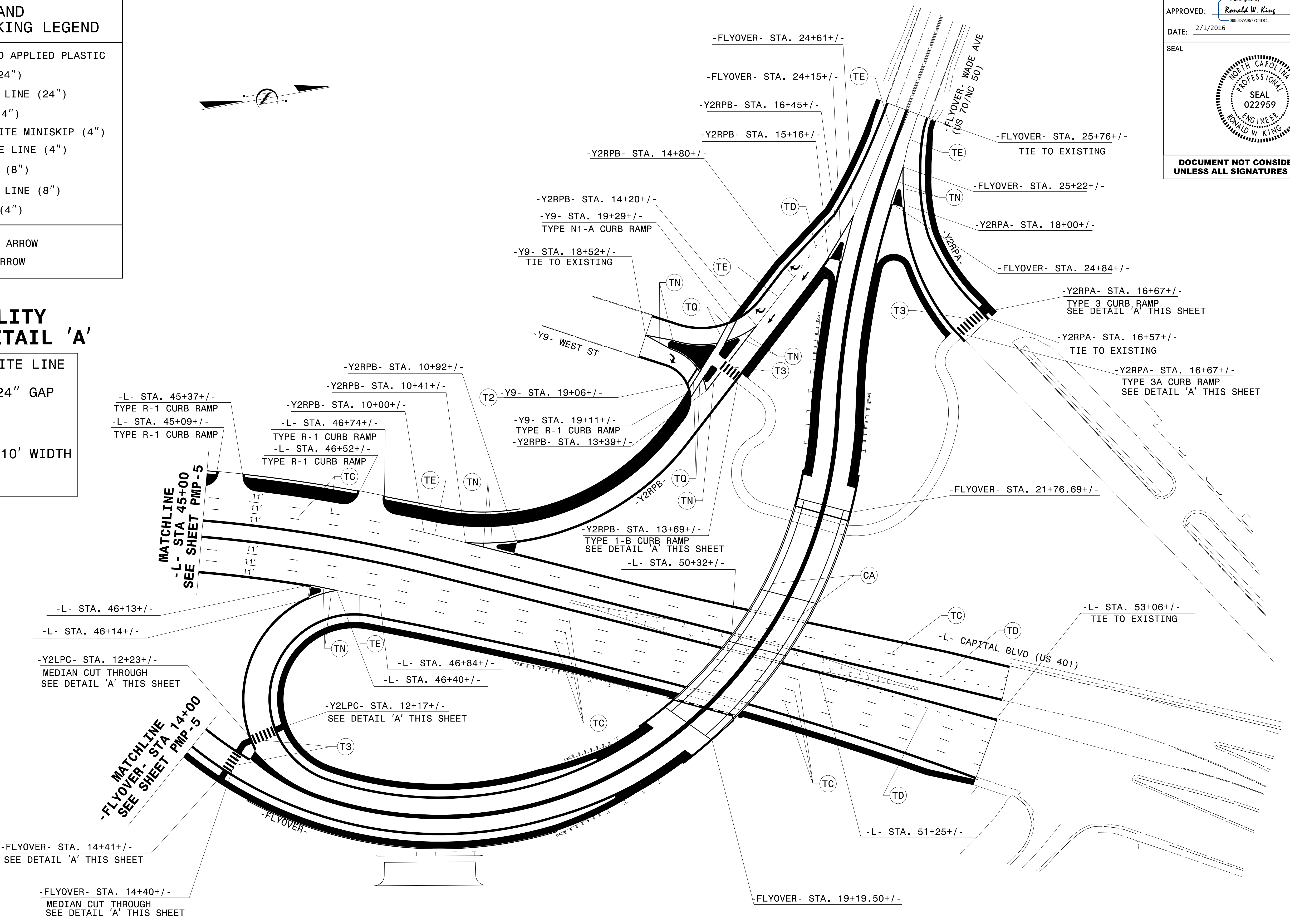
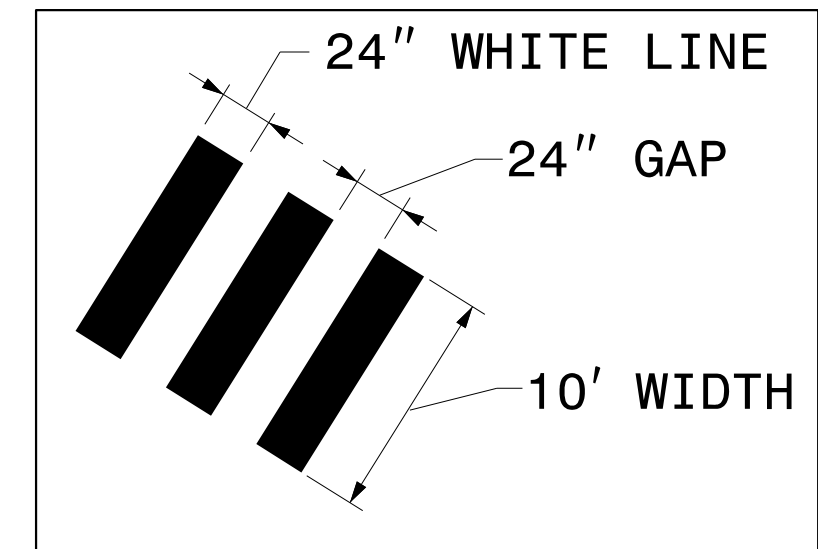

I:\28\2016\Projects-B\B5121\Traffic\Signing\CADD\PM\B-5121-B5317_PMP-6.dgn
 Users\johns

PAVEMENT MARKING DETAIL



DOCUMENT NOT CONSIDERED FINAL
UNLESS ALL SIGNATURES COMPLETED



HI-VISIBILITY CROSSWALK DETAIL 'A'

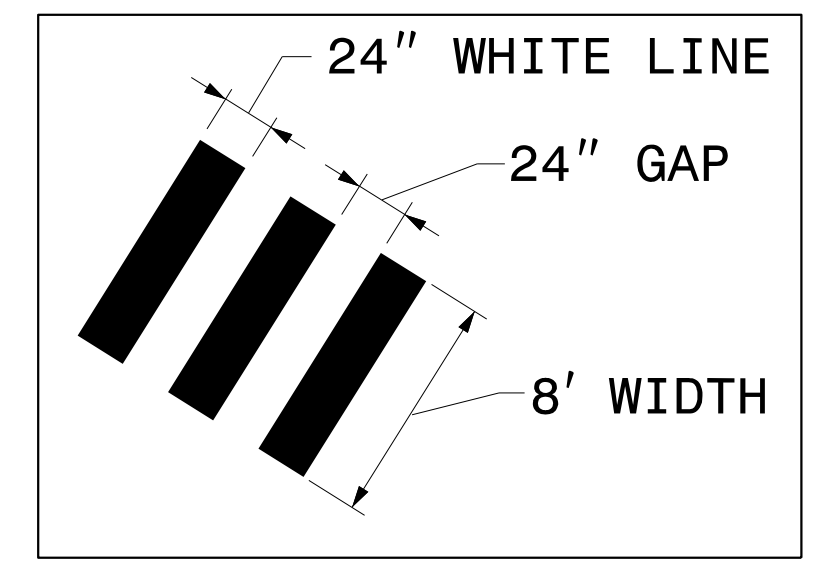

SYMBOL AND PAVEMENT MARKING LEGEND

THERMOPLASTIC	
(T2)	WHITE STOPBAR (24")
(T3)	WHITE CROSSWALK LINE (24")
(T8)	2FT.-6FT./SP WHITE MINISKIP (4")
(TC)	10' WHITE SKIP (4")
(TD)	3FT.-9FT./SP WHITE MINISKIP (4")
(TE)	WHITE SOLID LANE LINE (4")
(TF)	10' YELLOW SKIP (4")
(TH)	YELLOW SINGLE CENTER (4")
(TI)	YELLOW DOUBLE CENTER (4")
(UA)	LEFT TURN ARROW
(UB)	RIGHT TURN ARROW
(UD)	RIGHT/STRAIGHT ARROW
(UC)	STRAIGHT ARROW
(UJ)	BICYCLE SYMBOL
(UK)	BICYCLE STRAIGHT ARROW

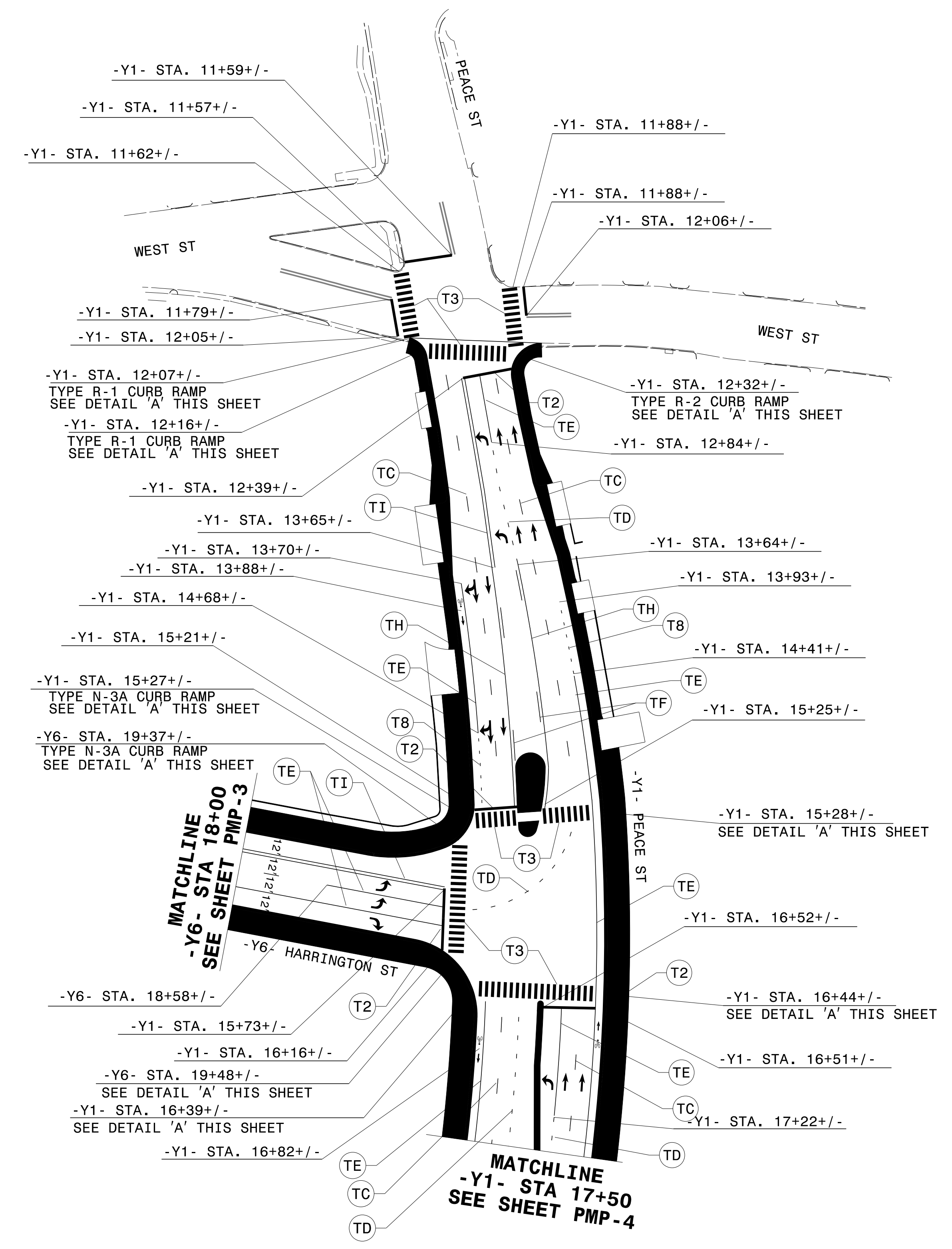

PAVEMENT MARKING DETAIL

1/28/2016
 P:\IP\Projects-B\5121\Traffic\Signing\CADD\PM\B-5121-B5317_PMP-7.dgn
 Users\johns