

**EDI MODEL 2018ECL-NC CONFLICT MONITOR PROGRAMMING DETAIL**  
(remove jumpers and set switches as shown)

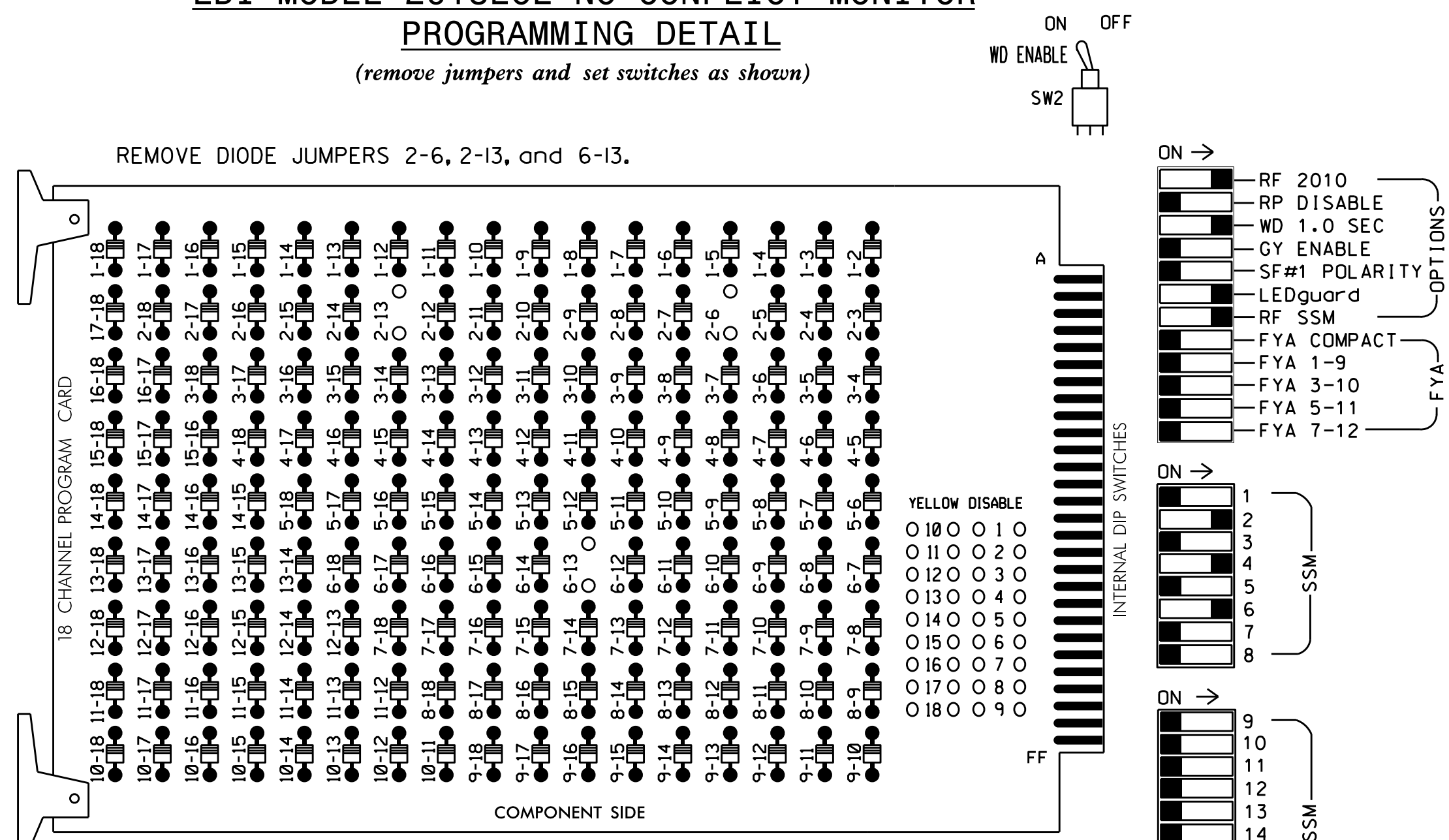

- NOTES:
- Card is provided with all diode jumpers in place. Removal of any jumper allows its channels to run concurrently.
  - Ensure jumpers SEL2-SEL5 and SEL9 are present on the monitor board.
  - Ensure that Red Enable is active at all times during normal operation.
  - Connect serial cable from conflict monitor to comm. port 1 of 2070 controller. Ensure conflict monitor communicates with 2070.

- NOTES**
- To prevent "flash-conflict" problems, insert red flash program blocks for all unused vehicle load switches in the output file. The installer shall verify that signal heads flash in accordance with the Signal Plans.
  - Program controller to start up in phases 2 and 6 green.
  - Enable simultaneous gap-out feature, on controller unit, for all phases.
  - The cabinet and controller are part of the Raleigh Signal System.

**SIGNAL HEAD HOOK-UP CHART**

LOAD SWITCH NO.	S1	S2	S3	S4	S5	S6	S7	S8	S9	S10	S11	S12
CMU CHANNEL NO.	1	2	13	3	4	14	5	6	15	7	8	16
PHASE	1	2	2 PED	3	4	4 PED	5	6	6 PED	7	8	OLG
SIGNAL HEAD NO.	NU	21,22 25	P21, P22	NU	41,42	NU	NU	61,62	NU	NU	NU	ADVANCE BEACON
RED		128			101			134				
YELLOW		129			102			135				
GREEN		130			103			136				
RED ARROW												
YELLOW ARROW												
GREEN ARROW												
Hand icon			113									** 110
PED YELLOW												** 111
Walking person icon			115									*

**EQUIPMENT INFORMATION**

CONTROLLER.....2070  
 CABINET.....332  
 SOFTWARE.....SE-PAC2070  
 CABINET MOUNT.....BASE  
 OUTPUT FILE POSITIONS...12  
 LOAD SWITCHES USED.....S2,S3,S5,S8,S12\*  
 PHASES USED.....2,2PED,4,6  
 OVERLAP "G".....2

\* Used for Advance Beacons. See sheet 3 for details.

NU = Not Used  
 \* Denotes install load resistor. See load resistor installation detail this sheet.  
 \*\* Used for Advance Beacon control. See sheet 3 for Advance Beacon Relay Control and Sign Wiring Detail.

**INPUT FILE POSITION LAYOUT (front view)**

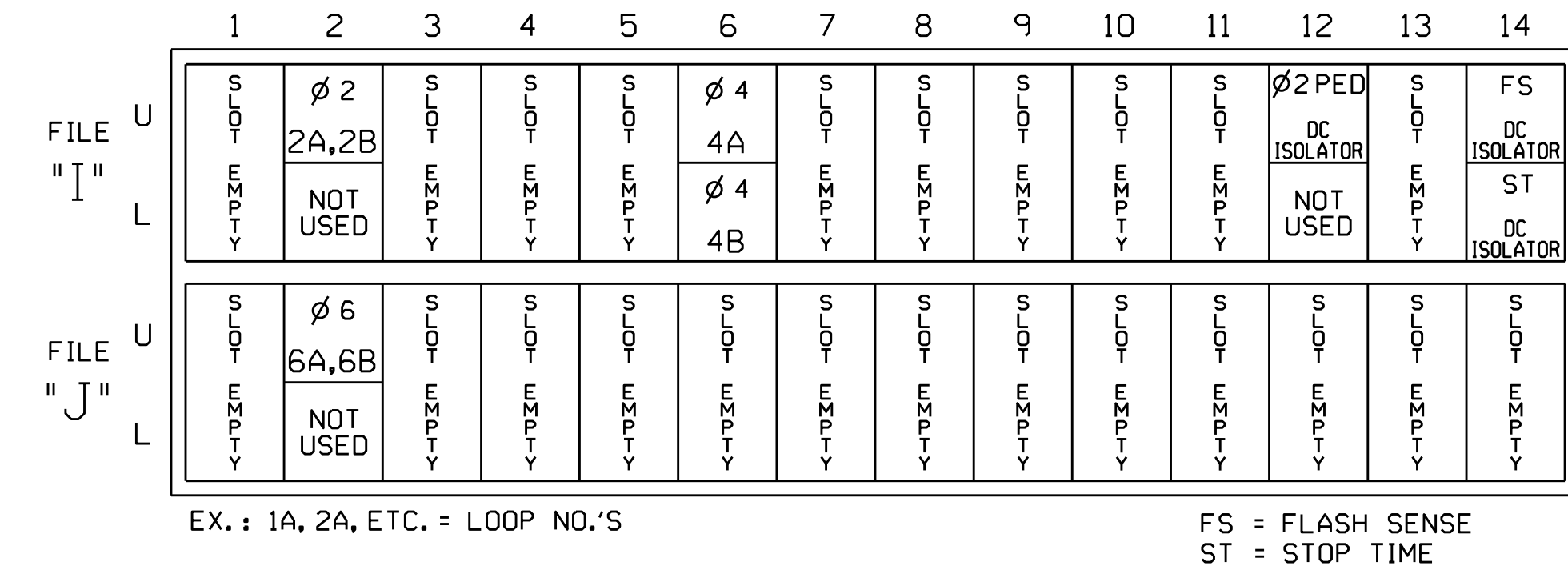

**COUNTDOWN PEDESTRIAN SIGNAL OPERATION**

Countdown Ped Signals are required to display timing only during Ped Clearance Interval. Consult Ped Signal Module user's manual for instructions on selecting this feature.

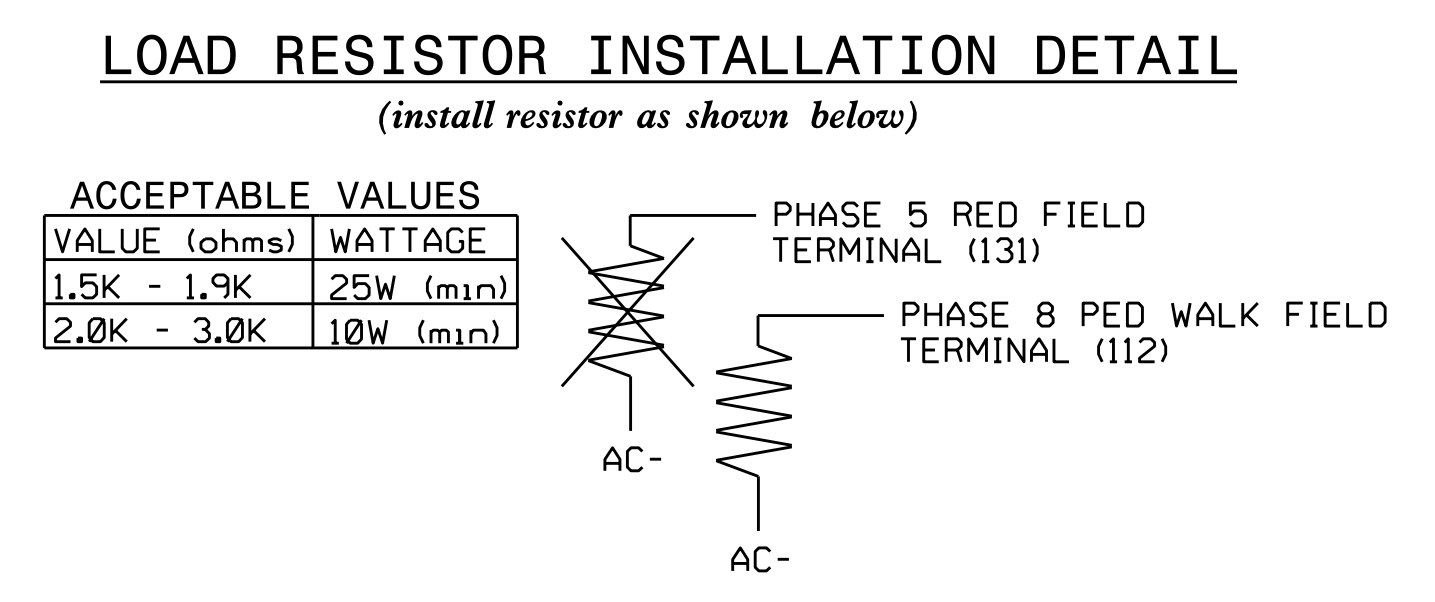

**IMPORTANT!** Remove load resistor from OLF Red field terminal, if present, as shown above.

**INPUT FILE CONNECTION & PROGRAMMING CHART**

LOOP NO.	LOOP TERMINAL	INPUT FILE POS.	PIN NO.	DETECTOR NO.	NEMA PHASE	DELAY TIME	EXTEND (STRETCH) TIME
2A,2B	TB2-5,6	I2U	39	3	2		
4A	TB4-9,10	I6U	41	11	4		
4B	TB4-11,12	I6L	45	12	4	15	
6A,6B	TB3-5,6	J2U	40	21	6		
PED PUSH BUTTONS							
P21,P22	TB8-4,6	I12U	67	PED 2	2 PED		

NOTE:  
INSTALL DC ISOLATOR IN INPUT FILE SLOT I12.

**IMPORTANT!** Remove the following jumper, if currently installed: from J1-W to I4-W on rear of Input File.

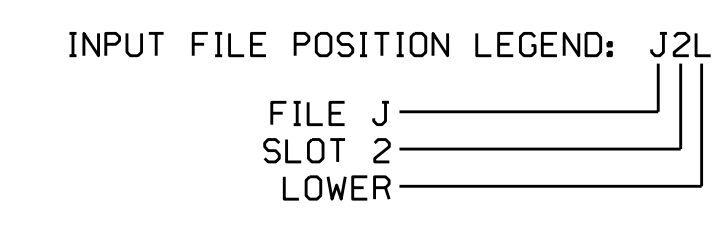

THIS ELECTRICAL DETAIL IS FOR THE SIGNAL DESIGN: 05-1642T5  
 DESIGNED: December 2015  
 SEALED: 2/1/2016  
 REVISED: N/A

**DOCUMENT NOT CONSIDERED FINAL UNLESS ALL SIGNATURES COMPLETED**

Electrical Detail - Temp Design 5 (TMP Area II Phase IV, Step 3) - Sheet 1 of 3

ELECTRICAL AND PROGRAMMING DETAILS FOR: Prepared in the Offices of: Signal Management Systems, Inc. 750 Greenfield Parkway, Garner, NC 27529	W. Peace Street at US 70 WB-401/NC 50 NB (Capital Blvd.) Ramps		SEAL KEITH M. MIMS ENGINEER
	Division 5 Wake County Raleigh PLAN DATE: January 2016 REVIEWED BY: T. Joyce PREPARED BY: S. Armstrong REVIEWED BY:	REVISIONS INIT. DATE	

DocuSigned by:  
 Keith M. Mims 2/2/2016  
 2F8079E8C8D364S  
 DATE  
 SIG. INVENTORY NO. 05-1642T5

09-SEP-2016 10:10  
 S:\MITSAS\115\_Signal\workgroups\Sig\_Mgmt\mstron051642\_sm.elec.xxx.dgn  
 somstron