

**This electronic collection of documents is provided
for the convenience of the user
and is Not a Certified Document –**

**The documents contained herein were originally issued
and sealed by the individuals whose names and license
numbers appear on each page, on the dates appearing
with their signature on that page.**

**This file or an individual page
shall not be considered a certified document.**

STATE OF NORTH CAROLINA
DIVISION OF HIGHWAYS

TRANSPORTATION MANAGEMENT PLAN

DURHAM COUNTY

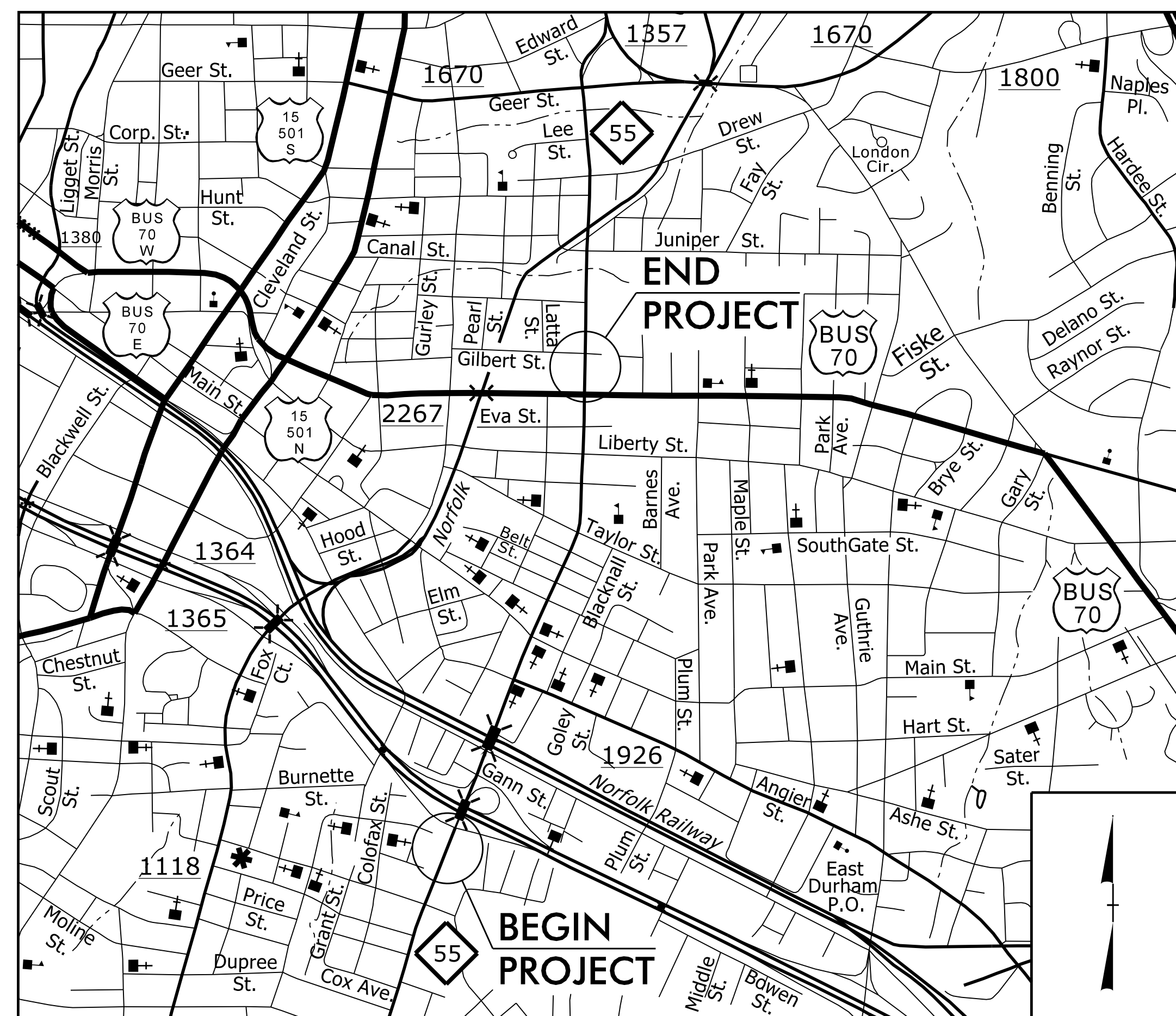
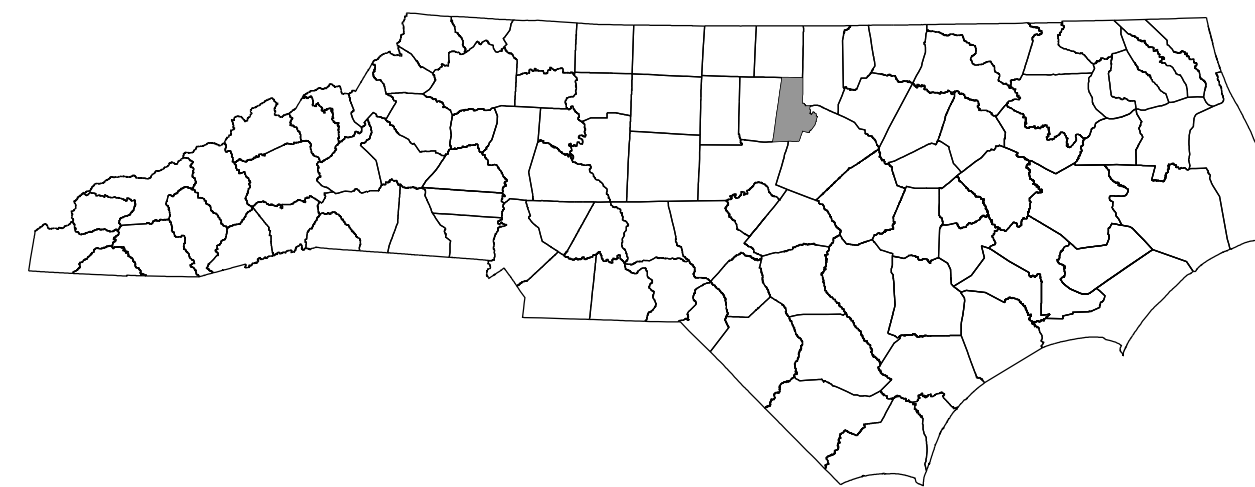

VICINITY MAP
(NOT TO SCALE)

SHEET NO.	TITLE
TMP-1	TITLE SHEET AND INDEX OF SHEETS
TMP-1A	LIST OF APPLICABLE ROADWAY STANDARD DRAWINGS AND LEGEND
TMP-2 AND TMP-2A	PROJECT NOTES
TMP-2B	TEMPORARY SHORING DATA
TMP-2C	ROAD AND SIDEWALK CLOSURE LEGEND
TMP-2D THRU TMP-2W	DETOUR ROUTES
TMP-2X THRU TMP-2AB	PEDESTRIAN DETOUR
TMP-2AC THRU TMP-2AT	SPECIAL SIGN DESIGNS
TMP-2AU	PCB AT TEMPORARY SHORING LOCATIONS
TMP-2AV	DETOUR ROUTES
TMP-3 THRU TMP-3E	TEMPORARY TRAFFIC CONTROL PHASING
TMP-4 THRU TMP-4C	TYPICAL SECTIONS
TMP-5 THRU TMP-8	TEMPORARY TRAFFIC CONTROL DETAILS: PHASE 1 - STEPS 1 - 10 (INCLUDING TMP-5A: PHASE 1 - STEP 4A)
TMP-9 THRU TMP-12	TEMPORARY TRAFFIC CONTROL DETAILS: PHASE 1 - STEPS 11 - 21
TMP-13	TEMPORARY TRAFFIC CONTROL DETAILS: PHASE 1 - STEP 15
TMP-14	TEMPORARY TRAFFIC CONTROL DETAILS: PHASE 1 - STEP 16
TMP-15 THRU TMP-18	TEMPORARY TRAFFIC CONTROL DETAILS: PHASE 2 - STEPS 1 - 6
TMP-19 THRU TMP-22	TEMPORARY TRAFFIC CONTROL DETAILS: PHASE 2 - STEPS 7 - 11
TMP-23 AND TMP-24	TEMPORARY TRAFFIC CONTROL DETAILS: PHASE 2 - STEP 10
TMP-25 THRU TMP-28	TEMPORARY TRAFFIC CONTROL DETAILS: PHASE 3

PLAN PREPARED BY:

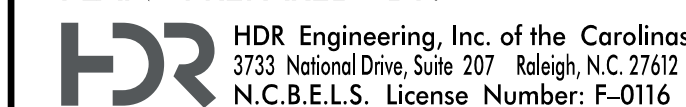

HDR Engineering, Inc. of the Carolinas
3733 National Drive, Suite 207 Raleigh, NC 27612
N.C.B.E.L.S. License Number: F-0116

MICHELLE WARD, P.E. *TRAFFIC CONTROL PROJECT ENGINEER*

R. ERSKINE BROOKS, P.E. *TRAFFIC CONTROL PROJECT DESIGN ENGINEER*

CHRIS HARNDEN *TRAFFIC CONTROL DESIGN ENGINEER*

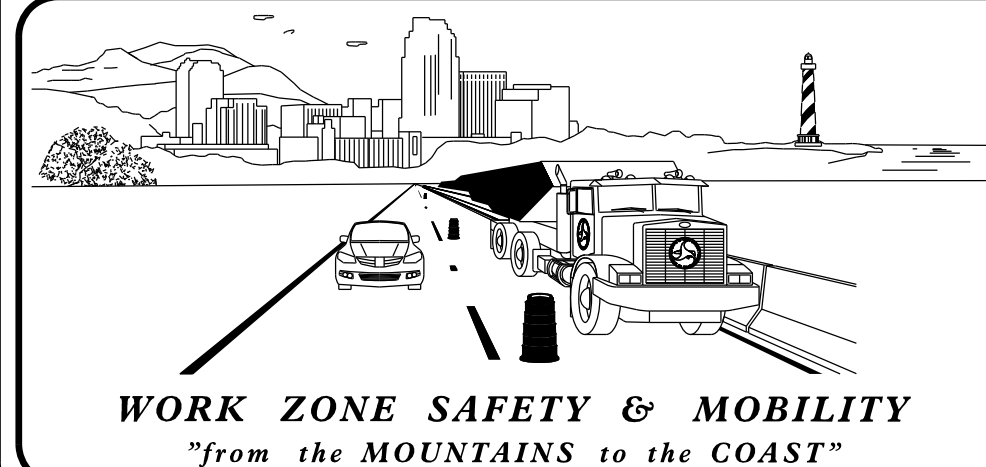

WORK ZONE SAFETY & MOBILITY
"from the MOUNTAINS to the COAST"

N.C.D.O.T. WORK ZONE TRAFFIC CONTROL
1561 MAIL SERVICE CENTER (MSC) RALEIGH, NC 27699-1561
750 N. GREENFIELD PARKWAY, GARNER, NC 27529 (DELIVERY)
PHONE: (919) 773-2800 FAX: (919) 771-2745

J. S. BOURNE, P.E. *STATE TRAFFIC MANAGEMENT ENGINEER*

DAVID BISSETTE, P.E. *TRAFFIC CONTROL PROJECT ENGINEER*

MIKE STEELMAN *TRAFFIC CONTROL PROJECT DESIGN ENGINEER*

ALLEN HAYES, E.I. *TRAFFIC CONTROL DESIGN ENGINEER*



DOCUMENT NOT CONSIDERED FINAL
UNLESS ALL SIGNATURES COMPLETED

APPROVED: R. Erskine Brooks
DATE: 5/13/2016

SEAL













ROADWAY STANDARD DRAWINGS

THE FOLLOWING ROADWAY STANDARDS AS SHOWN IN "ROADWAY STANDARD DRAWINGS" - PROJECT SERVICES UNIT - N.C. DEPARTMENT OF TRANSPORTATION - RALEIGH, N.C., DATED JANUARY 2012 ARE APPLICABLE TO THIS PROJECT AND BY REFERENCE HEREBY ARE CONSIDERED A PART OF THESE PLANS:



STD. NO.	TITLE
1101.01	WORK ZONE WARNING SIGNS
1101.02	TEMPORARY LANE CLOSURES
1101.03	TEMPORARY ROAD CLOSURES
1101.04	TEMPORARY SHOULDER CLOSURES
1101.11	TRAFFIC CONTROL DESIGN TABLES
1110.01	STATIONARY WORK ZONE SIGNS
1110.02	PORTABLE WORK ZONE SIGNS
1115.01	FLASHING ARROW BOARDS
1130.01	DRUMS
1135.01	CONES
1145.01	BARRICADES
1150.01	FLAGGING DEVICES
1160.01	TEMPORARY CRASH CUSHION
1165.01	WORK VEHICLE LIGHTING SYSTEMS AND TMA DELINEATION
1170.01	PORTABLE CONCRETE BARRIER
1180.01	SKINNY - DRUM
1205.01	PAVEMENT MARKINGS - LINE TYPES AND OFFSETS
1205.02	PAVEMENT MARKINGS - TWO LANE AND MULTILANE ROADWAYS
1205.03	PAVEMENT MARKINGS - EXITS AND ENTRANCE RAMP
1205.04	PAVEMENT MARKINGS - INTERSECTIONS
1205.05	PAVEMENT MARKINGS - TURN LANES
1205.06	PAVEMENT MARKINGS - LANE DROPS
1205.07	PAVEMENT MARKINGS - PEDESTRIAN CROSSWALKS
1205.08	PAVEMENT MARKINGS - SYMBOLS AND WORD MESSAGES
1205.09	PAVEMENT MARKINGS - PAINTED ISLANDS
1205.10	PAVEMENT MARKINGS - SCHOOL AREAS
1205.12	PAVEMENT MARKINGS - BRIDGES
1250.01	RAISED PAVEMENT MARKERS - INSTALLATION SPACING
1251.01	RAISED PAVEMENT MARKERS - PERMANENT AND TEMPORARY
1261.01	GUARDRAIL AND BARRIER DELINEATORS - INSTALLATION SPACING
1261.02	GUARDRAIL AND BARRIER DELINEATORS - TYPES AND MOUNTING
1262.01	GUARDRAIL END DELINEATION
1264.01	OBJECT MARKERS - TYPES
1264.02	OBJECT MARKERS - INSTALLATION

LEGEND

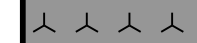
GENERAL

-  DIRECTION OF TRAFFIC FLOW
-  DIRECTION OF PEDESTRIAN TRAFFIC FLOW
-  EXIST. PVMT.
-  NORTH ARROW
-  PROPOSED PVMT.
-  TEMP. SHORING (LOCATION PURPOSES ONLY)
-  WORK AREA
-  ON-GOING CONSTRUCTION
-  WEDGING
-  TEMPORARY PAVEMENT
-  REMOVAL











SIGNALS

-  EXISTING
-  PROPOSED
-  TEMPORARY



PAVEMENT MARKINGS

-  EXISTING LINES
-  TEMPORARY LINES

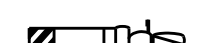

TRAFFIC CONTROL DEVICES

-  BARRICADE (TYPE III)
-  CONE
-  DRUM
-  SKINNY DRUM
-  TUBULAR MARKER
-  TEMPORARY CRASH CUSHION
-  FLASHING ARROW PANEL (TYPE C)
-  FLAGGER
-  LAW ENFORCEMENT
-  TRUCK MOUNTED IMPACT ATTENUATOR (TMIA)
-  CHANGEABLE MESSAGE SIGN

TEMPORARY SIGNING

-  PORTABLE SIGN
-  STATIONARY SIGN
-  STATIONARY OR PORTABLE SIGN

PAVEMENT MARKERS





-  CRYSTAL / CRYSTAL
-  CRYSTAL / RED
-  YELLOW / YELLOW

PAVEMENT MARKING SYMBOLS

-  PAVEMENT MARKING SYMBOLS

TEMPORARY PAVEMENT MARKING

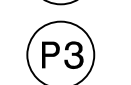
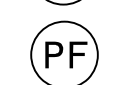
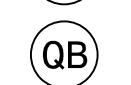
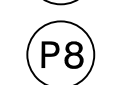
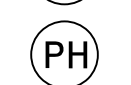
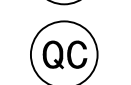
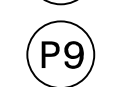
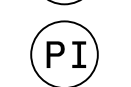
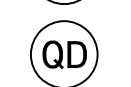
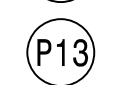
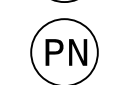
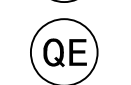
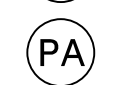
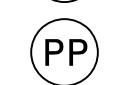
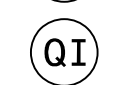
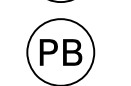
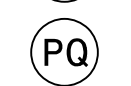
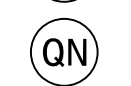
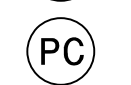
PAINT

 24" WHITE STOP BAR (PAINT)	 4" WHITE LANE LINE (PAINT)	 LEFT TURN ARROW (PAINT)
 24" WHITE CROSSWALK LINE (PAINT)	 4" 10' YELLOW SKIP (PAINT)	 RIGHT TURN ARROW (PAINT)
 4" WHITE 2'-6"/ SP MINI-SKIP (PAINT)	 4" YELLOW SINGLE CENTER (PAINT)	 STRAIGHT ARROW (PAINT)
 4" YELLOW 2'-6"/ SP MINI-SKIP (PAINT)	 4" YELLOW DOUBLE CENTER (PAINT)	 STRAIGHT-LEFT ARROW (PAINT)
 8" WHITE 3'-9"/ SP MINI-SKIP (PAINT)	 8" WHITE GORELINE (PAINT)	 STRAIGHT-RIGHT COMBO. (PAINT)
 4" WHITE EDGE LINE (PAINT)	 8" YELLOW DIAGONAL (PAINT)	 ALPHANUMERIC CHARACTER (PAINT)
 4" YELLOW EDGE LINE (PAINT)	 8" WHITE CROSSWALK LINE (PAINT)	 24" YIELD LINE TRIANGLE
 4" WHITE 10'-30"/ SP SKIP (PAINT)	 8" WHITE LANE LINE (PAINT)	
 4" WHITE 3'-9"/ SP MINI-SKIP (PAINT)		

COLD APPLIED PLASTIC, TYPE IV - REMOVABLE TAPE

 24" WHITE STOP BAR (TAPE)	 4" WHITE EDGE LINE (TAPE)	 4" YELLOW DOUBLE CENTER (TAPE)
---	---	--

PLOT DRIVER: NCD0T.pd\color_eng_50.ppt
 USER: erbrooks
 FILE: c:\pwworking\tpa\d0487729\U-3308-TMP-TMP-01.dgn
 PENTABLE: NCD0T_tcp.tbl
 DATE: 5/12/2016
 TIME: 3:56:55 PM

DOCUMENT NOT CONSIDERED FINAL
UNLESS ALL SIGNATURES COMPLETED

APPROVED  SEAL R. ERSKINE BROOKS ENGINEER 032584	DIVISION OF HIGHWAYS NORTH CAROLINA DEPARTMENT OF TRANSPORTATION WORK ZONE TRAFFIC CONTROL	ROADWAY STANDARD DRAWINGS & LEGEND
---	---	---------------------------------------

PROJECT NOTES

PROJ. REFERENCE NO.	SHEET NO.
U-3308	TMP-2
 HDR Engineering, Inc. of the Carolinas 3733 National Drive, Suite 207 Raleigh, N.C. 27612 N.C.B.E.L.S. License Number: F-0116	

MANAGEMENT STRATEGIES

THIS PROJECT WILL BE COMPLETED BY MAINTAINING TRAFFIC ON EXISTING NC 55 AND NC 147, EXCEPT AS NOTED IN THE PHASING FOR OVERHEAD BRIDGE WORK, DRAINAGE INSTALLATIONS, AND UTILITY WORK AS NECESSARY. RECONSTRUCTION OF NC 55/NC 147 RAMPS WILL BE COMPLETED BY USE OF FLAGGERS, CLOSURES AND DETOURS. ALL OTHER CONSTRUCTION AND Y-LINE WORK WILL BE COMPLETED AWAY FROM TRAFFIC DURING A CLOSURE OF EACH STREET. TIE-INS OF EACH Y-LINE TO NC 55 WILL BE COMPLETED BY USE OF FLAGGERS AND LANE CLOSURES ALONG NC 55. TEMPORARY PAVEMENT AND TRAFFIC SHIFTS WILL BE REQUIRED TO MAINTAIN TRAFFIC AND ALLOW ADEQUATE ROOM FOR CONSTRUCTION. TEMPORARY PAVEMENT AND TEMPORARY WEDGING WILL BE REQUIRED TO TRANSITION FROM EXISTING PAVEMENT TO THE PERMANENT PAVEMENT AND FOR TEMPORARY TIE-INS FROM EXISTING NC 55 TO Y-LINES WHERE THE PROPOSED GRADES DO NOT MATCH EXISTING NC 55.

PEDESTRIANS ACCESS WILL BE MAINTAINED ALONG EXISTING FACILITIES AND NEW SECTIONS OF PERMANENT SIDEWALK. WHEN REQUIRED DUE TO CLOSURES OF EXISTING SIDEWALK, PEDESTRIAN ACCESS WILL BE MAINTAINED BY USE OF PEDESTRIAN DETOURS ALONG ADJACENT STREETS.

THE REPLACEMENT OF THE NC 55 BRIDGE OVER NC 147 WILL BE COMPLETED BY USE OF TEMPORARY TRAFFIC PATTERNS ON NC 55 WHILE MAINTAINING TRAFFIC ON NC 55 AND NC 147. TEMPORARY CLOSURES OF NC 147 WILL BE REQUIRED TO COMPLETE OVERHEAD BRIDGE WORK.

WIDENING OF AND CONSTRUCTION ALONG RAMPS -R1- AND -R2- WILL BE COMPLETED UNDER TRAFFIC OR BY USE OF TEMPORARY RAMP CLOSURES. RECONSTRUCTION OF RAMPS -R3- AND -R5- WILL BE COMPLETED BY USE OF SHORT-TERM CLOSURES DURING THEIR RESPECTIVE PHASE. RAMP -R4- WILL BE CLOSED AND DETOURED LONG-TERM FOR THE DURATION OF PHASE 2.

CONSTRUCTION OF PHASE 1, STEPS 1-10, NORTH OF THE NC 147 INTERCHANGE, WILL BE COMPLETED BY MAINTAINING TRAFFIC IN THE EXISTING PATTERNS AND COMPLETING ALL TEMPORARY PAVEMENT, WIDENING, AND NEW LOCATION SECTIONS AWAY FROM TRAFFIC OR BY USE OF FLAGGERS AND LANE CLOSURES.

TRAFFIC WILL THEN BE SHIFTED TO AREAS OF TEMPORARY PAVEMENT ALONG NC 55 FROM MAIN STREET TO HOLLOWAY STREET TO ALLOW PERMANENT CONSTRUCTION TO CONTINUE IN PHASE 1, STEPS 11-21.

TRAFFIC WILL BE SHIFTED TO A TEMPORARY PATTERN ON AREAS OF NEW PAVEMENT ALONG NC 55 TO ALLOW PERMANENT CONSTRUCTION TO CONTINUE IN PHASE 2.

IN PHASE 3, TRAFFIC WILL BE SHIFTED TO THE FINAL PATTERN ON NC 55, SOUTH OF MAIN STREET. NORTH OF MAIN STREET TRAFFIC WILL BE PLACED IN A TEMPORARY PATTERN BY USE OF DRUMS. IN ORDER TO UTILIZE THE FINAL SIGNAL PATTERNS, TRAFFIC WILL BE PLACED IN THE FINAL PATTERN ON NC 55 AT EACH SIGNALIZED INTERSECTION NORTH OF MAIN STREET. USING LANE CLOSURES, ALL REMAINING MEDIAN WORK WILL BE COMPLETED, FOLLOWED BY REMAINING OUTSIDE CURB AND GUTTER AND SIDEWALK WORK.

GENERAL NOTES

CHANGES MAY BE REQUIRED WHEN PHYSICAL DIMENSIONS IN THE DETAIL DRAWINGS, STANDARD DETAILS, AND ROADWAY DETAILS ARE NOT ATTAINABLE TO MEET FIELD CONDITIONS OR RESULT IN DUPLICATE OR UNDESIRED OVERLAPPING OF DEVICES. MODIFICATION MAY INCLUDE: MOVING, SUPPLEMENTING, COVERING, OR REMOVAL OF DEVICES AS DIRECTED BY THE ENGINEER.

THE FOLLOWING GENERAL NOTES APPLY AT ALL TIMES FOR THE DURATION OF THE CONSTRUCTION PROJECT EXCEPT WHEN OTHERWISE NOTED IN THE PLAN OR DIRECTED BY THE ENGINEER.

TIME RESTRICTIONS

A) DO NOT CLOSE OR NARROW TRAVEL LANES AS FOLLOWS:

ROAD NAME	DAY AND TIME RESTRICTIONS
1) -YA-/DURHAM FREEWAY (NC 147) -R1-, -R2-, -R3-, -R4-, -R5-	MON-FRI: 6:00 A.M. TO 8:00 P.M. SAT & SUN: 10:00 A.M. TO 8:00 P.M.
2) -LALT-/ALSTON AVENUE (NC 55) -Y2/ANGIER AVENUE (SR 1926) -Y4- & -Y5-/MAIN STREET -Y18-/LIBERTY STREET -Y22-/HOLLOWAY STREET (US 70 BUS / NC 98)	MON-FRI: 7:00 A.M. TO 9:00 A.M. & 4:00 P.M. TO 7:00 P.M.

B) DO NOT CLOSE OR NARROW TRAVEL LANES DURING HOLIDAYS AND SPECIAL EVENTS AS FOLLOWS:

ROAD NAME

- LALT-/ALSTON AVENUE (NC 55)
- YA-/DURHAM FREEWAY (NC 147), AND RAMPS -R1-, -R2-, -R3-, -R4-, -R5-
- Y2-/ANGIER AVENUE (SR 1926)
- Y4- & -Y5-/MAIN STREET
- Y15-/TAYLOR STREET
- Y18-/LIBERTY STREET
- Y22-/HOLLOWAY STREET (US 70 BUS/NC 98)

HOLIDAY

1. FOR ANY UNEXPECTED OCCURRENCE THAT CREATES UNUSUALLY HIGH TRAFFIC VOLUMES, AS DIRECTED BY THE ENGINEER.
2. FOR NEW YEAR'S, BETWEEN THE HOURS OF 6:00 A.M. DECEMBER 31st TO 8:00 P.M. JANUARY 2ND. IF NEW YEAR'S DAY IS ON A FRIDAY, SATURDAY, SUNDAY, OR MONDAY THEN UNTIL 8:00 P.M. THE FOLLOWING TUESDAY.
3. FOR EASTER, BETWEEN THE HOURS OF 6:00 A.M. THURSDAY AND 8:00 P.M. MONDAY.
4. FOR MEMORIAL DAY, BETWEEN THE HOURS OF 6:00 A.M. FRIDAY TO 8:00 P.M. TUESDAY.
5. FOR INDEPENDENCE DAY, BETWEEN THE HOURS OF 6:00 A.M. THE DAY BEFORE INDEPENDENCE DAY AND 8:00 P.M. THE DAY AFTER INDEPENDENCE DAY.

IF INDEPENDENCE DAY IS ON A FRIDAY, SATURDAY, SUNDAY OR MONDAY THEN BETWEEN THE HOURS OF 6:00 A.M. THE THURSDAY BEFORE INDEPENDENCE DAY AND 8:00 P.M. THE TUESDAY AFTER INDEPENDENCE DAY.
6. FOR LABOR DAY, BETWEEN THE HOURS OF 6:00 A.M. FRIDAY AND 8:00 P.M. TUESDAY.
7. FOR THANKSGIVING DAY, BETWEEN THE HOURS OF 6:00 A.M. TUESDAY TO 8:00 P.M. MONDAY.
8. FOR CHRISTMAS, BETWEEN THE HOURS OF 6:00 A.M. THE FRIDAY BEFORE THE WEEK OF CHRISTMAS DAY AND 8:00 P.M. THE FOLLOWING TUESDAY AFTER THE WEEK OF CHRISTMAS.
9. FOR EVENTS OCCURRING AT THE FOLLOWING VENUES BETWEEN TWO (2) HOURS BEFORE THE START AND TWO (2) HOURS AFTER THE END.
 - DUKE UNIVERSITY - GRADUATION, FOOTBALL GAMES, MEN'S BASKETBALL GAMES, AND WOMEN'S BASKETBALL GAMES
 - DURHAM BULLS ATHLETIC PARK
 - DURHAM PERFORMING ARTS CENTER
 - NORTH CAROLINA CENTRAL UNIVERSITY - GRADUATION, FOOTBALL GAMES, MEN'S BASKETBALL GAMES, AND WOMEN'S BASKETBALL GAMES
 - DURHAM RESCUE MISSION (SEE LOCAL NOTE LN-03)
 - OTHER LARGE TRAFFIC VOLUME GENERATING EVENTS AS NOTED BY THE ENGINEER

C) DO NOT CLOSE ROADS AS FOLLOWS:

ROAD NAME	DAY AND TIME RESTRICTIONS
1) -LALT-/ALSTON AVENUE (NC 55) -YA-/DURHAM FWY (NC 147) -R1-, -R2-, -R3-, -R4-, -R5- -Y22-/HOLLOWAY STREET (US 70 BUS/NC 98)	MONDAY-SUNDAY: 6:00 A.M. TO 10:00 P.M.
2) -Y2-/ANGIER AVE (SR 1926) -Y4- & -Y5-/MAIN STREET -Y15- TAYLOR STREET -Y18- LIBERTY STREET	MONDAY-FRIDAY: 6:00 A.M. TO 10:00 P.M.

D) DO NOT STOP TRAFFIC AS FOLLOWS:

ROAD NAME	DAY AND TIME RESTRICTIONS	DURATION AND OPERATION
1) ALL ROADS	MONDAY-FRIDAY: 7:00 A.M. TO 9:00 A.M. 4:00 P.M. TO 7:00 P.M.	15 MINUTES FOR TRAFFIC SHIFTS

E) DO NOT CONDUCT MULTI-VEHICLE HAULING AS FOLLOWS; INGRESS AND EGRESS FROM RAMPS WILL BE ALLOWED:

ROAD NAME	DAY AND TIME RESTRICTIONS
-LALT-/ALSTON AVENUE (NC 55)	MONDAY-FRIDAY: 7:00 A.M. TO 9:00 A.M. &
-Y22-/HOLLOWAY STREET (US 70 BUS / NC 98)	4:00 P.M. TO 7:00 P.M.

F) DO NOT CONDUCT ANY HAULING OPERATIONS AGAINST THE FLOW OF TRAFFIC OF AN OPEN TRAVELWAY UNLESS THE HAULING OPERATION IS PROTECTED BY BARRIER OR GUARDRAIL OR AS DIRECTED BY THE ENGINEER.

LANE AND SHOULDER CLOSURE REQUIREMENTS

- G) REMOVE LANE CLOSURE DEVICES FROM THE LANE WHEN WORK IS NOT BEING PERFORMED BEHIND THE LANE CLOSURE OR WHEN A LANE CLOSURE IS NO LONGER NEEDED OR AS DIRECTED BY THE ENGINEER.
- H) WHEN PERSONNEL AND/OR EQUIPMENT ARE WORKING WITHIN 15 FT OF AN OPEN TRAVEL LANE, CLOSE THE NEAREST OPEN SHOULDER USING ROADWAY STANDARD DRAWING NO. 1101.04 UNLESS THE WORK AREA IS PROTECTED BY BARRIER OR GUARDRAIL OR A LANE CLOSURE IS INSTALLED.
- I) WHEN PERSONNEL AND/OR EQUIPMENT ARE WORKING ON THE SHOULDER ADJACENT TO AN UNDIVIDED FACILITY AND WITHIN 5 FT OF AN OPEN TRAVEL LANE, CLOSE THE NEAREST OPEN TRAVEL LANE USING ROADWAY STANDARD DRAWING NO. 1101.02 UNLESS THE WORK AREA IS PROTECTED BY BARRIER OR GUARDRAIL.

WHEN PERSONNEL AND/OR EQUIPMENT ARE WORKING ON THE SHOULDER ADJACENT TO A DIVIDED FACILITY AND WITHIN 10 FT OF AN OPEN TRAVEL LANE, CLOSE THE NEAREST OPEN TRAVEL LANE USING ROADWAY STANDARD DRAWING NO. 1101.02 UNLESS THE WORK AREA IS PROTECTED BY BARRIER OR GUARDRAIL.
- J) WHEN PERSONNEL AND/OR EQUIPMENT ARE WORKING WITHIN A LANE OF TRAVEL OF AN UNDIVIDED OR DIVIDED FACILITY, CLOSE THE LANE ACCORDING TO THE TRAFFIC CONTROL PLANS, ROADWAY STANDARD DRAWINGS, OR AS DIRECTED BY THE ENGINEER. CONDUCT THE WORK SO THAT ALL PERSONNEL AND/OR EQUIPMENT REMAIN WITHIN THE CLOSED TRAVEL LANE.
- K) DO NOT WORK SIMULTANEOUSLY WITHIN 15 FT ON BOTH SIDES OF AN OPEN TRAVELWAY, RAMP, OR LOOP WITHIN THE SAME LOCATION UNLESS PROTECTED WITH GUARDRAIL OR BARRIER.

PAVEMENT EDGE DROP OFF REQUIREMENTS

L) BACKFILL AT A 6:1 SLOPE UP TO THE EDGE AND ELEVATION OF EXISTING PAVEMENT IN AREAS ADJACENT TO AN OPENED TRAVEL LANE THAT HAS AN EDGE OF PAVEMENT DROP-OFF AS FOLLOWS:

BACKFILL DROP-OFFS THAT EXCEED 2 INCHES ON ROADWAYS WITH POSTED SPEED LIMITS OF 45 MPH OR GREATER.

BACKFILL DROP-OFFS THAT EXCEED 3 INCHES ON ROADWAYS WITH POSTED SPEED LIMITS LESS THAN 45 MPH.



BACKFILL WITH SUITABLE COMPACTED MATERIAL, AS APPROVED BY THE ENGINEER, AT NO EXPENSE TO THE DEPARTMENT.

M) DO NOT EXCEED A DIFFERENCE OF 2 INCHES IN ELEVATION BETWEEN OPEN LANES OF TRAFFIC FOR NOMINAL LIFTS OF 1.5 INCHES. INSTALL ADVANCE WARNING "UNEVEN LANES" SIGNS (W8-11) 500 FT. IN ADVANCE AND A MINIMUM OF EVERY HALF MILE THROUGHOUT THE UNEVEN AREA.

PLOT DRIVER: NCD07.pdf_color_eng_50.ppt
 USER: erbrooks
 FILE: c:\pwworking\paw\d0487729-U-3308-TMP-TMP-02.dgn
 PENTABLE: NCD07_tcp.tbl
 DATE: 5/12/2016
 TIME: 3:57:04 PM

REVISIONS

**DOCUMENT NOT CONSIDERED FINAL
UNLESS ALL SIGNATURES COMPLETED**

APPROVED  DATE: 5/13/2016 		PROJECT NOTES
---	---	---------------

PROJ. REFERENCE NO.	SHEET NO.
U-3308	TMP-2A
 HDR Engineering, Inc. of the Carolinas 3733 National Drive, Suite 207 Raleigh, N.C. 27612 N.C.B.E.L.S. License Number: F-0116	

PROJECT NOTES

GENERAL NOTES

TRAFFIC PATTERN ALTERATIONS

N) NOTIFY THE ENGINEER TWENTY ONE (21) CALENDAR DAYS PRIOR TO ANY TRAFFIC PATTERN ALTERATION.

SIGNING

- O) INSTALL ADVANCE WORK ZONE WARNING SIGNS WHEN WORK IS WITHIN 40 FT FROM THE EDGE OF TRAVEL LANE AND NO MORE THAN THREE (3) DAYS PRIOR TO THE BEGINNING OF CONSTRUCTION.
- P) PROVIDE SIGNING AND DEVICES REQUIRED TO CLOSE THE ROAD ACCORDING TO THE ROADWAY STANDARD DRAWINGS AND TRAFFIC CONTROL PLANS.

PROVIDE SIGNING REQUIRED FOR THE OFF-SITE DETOUR ROUTE AS SHOWN IN THE TRAFFIC CONTROL PLANS.

Q) COVER OR REMOVE ALL SIGNS AND DEVICES REQUIRED TO CLOSE THE ROAD WHEN ROAD CLOSURE IS NOT IN OPERATION.

COVER OR REMOVE ALL SIGNS REQUIRED FOR THE OFF-SITE DETOUR WHEN THE DETOUR IS NOT IN OPERATION.

R) ENSURE ALL NECESSARY SIGNING IS IN PLACE PRIOR TO ALTERING ANY TRAFFIC PATTERN.

S) INSTALL BLACK ON ORANGE "DIP" SIGNS (W8-2) AND/OR "BUMP" SIGNS (W8-1) 500 FT. IN ADVANCE OF THE UNEVEN AREA, OR AS DIRECTED BY THE ENGINEER.

TRAFFIC BARRIER

T) INSTALL TEMPORARY BARRIER ACCORDING TO THE TRANSPORTATION MANAGEMENT PLANS A MAXIMUM OF TWO (2) WEEKS PRIOR TO BEGINNING WORK IN ANY LOCATION. ONCE TEMPORARY BARRIER IS INSTALLED AT ANY LOCATION PROCEED IN A CONTINUOUS MANNER TO COMPLETE THE PROPOSED WORK IN THAT LOCATION UNLESS OTHERWISE STATED IN THE TRANSPORTATION MANAGEMENT PLANS OR AS DIRECTED BY THE ENGINEER.

DO NOT PLACE BARRIER DIRECTLY ON ANY SURFACE OTHER THAN ASPHALT OR CONCRETE.

ONCE TEMPORARY BARRIER IS INSTALLED AT ANY LOCATION AND NO WORK IS PERFORMED BEHIND THE TEMPORARY BARRIER FOR A PERIOD LONGER THAN TWO (2) MONTHS, REMOVE / RESET TEMPORARY BARRIER AT NO COST TO THE DEPARTMENT UNLESS OTHERWISE STATED IN THE TRANSPORTATION MANAGEMENT PLANS, TEMPORARY BARRIER IS PROTECTING A HAZARD, OR AS DIRECTED BY THE ENGINEER.

INSTALL TEMPORARY BARRIER WITH THE TRAFFIC FLOW BEGINNING WITH THE UPSTREAM SIDE OF TRAFFIC. REMOVE TEMPORARY BARRIER AGAINST THE TRAFFIC FLOW BEGINNING WITH THE DOWNSTREAM SIDE OF TRAFFIC.

INSTALL AND SPACE DRUMS NO GREATER THAN TWICE THE POSTED SPEED LIMIT (MPH) TO CLOSE OR KEEP THE SECTION OF THE ROADWAY CLOSED UNTIL THE TEMPORARY BARRIER CAN BE PLACED OR AFTER THE TEMPORARY BARRIER IS REMOVED.

U) PROTECT THE APPROACH END OF MOVABLE/PORTABLE CONCRETE BARRIER AT ALL TIMES DURING THE INSTALLATION AND REMOVAL OF THE BARRIER BY EITHER A TRUCK MOUNTED ATTENUATOR (MAXIMUM 72 HOURS) OR A TEMPORARY CRASH CUSHION.

PROTECT THE APPROACH END OF MOVABLE/PORTABLE CONCRETE BARRIER FROM ONCOMING TRAFFIC AT ALL TIMES BY A TEMPORARY CRASH CUSHION UNLESS THE APPROACH END OF MOVABLE/PORTABLE CONCRETE BARRIER IS OFFSET FROM ONCOMING TRAFFIC AS FOLLOWS OR AS SHOWN IN THE PLANS: (SEE ALSO 1101.05)

POSTED SPEED LIMIT	MINIMUM OFFSET
40 OR LESS	15 FT
45 - 50	20 FT
55	25 FT
60 MPH or HIGHER	30 FT

TRAFFIC CONTROL DEVICES

V) WHEN LANE CLOSURES ARE NOT IN EFFECT SPACE CHANNELIZING DEVICES IN WORK AREAS NO GREATER IN FEET THAN TWICE THE POSTED SPEED LIMIT (MPH) EXCEPT, 10 FT ON-CENTER IN RADII, AND 3 FT OFF THE EDGE OF AN OPEN TRAVELWAY. REFER TO STANDARD SPECIFICATIONS FOR ROADS AND STRUCTURES SECTIONS 1130 (DRUMS), 1135 (CONES) AND 1180 (SKINNY DRUMS) FOR ADDITIONAL REQUIREMENTS.

W) PLACE TYPE III BARRICADES, WITH "ROAD CLOSED" SIGN R11-2 ATTACHED, OF SUFFICIENT LENGTH TO CLOSE ENTIRE ROADWAY.

X) PLACE ADDITIONAL SETS OF THREE CHANNELIZING DEVICES (DRUMS/CONES/SKINNY DRUMS) PERPENDICULAR TO THE EDGE OF TRAVELWAY ON 500 FT CENTERS WHEN UNOPENED LANES ARE CLOSED TO TRAFFIC.

PAVEMENT MARKINGS AND MARKERS

Y) INSTALL TEMPORARY PAVEMENT MARKINGS AND TEMPORARY PAVEMENT MARKERS ON INTERIM LAYERS OF PAVEMENT AS FOLLOWS:

ROAD NAME	MARKING	MARKER
ALL ROADS	PAINT (ON ASPHALT) COLD APPLIED PLASTIC - TYPE IV (ON CONCRETE)	TEMPORARY RAISED

Z) PLACE ONE APPLICATION OF PAINT FOR TEMPORARY TRAFFIC PATTERNS. PLACE A SECOND APPLICATION OF PAINT SIX (6) MONTHS AFTER THE INITIAL APPLICATION AND EVERY SIX MONTHS AS DIRECTED BY THE ENGINEER.

AA) TIE PROPOSED PAVEMENT MARKING LINES TO EXISTING PAVEMENT MARKING LINES.

BB) REMOVE/REPLACE ANY CONFLICTING/DAMAGED PAVEMENT MARKINGS AND MARKERS BY THE END OF EACH DAY'S OPERATION.

CC) TRACE THE PROPOSED MONOLITHIC ISLAND LOCATIONS WITH PROPER COLOR PAVEMENT MARKINGS PRIOR TO INSTALLATION. PLACE DRUMS TO DELINEATE ANY PROPOSED MONOLITHIC ISLANDS BEFORE INSTALLATION.

MISCELLANEOUS

DD) LAW ENFORCEMENT SHALL BE USED TO MAINTAIN TRAFFIC THROUGH THE WORK AREA AND/OR INTERSECTIONS AS DIRECTED BY THE ENGINEER.

EE) IN THE EVENT A TIE-IN CANNOT BE MADE IN ONE DAY'S TIME, BRING THE TIE-IN AREA TO AN APPROPRIATE ROADWAY ELEVATION AS DETERMINED BY THE ENGINEER. PLACE BLACK ON ORANGE "LOOSE GRAVEL" SIGNS (W8-7) AND BLACK ON ORANGE "PAVEMENT ENDS" SIGNS (W8-3) 250 FT. AND 500 FT. RESPECTIVELY IN ADVANCE OF THE UNEVEN AREAS. USE DRUMS TO DELINEATE THE EDGE OF ROADWAY ALONG UNPAVED AREAS.

* TEMPORARY TIE-INS USING ABC STONE WILL NOT BE PERMITTED ON THE FOLLOWING ROADS:

- LALT-/ALSTON AVENUE (NC 55)
- YA-/DURHAM FREEWAY (NC 147)
- ALL RAMPS
- Y2-/ANGIER AVENUE (SR 1926)
- Y4- & -Y5-/MAIN STREET
- Y15-/TAYLOR STREET
- Y18-/LIBERTY STREET
- Y22-/HOLLOWAY STREET (US 70 BUS / NC 98)

FF) ALL WHEELCHAIR RAMP LOCATIONS SHALL BE DERIVED FROM STATIONING SHOWN ON PAVEMENT MARKING PLANS OR AS DIRECTED BY THE ENGINEER IN COORDINATION WITH THE SIGNING AND DELINEATION UNIT.

GG) CONTRACTOR SHALL MAINTAIN SIDEWALK ACCESS AT ALL TIMES AS STATED IN THE PHASING. CONTRACTOR SHALL BE RESPONSIBLE TO PROVIDE TEMPORARY SIDEWALKS (CONCRETE, ASPHALT, OR OTHER SUITABLE MATERIAL AS APPROVED BY THE ENGINEER) AT ALL LOCATIONS WHERE THE OPEN PEDESTRIAN TRAVELWAY HAS BEEN REMOVED FOR CONSTRUCTION OPERATIONS (UTILITIES, DRAINAGE, ETC.).

HH) ADJUST SIDEWALK CLOSURE AND PEDESTRIAN DETOUR SIGNING AS REQUIRED AND AS DIRECTED BY THE ENGINEER. RELOCATE SIGNING TO ADJACENT STREETS AS NECESSARY DUE TO SIDEWALK CLOSURES AND ACTIVE WORK AREAS THROUGH THE DURATION OF THE PROJECT. REMOVE PEDESTRIAN DETOUR SIGNING UPON COMPLETION AND REOPENING OF SIDEWALK.

II) CONTRACTOR SHALL COORDINATE WITH TRIANGLE TRANSIT AUTHORITY (TTA) AND DURHAM AREA TRANSIT AUTHORITY (DATA) PRIOR TO ANY STREET CLOSURES AND/OR WORK THAT WILL IMPACT EXISTING BUS ROUTES AND BUS STOPS. ANY STOPS OR ROUTES THAT WILL BE IMPACTED BY CONSTRUCTION ACTIVITIES MUST BE TEMPORARILY CLOSED OR RELOCTED PRIOR TO BEGINNING WORK IN THAT LOCATION.

JJ) EXISTING SCHOOL ZONE FLASHERS MUST BE MAINTAINED THROUGHOUT CONSTRUCTION. PER THE ENGINEER, RELOCATE FLASHERS AS NECESSARY TO ACCOMMODATE TRAFFIC SHIFTS DURING CONSTRUCTION.

KK) CONTRACTOR SHALL COORDINATE WITH ADJACENT NCDOT PROJECTS U-0071 AND I-3306A TO ENSURE CONFLICTING DETOUR ROUTES ARE NOT PROPOSED FOR CONCURRENT ACTIVITIES.

LL) CONTRACTOR SHALL COORDINATE WITH CITY OF DURHAM, AVONDALE ROAD SIDEWALK PROJECT TO ENSURE U-3308 DEOUR ROUTES AND SIGNING DO NOT CONFLICT WITH THE WORK ZONE ACTIVITIES FOR THE SIDEWALK PROJECT.

LOCAL NOTES

LN-01) WHEN REMOVING EXISTING BRIDGE AND HANGING PROPOSED GIRDERS ON -LALT- BRIDGE, AT NIGHT CLOSE -YA- (NC 147) USING RSD 1101.03, SHEET 7 OF 9, AND CLOSE -LALT- (NC 55) USING RSD 1101.03, SHEET 1 OF 9. USE LAW ENFORCEMENT AND/OR DETOUR SIGNING, AS DIRECTED BY THE ENGINEER TO MAINTAIN NC 55 AND NC 147 TRAFFIC ALONG THE DETOUR ROUTES. (SEE SHEET TMP-2AV FOR DETOUR ROUTES).

* NOTE - ROAD CLOSURES FOR THIS WORK MAY NOT BE IMPLEMENTED CONCURRENTLY WITH THE ROAD CLOSURES FOR -Y- AND RAIL BRIDGE WORK OVER -LALT-, AS NOTED IN LOCAL NOTE LN-02, OR DURING THE CLOSURE OF RAMPS -R1-, -R2-, -R3, OR -R5-.

LN-02) WHEN REMOVING EXISTING BRIDGES AND HANGING PROPOSED GIRDERS ON -Y- (PETTIGREW STREET) BRIDGE, NORFOLK SOUTHERN RAILROAD BRIDGE, AND CSX RAILROAD BRIDGE, CLOSE -LALT- (NC 55) AT NIGHT USING RSD 1101.03, SHEET 1 OF 9. USE LAW ENFORCEMENT AND/OR DETOUR SIGNING, AS DIRECTED BY THE ENGINEER TO MAINTAIN NC 55 TRAFFIC ALONG THE DETOUR ROUTES. (SEE SHEET TMP-2D FOR DETOUR ROUTE)

* NOTE - ROAD CLOSURES FOR THIS WORK MAY NOT BE IMPLEMENTED CONCURRENTLY WITH THE ROAD CLOSURES FOR -LALT- BRIDGE WORK OVER -YA-, AS NOTED IN LOCAL NOTE LN-01.

LN-03) COORDINATE WITH DURHAM RESCUE MISSION FOR ALL WORK ON NC 55 (ALSTON AVENUE), MAIN STREET, AND MORNING GLORY AVENUE. DURING THE TIME OF COMMUNITY EVENTS ORGANIZED AND CONDUCTED BY THE MISSION, DO NOT CLOSE ROADS OR TRAVEL LANES ADJACENT TO DURHAM RESCUE MISSION IN A MANNER THAT WOULD DISRUPT THE SETUP AND OPERATIONS OF EACH EVENT.

- * YEARLY COMMUNITY EVENTS CONDUCTED BY THE MISSION INCLUDE:
 - BACK TO SCHOOL (AUGUST)
 - EASTER
 - THANKSGIVING
 - CHRISTMAS

LN-04) WORK ADJACENT TO EASTWAY ELEMENTARY SCHOOL ON -Y15 (TAYLOR STREET) AND -Y17- (HOPKINS STREET) SHALL BE CONDUCTED WHILE THE SCHOOL IS NOT IN SESSION SO AS TO NOT DISRUPT DAILY SCHOOL ACTIVITIES. REFER TO THE DURHAM PUBLIC SCHOOL CALENDAR FOR YEARLY SCHEDULES. PROVIDE ADVANCE NOTIFICATION TO THE SCHOOL OF ALL ROAD CLOSURES.

LN-05) PROVIDE INGRESS AND EGRESS TO LOS PRIMOS SUPERMARKET VIA -Y6- (MORNING GLORY AVENUE) TO NC 55 (ALSTON AVENUE) AT ALL TIMES FOR DELIVERY TRUCK ACCESS. PROVIDE TEMPORARY ACCESS BY USE OF ABC OR ASPHALT BASE COURSE. COORDINATE WITH LOS PRIMOS TO ALLOW DELIVERY TRUCKS THROUGH THE WORK AREA FOR ACCESS TO/FROM THE SUPERMARKET.

LN-06) PROVIDE INGRESS AND EGRESS TO SAV-A-LOT GROCERY STORE VIA -Y16- (HOPKINS STREET) TO NC 55 (ALSTON AVENUE) AT ALL TIMES FOR DELIVERY TRUCK ACCESS. PROVIDE TEMPORARY ACCESS BY USE OF ABC OR ASPHALT BASE COURSE. COORDINATE WITH SAV-A-LOT TO ALLOW DELIVERY TRUCKS THROUGH THE WORK AREA FOR ACCESS TO/FROM THE GROCERY STORE.

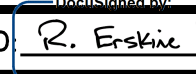
APPROVED  DATE: 5/13/2016

SEAL



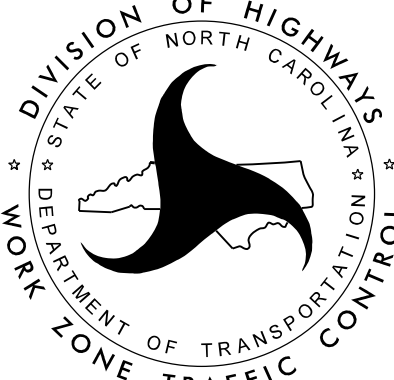

WORK ZONE TRAFFIC CONTROL

PROJECT NOTES

DOCUMENT NOT CONSIDERED FINAL UNLESS ALL SIGNATURES COMPLETED

PLOT DRIVER: NCDOT_pdf_color_eng_50.ppt
 USER: erbrooks
 FILE: c:\pwworking\paw\d0487729\U-3308_TMP_TMP_02.dgn
 PENTABLE: NCDOT_tcp.tbl
 DATE: 5/12/2016
 TIME: 3:57:04 PM

REVISIONS

NOTES FOR TEMPORARY SHORING No. 1

FOR TEMPORARY SHORING, AND POSITIVE PROTECTION FOR TEMPORARY SHORING, SEE PLANS AND TEMPORARY SHORING PROJECT SPECIAL PROVISION.

BEFORE BEGINNING TEMPORARY SHORING DESIGN OR CONSTRUCTION, SURVEY EXISTING GROUND ELEVATIONS IN THE VICINITY OF SHORING LOCATIONS TO DETERMINE ACTUAL SHORING HEIGHTS.

DESIGN TEMPORARY SHORING FROM STATION -LALT- 15+25 ±, 7.5 FT LEFT TO STATION -LALT- 15+57 ±, 7.5 FT LEFT FOR THE FOLLOWING ASSUMED SOIL PARAMETERS AND GROUNDWATER ELEVATION:

- UNIT WEIGHT (γ) = 120 LB/CF
- FRICTION ANGLE (ϕ) = 24 DEGREES (RESIDUAL SOIL)
- FRICTION ANGLE (ϕ) = 30 DEGREES (EMBANKMENT SOIL)
- FRICTION ANGLE (ϕ) = 36 DEGREES (WEATHERED ROCK)
- COHESION (c) = 0 LB/SF
- GROUNDWATER ELEVATION = 376.5 FT ±

DRIVEN PILING FOR TEMPORARY SHORING FROM STATION -LALT- 15+25 ±, 7.5 FT LEFT TO STATION -LALT- 15+57 ±, 7.5 FT LEFT MAY NOT PENETRATE BELOW ELEVATION 365.8 FT DUE TO OBSTRUCTIONS, VERY DENSE OR HARD SOIL, BOULDERS OR WEATHERED OR HARD ROCK.

DO NOT USE A TEMPORARY WALL FOR TEMPORARY SHORING FROM STATION -LALT- 15+25 ±, 7.5 FT LEFT, TO STATION -LALT- 15+57 ±, 7.5 FT LEFT.

TEMPORARY SHORING FROM STATION -LALT- 15+25 ±, 7.5 FT LEFT, TO STATION -LALT- 15+57 ±, 7.5 FT LEFT, WILL BE REQUIRED TO REMAIN IN PLACE AND CUT OFF BELOW THE PAVEMENT STRUCTURE. USE PRECAST CONCRETE OR STEEL PLATE LAGGING FOR TEMPORARY SHORING.

NOTES FOR TEMPORARY SHORING No. 3

FOR TEMPORARY SHORING AND POSITIVE PROTECTION FOR TEMPORARY SHORING, SEE PLANS AND TEMPORARY SHORING PROJECT SPECIAL PROVISION.

BEFORE BEGINNING TEMPORARY SHORING DESIGN OR CONSTRUCTION, SURVEY EXISTING GROUND ELEVATIONS IN THE VICINITY OF SHORING LOCATIONS TO DETERMINE ACTUAL SHORING HEIGHTS.

DESIGN TEMPORARY SHORING FROM STATION -LALT- 59+80 ±, 6.0-9.0 FT LEFT, TO STATION -LALT- 61+75 ±, 6.0-9.0 FT LEFT FOR THE FOLLOWING ASSUMED SOIL PARAMETERS AND GROUNDWATER ELEVATION:

- UNIT WEIGHT (γ) = 120 LB/CF
- FRICTION ANGLE (ϕ) = 24 DEGREES (RESIDUAL SOIL)
- FRICTION ANGLE (ϕ) = 30 DEGREES (EMBANKMENT SOIL)
- FRICTION ANGLE (ϕ) = 36 DEGREES (WEATHERED ROCK)
- COHESION (c) = 0 LB/SF
- GROUNDWATER ELEVATION = 348.0 FT ±

DRIVEN PILING FOR TEMPORARY SHORING FROM STATION -LALT- 59+80 ±, 6.0-9.0 FT LEFT, TO STATION -LALT- 61+75 ±, 6.0-9.0 FT LEFT, MAY NOT PENETRATE BELOW ELEVATION 347.5 FT DUE TO OBSTRUCTIONS, VERY DENSE OR HARD SOIL, BOULDERS OR WEATHERED OR HARD ROCK.

DO NOT USE A TEMPORARY WALL FOR TEMPORARY SHORING STATION -LALT- 59+80 ±, 6.0-9.0 FT LEFT, TO STATION -LALT- 61+75 ±, 6.0-9.0 FT LEFT.

THE TEMPORARY SHORING NOTES SHOWN ON THIS SHEET WERE PROVIDED THROUGH SEALED DOCUMENTS FROM THE GEOTECHNICAL ENGINEERING UNIT. THE FIRST DOCUMENT WAS SUBMITTED TO THE WZTC SECTION ON 07/11/2014 AND SEALED BY A PROFESSIONAL ENGINEER, JINYOUNG PARK, LICENSE # 032171. THE SECOND DOCUMENT WAS SUBMITTED TO THE WZTC SECTION ON 10/08/2014 AND SEALED BY A PROFESSIONAL ENGINEER, THEIN ZAN, LICENSE # 30943.

NOTES FOR TEMPORARY SHORING No. 2

FOR TEMPORARY SHORING AND POSITIVE PROTECTION FOR TEMPORARY SHORING, SEE PLANS AND TEMPORARY SHORING PROJECT SPECIAL PROVISION.

BEFORE BEGINNING TEMPORARY SHORING DESIGN OR CONSTRUCTION, SURVEY EXISTING GROUND ELEVATIONS IN THE VICINITY OF SHORING LOCATIONS TO DETERMINE ACTUAL SHORING HEIGHTS.

DESIGN TEMPORARY SHORING FROM STATION -LALT- 17+36 ±, 7.5 FT LEFT TO STATION -LALT- 17+70 ±, 7.5 FT LEFT FOR THE FOLLOWING ASSUMED SOIL PARAMETERS AND GROUNDWATER ELEVATION:

- UNIT WEIGHT (γ) = 120 LB/CF
- FRICTION ANGLE (ϕ) = 24 DEGREES (RESIDUAL SOIL)
- FRICTION ANGLE (ϕ) = 30 DEGREES (EMBANKMENT SOIL)
- FRICTION ANGLE (ϕ) = 36 DEGREES (WEATHERED ROCK)
- COHESION (c) = 0 LB/SF
- GROUNDWATER ELEVATION = 376.5 FT ±

DRIVEN PILING FOR TEMPORARY SHORING FROM STATION -LALT- 17+36 ±, 7.5 FT LEFT, TO STATION -LALT- 17+70 ±, 7.5 FT LEFT, MAY NOT PENETRATE BELOW ELEVATION 365.8 FT DUE TO OBSTRUCTIONS, VERY DENSE OR HARD SOIL, BOULDERS OR WEATHERED OR HARD ROCK.

DO NOT USE A TEMPORARY WALL FOR TEMPORARY SHORING FROM STATION -LALT- 17+36 ±, 7.5 FT LEFT, TO STATION -LALT- 17+70 ±, 7.5 FT LEFT.

TEMPORARY SHORING FROM STATION -LALT- 17+36 ±, 7.5 FT LEFT, TO STATION -LALT- 17+70 ±, 7.5 FT LEFT, WILL BE REQUIRED TO REMAIN IN PLACE AND CUT OFF BELOW THE PAVEMENT STRUCTURE. USE PRECAST CONCRETE OR STEEL PLATE LAGGING FOR TEMPORARY SHORING.

NOTES FOR TEMPORARY SHORING No. 4

FOR TEMPORARY SHORING AND POSITIVE PROTECTION FOR TEMPORARY SHORING, SEE PLANS AND TEMPORARY SHORING PROJECT SPECIAL PROVISION.

BEFORE BEGINNING TEMPORARY SHORING DESIGN OR CONSTRUCTION, SURVEY EXISTING GROUND ELEVATIONS IN THE VICINITY OF SHORING LOCATIONS TO DETERMINE ACTUAL SHORING HEIGHTS.

DESIGN TEMPORARY SHORING FROM STATION -LALT- 36+30 ±, 7.9 FT RIGHT TO STATION -LALT- 38+25 ±, 6.6 FT RIGHT FOR THE FOLLOWING ASSUMED SOIL PARAMETERS AND GROUNDWATER ELEVATION:



- UNIT WEIGHT (γ) = 120 LB/CF
- FRICTION ANGLE (ϕ) = 24 DEGREES (RESIDUAL SOIL)
- FRICTION ANGLE (ϕ) = 30 DEGREES (EMBANKMENT SOIL)
- FRICTION ANGLE (ϕ) = 36 DEGREES (WEATHERED ROCK)
- COHESION (c) = 0 LB/SF
- GROUNDWATER ELEVATION = 349.0 FT ±

DRIVEN PILING FOR TEMPORARY SHORING FROM STATION -LALT- 36+30 ±, 7.9 FT RIGHT, TO STATION -LALT- 38+25 ±, 6.6 FT RIGHT, MAY NOT PENETRATE BELOW ELEVATION 356.0 FT DUE TO OBSTRUCTIONS, VERY DENSE OR HARD SOIL, BOULDERS OR WEATHERED OR HARD ROCK.

DO NOT USE A TEMPORARY WALL FOR TEMPORARY SHORING FROM STATION -LALT- 36+30 ±, 7.9 FT RIGHT, TO STATION -LALT- 38+25 ±, 6.6 FT RIGHT.

SHORING NO. 1 - 3

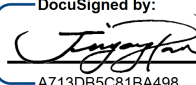
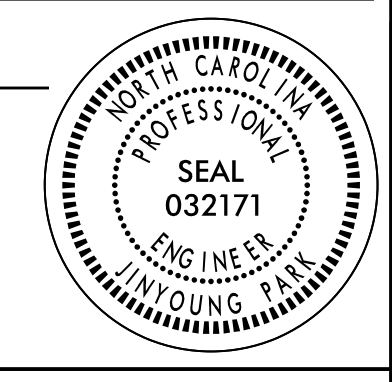
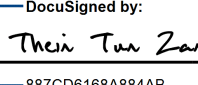
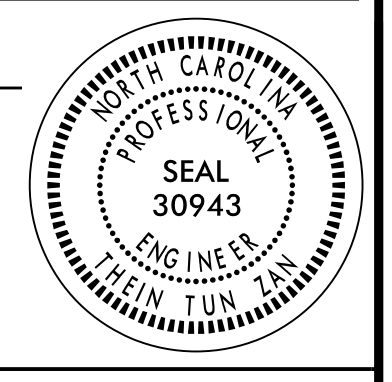
SHORING NO. 4

<p>APPROVED:  A713DB5C81B4498</p> <p>DATE: 5/12/2016</p> <p style="text-align: center;">SEAL</p> 	<p>APPROVED:  887CD8168A8A4B</p> <p>DATE: 5/12/2016</p> <p style="text-align: center;">SEAL</p> 		
<p>DOCUMENT NOT CONSIDERED FINAL UNLESS ALL SIGNATURES COMPLETED</p>	<p>DOCUMENT NOT CONSIDERED FINAL UNLESS ALL SIGNATURES COMPLETED</p>		

5/12/2016 9:41:13 AM C:\pwworking\tpa\d0487729\U-3308_TMP-02B.dgn

<p>1</p> <p>TYPE III BARRICADE(S)</p>	<p>2</p> <p>TYPE III BARRICADE</p>	<p>3</p> <p>TYPE III BARRICADE</p>			
<p>4</p> <p>TYPE III BARRICADE</p>	<p>5</p> <p>TYPE III BARRICADE</p>	<p>6</p> <p>TYPE III BARRICADE</p>	<p>7</p> <p>TYPE III BARRICADE</p>		
<p>8</p> <p>TYPE III BARRICADE</p>	<p>9</p> <p>TYPE III BARRICADE</p>	<p>10</p> <p>TYPE III BARRICADE</p>	<p>11</p> <p>TYPE III BARRICADE</p>		
<p>12</p> <p>TYPE III BARRICADE</p>	<p>13</p> <p>SP-200 36" X 36"</p>	<p>14</p> <p>R9-11 24" X 12"</p>	<p>15</p> <p>R9-11 24" X 12"</p>	<p>16</p> <p>M4-9B 30" X 24"</p>	<p>17</p> <p>M4-9B 30" X 24"</p>
<p>P1</p>	<p>P2</p>	<p>P3</p>	<p>P4</p>	<p>P5</p>	

SEE TMP-2AP THRU TMP-2AT FOR FOR SPECIAL SIGN DESIGN DETAILS

DOCUMENT NOT CONSIDERED FINAL UNLESS ALL SIGNATURES COMPLETED

APPROVED DATE: 5/13/2016

SEAL

DIVISION OF HIGHWAYS
STATE OF NORTH CAROLINA
DEPARTMENT OF TRANSPORTATION
WORK ZONE TRAFFIC CONTROL

ROAD CLOSURE BARRICADE,
PEDESTRIAN BARRICADE
AND SIGNING LEGEND

REVISIONS

PLOT DRIVER: NCDOT_pdf_color_eng_50.ppt PENTABLE: NCDOT_tcp.tbl
USER: erbrooks DATE: 5/12/2016 TIME: 3:57:19 PM
FILE: c:\pwworking\tpa\d0487729\U-3308_TMP-02C thru 02AB.dgn

REVISIONS

PLOT DRIVER: NCDOT_pdf_color_eng_50.ppt
 USER: erbrooks
 DATE: 5/13/2016
 TIME: 10:40:14 AM
 FILE: c:\pwworking\tpa\d048729\U-3308_TMP_02C.thru 02AB.dgn

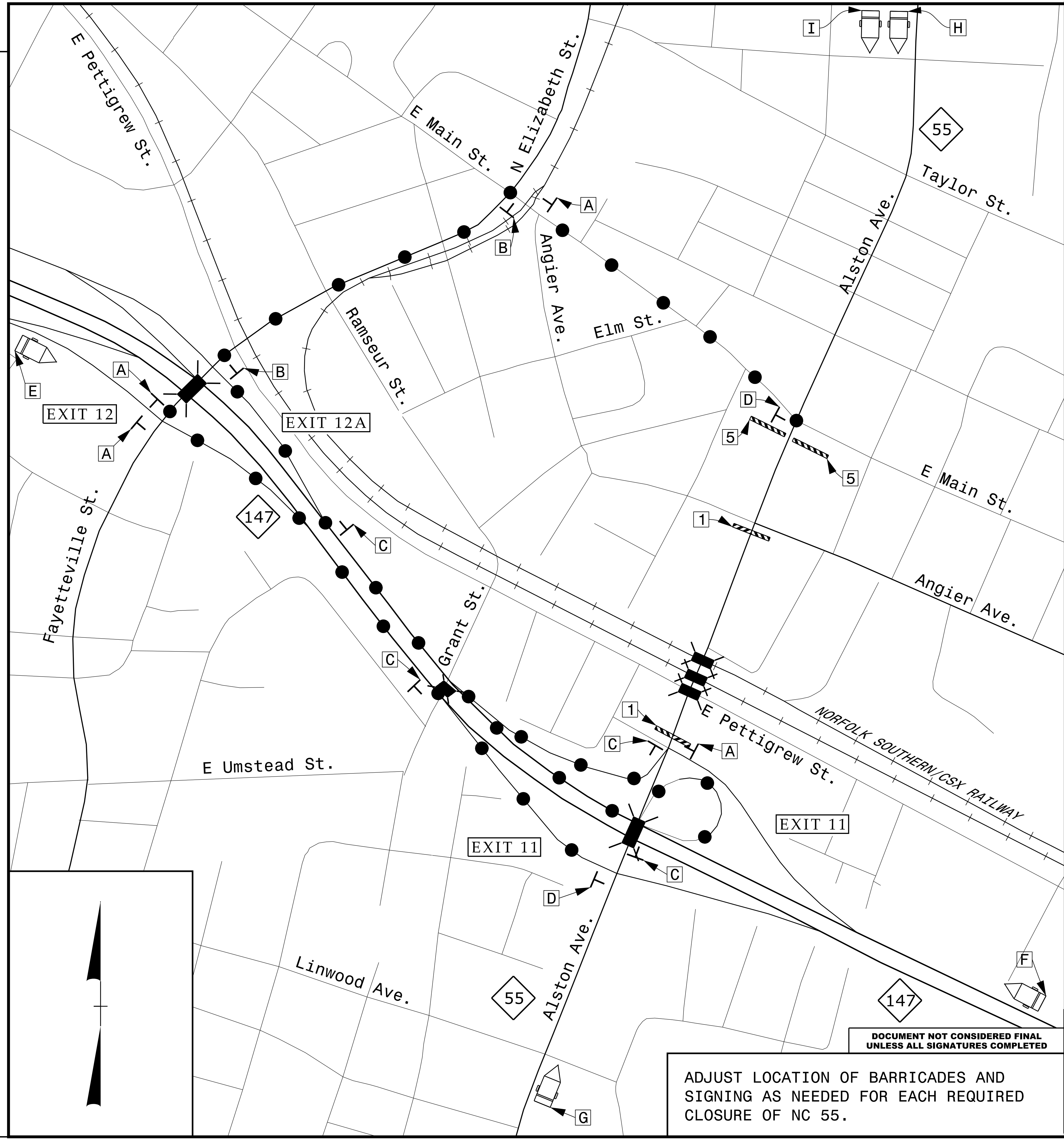

**DOCUMENT NOT CONSIDERED FINAL
 UNLESS ALL SIGNATURES COMPLETED**

ADJUST LOCATION OF BARRICADES AND
 SIGNING AS NEEDED FOR EACH REQUIRED
 CLOSURE OF NC 55.

PROJ. REFERENCE NO. U-3308	SHEET NO. TMP-2D
-------------------------------	---------------------

HDR HDR Engineering, Inc. of the Carolinas
 3733 National Drive, Suite 207 Raleigh, N.C. 27612
 N.C.B.E.L.S. License Number: F-0116

●●●●● DETOUR ROUTE

SEE SHEET TMP-2C FOR BARRICADE LEGEND
 SEE SHEET TMP-2AC FOR SPECIAL SIGN DESIGN DETAILS

A 	B 	C
--------------	--------------	--------------

D

E

MESSAGE NO. 1 NC 55 N CLOSED	MESSAGE NO. 2 USE EXIT 12
------------------------------------	---------------------------------

CHANGEABLE MESSAGE SIGN
 PLACE CMS 1 MILE MIN.
 IN ADVANCE OF EXIT 12

F

MESSAGE NO. 1 NC 55 N CLOSED	MESSAGE NO. 2 FOLLOW DETOUR EXIT 12A
------------------------------------	---

CHANGEABLE MESSAGE SIGN
 PLACE CMS 1 MILE MIN.
 IN ADVANCE OF EXIT 11

G

MESSAGE NO. 1 ALSTON CLOSED AHEAD	MESSAGE NO. 2 FOLLOW DETOUR
--	-----------------------------------

CHANGEABLE MESSAGE SIGN

H

MESSAGE NO. 1 NC 55 S CLOSED	MESSAGE NO. 2 MAIN ST TO GANN ST
------------------------------------	---

CHANGEABLE MESSAGE SIGN
 PLACE CMS ON AVONDALE DRIVE IN ADVANCE
 OF NC 55 INTERSECTION (EACH DIRECTION)

I

MESSAGE NO. 1 NC 55 S CLOSED	MESSAGE NO. 2 TRUCKS USE ALT ROUTE
------------------------------------	---

CHANGEABLE MESSAGE SIGN
 PLACE CMS ON AVONDALE DRIVE IN ADVANCE
 OF NC 55 INTERSECTION (EACH DIRECTION)

APPROVED: *R. Erskine Brooks* DATE: 5/13/2016

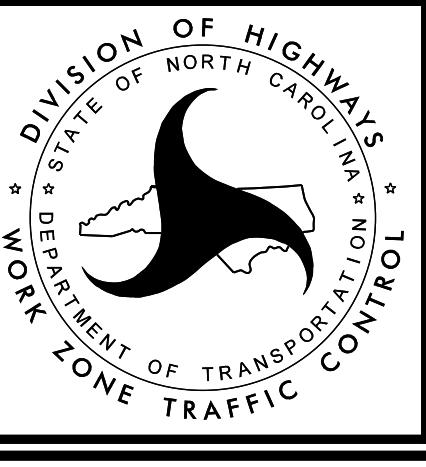

ALSTON AVENUE (NC 55)
 DETOUR ROUTE

MESSAGE NO. 1	MESSAGE NO. 2
NC 147 S RAMP CLOSED	FOLLOW DETOUR
CHANGEABLE MESSAGE SIGN	

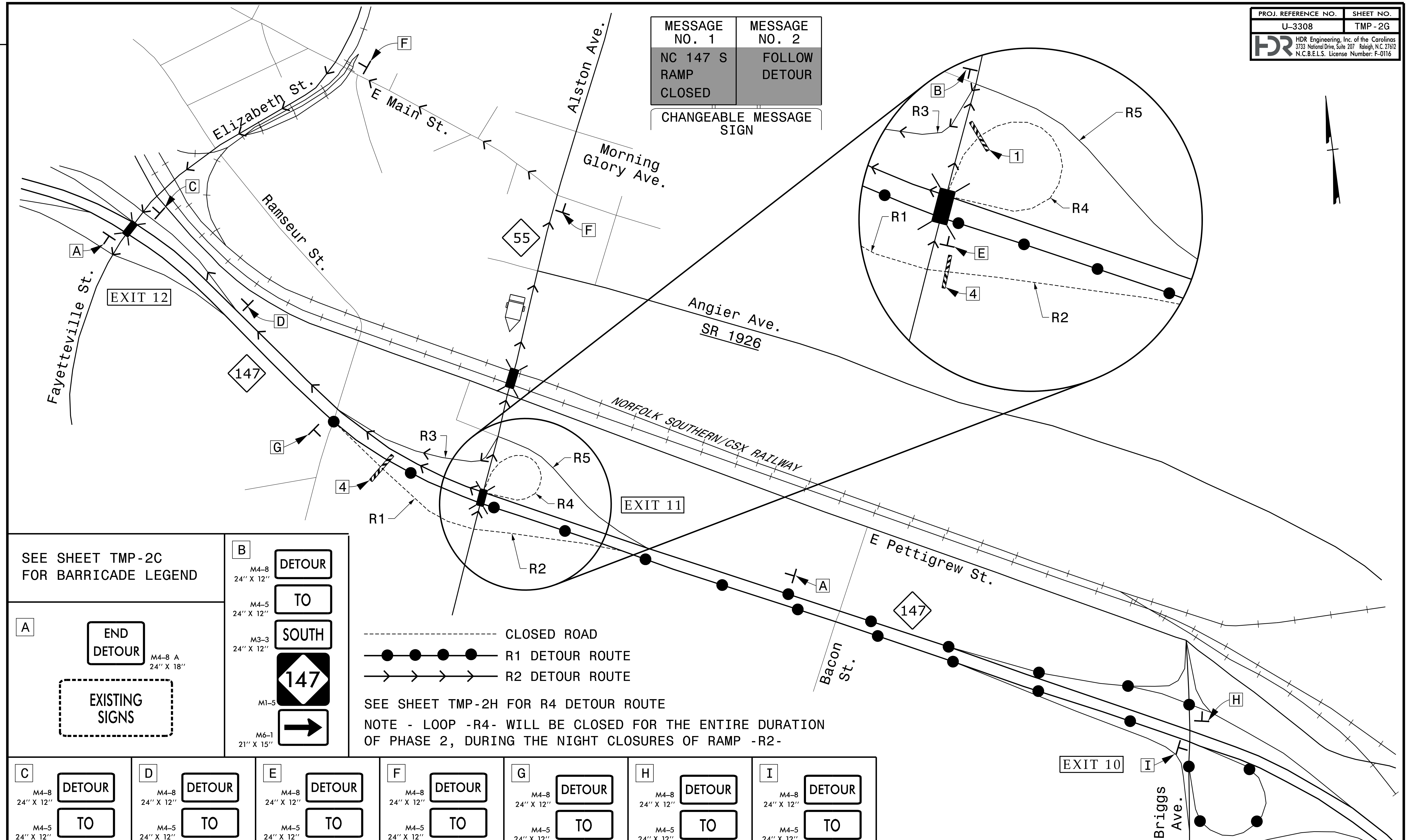

SEE SHEET TMP-2C FOR BARRICADE LEGEND

A END DETOUR (M4-8 A 24" X 18")

EXISTING SIGNS

B DETOUR TO SOUTH 147 (M4-8 24" X 12", M4-5 24" X 12", M3-3 24" X 12", M1-5 21" X 15", M6-1 21" X 15")

--- CLOSED ROAD

●●●● R1 DETOUR ROUTE

→→→→ R2 DETOUR ROUTE

SEE SHEET TMP-2H FOR R4 DETOUR ROUTE

NOTE - LOOP -R4- WILL BE CLOSED FOR THE ENTIRE DURATION OF PHASE 2, DURING THE NIGHT CLOSURES OF RAMP -R2-

C DETOUR TO SOUTH 147 (M4-8 24" X 12", M4-5 24" X 12", M3-3 24" X 12", M1-5 21" X 15", M6-1 L 21" X 15")

D DETOUR TO SOUTH 147 (M4-8 24" X 12", M4-5 24" X 12", M3-3 24" X 12", M1-5 21" X 15", M6-2 21" X 15")

E DETOUR TO 147 (M4-8 24" X 12", M4-5 24" X 12", M1-5 21" X 15", M6-3 21" X 15")

F DETOUR TO 147 (M4-8 24" X 12", M4-5 24" X 12", M1-5 21" X 15", M6-1 L 21" X 15")

G DETOUR TO 55 (M4-8 24" X 12", M4-5 24" X 12", M1-5 21" X 15", M6-3 21" X 15")

H DETOUR TO 55 (M4-8 24" X 12", M4-5 24" X 12", M1-5 21" X 15", M6-1 L 21" X 15")

I DETOUR TO 55 (M4-8 24" X 12", M4-5 24" X 12", M1-5 21" X 15", M6-2 21" X 15")

DOCUMENT NOT CONSIDERED FINAL UNLESS ALL SIGNATURES COMPLETED

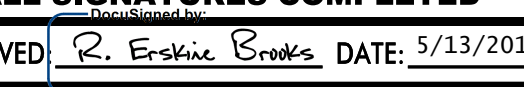
APPROVED:  DATE: 5/13/2016

SEAL: NORTH CAROLINA PROFESSIONAL ENGINEER 032584 P. ERSKINE BROOKS

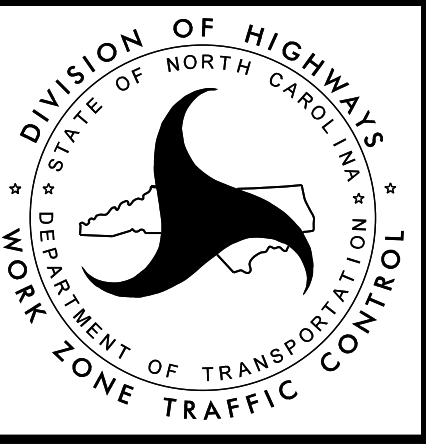







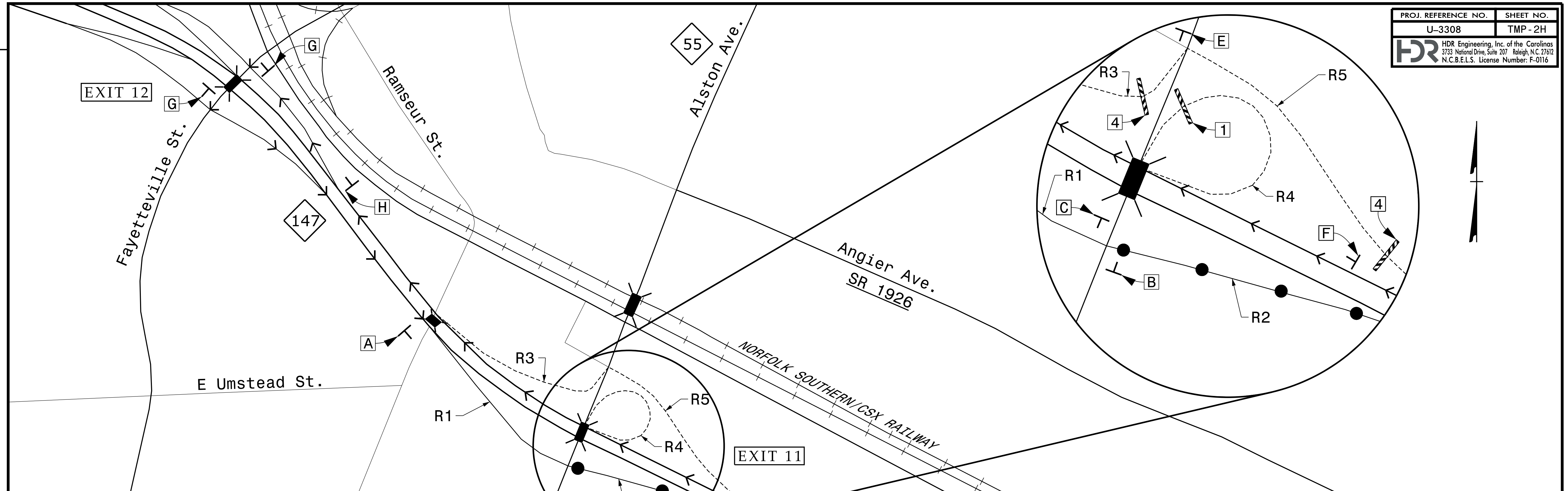





























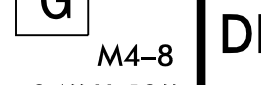

ALSTON AVENUE (NC 55) INTERCHANGE RAMP CLOSURES DETOUR ROUTE

PLOT DRIVER: NCDOT_pdf_color_eng_50.ppt
 USER: erbrooks
 DATE: 5/13/2016
 TIME: 10:40:19 AM
 FILE: c:\pwworking\tpa\048729\U-3308_TMP-TMP-02C thru 02AB.dgn

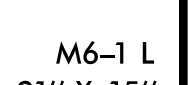
REVISIONS

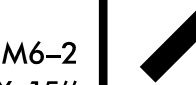

REVISIONS

SEE SHEET TMP-2C FOR BARRICADE LEGEND		A  M4-8 A 24" X 18" 	
B M4-8 24" X 12"  M4-5 24" X 12"  M3-1 24" X 12"   M1-5  M6-1 21" X 15" 	C M4-8 24" X 12"  M4-5 24" X 12"  M3-1 24" X 12"   M1-5  M6-1 L 21" X 15" 	D M4-8 24" X 12"  M4-5 24" X 12"  M3-1 24" X 12"   M1-5  M6-2 21" X 15" 	E M4-8 24" X 12"  M4-5 24" X 12"  M3-1 24" X 12"   M1-5  M6-3 21" X 15" 
F M4-8 24" X 12"  M4-5 24" X 12"   M1-5  M6-3 21" X 15" 	G M4-8 24" X 12"  M4-5 24" X 12"   M1-5  M6-1 L 21" X 15" 	H M4-8 24" X 12"  M4-5 24" X 12"   M1-5  M6-2 21" X 15" 	

MESSAGE NO. 1	MESSAGE NO. 2
NC 147 N LOOP CLOSED	FOLLOW DETOUR

CHANGEABLE MESSAGE SIGN

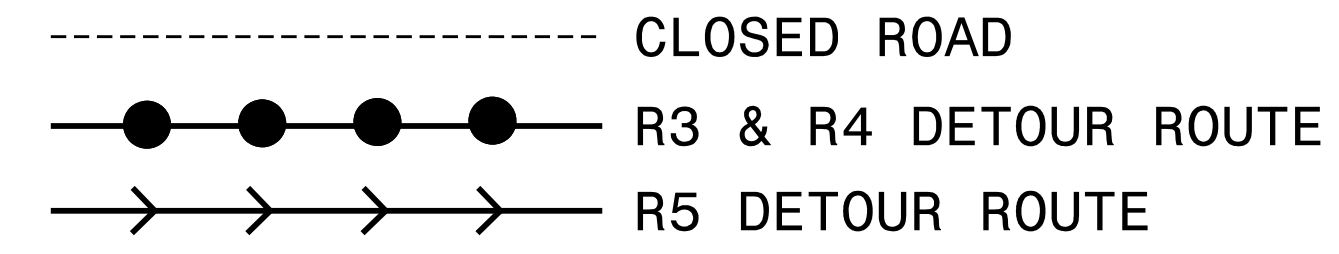

SEE SHEET TMP-2G FOR R2 DETOUR ROUTE
 NOTE - RAMP -R2- WILL INCUR PERIODIC NIGHT CLOSURES DURING PHASE 2. ADJUST CMS AND COVER SIGNING FOR -R4- CLOSURE AS NECESSARY DURING RAMP -R2- CLOSURES.

DOCUMENT NOT CONSIDERED FINAL
 UNLESS ALL SIGNATURES COMPLETED

APPROVED  DATE: 5/13/2016

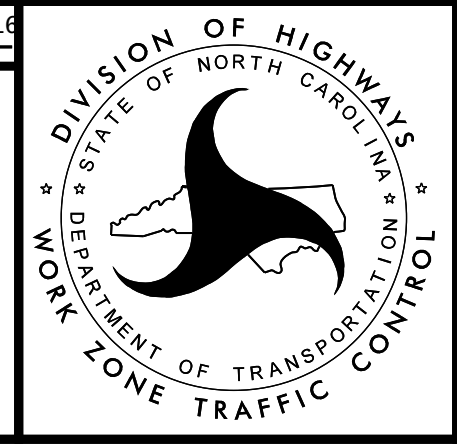

ALSTON AVENUE (NC 55)
 INTERCHANGE RAMP CLOSURES
 DETOUR ROUTE

PLOT DRIVER: NCDOT_pdf_color_eng_50.ppt
 USER: erbrooks
 PENTABLE: NCDOT_tcp.tbl
 DATE: 5/13/2016
 TIME: 10:40:21 AM
 FILE: c:\pwworking\paw\048729\U-3308_TMP_TMP-02C thru 02AB.dgn

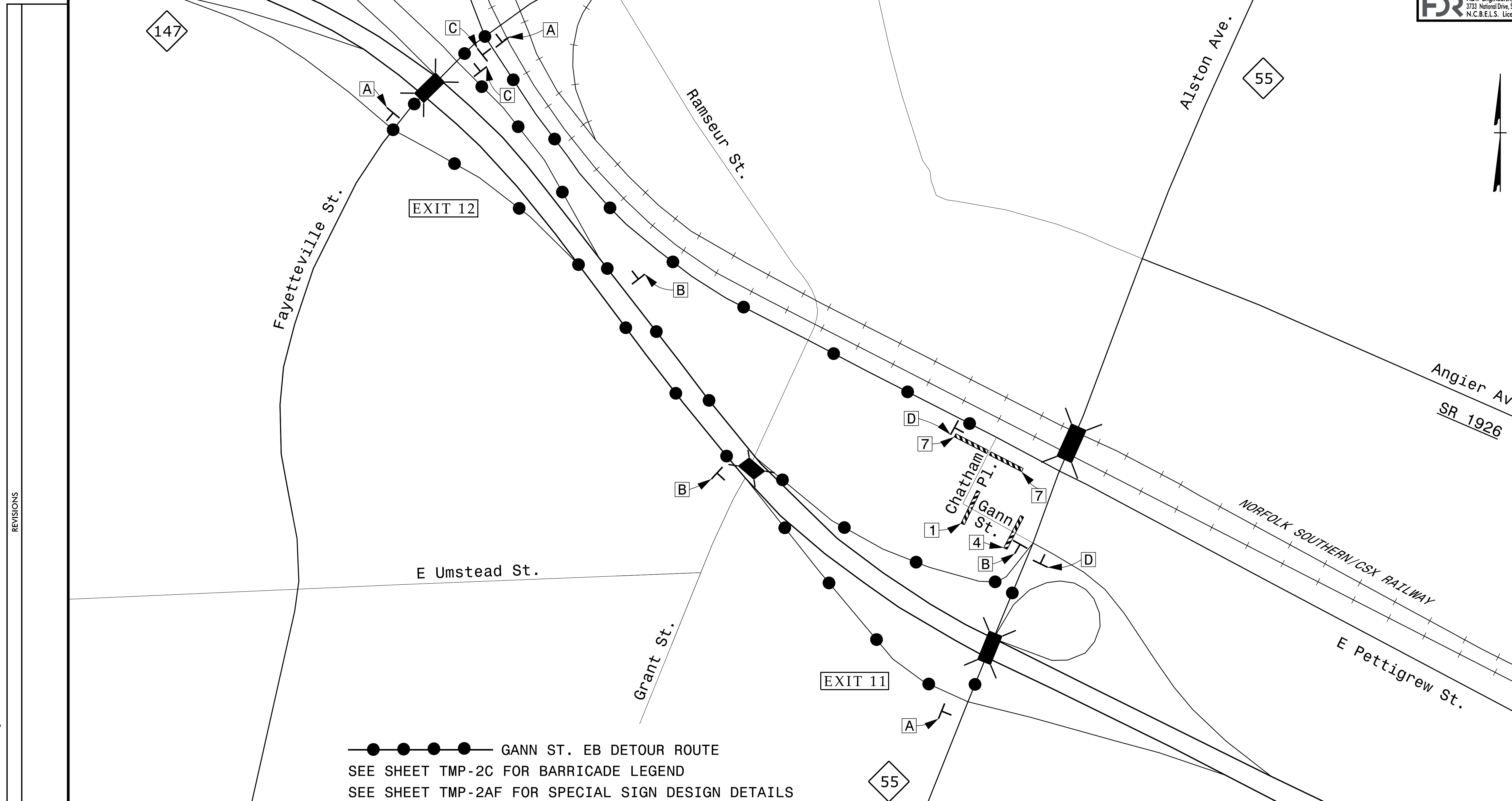

REVISIONS

PLOT DRIVER: NCDOT_color_eng_50.plt
 USER: erbrooks
 DATE: 5/13/2016
 TIME: 10:40:22 AM
 FILE: c:\pwworking\tpa\048729\U-3308_TMP_TMP-02C thru 02AB.dgn

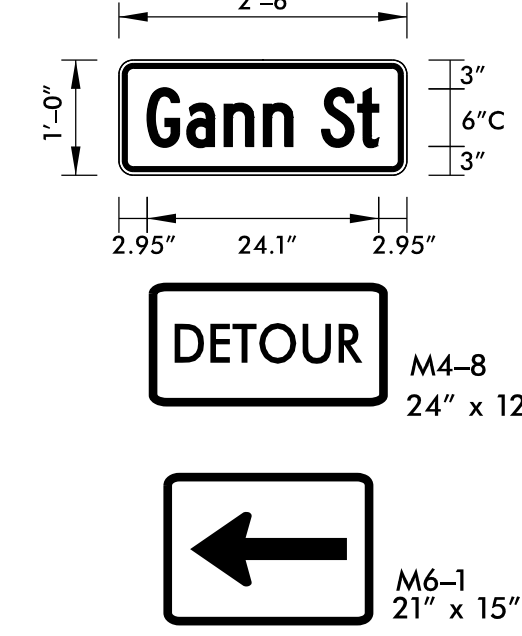
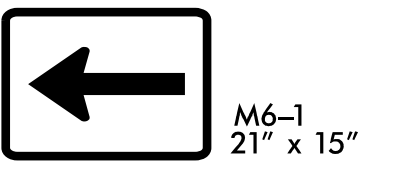
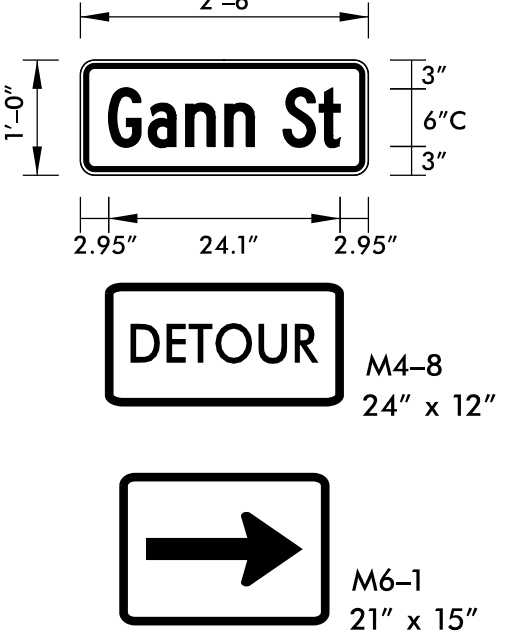
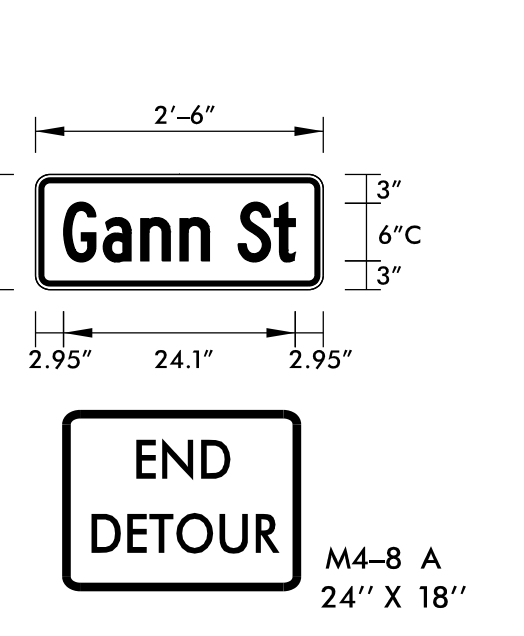
<p>A</p> 	<p>B</p> 	<p>C</p> 	<p>D</p> 
---	--	---	---

DOCUMENT NOT CONSIDERED FINAL
UNLESS ALL SIGNATURES COMPLETED

APPROVED:  DATE: 5/13/2016

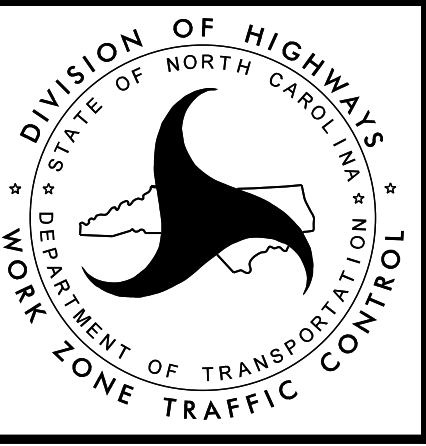

GANN STREET
DETOUR ROUTE

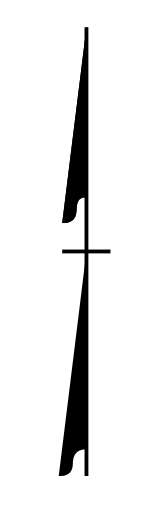

REVISIONS

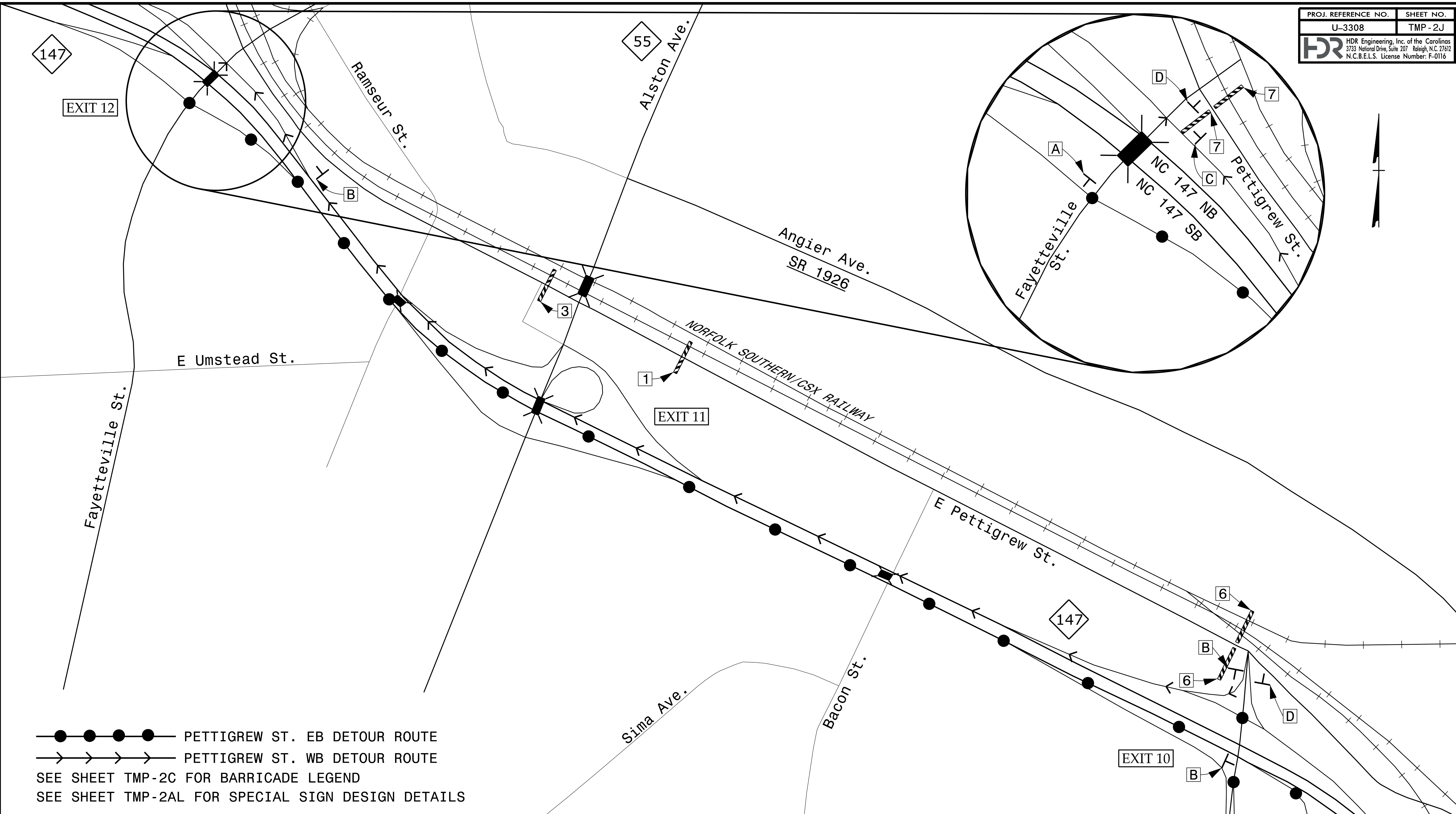

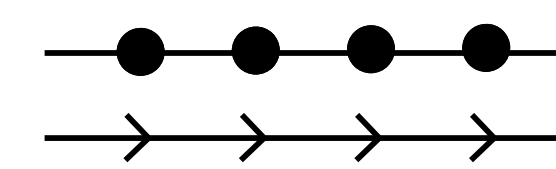
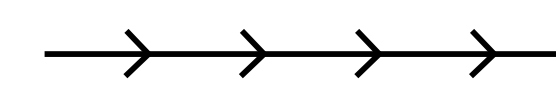

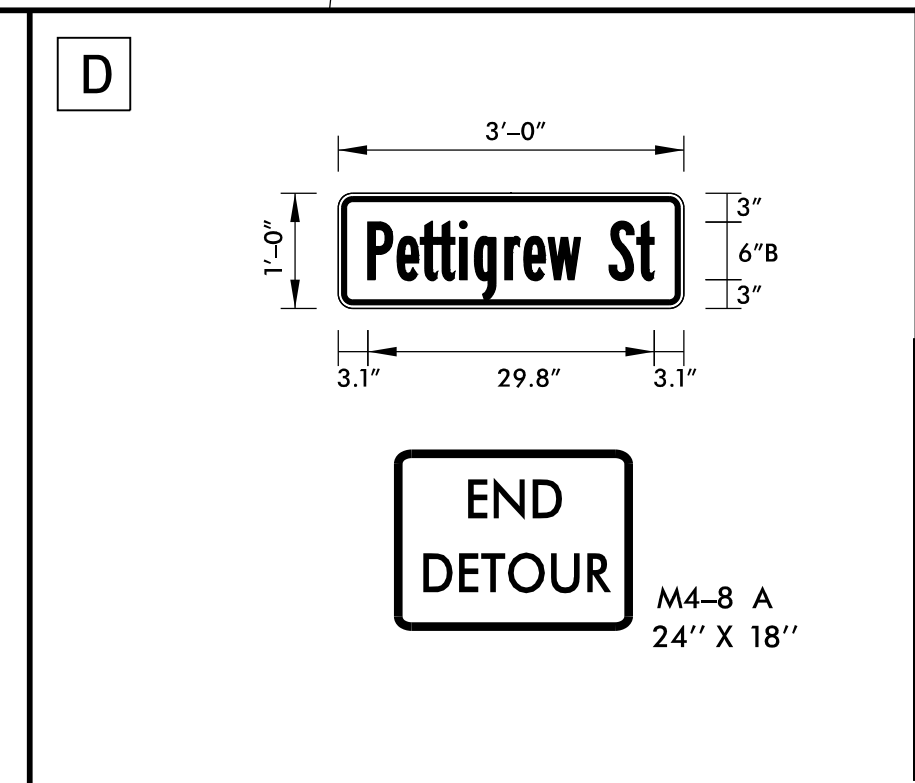
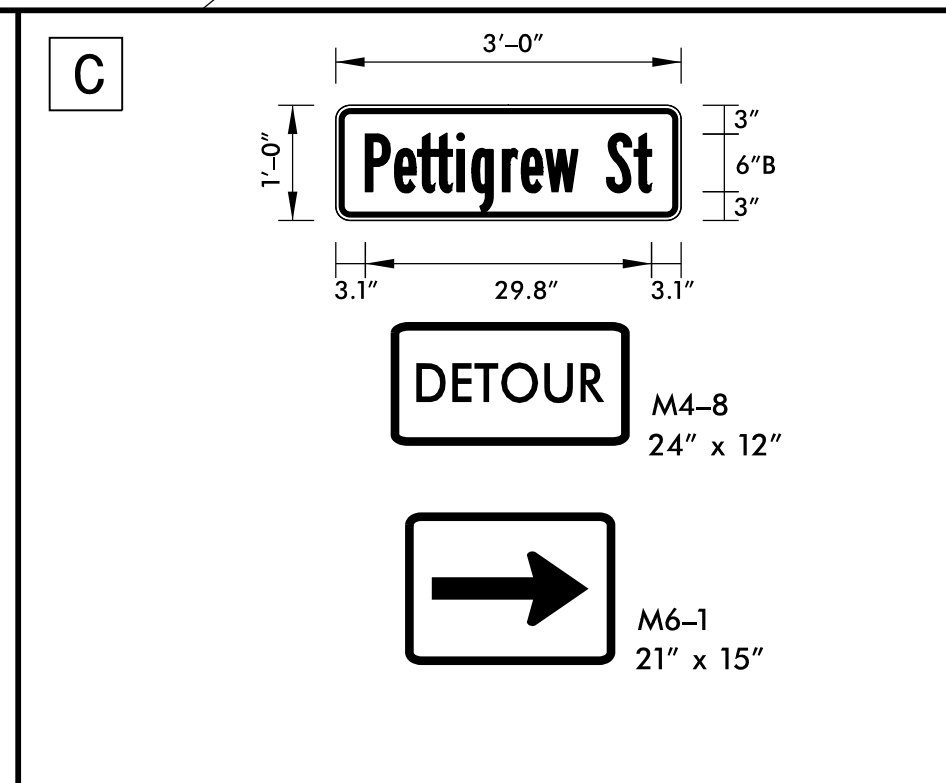
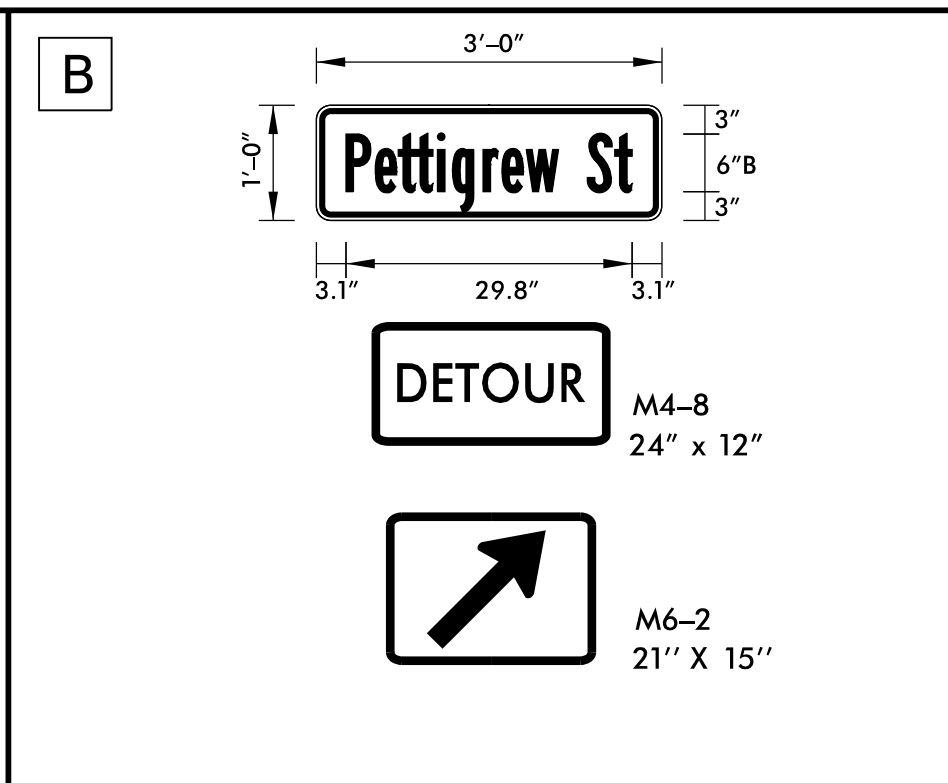
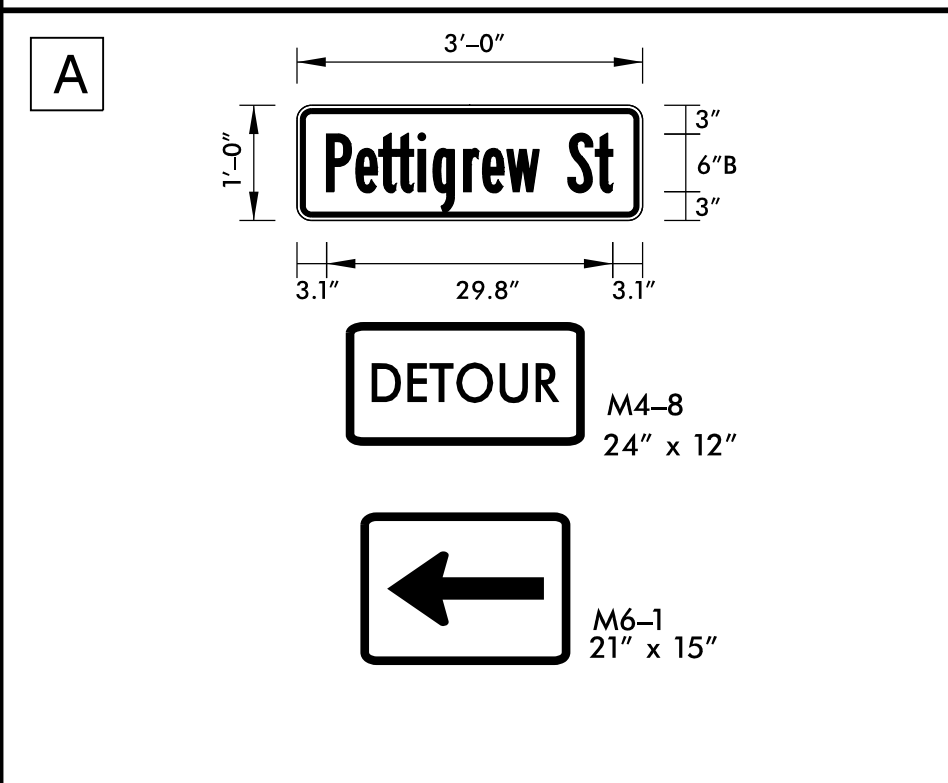
 PETTIGREW ST. EB DETOUR ROUTE

 PETTIGREW ST. WB DETOUR ROUTE
 SEE SHEET TMP-2C FOR BARRICADE LEGEND
 SEE SHEET TMP-2AL FOR SPECIAL SIGN DESIGN DETAILS

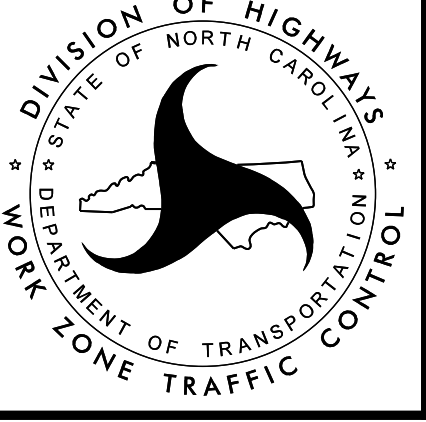

DOCUMENT NOT CONSIDERED FINAL
UNLESS ALL SIGNATURES COMPLETED

APPROVED:  DATE: 5/13/2016



PETTIGREW STREET
DETOUR ROUTE

PLOT DRIVER: NCDOT_pdf_color_eng_50.ppt
 USER: erbrooks
 PENTABLE: NCDOT_tcp.tbl
 DATE: 5/13/2016
 TIME: 10:40:24 AM
 FILE: c:\pwworking\tpa\048729\U-3308_TMP-TMP-02C thru 02AB.dgn

REVISIONS

PLOT DRIVER: NCDOT_pdf_color_eng_50.pit
 USER: erbrooks
 DATE: 5/13/2016
 TIME: 10:40:27 AM
 FILE: c:\pwworking\tpa\d048729\U-3308_TMP-02C thru 02AB.dgn

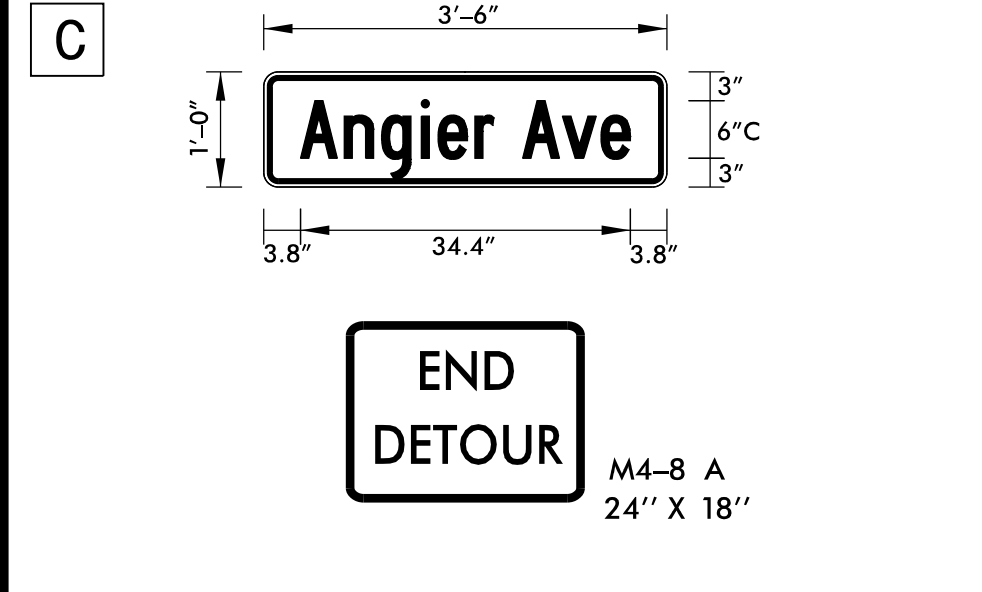
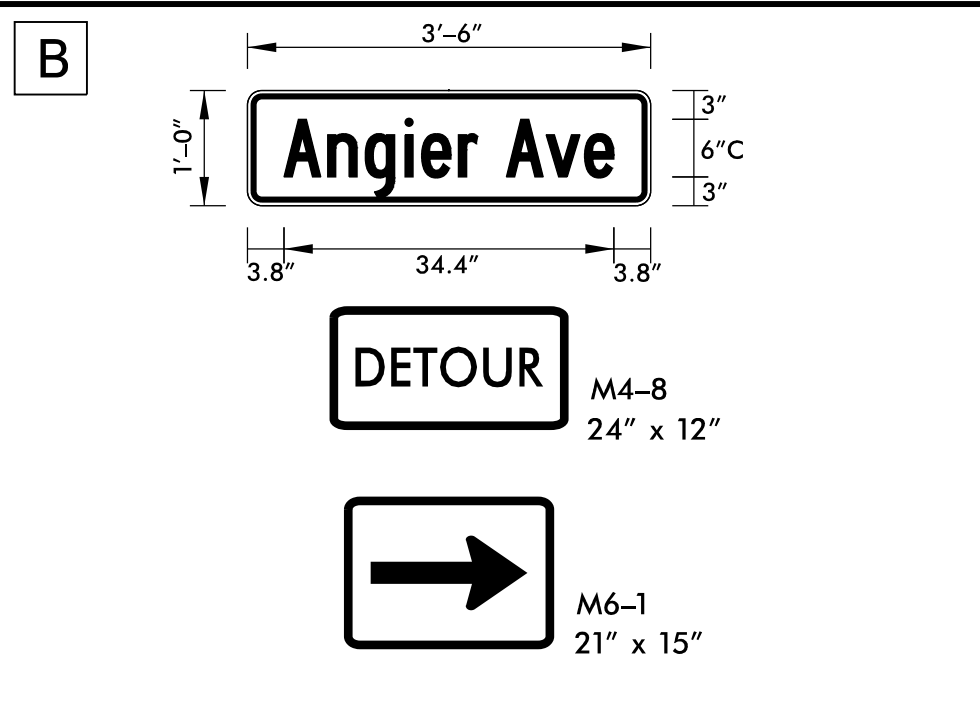
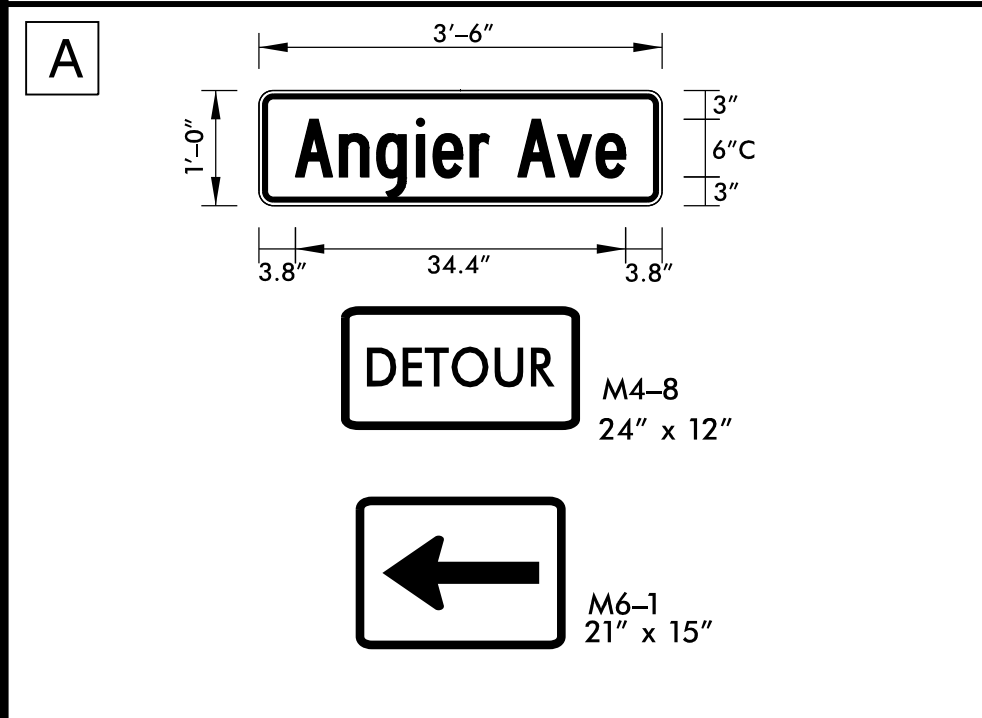
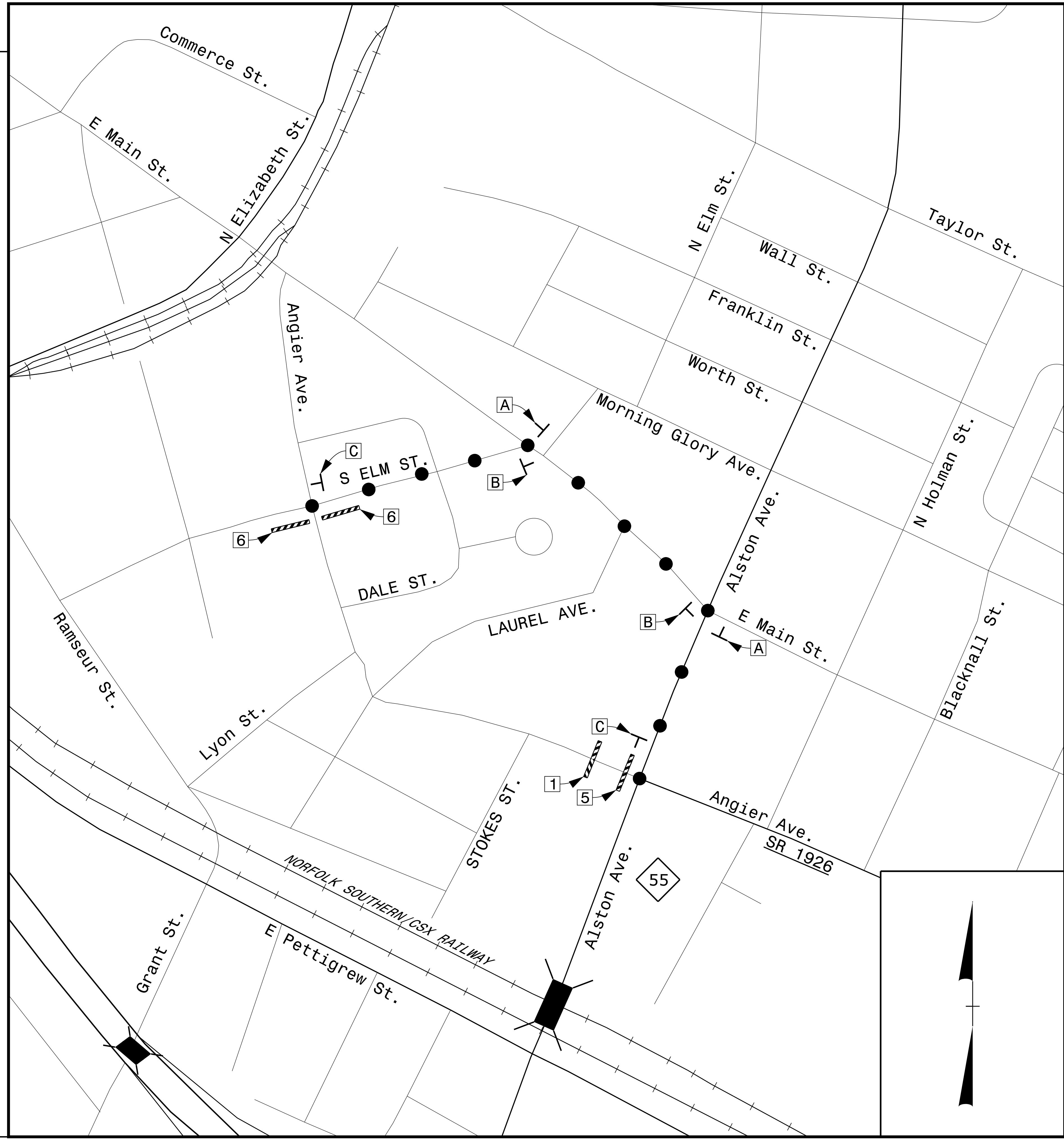

SEE SHEET TMP-2C FOR BARRICADE LEGEND
 SEE SHEET TMP-2AD FOR SPECIAL SIGN DESIGN DETAILS

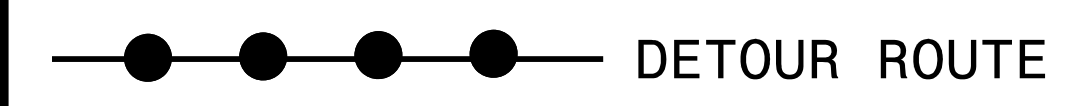

**DOCUMENT NOT CONSIDERED FINAL
 UNLESS ALL SIGNATURES COMPLETED**

APPROVED:  DATE: 5/13/2016

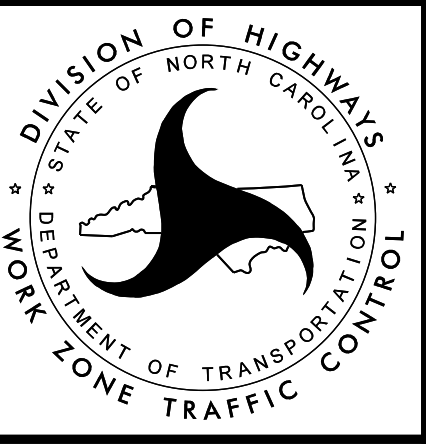

**ANGIER AVENUE
 DETOUR ROUTE**

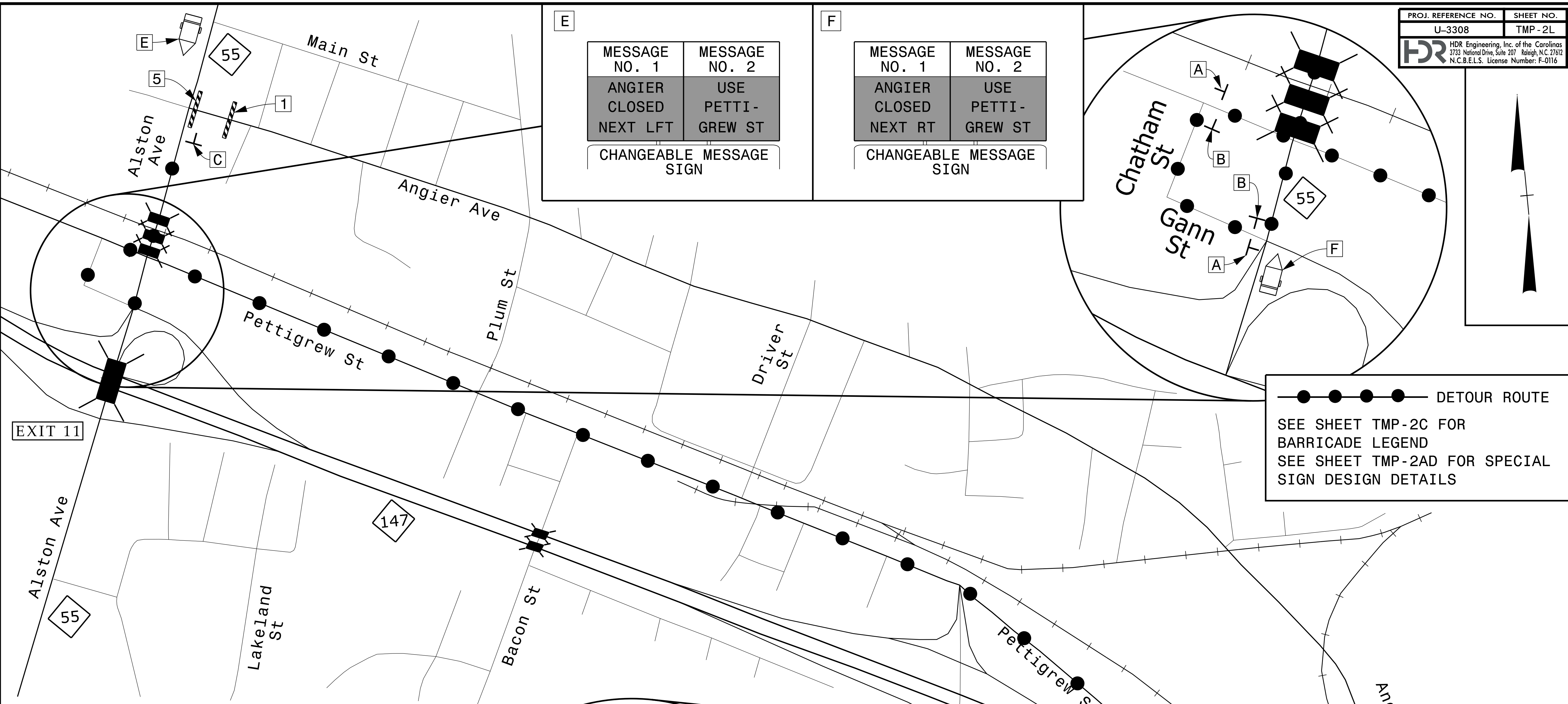
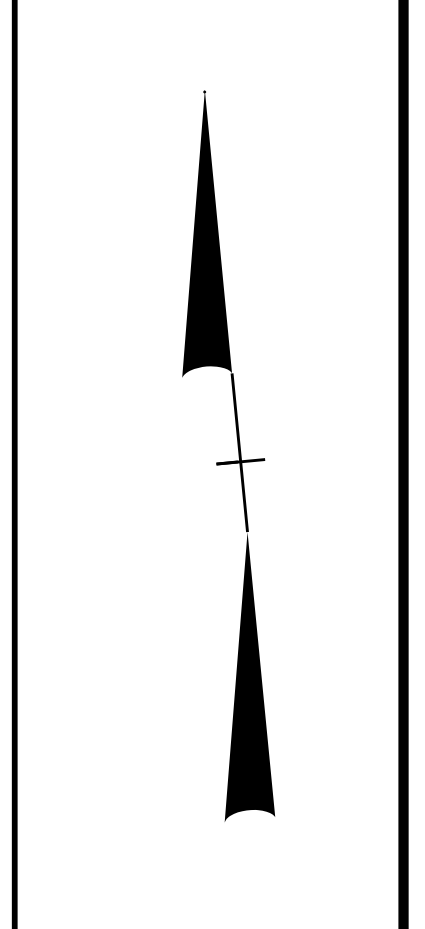

E	MESSAGE NO. 1	MESSAGE NO. 2
	ANGIER CLOSED NEXT LFT	USE PETTI-GREW ST
	CHANGEABLE MESSAGE SIGN	

F	MESSAGE NO. 1	MESSAGE NO. 2
	ANGIER CLOSED NEXT RT	USE PETTI-GREW ST
	CHANGEABLE MESSAGE SIGN	

 DETOUR ROUTE
 SEE SHEET TMP-2C FOR BARRICADE LEGEND
 SEE SHEET TMP-2AD FOR SPECIAL SIGN DESIGN DETAILS

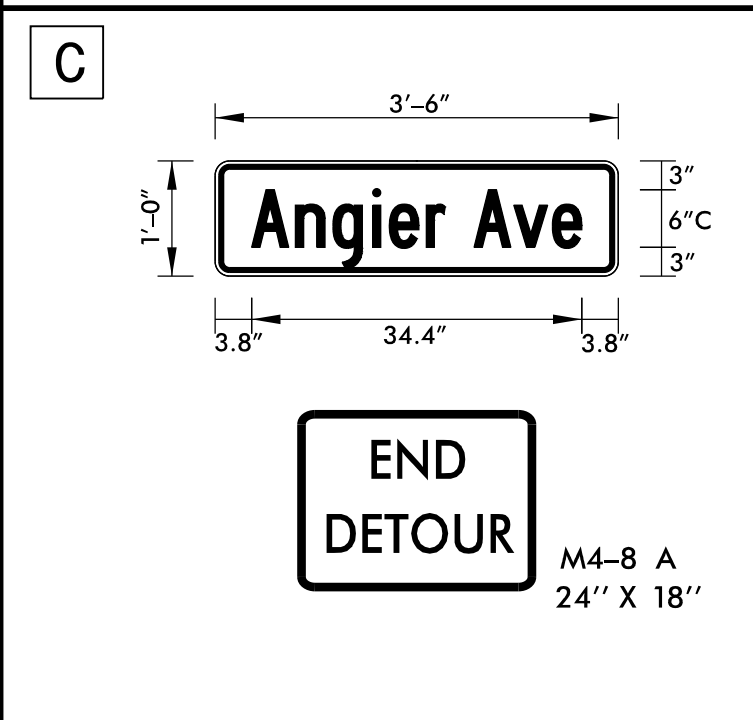
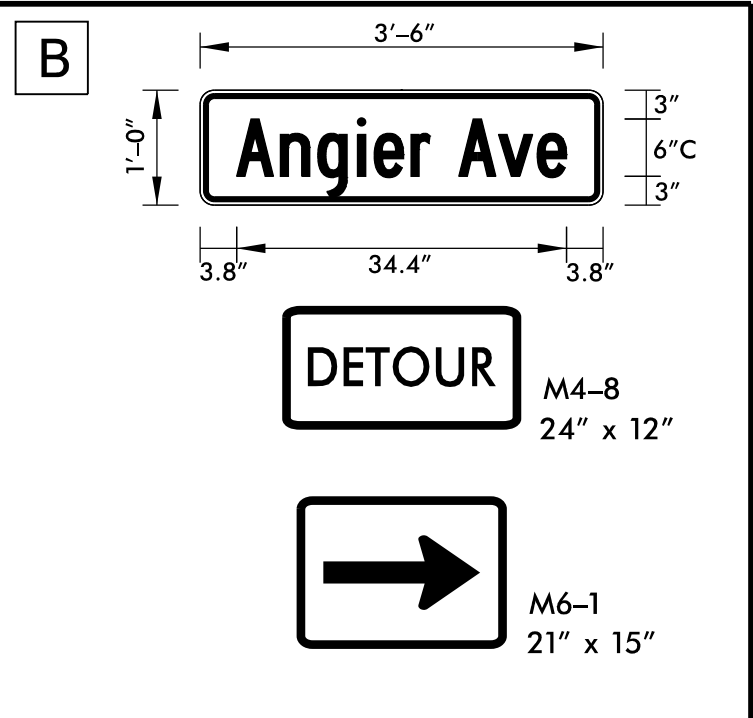
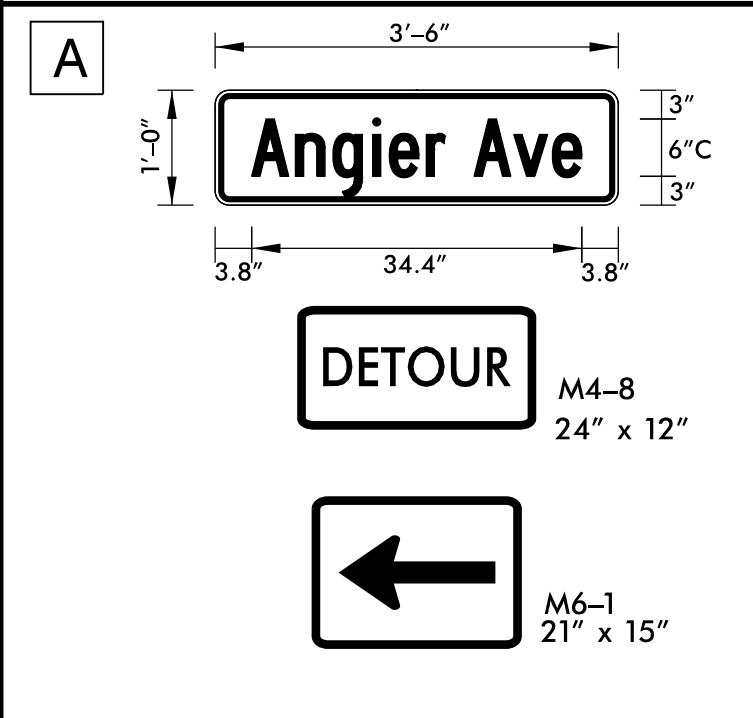

D

MESSAGE NO. 1	MESSAGE NO. 2
ANGIER CLOSED @ ALSTON	FOLLOW DETOUR TO NC 55
CHANGEABLE MESSAGE SIGN	

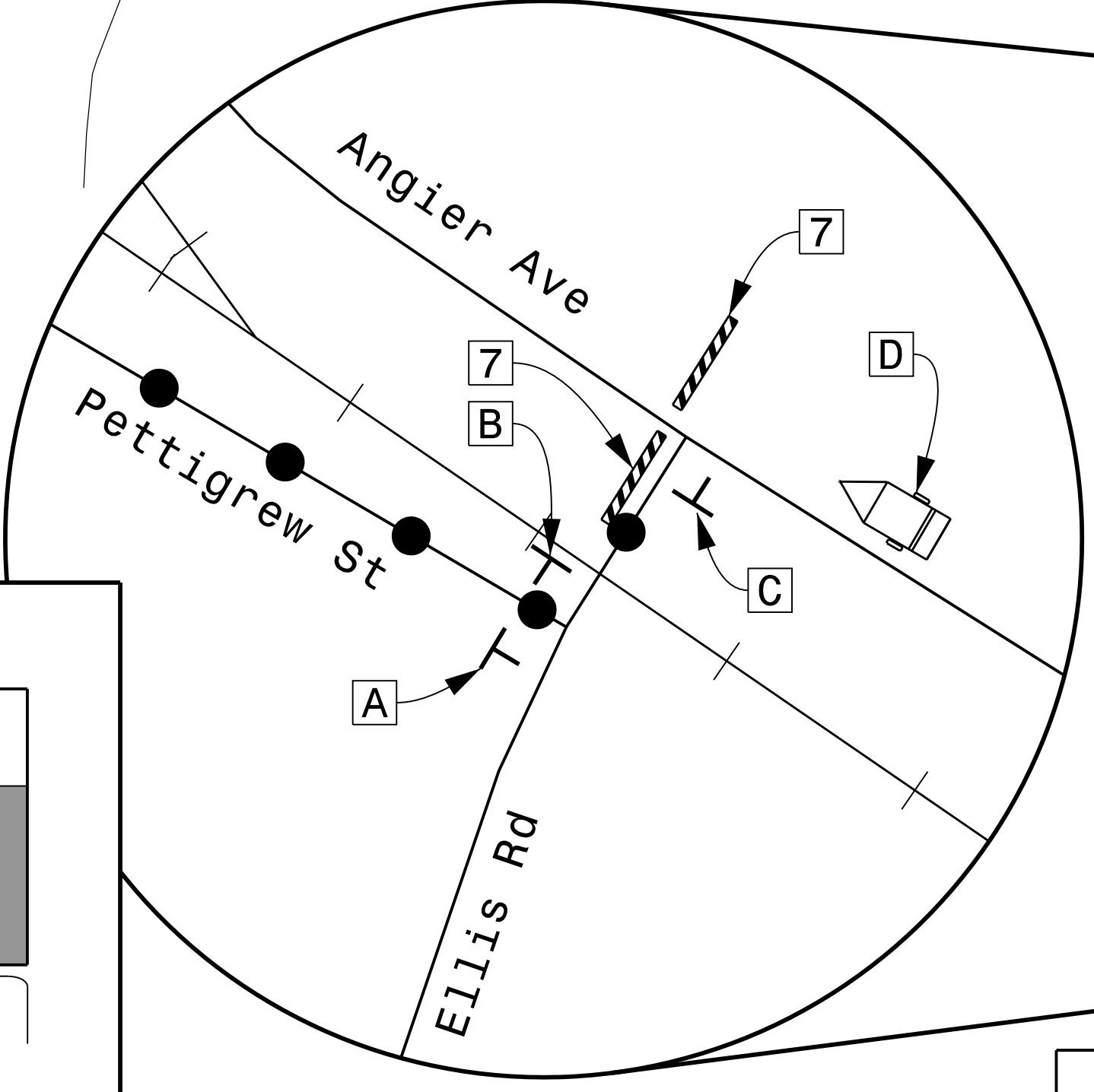

APPROVED  DATE: 5/13/2016





ANGIER AVENUE (SR 1926)
DETOUR ROUTE

DOCUMENT NOT CONSIDERED FINAL
UNLESS ALL SIGNATURES COMPLETED

PLOT DRIVER: NCDOT_pdf_color_eng_50.pit
 USER: erbrooks
 DATE: 5/13/2016
 TIME: 10:40:29 AM
 FILE: c:\pwworking\paw\0487729\U-3308_TMP-TMP-02C thru 02AB.dgn

REVISIONS

PLOT DRIVER: NCDOT_pdf_color_eng_50.plt
 USER: erbrooks
 DATE: 5/13/2016
 TIME: 10:40:30 AM
 FILE: c:\pwworking\tpa\d048729\U-3308_TMP-TMP-02C thru 02AB.dgn

REVISIONS

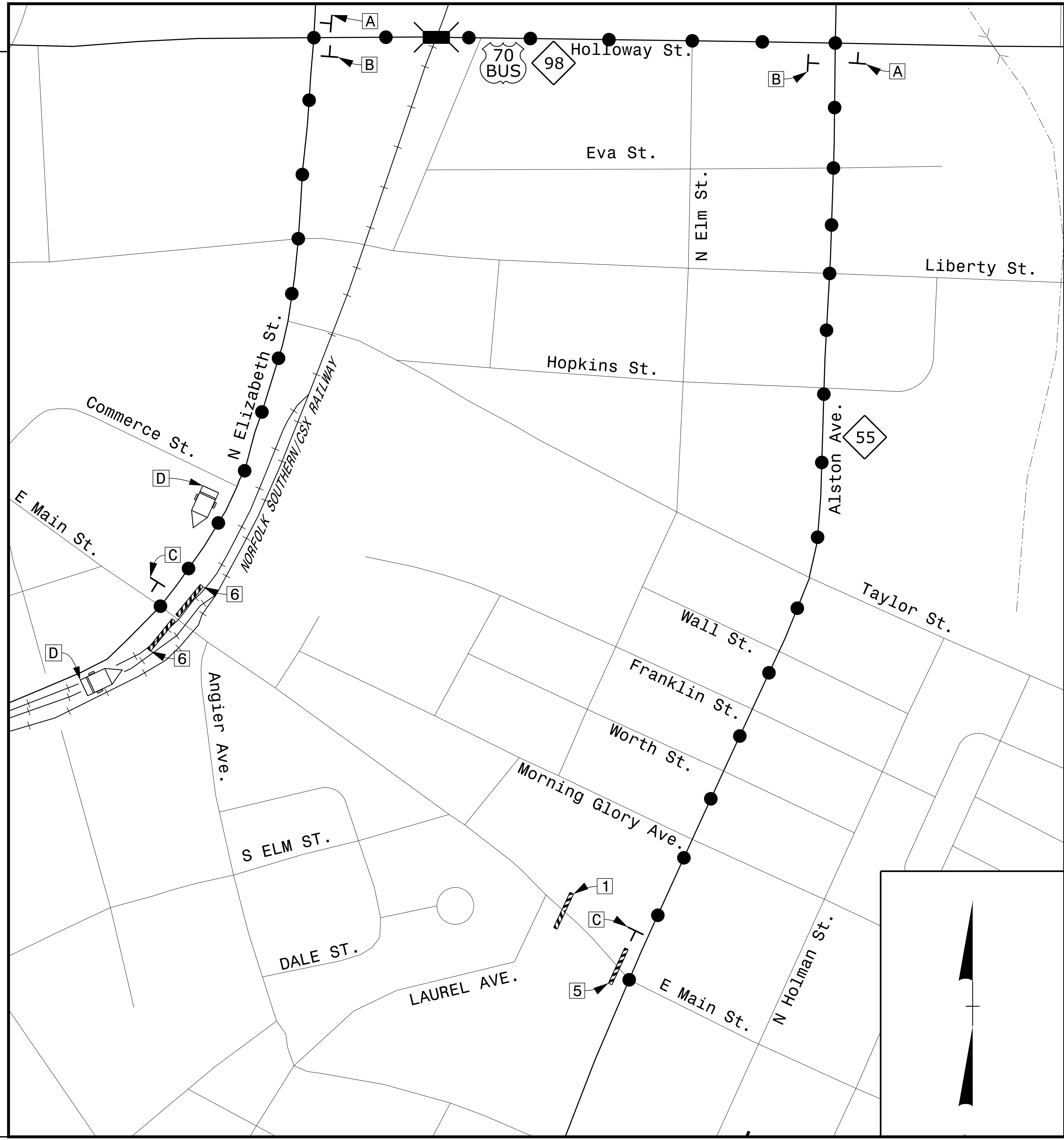

PROJ. REFERENCE NO. U-3308	SHEET NO. TMP-2M
-------------------------------	---------------------

HDR HDR Engineering, Inc. of the Carolinas
 3733 National Drive, Suite 207 Raleigh, N.C. 27612
 N.C.B.E.L.S. License Number: F-0116

●—●—●—●— DETOUR ROUTE

SEE SHEET TMP-2C FOR BARRICADE LEGEND
 SEE SHEET TMP-2AJ FOR SPECIAL SIGN DESIGN DETAILS

<p>A</p>	<p>B</p>								
<p>C</p>	<p>D</p> <table border="1"> <tr> <td>MESSAGE NO. 1</td> <td>MESSAGE NO. 2</td> </tr> <tr> <td>MAIN ST</td> <td>TRUCKS</td> </tr> <tr> <td>CLOSED @</td> <td>USE ALT</td> </tr> <tr> <td>ALSTON</td> <td>ROUTE</td> </tr> </table> <p>CHANGEABLE MESSAGE SIGN</p>	MESSAGE NO. 1	MESSAGE NO. 2	MAIN ST	TRUCKS	CLOSED @	USE ALT	ALSTON	ROUTE
MESSAGE NO. 1	MESSAGE NO. 2								
MAIN ST	TRUCKS								
CLOSED @	USE ALT								
ALSTON	ROUTE								

DOCUMENT NOT CONSIDERED FINAL
 UNLESS ALL SIGNATURES COMPLETED

APPROVED: *R. Erskine Brooks* DATE: 5/13/2016

<p>SEAL</p>		<p>MAIN STREET DETOUR ROUTE</p>
-------------	--	--



SEE SHEET TMP-2C FOR BARRICADE LEGEND
 SEE SHEET TMP-2AJ FOR SPECIAL SIGN DESIGN DETAILS

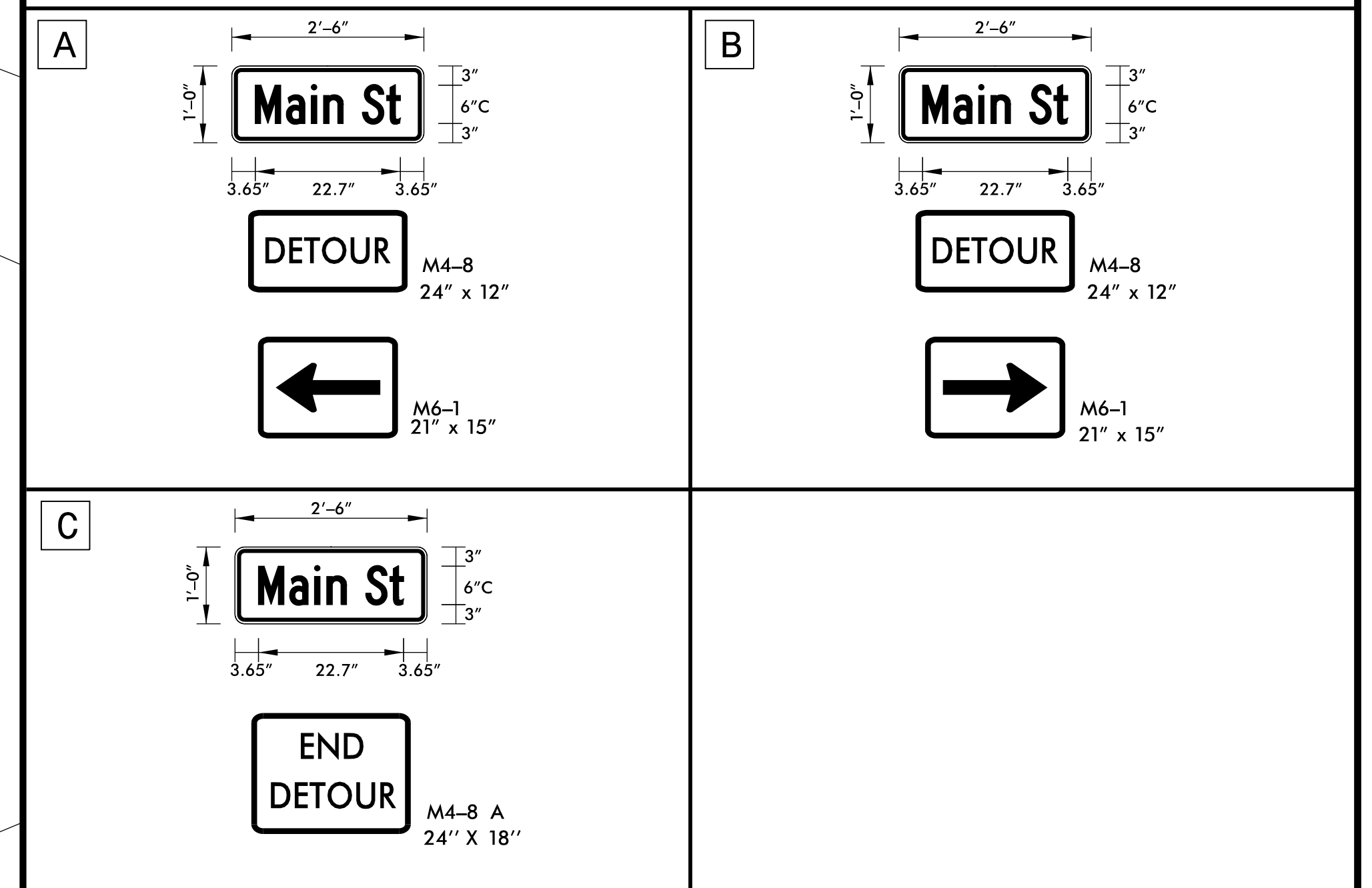

REVISIONS

PLOT DRIVER: NCDOT_color_eng_50.plt
 USER: erbrooks
 DATE: 5/13/2016
 TIME: 10:40:32 AM
 FILE: c:\pwworking\tpa\d048729\U-3308_TMP-TMP-02C thru 02AB.dgn

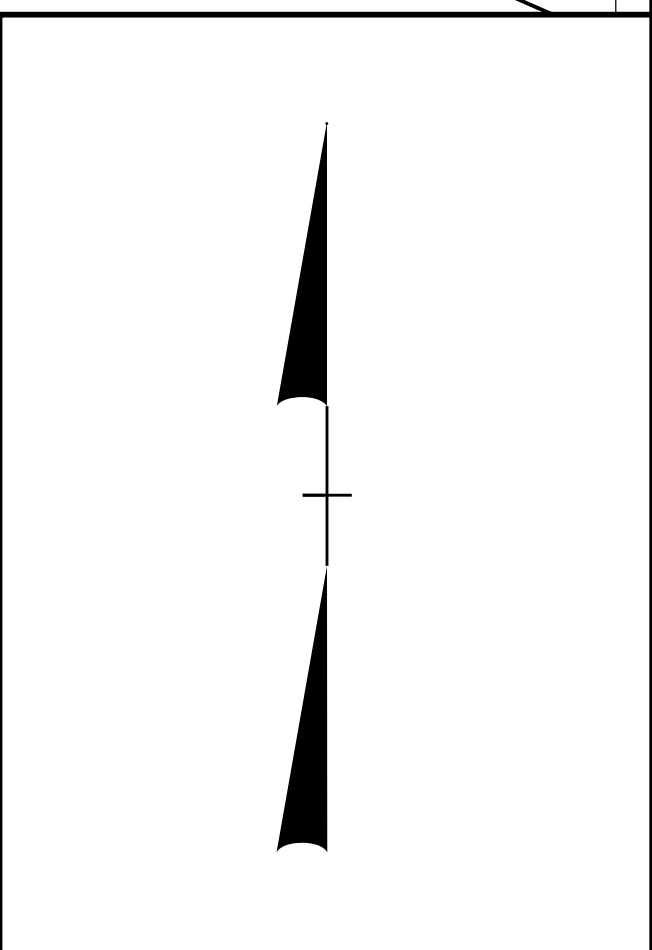

DOCUMENT NOT CONSIDERED FINAL
 UNLESS ALL SIGNATURES COMPLETED

APPROVED  DATE: 5/13/2016

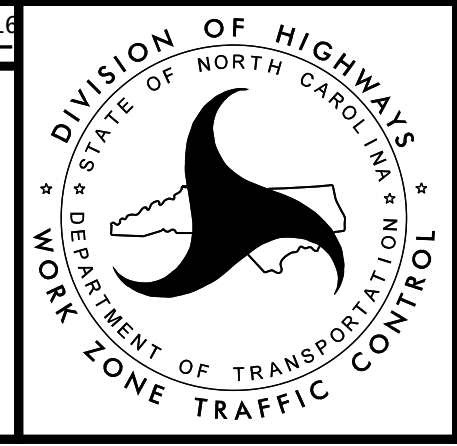
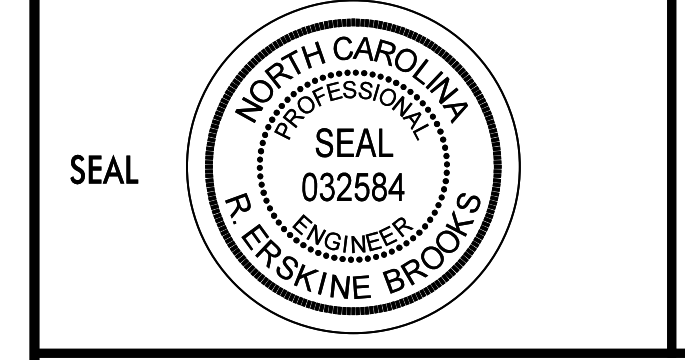

MAIN STREET
 DETOUR ROUTE

147

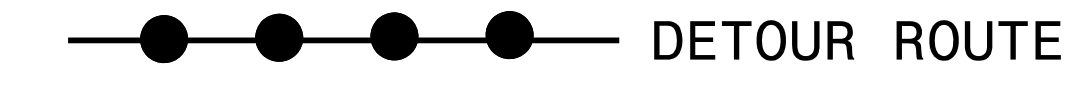

SEE SHEET TMP-2C FOR BARRICADE LEGEND
 SEE SHEET TMP-2AK FOR SPECIAL SIGN DESIGN DETAILS

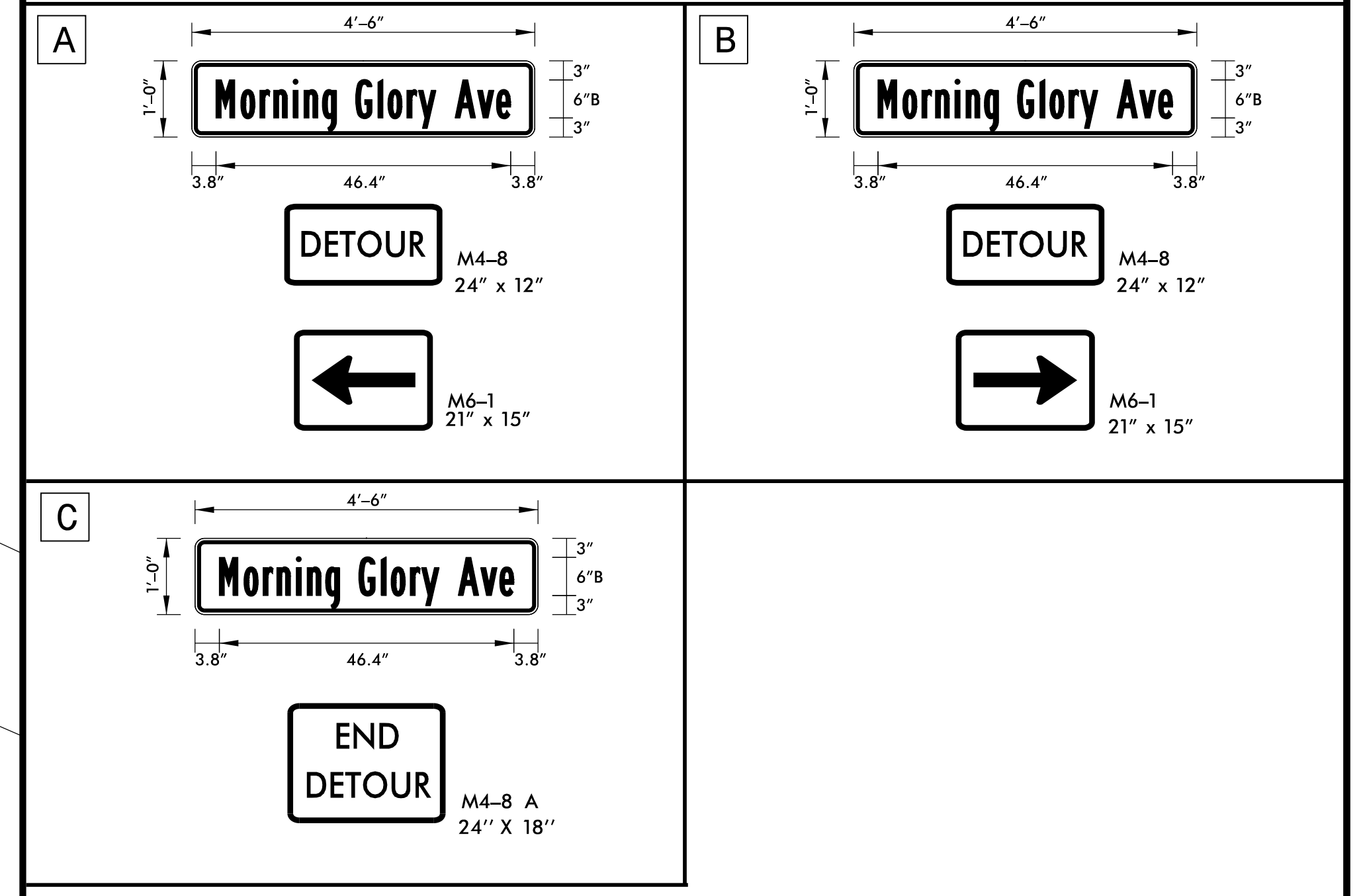

REVISIONS

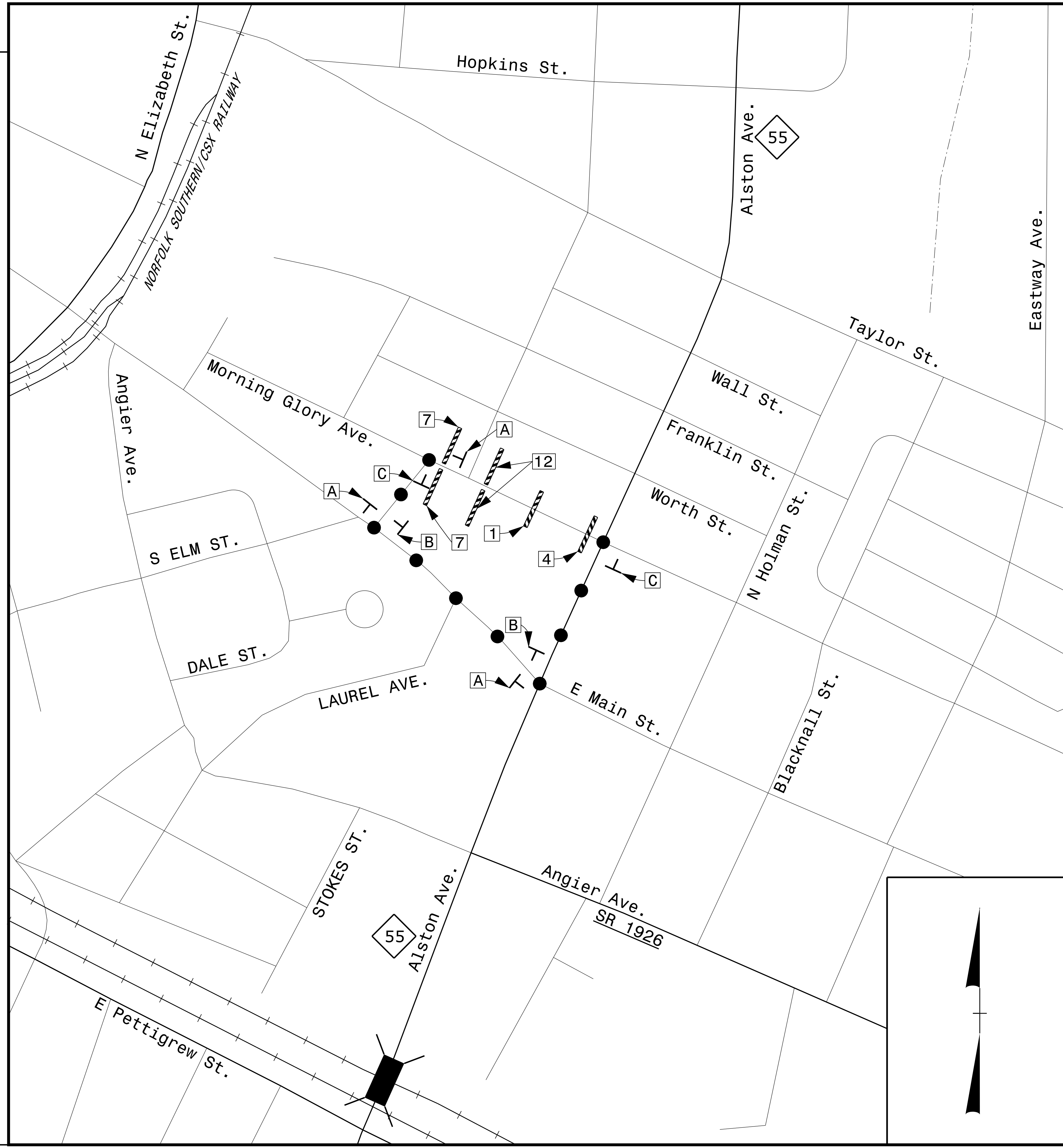

PLOT DRIVER: NCDOT_pdf_color_eng_50.plt
 USER: erbrooks
 DATE: 5/13/2016
 TIME: 10:40:33 AM
 FILE: c:\pwworking\tpa\d048729\U-3308_TMP-TMP-02C thru 02AB.dgn

DOCUMENT NOT CONSIDERED FINAL
 UNLESS ALL SIGNATURES COMPLETED

APPROVED:  DATE: 5/13/2016

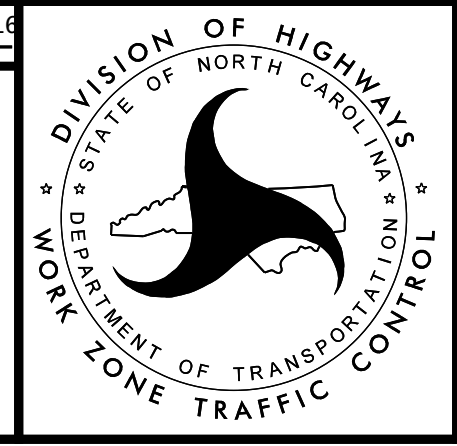

MORNING GLORY AVENUE
 DETOUR ROUTE

PROJ. REFERENCE NO.	SHEET NO.
U-3308	TMP-2P
 HDR Engineering, Inc. of the Carolinas 3733 National Drive, Suite 207 Raleigh, N.C. 27612 N.C.B.E.L.S. License Number: F-0116	



SEE SHEET TMP-2C FOR BARRICADE LEGEND
 SEE SHEET TMP-2AK FOR SPECIAL SIGN DESIGN DETAILS

REVISIONS

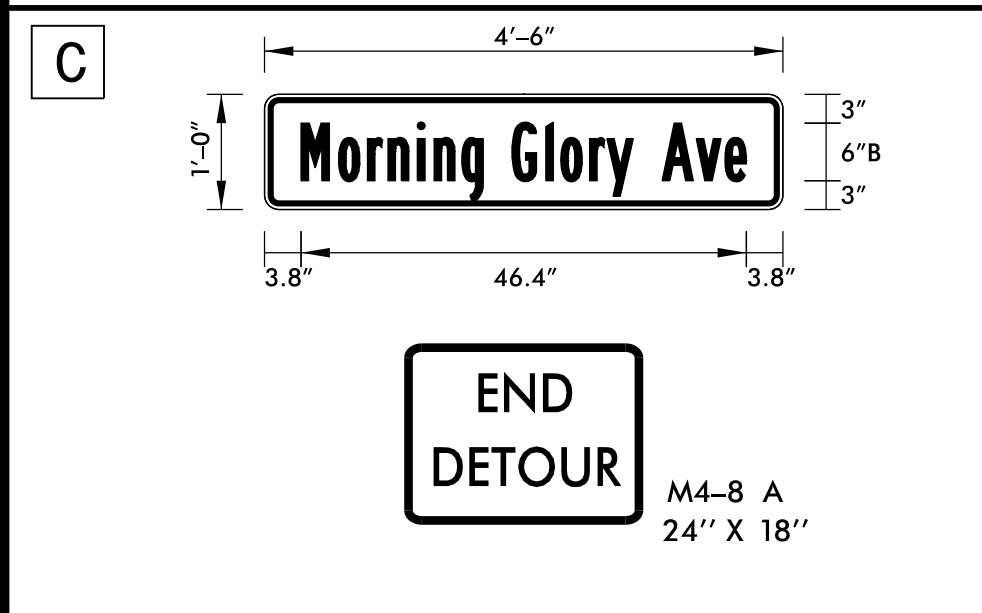
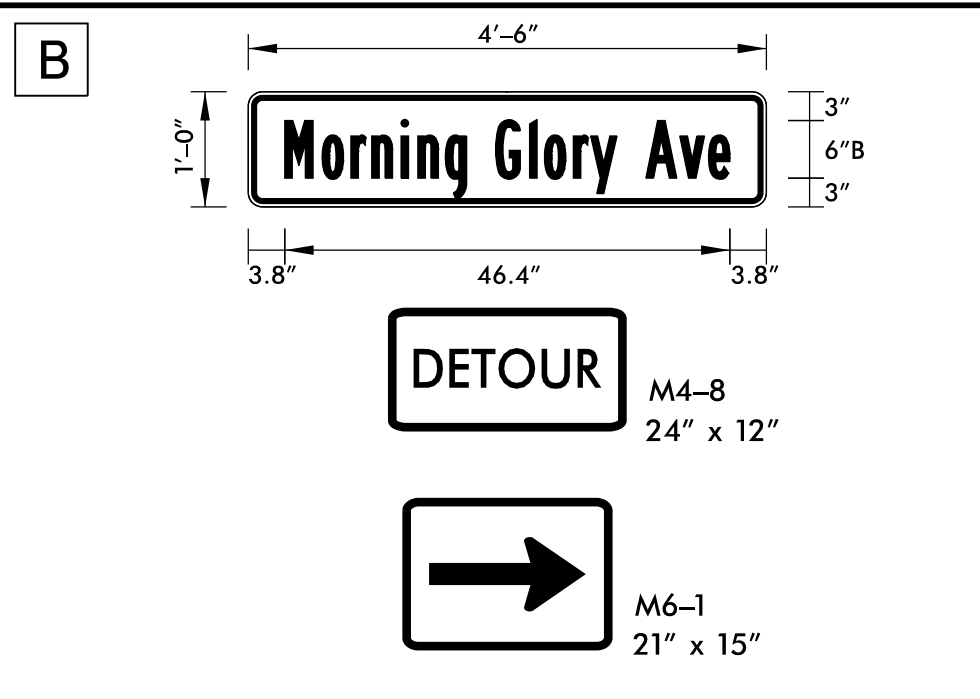
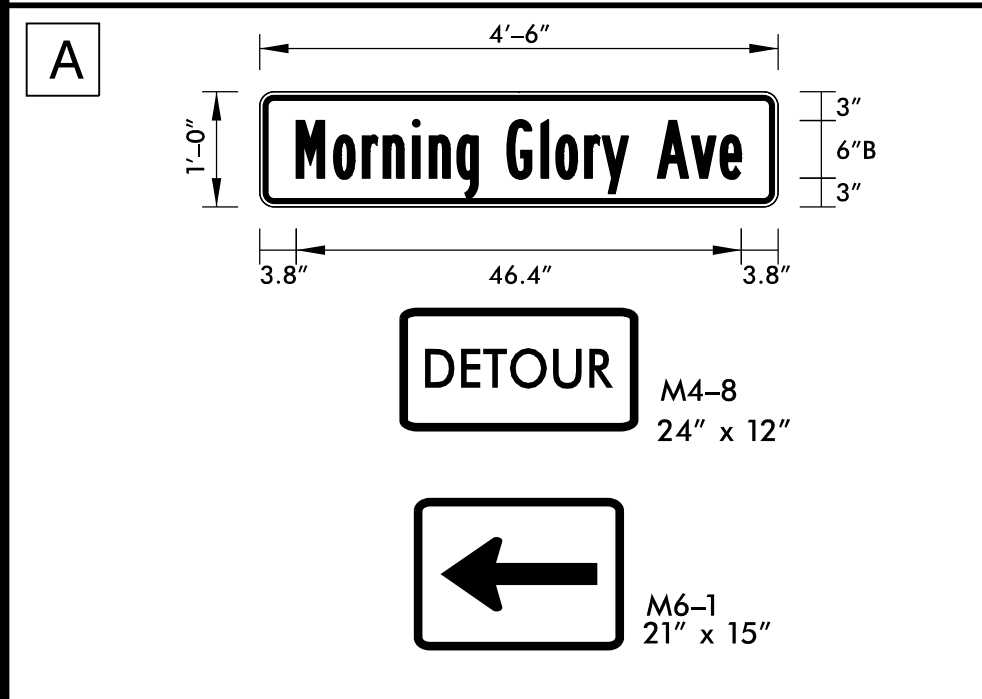
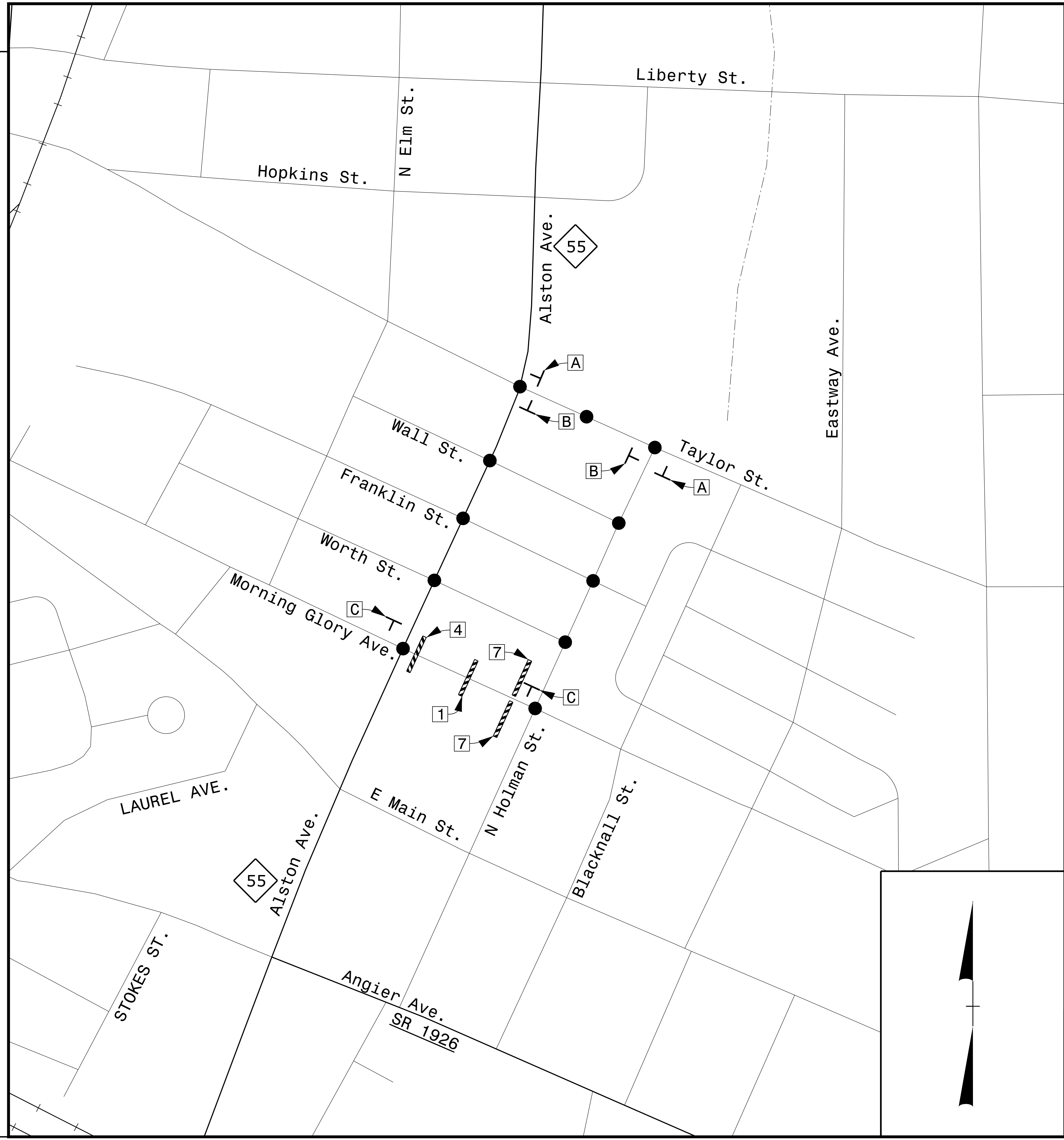

PLOT DRIVER: NCDOT_pdf_color_eng_50.plt
 USER: erbrooks
 DATE: 5/13/2016
 TIME: 10:40:35 AM
 FILE: c:\pwworking\tpa\d048729\U-3308_TMP-TMP-02C thru 02AB.dgn

DOCUMENT NOT CONSIDERED FINAL
 UNLESS ALL SIGNATURES COMPLETED

APPROVED:  DATE: 5/13/2016

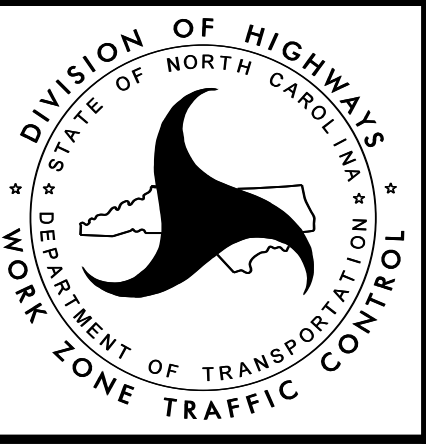

MORNING GLORY AVENUE
 DETOUR ROUTE

PROJ. REFERENCE NO.	SHEET NO.
U-3308	TMP-2Q
 HDR Engineering, Inc. of the Carolinas 3733 National Drive, Suite 207 Raleigh, N.C. 27612 N.C.B.E.L.S. License Number: F-0116	

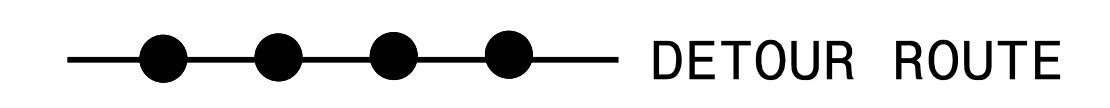

SEE SHEET TMP-2C FOR BARRICADE LEGEND
 SEE SHEET TMP-2AE & TMP-2AO FOR SPECIAL SIGN DESIGN DETAILS

REVISIONS

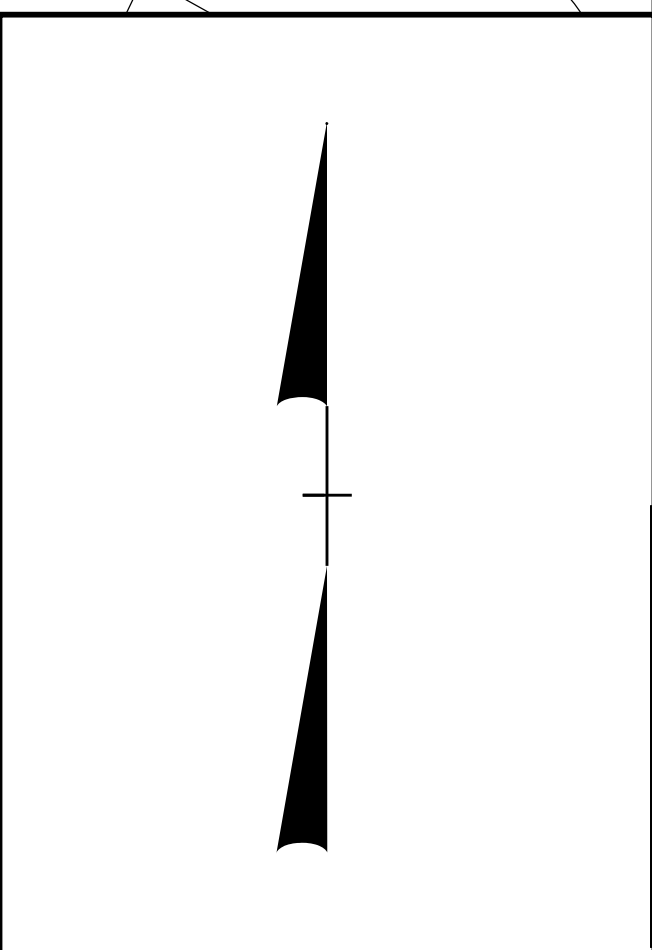
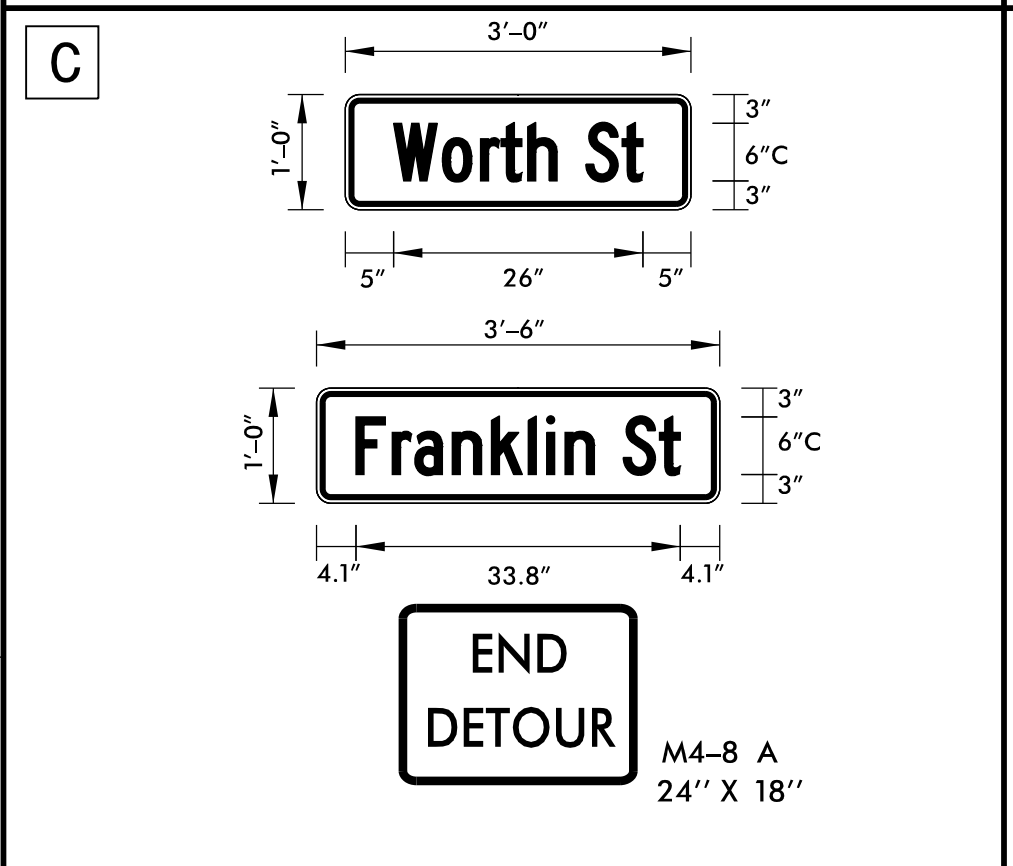
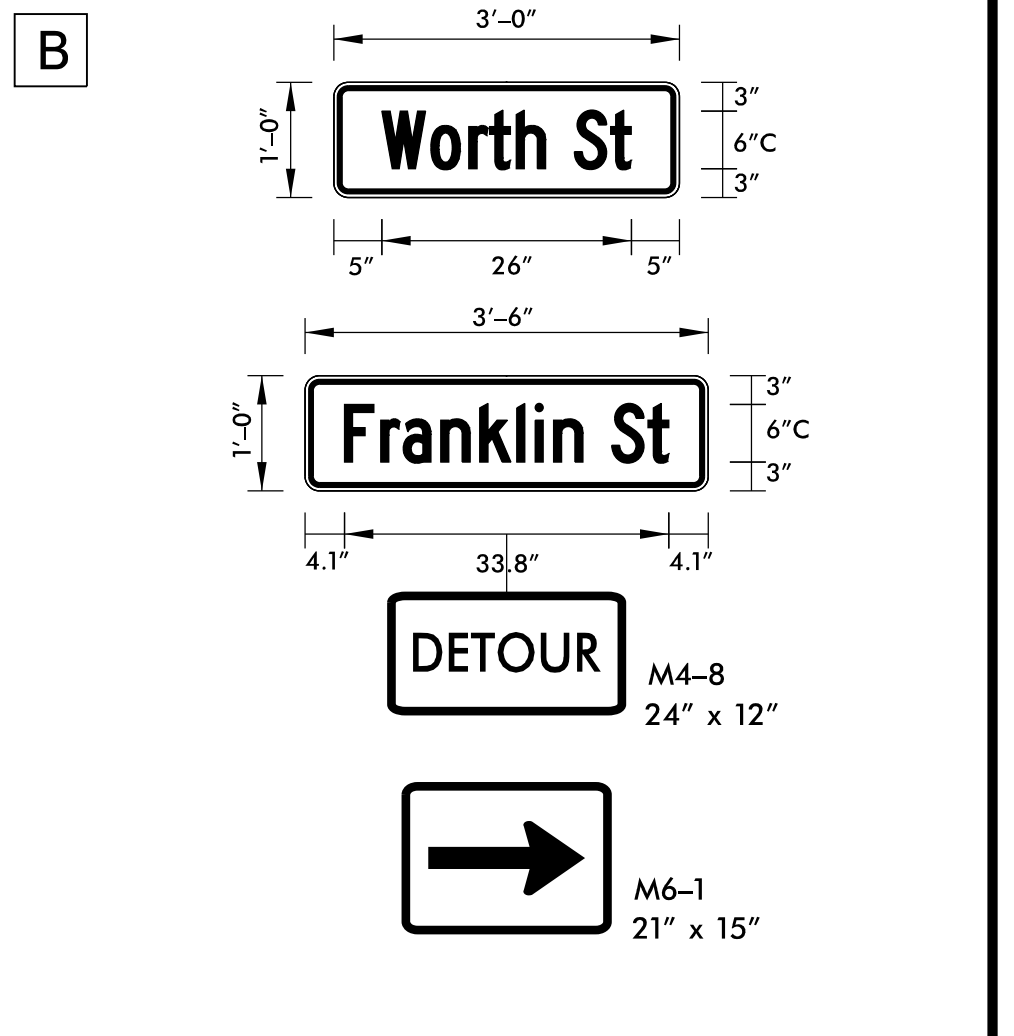
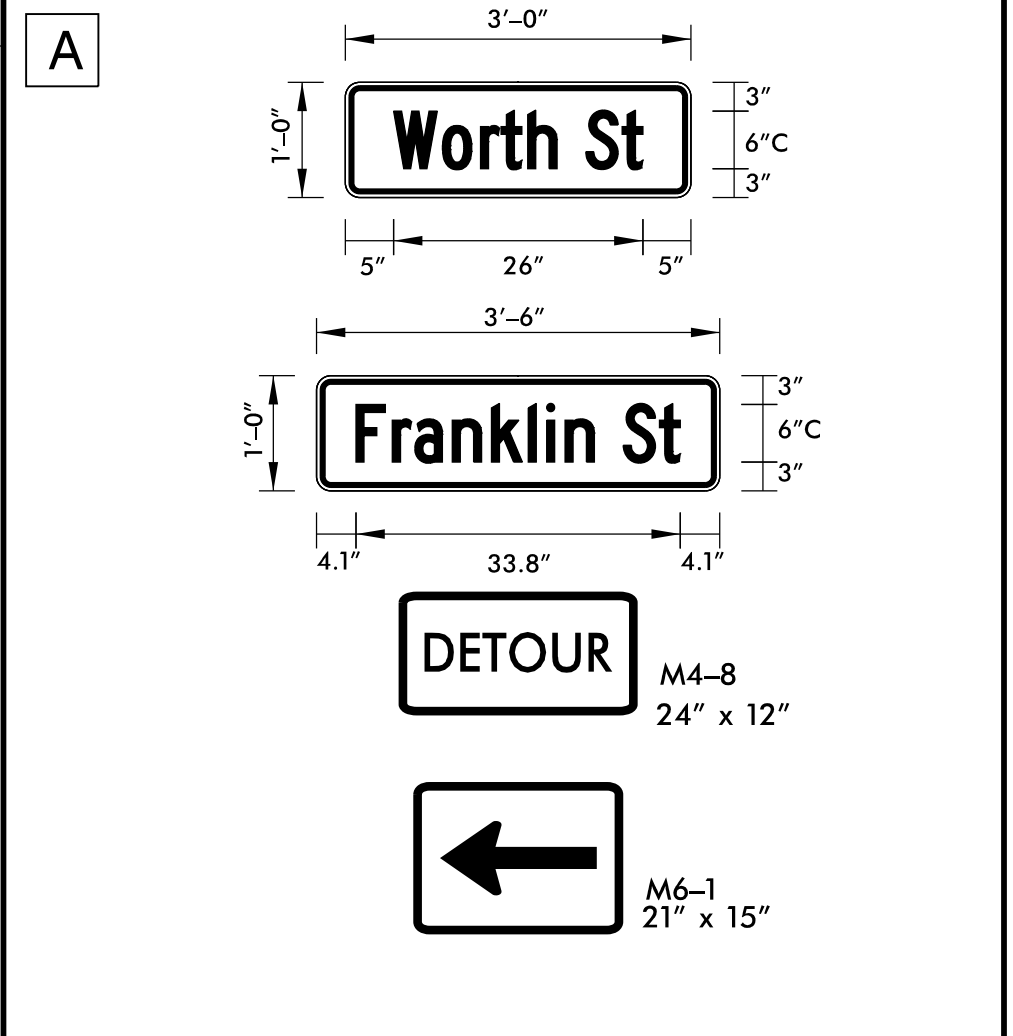
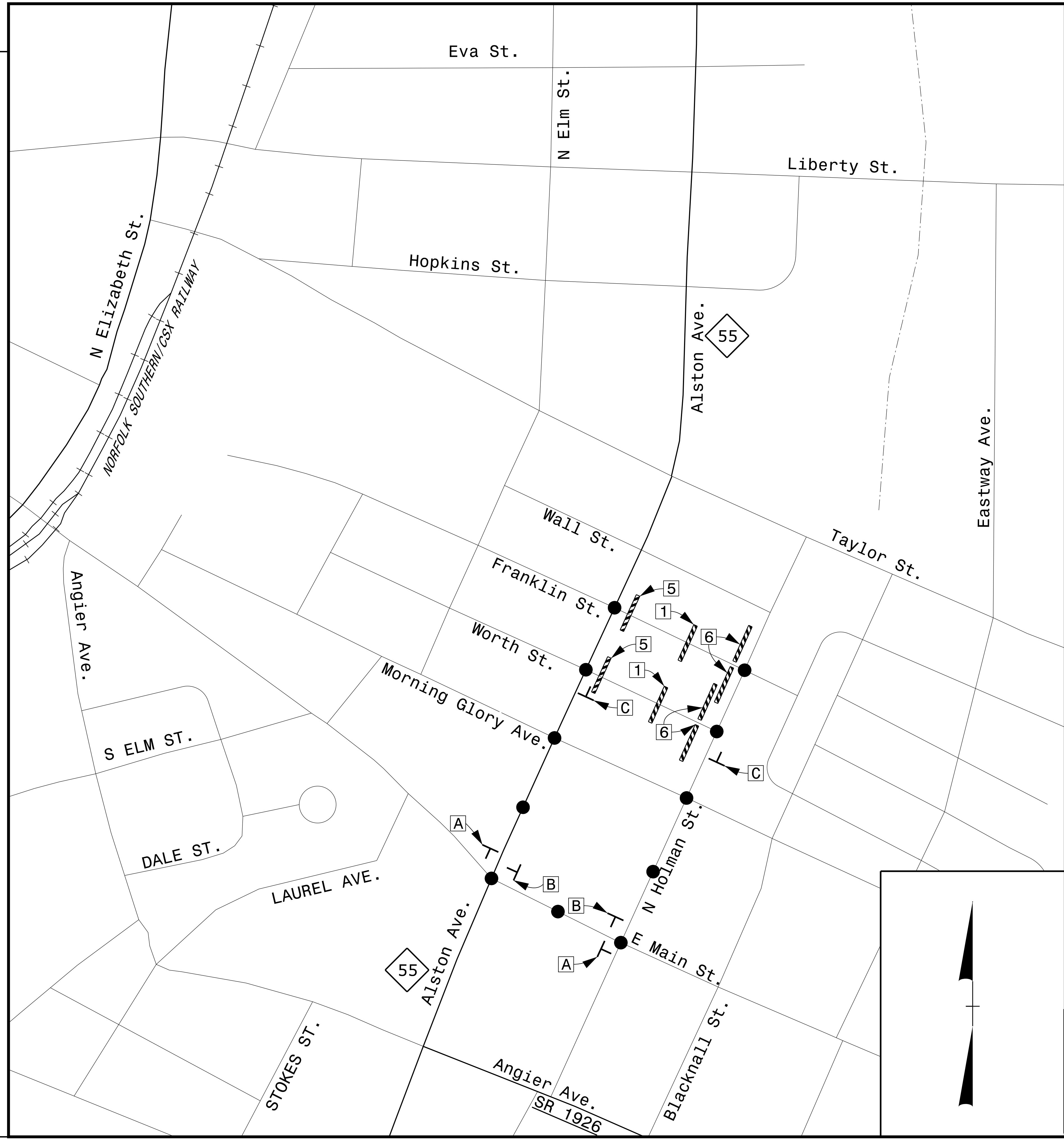

PLOT DRIVER: NCDOT_pdf_color_eng_50.plt
 USER: erbrooks
 DATE: 5/13/2016
 TIME: 10:40:37 AM
 FILE: c:\pwworking\tpa\048729\U-3308_TMP-TMP-02C thru 02AB.dgn

DOCUMENT NOT CONSIDERED FINAL
 UNLESS ALL SIGNATURES COMPLETED

APPROVED:  DATE: 5/13/2016

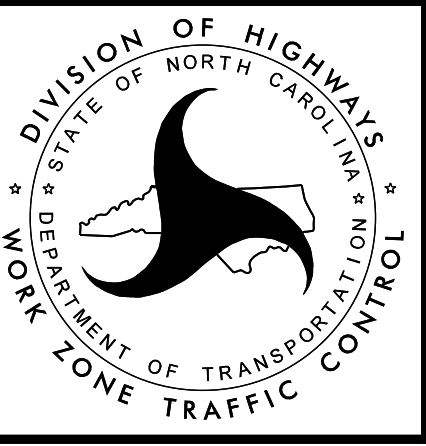

WORTH STREET
 FRANKLIN STREET
 DETOUR ROUTE

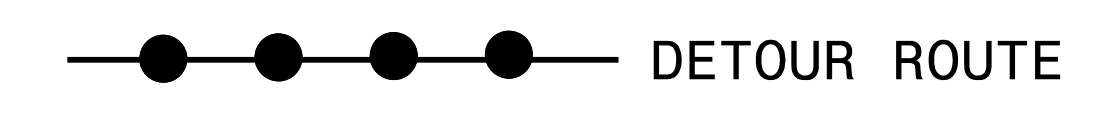

SEE SHEET TMP-2C FOR BARRICADE LEGEND
 SEE SHEET TMP-2AM FOR SPECIAL SIGN DESIGN DETAILS

REVISIONS

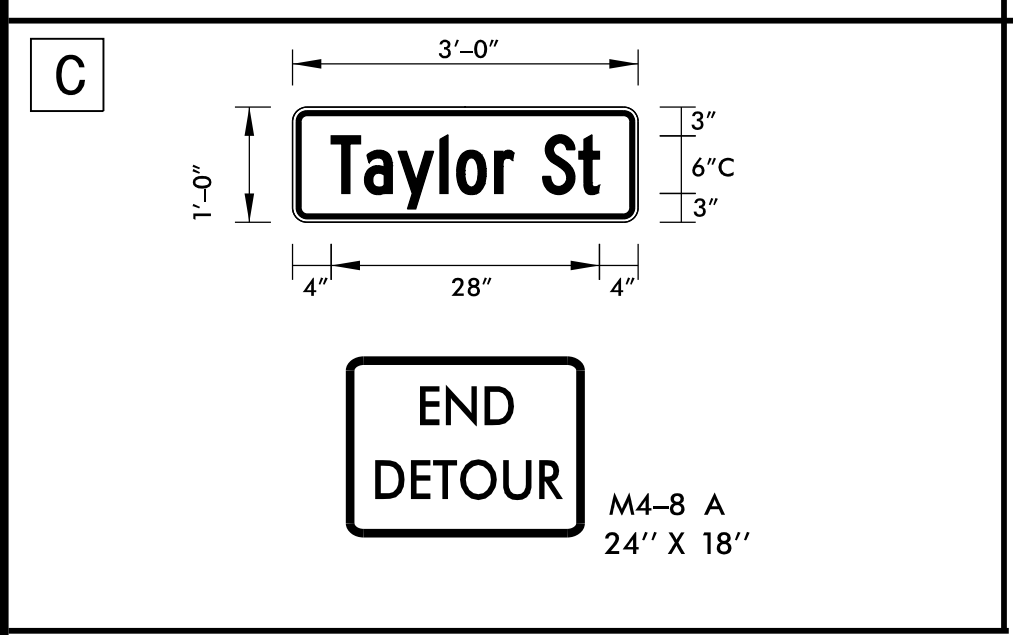
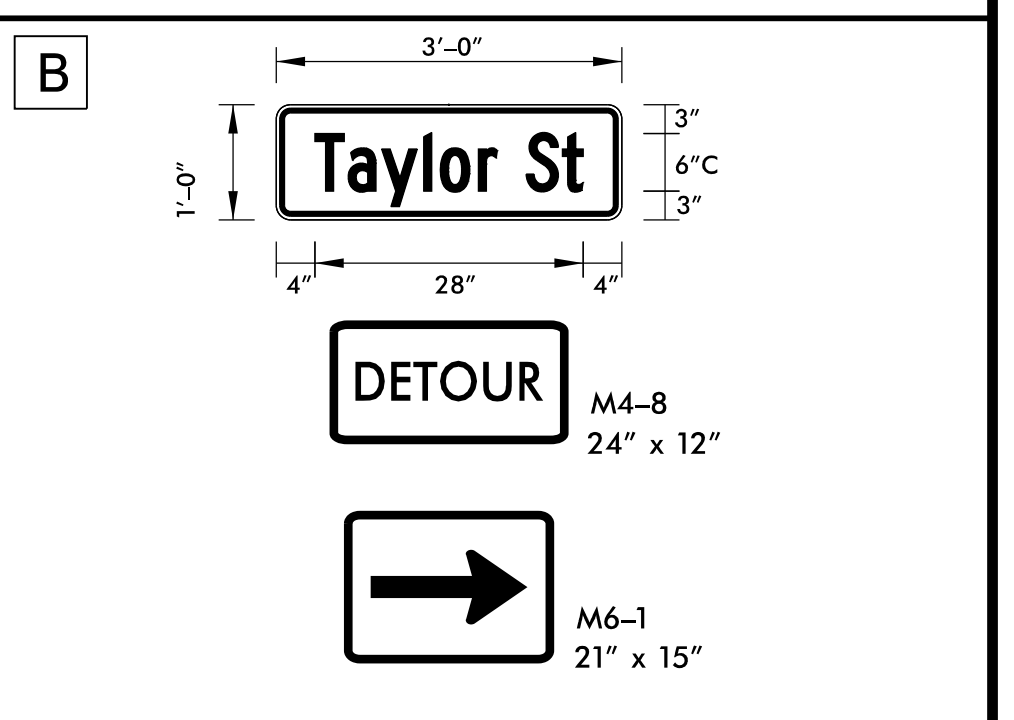
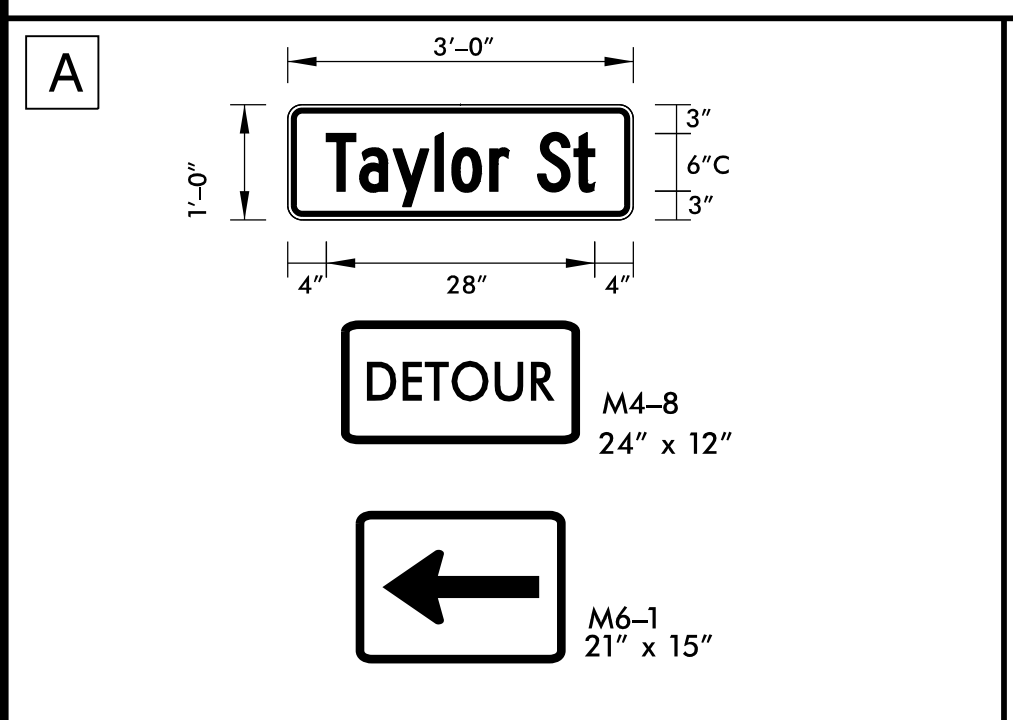
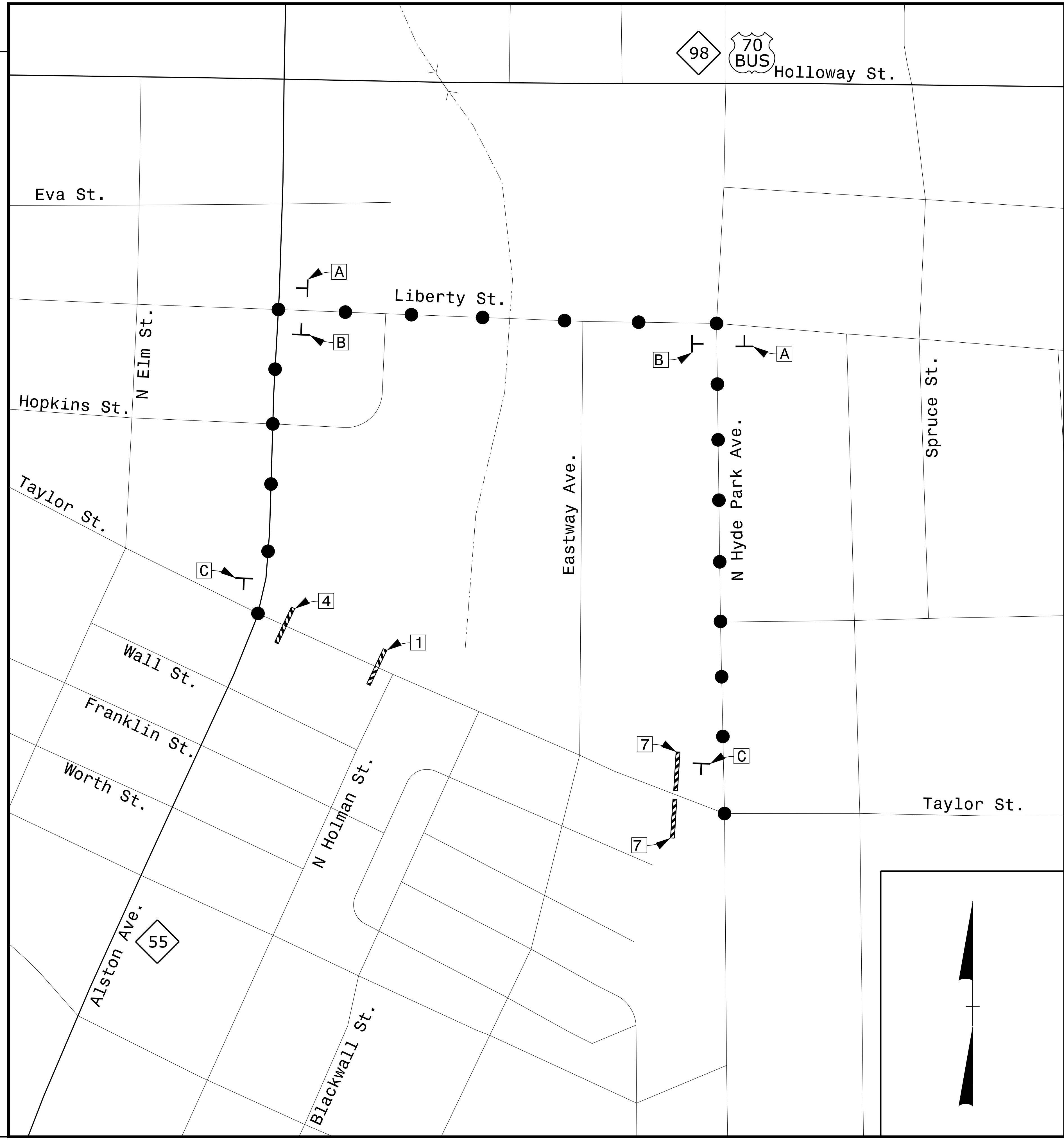

PLOT DRIVER: NCDOT_color_eng_50.plt
 USER: erbrooks
 DATE: 5/13/2016
 TIME: 10:40:38 AM
 FILE: c:\pwworking\tpa\d048729\U-3308_TMP_02C thru 02AB.dgn

**DOCUMENT NOT CONSIDERED FINAL
 UNLESS ALL SIGNATURES COMPLETED**

APPROVED:  DATE: 5/13/2016

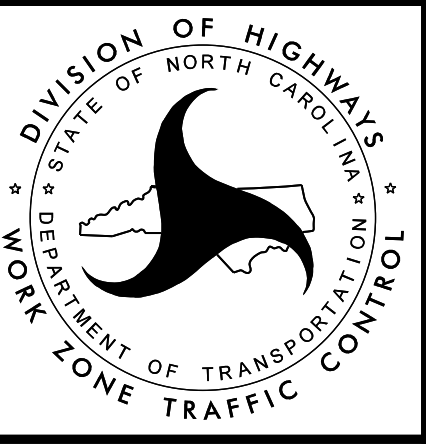

TAYLOR STREET
 DETOUR ROUTE

REVISIONS

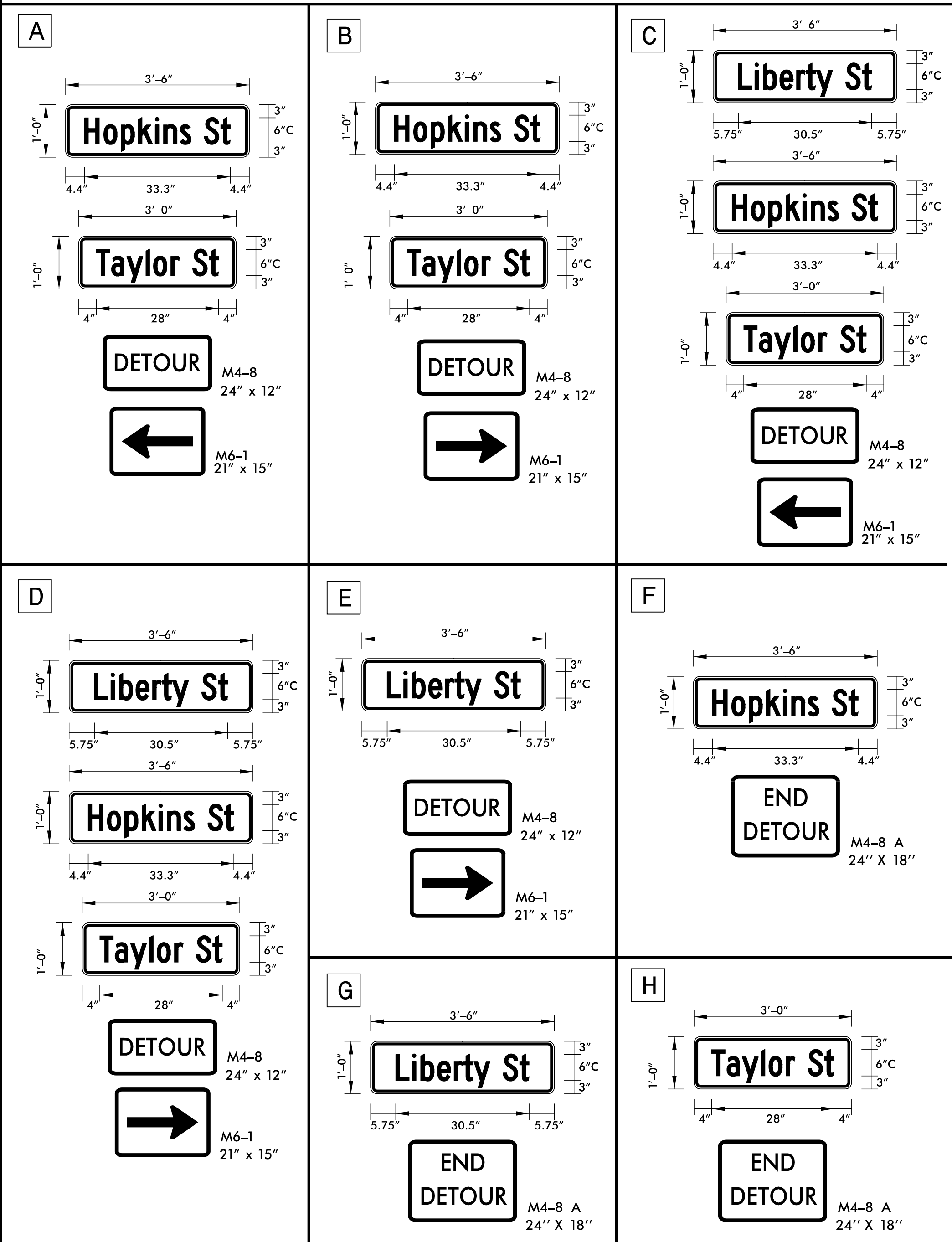
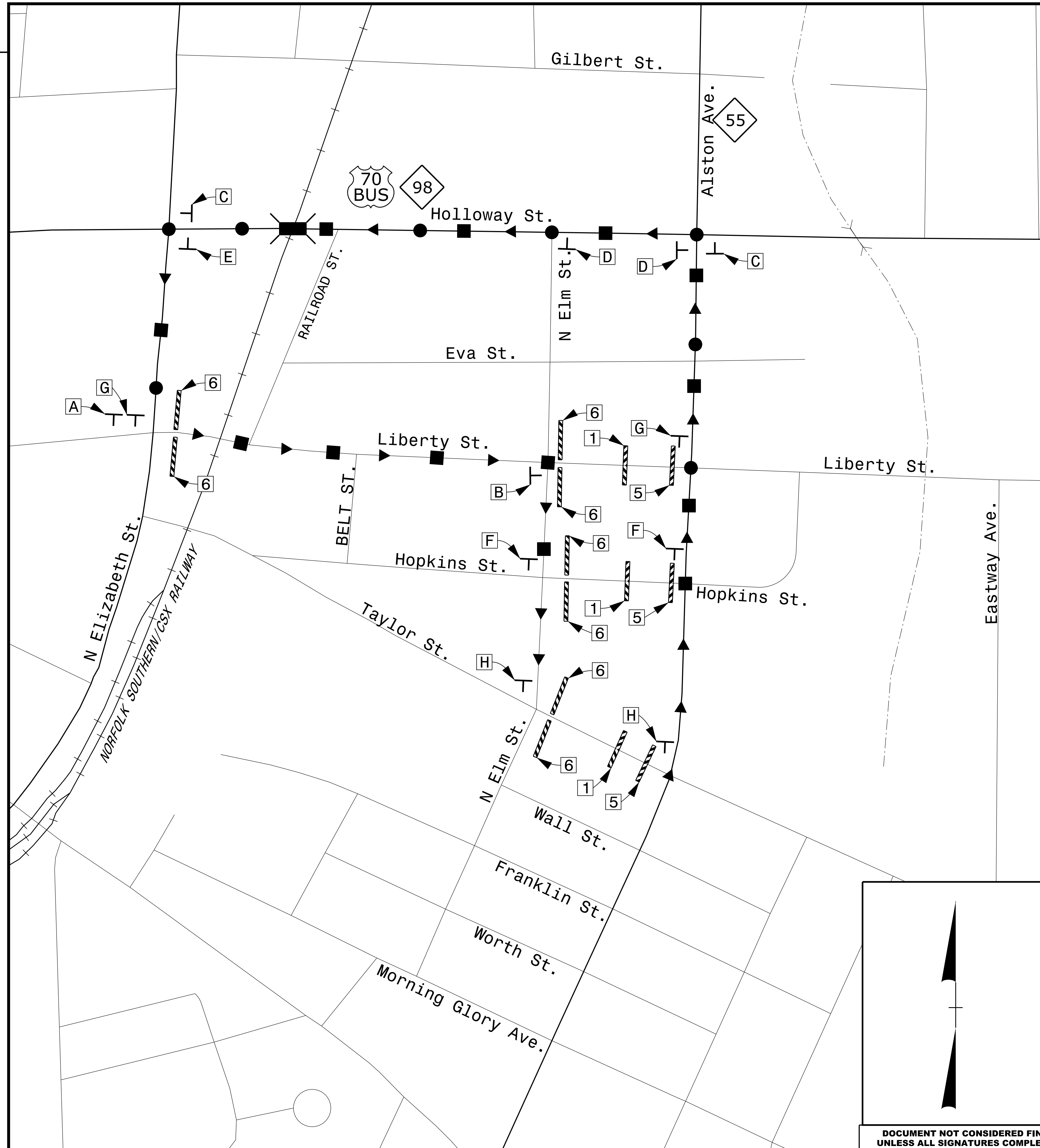

SEE SHEET TMP-2C FOR BARRICADE LEGEND
 SEE SHEET TMP-2AH, TMP-2AI & TMP-2AM FOR SPECIAL SIGN DESIGN DETAILS

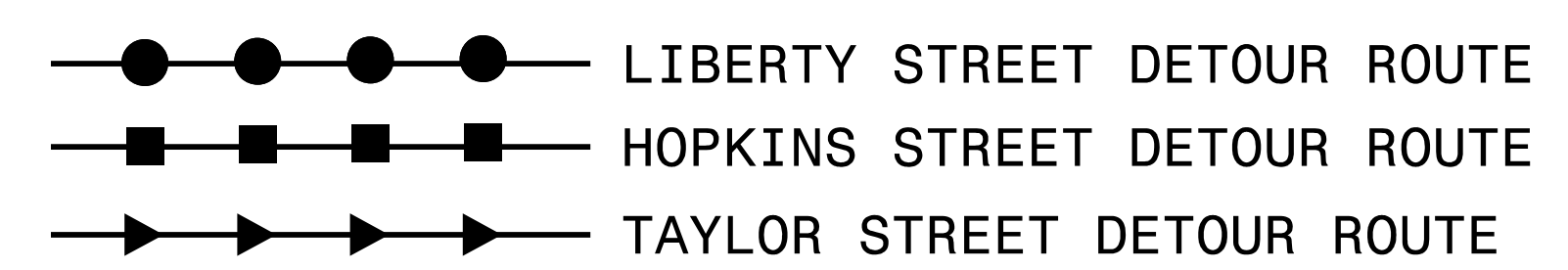

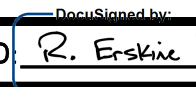
APPROVED  DATE: 5/13/2016

SEAL 

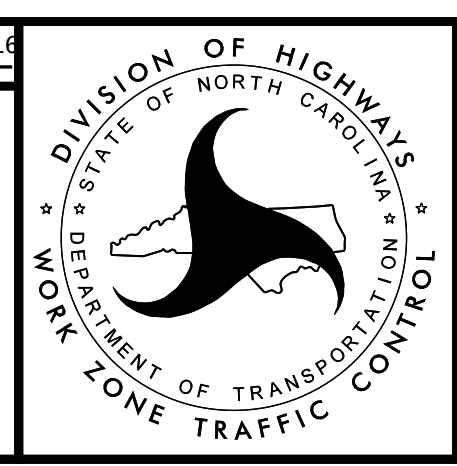

LIBERTY STREET
 HOPKINS STREET
 TAYLOR STREET
 DETOUR ROUTE

DOCUMENT NOT CONSIDERED FINAL
 UNLESS ALL SIGNATURES COMPLETED

PLOT DRIVER: NCDOT_pdf_color_eng_50.pit
 USER: erbrooks
 DATE: 5/13/2016
 TIME: 10:40:40 AM
 FILE: c:\pwworking\tpa\d0487729\U-3308_TMP-02C.thru 02AB.dgn

PENTABLE: NCDOT_tcp.tbl
 DATE: 5/13/2016
 TIME: 10:40:40 AM

REVISIONS

PLOT DRIVER: NCDOT_pdf_color_eng_50.plt
 USER: erbrooks
 DATE: 5/13/2016
 TIME: 10:40:42 AM
 FILE: c:\pwworking\tpa\0487729\U-3308_TMP-02C thru 02AB.dgn

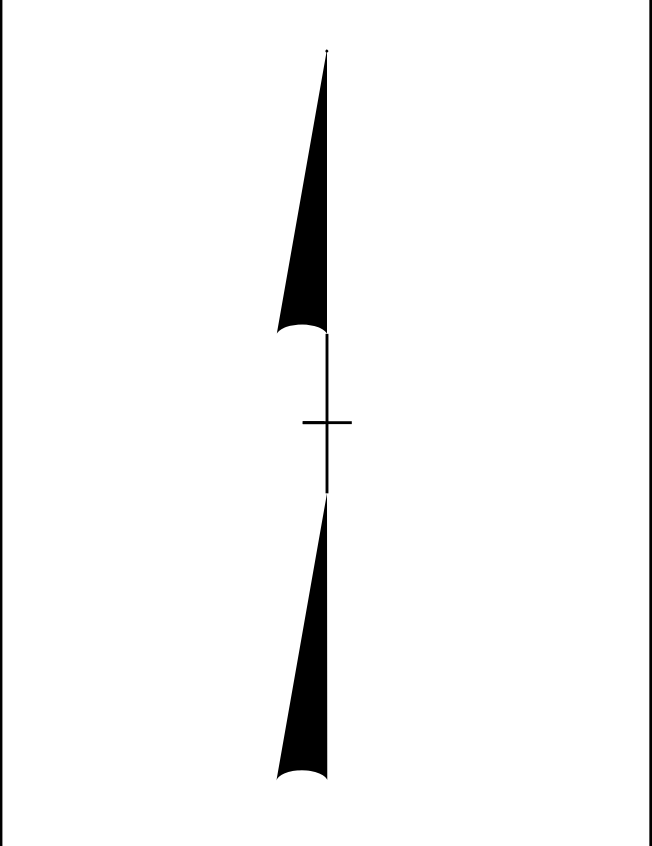
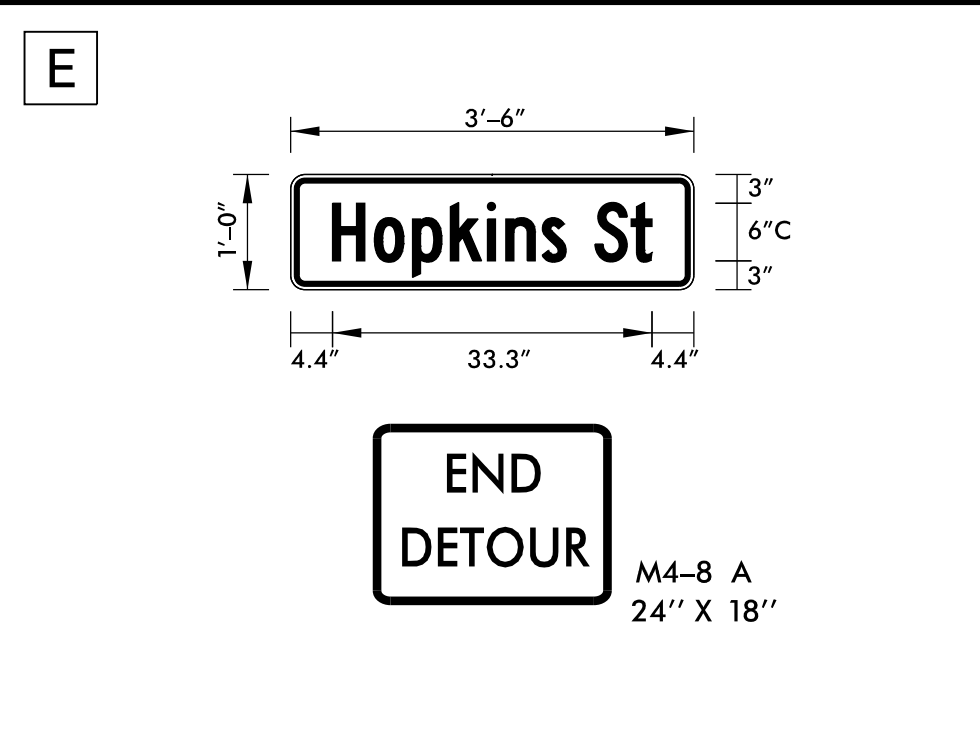
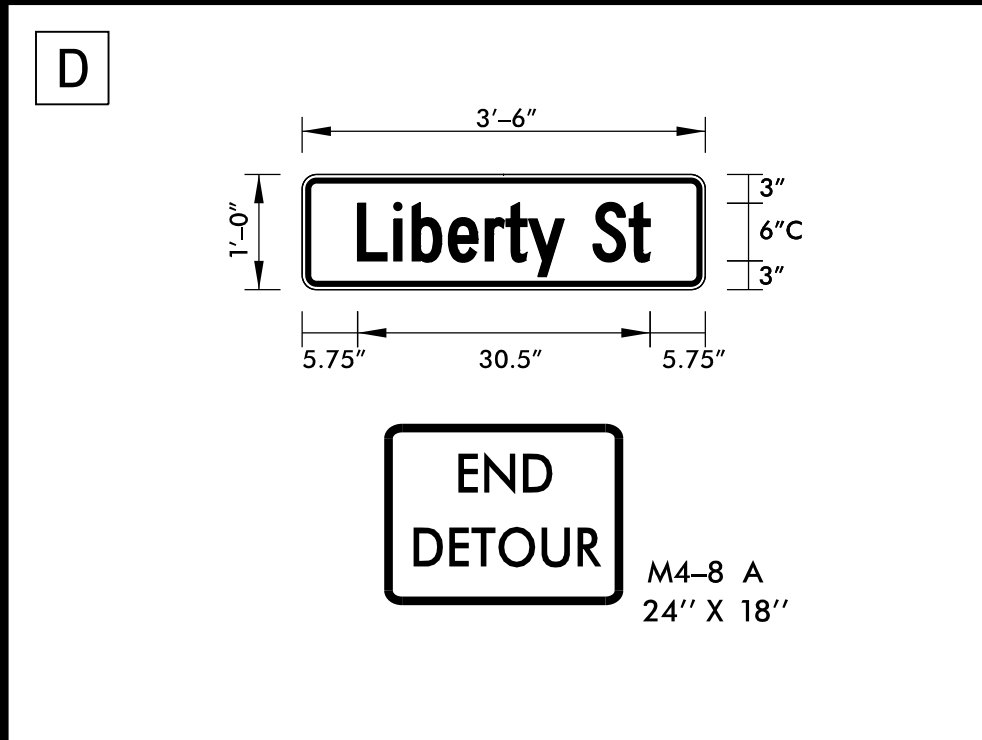
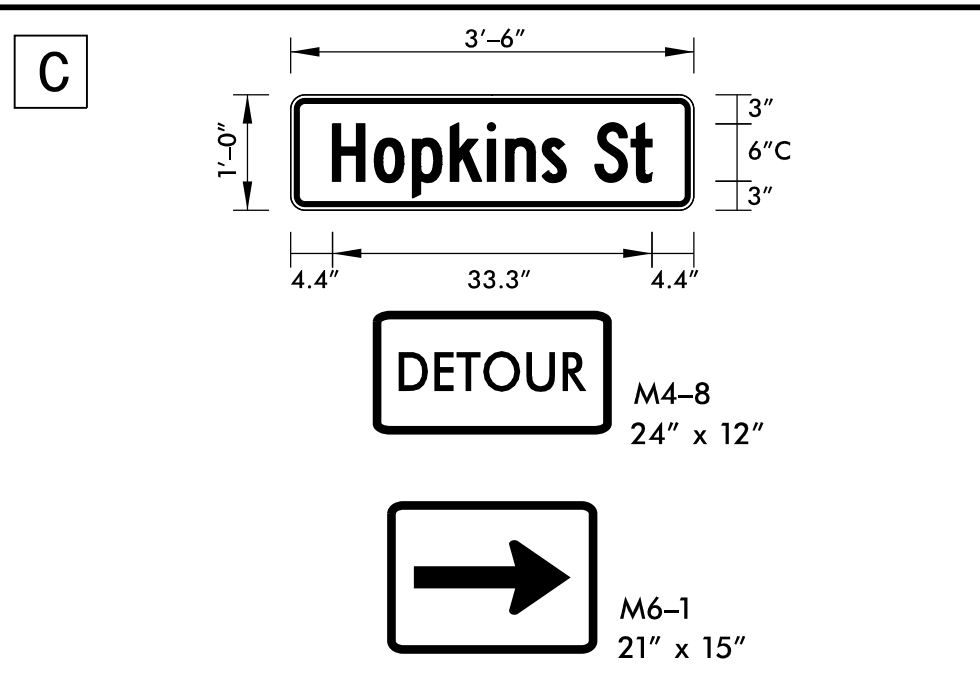
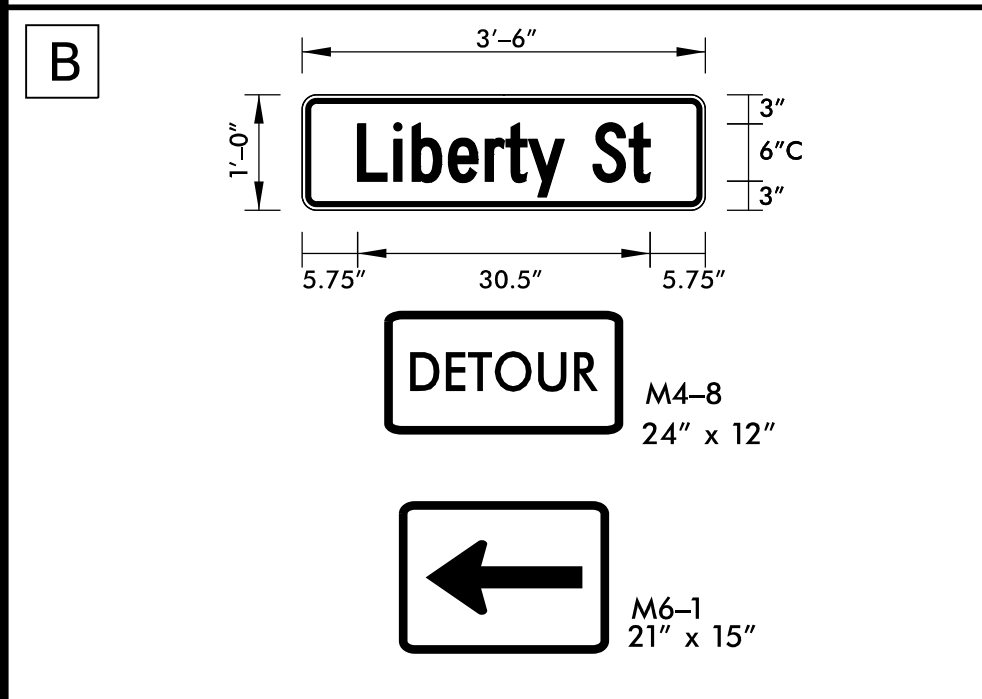
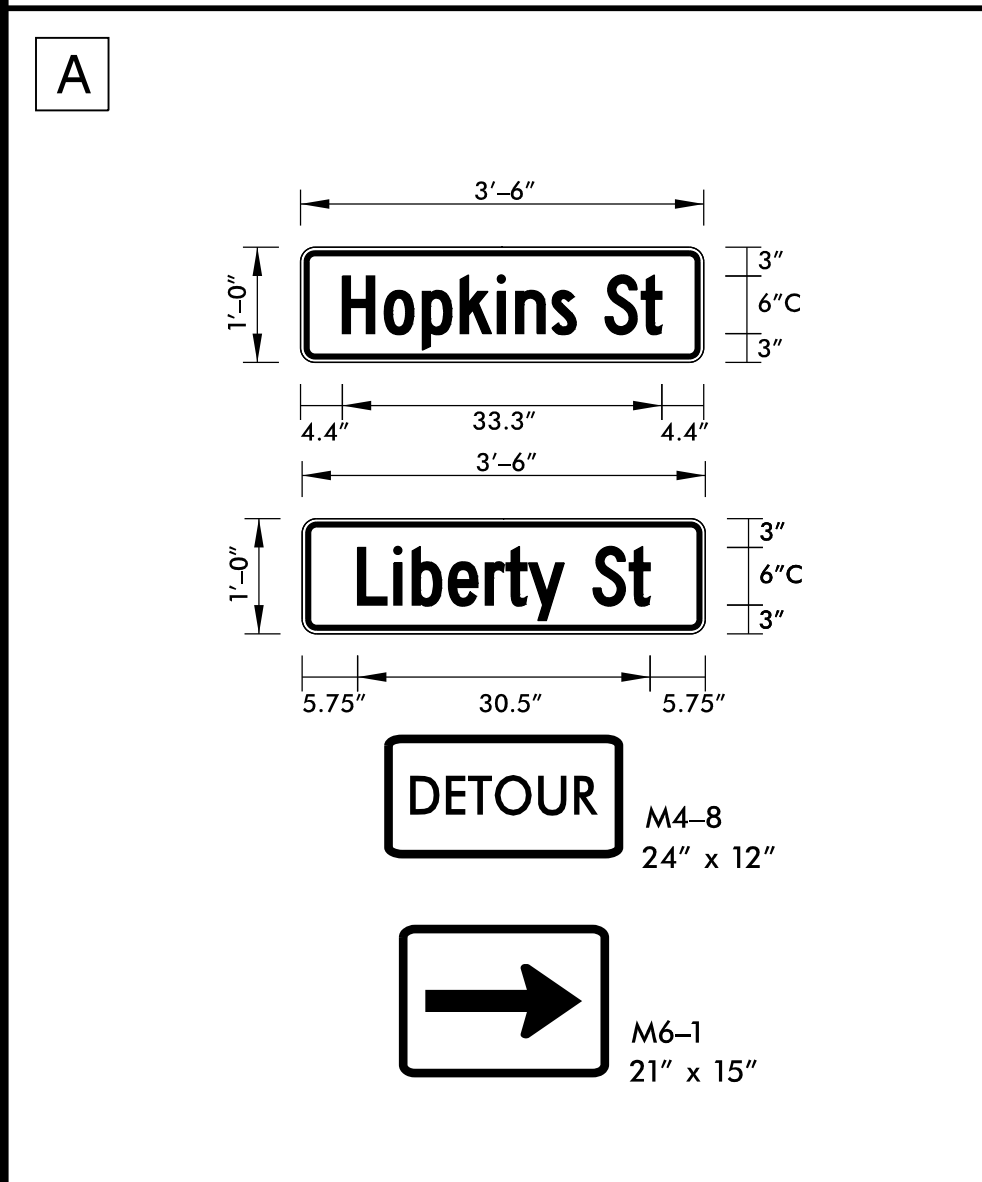
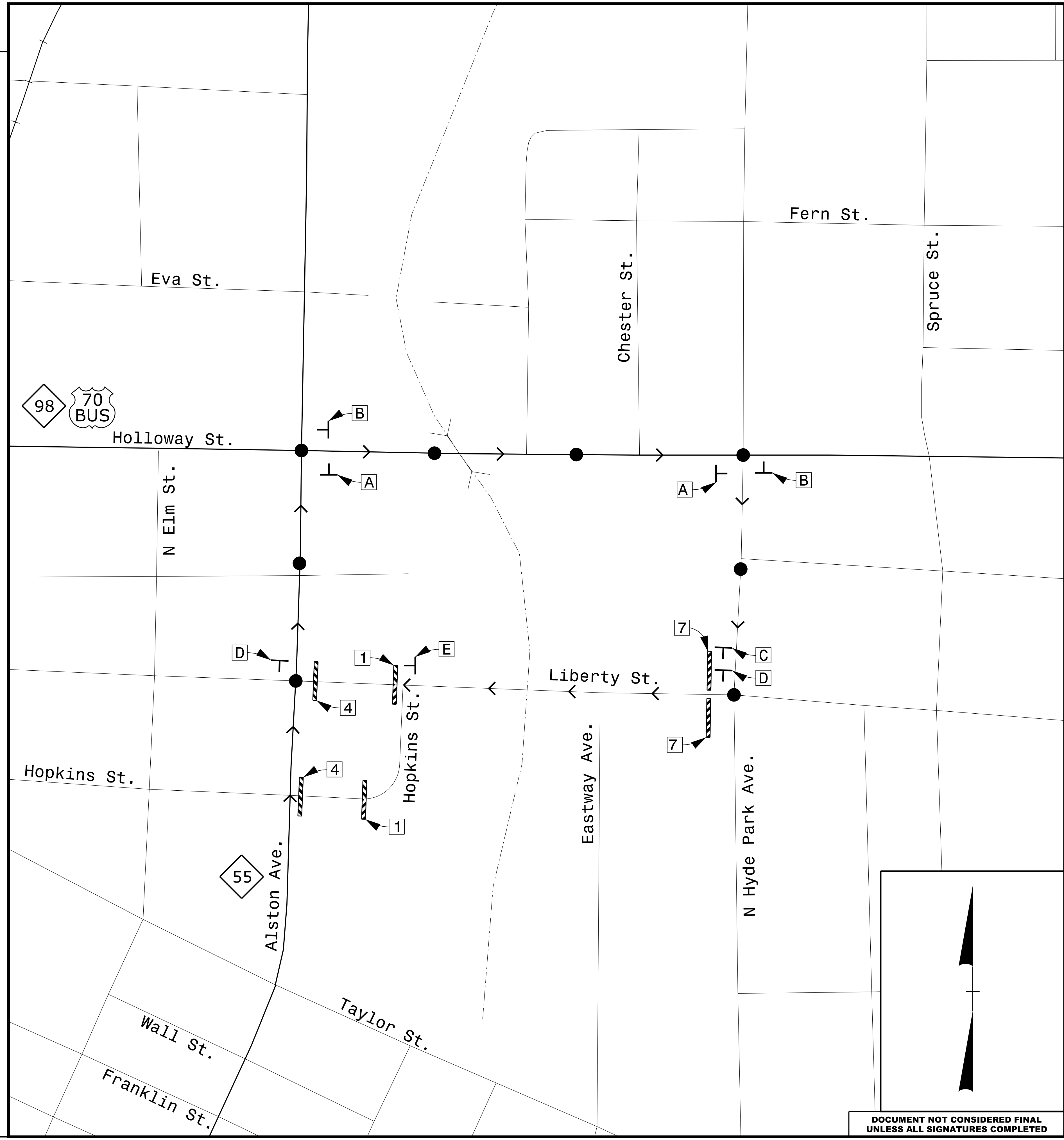

SEE SHEET TMP-2C FOR BARRICADE LEGEND
 SEE SHEET TMP-2AH & TMP-2AI FOR SPECIAL SIGN DESIGN DETAILS

●●●● LIBERTY STREET DETOUR ROUTE
 →→→→ HOPKINS STREET DETOUR ROUTE

APPROVED  DATE: 5/13/2016

SEAL



LIBERTY STREET
 HOPKINS STREET
 DETOUR ROUTE

DOCUMENT NOT CONSIDERED FINAL
 UNLESS ALL SIGNATURES COMPLETED

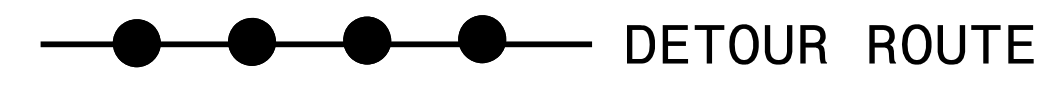

SEE SHEET TMP-2C FOR BARRICADE LEGEND
 SEE SHEET TMP-2AG FOR SPECIAL SIGN DESIGN DETAILS

REVISIONS

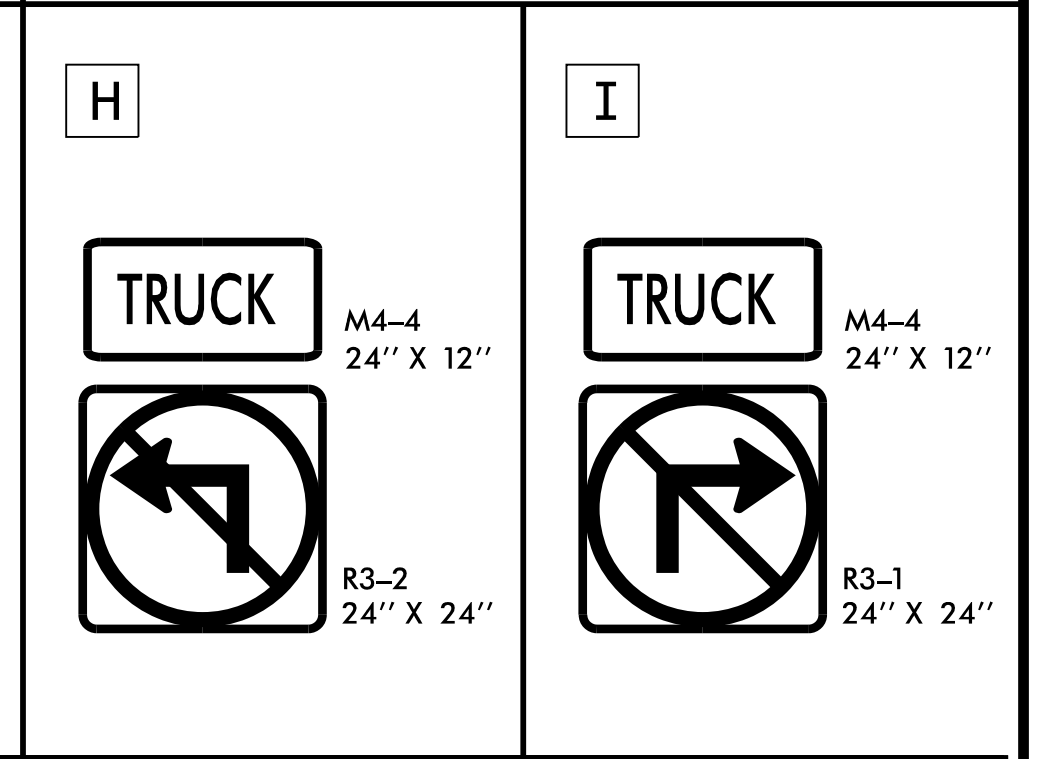
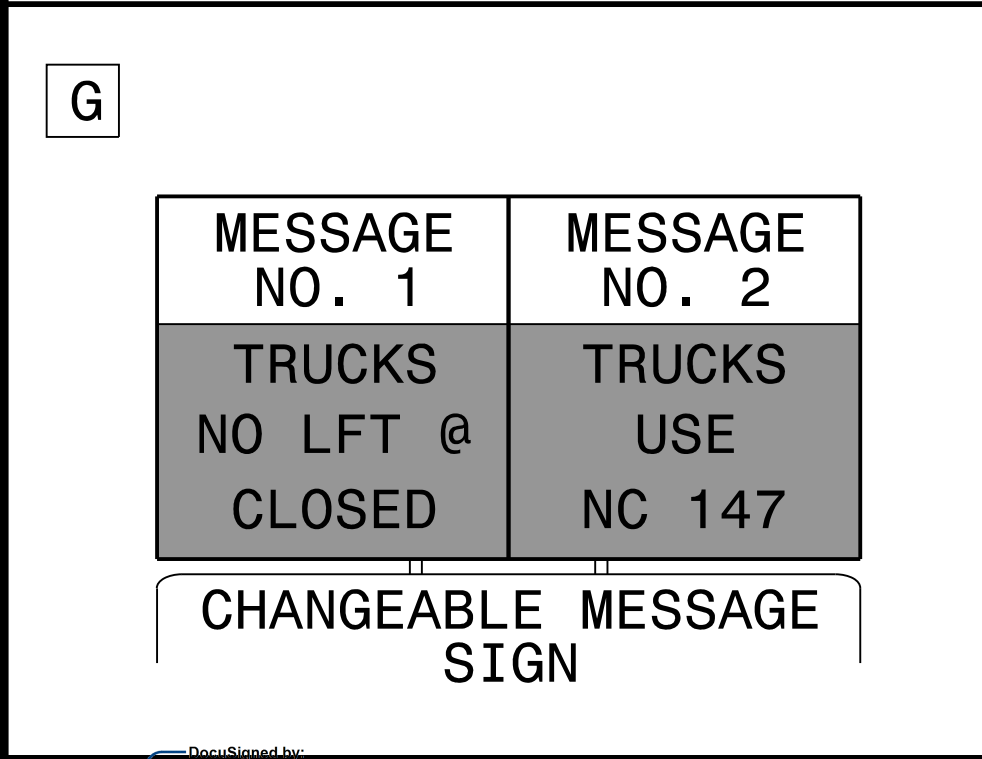
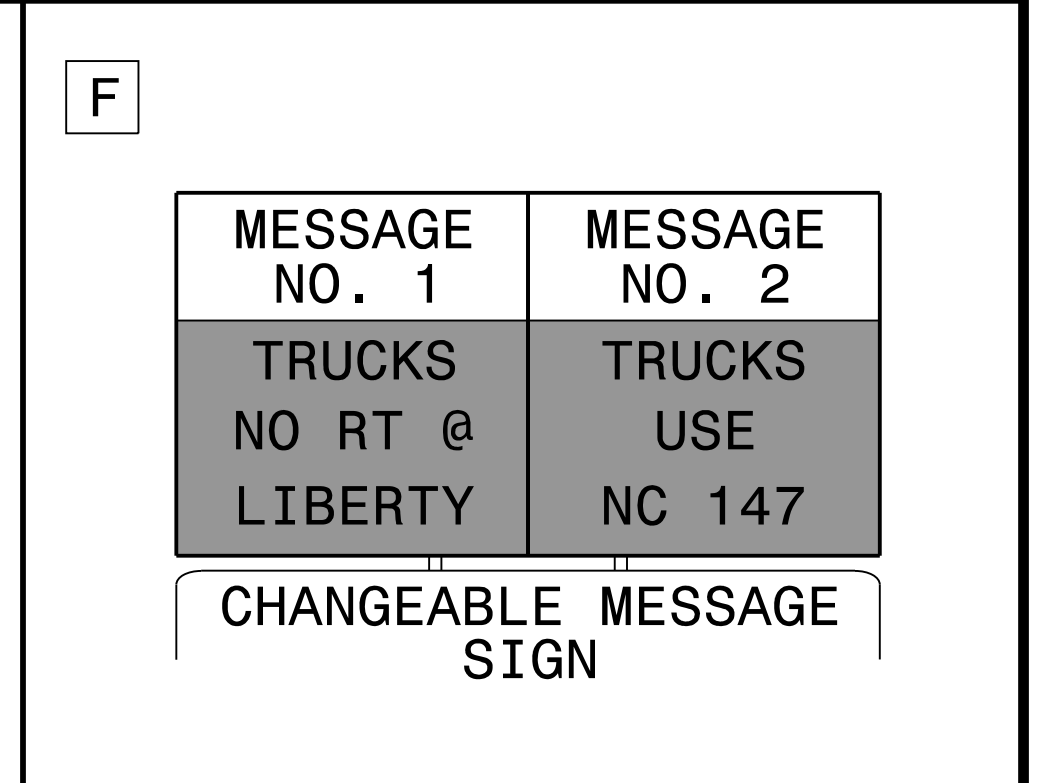
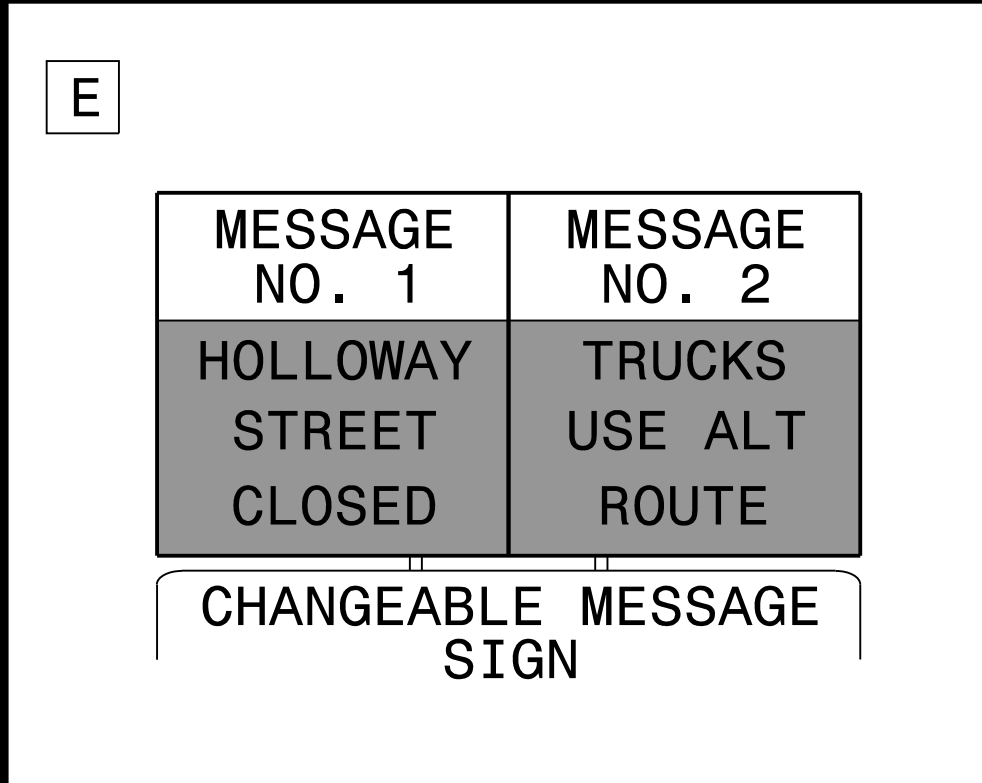
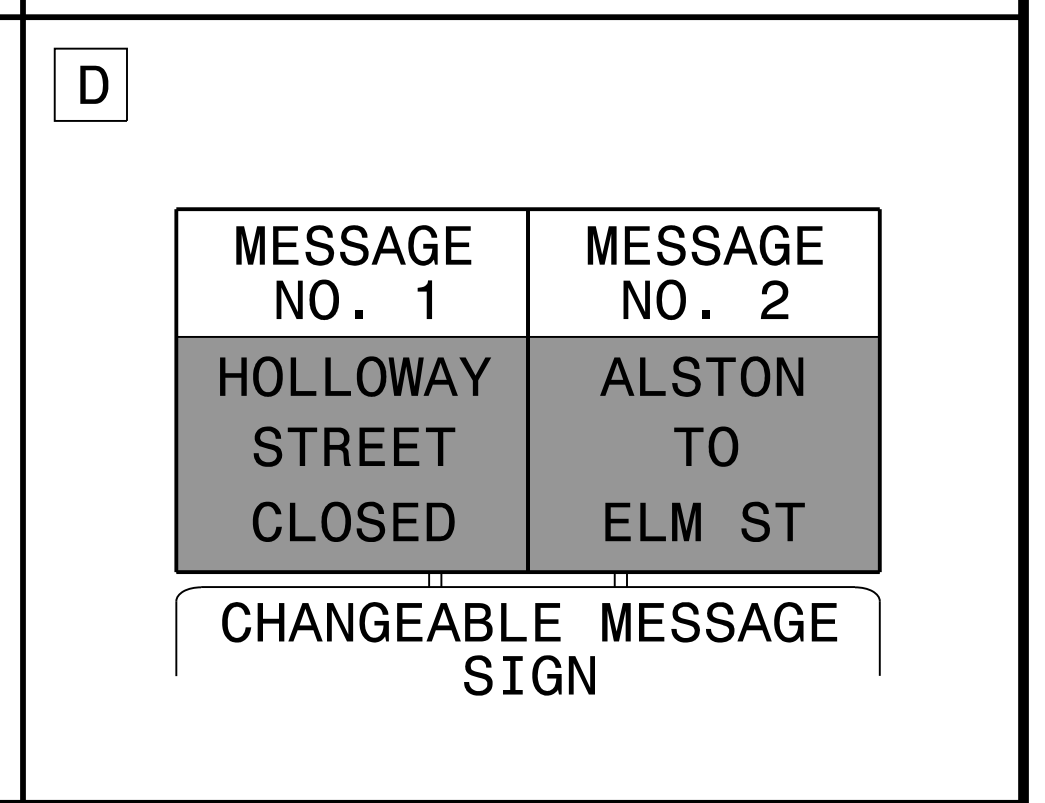
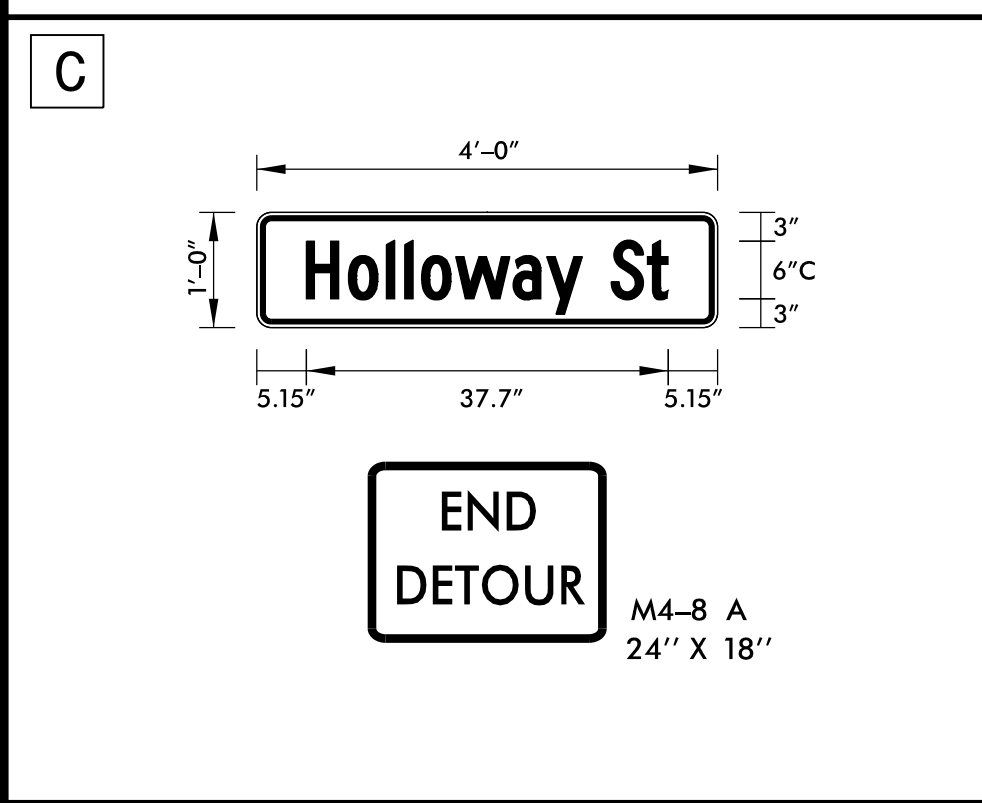
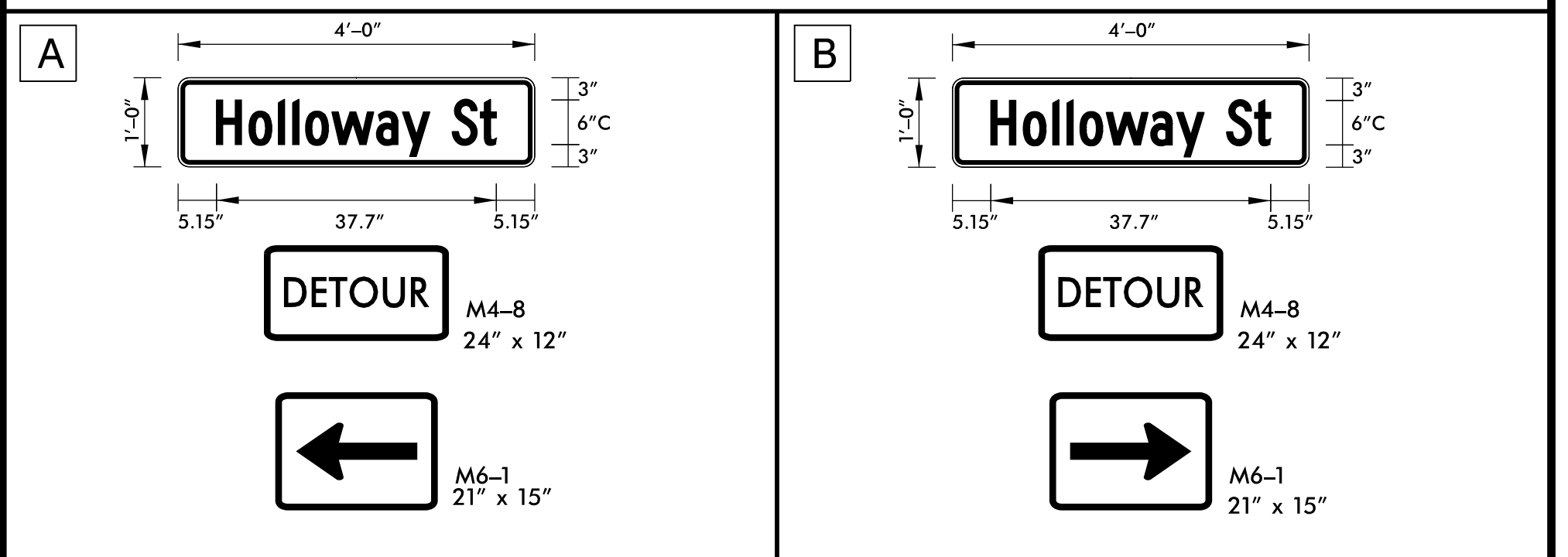
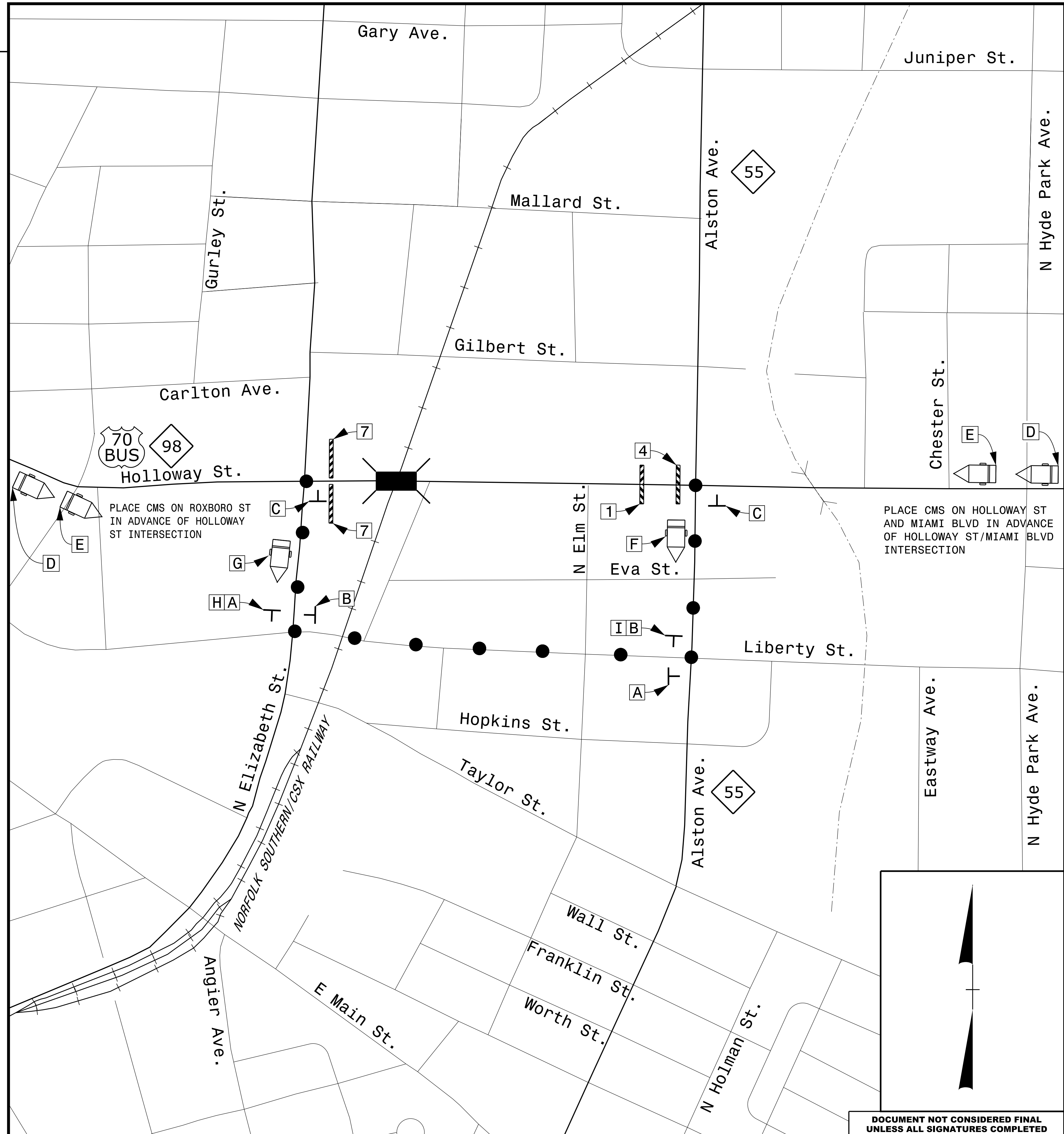

APPROVED  DATE: 5/13/2016

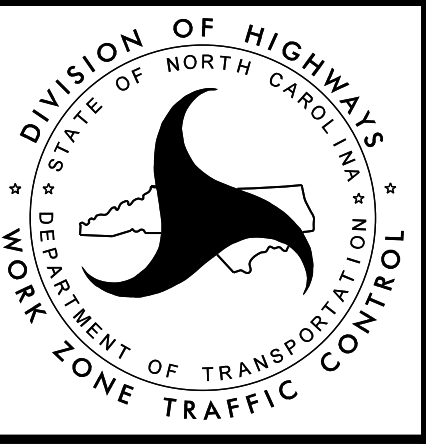

HOLLOWAY STREET
 (US 70 BUS / NC 98)
 DETOUR ROUTE

DOCUMENT NOT CONSIDERED FINAL
 UNLESS ALL SIGNATURES COMPLETED

PLOT DRIVER: NCDOT_pdf_color_eng_50.pit
 USER: erbrooks
 DATE: 5/13/2016
 TIME: 10:40:44 AM
 FILE: c:\pwworking\tpa\d048729\U-3308_TMP-02C thru 02AB.dgn

●●●● DETOUR ROUTE

SEE SHEET TMP-2AG FOR SPECIAL SIGN DESIGN DETAILS

MESSAGE NO. 1 ALSTON NO LFT @ HOLLOWAY	MESSAGE NO. 2 TRUCKS USE ALT ROUTE
CHANGEABLE MESSAGE SIGN	

MESSAGE NO. 1 NO LEFT TURNS AT HOLLOWAY	MESSAGE NO. 2 FOLLOW DETOUR
CHANGEABLE MESSAGE SIGN	

MESSAGE NO. 1 NO LEFT TURNS AT HOLLOWAY	MESSAGE NO. 2 TRUCKS USE ALT ROUTE
CHANGEABLE MESSAGE SIGN	

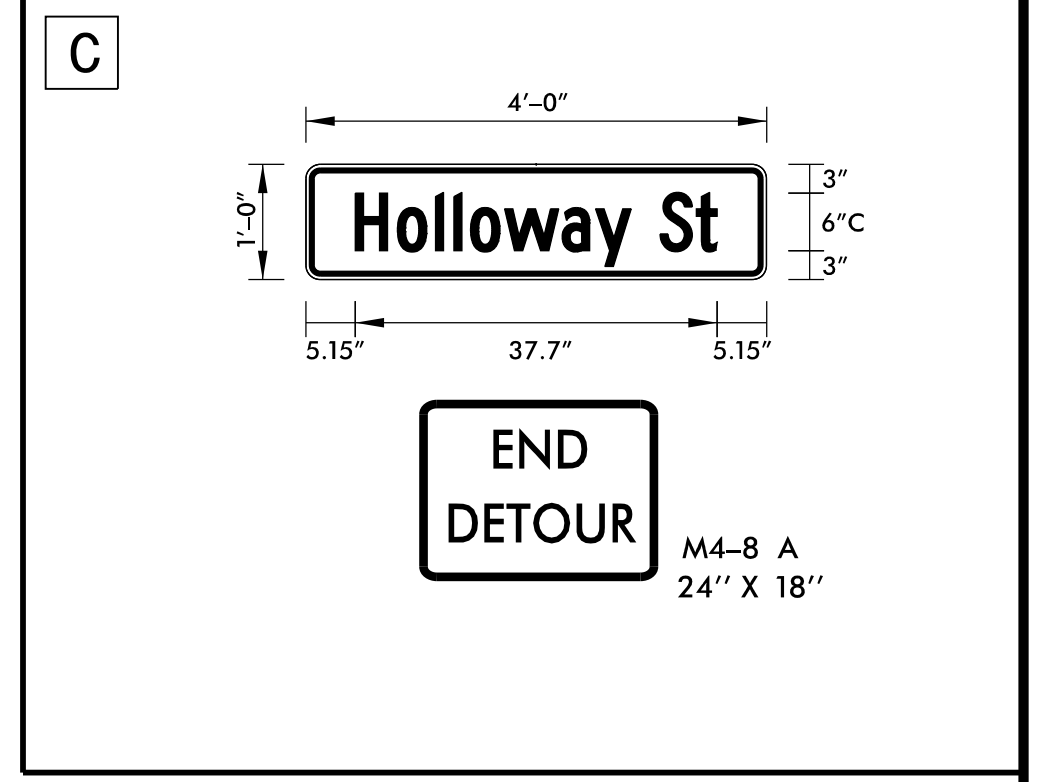
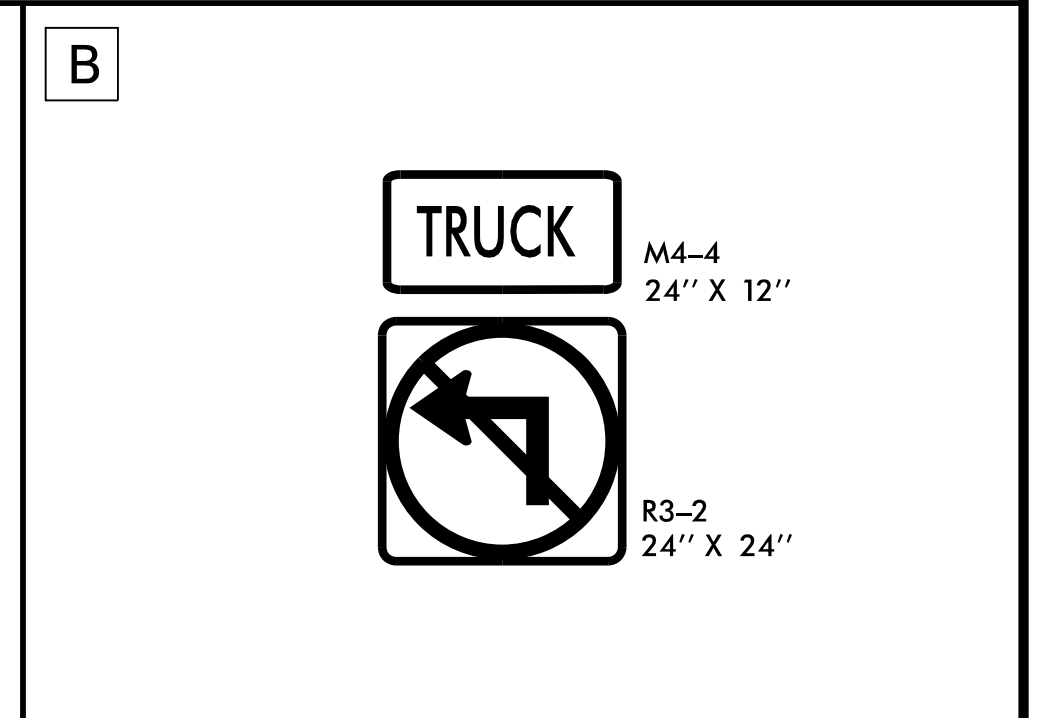
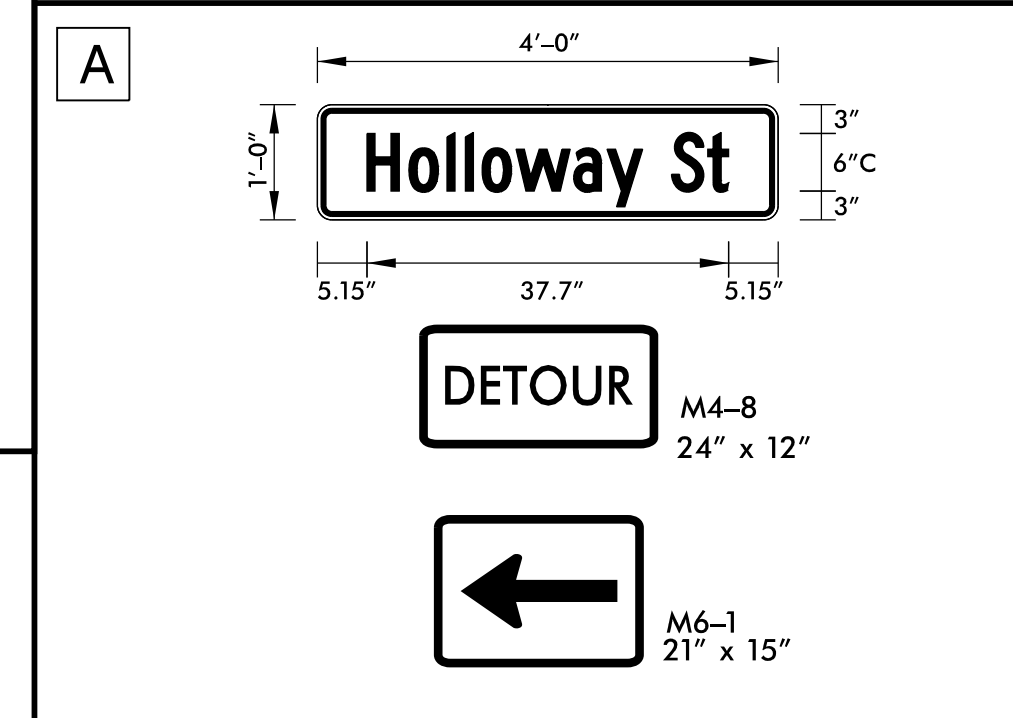

REVISIONS

PLOT DRIVER: NCDOT_pdf_color_eng_50.pit
 USER: erbrooks
 DATE: 5/12/2016
 TIME: 3:57:48 PM
 FILE: c:\pwworking\tpa\048729\U-3308_TMP-TMP-02C thru 02AB.dgn

APPROVED  DATE: 5/13/2016

SEAL 

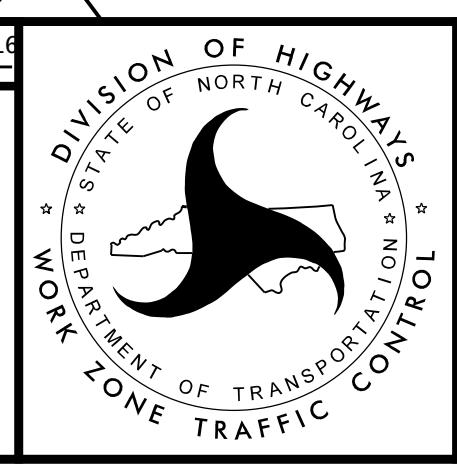

NC 55 SB LEFT TURN TO
 HOLLOWAY STREET
 (US 70 BUS / NC 98)
 DETOUR ROUTE

DOCUMENT NOT CONSIDERED FINAL UNLESS ALL SIGNATURES COMPLETED

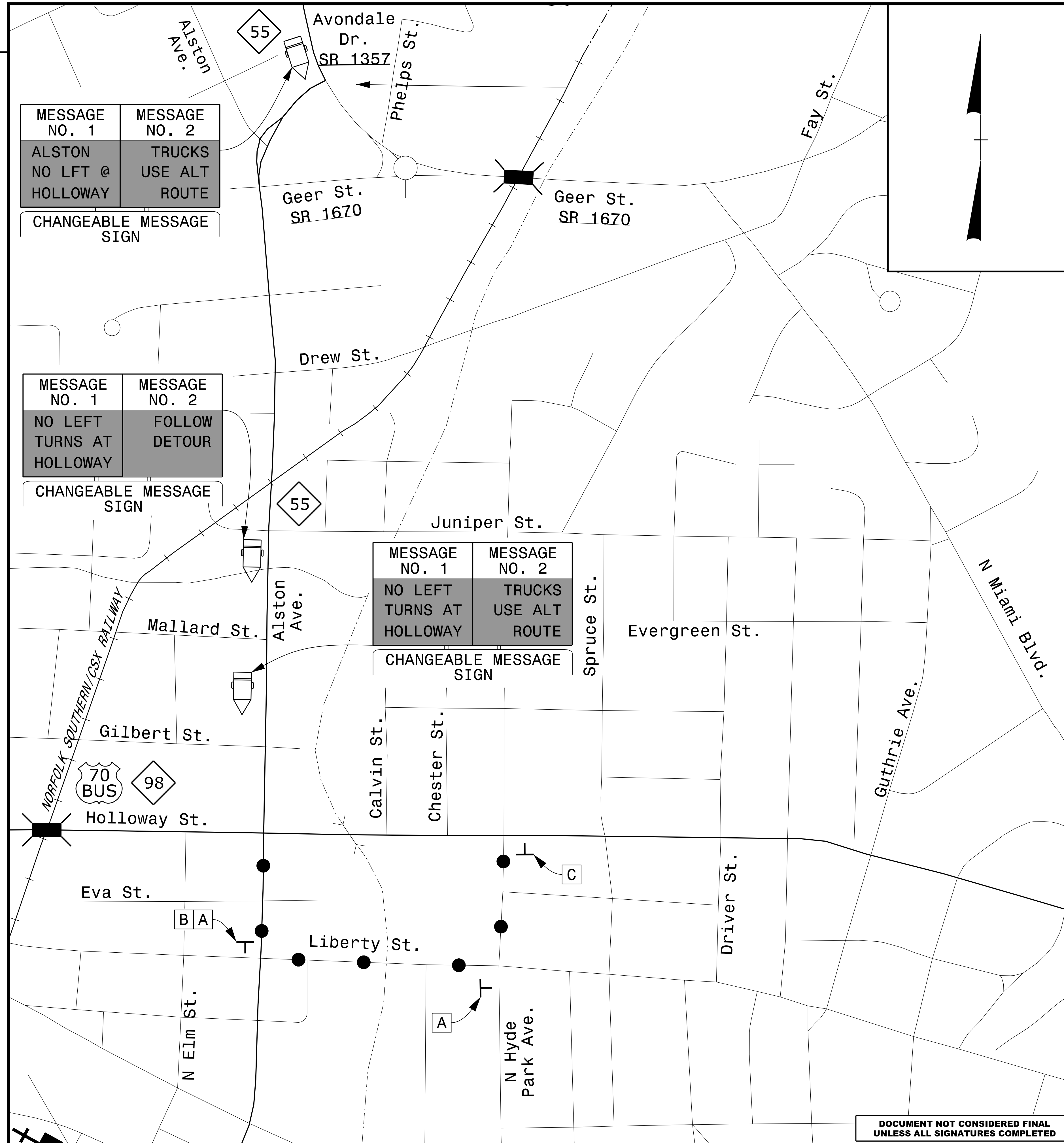

REVISIONS

PLOT DRIVER: NCDOT_pdf_color_eng_50.plt PENTABLE: NCDOT_tcp.tbl
 USER: erbrooks DATE: 5/12/2016 TIME: 3:57:50 PM
 FILE: c:\pwworking\tpa\048729\U-3308_TMP_02C.thru_02AB.dgn

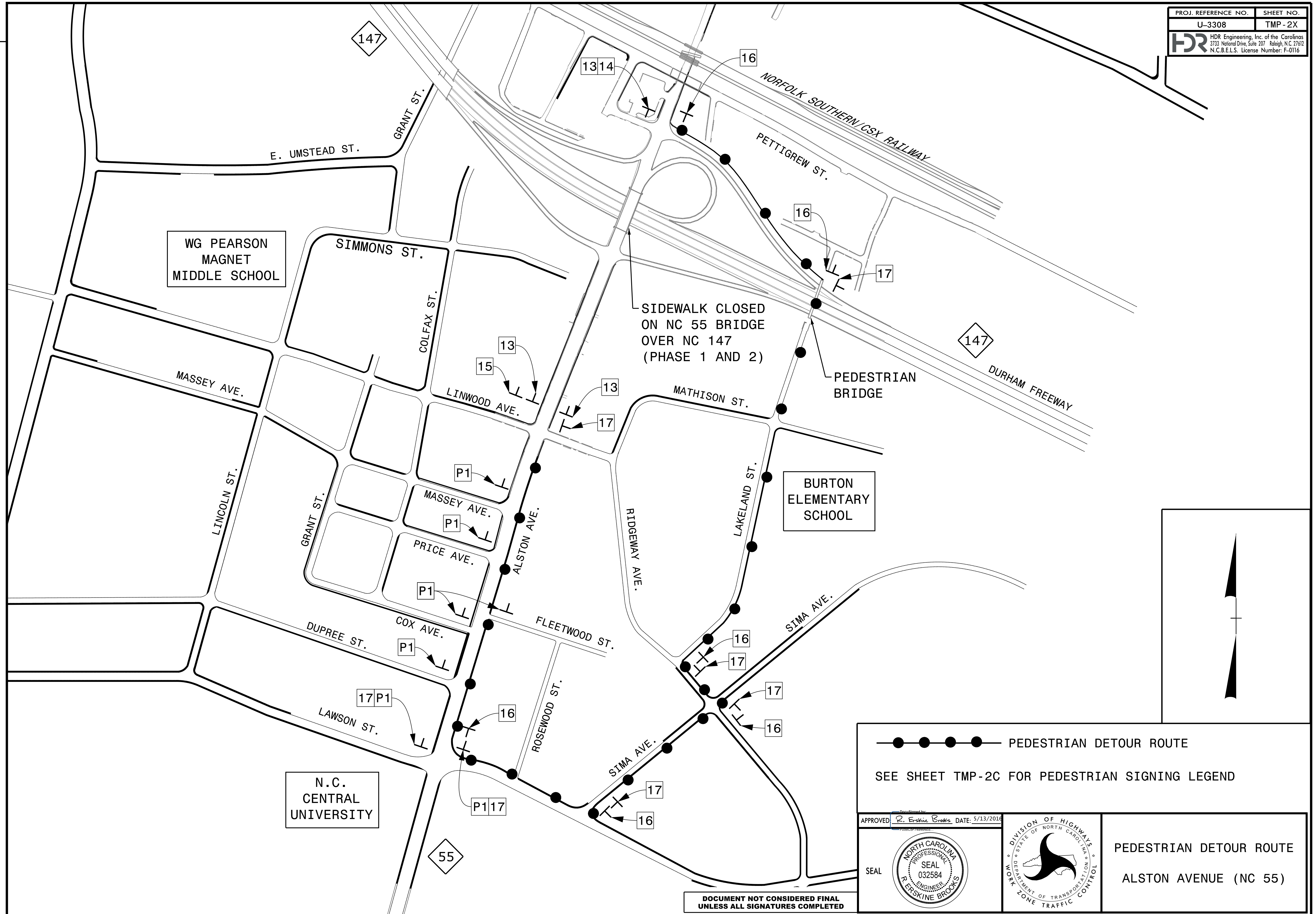

SIDEWALK CLOSED
 ON NC 55 BRIDGE
 OVER NC 147
 (PHASE 1 AND 2)

●●●● PEDESTRIAN DETOUR ROUTE
 SEE SHEET TMP-2C FOR PEDESTRIAN SIGNING LEGEND

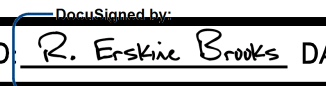
APPROVED  DATE: 5/13/2016

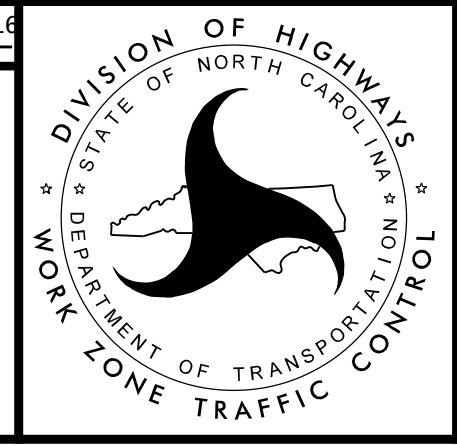
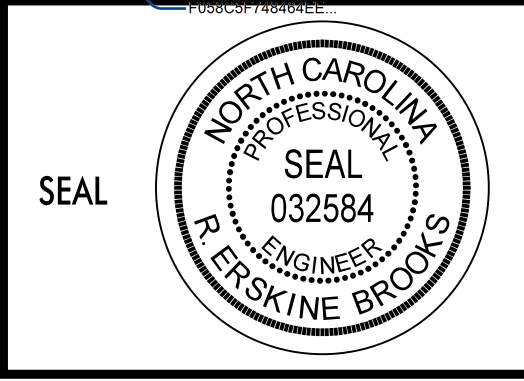

PEDESTRIAN DETOUR ROUTE
 ALSTON AVENUE (NC 55)

DOCUMENT NOT CONSIDERED FINAL
 UNLESS ALL SIGNATURES COMPLETED

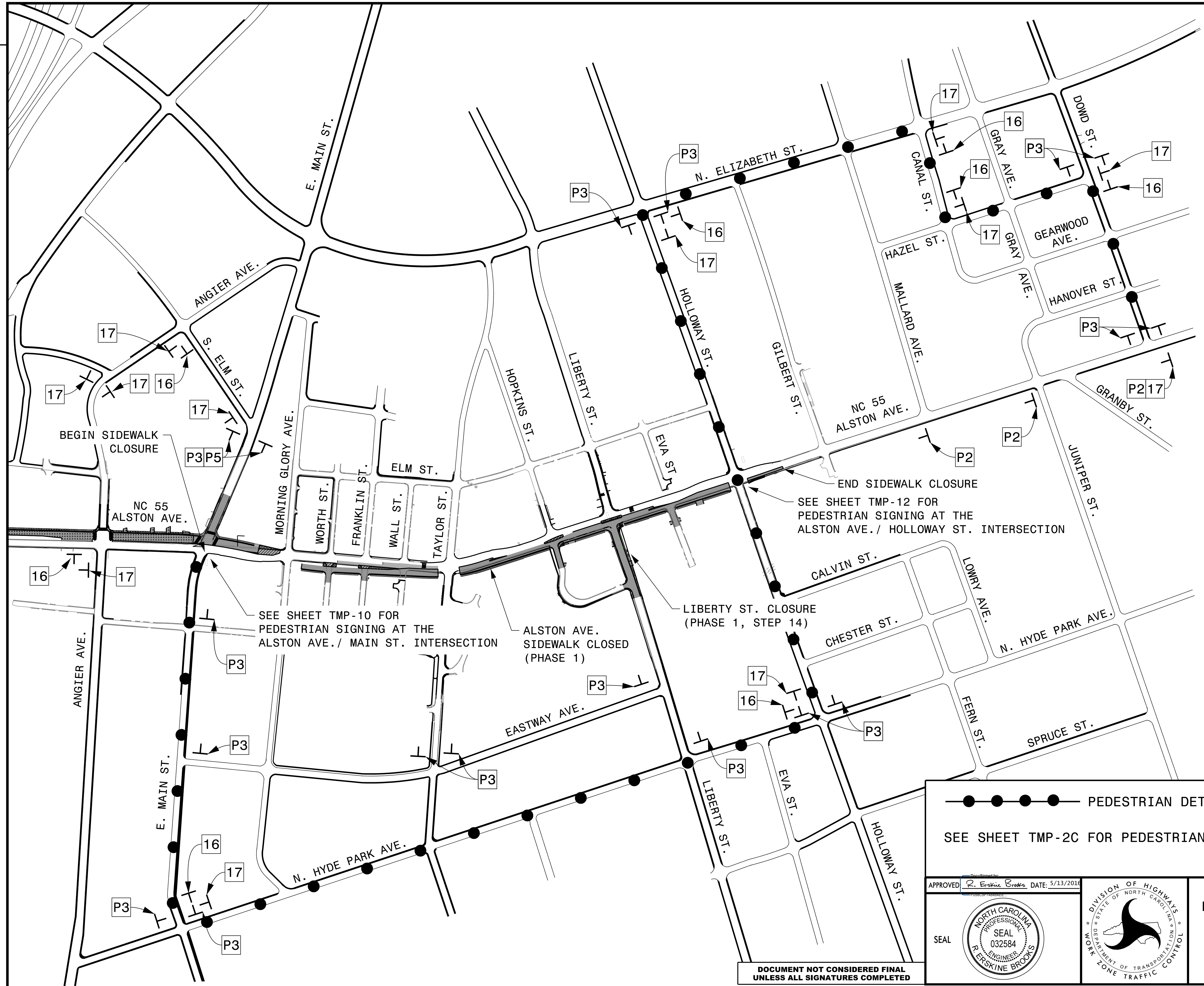

REVISIONS

BEGIN SIDEWALK CLOSURE

END SIDEWALK CLOSURE
SEE SHEET TMP-12 FOR PEDESTRIAN SIGNING AT THE ALSTON AVE./ HOLLOWAY ST. INTERSECTION

SEE SHEET TMP-10 FOR PEDESTRIAN SIGNING AT THE ALSTON AVE./ MAIN ST. INTERSECTION

ALSTON AVE. SIDEWALK CLOSED (PHASE 1)

LIBERTY ST. CLOSURE (PHASE 1, STEP 14)

●●●●● PEDESTRIAN DETOUR ROUTE
SEE SHEET TMP-2C FOR PEDESTRIAN SIGNING LEGEND

PLOT DRIVER: NCDOT_pdf_color_eng_50.plt
USER: erbrooks
FILE: c:\pwworking\tpa\d048729\U-3308\TMP-TMP-02C thru 02AB.dgn
PENTABLE: NCDOT_tcp.tbl
DATE: 5/12/2016
TIME: 3:57:52 PM

APPROVED  DATE: 5/13/2016

SEAL

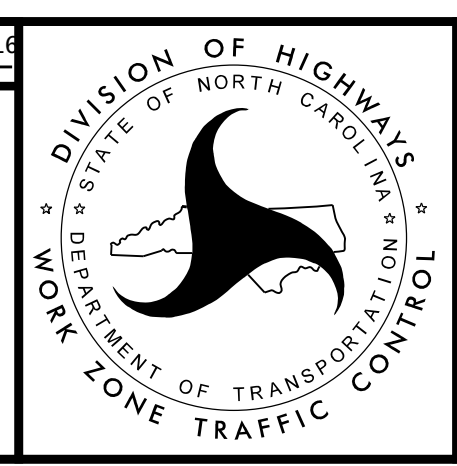

PEDESTRIAN DETOUR ROUTE
PHASE 1
STEPS 11-14 & 17-21

DOCUMENT NOT CONSIDERED FINAL
UNLESS ALL SIGNATURES COMPLETED

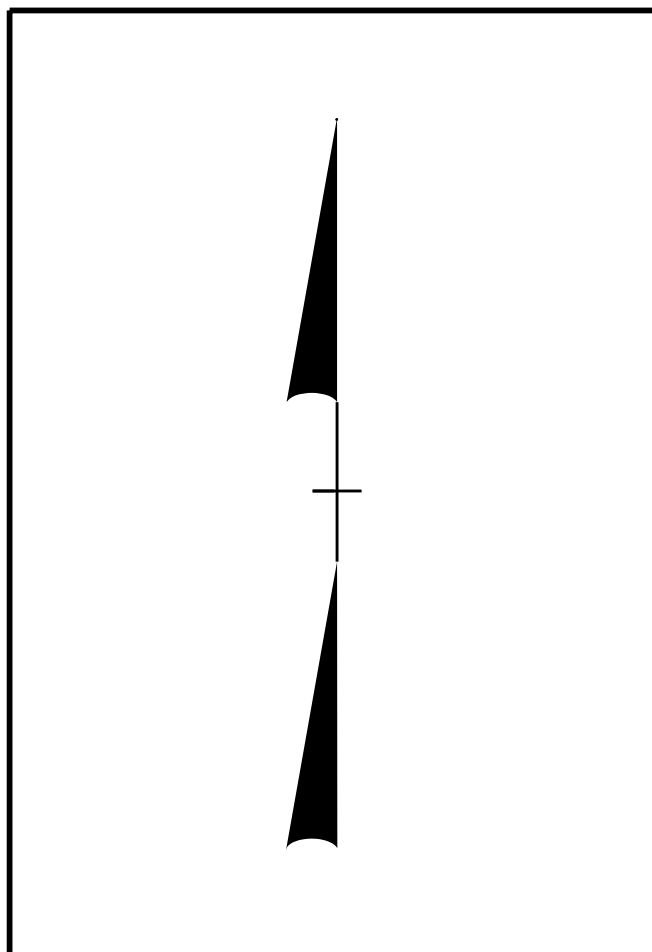

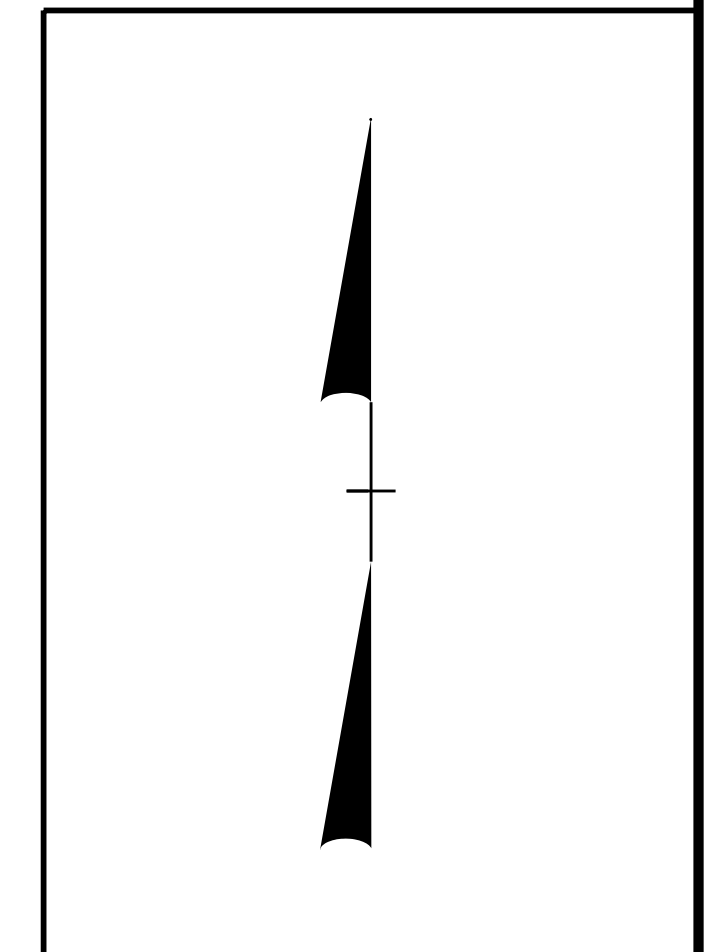
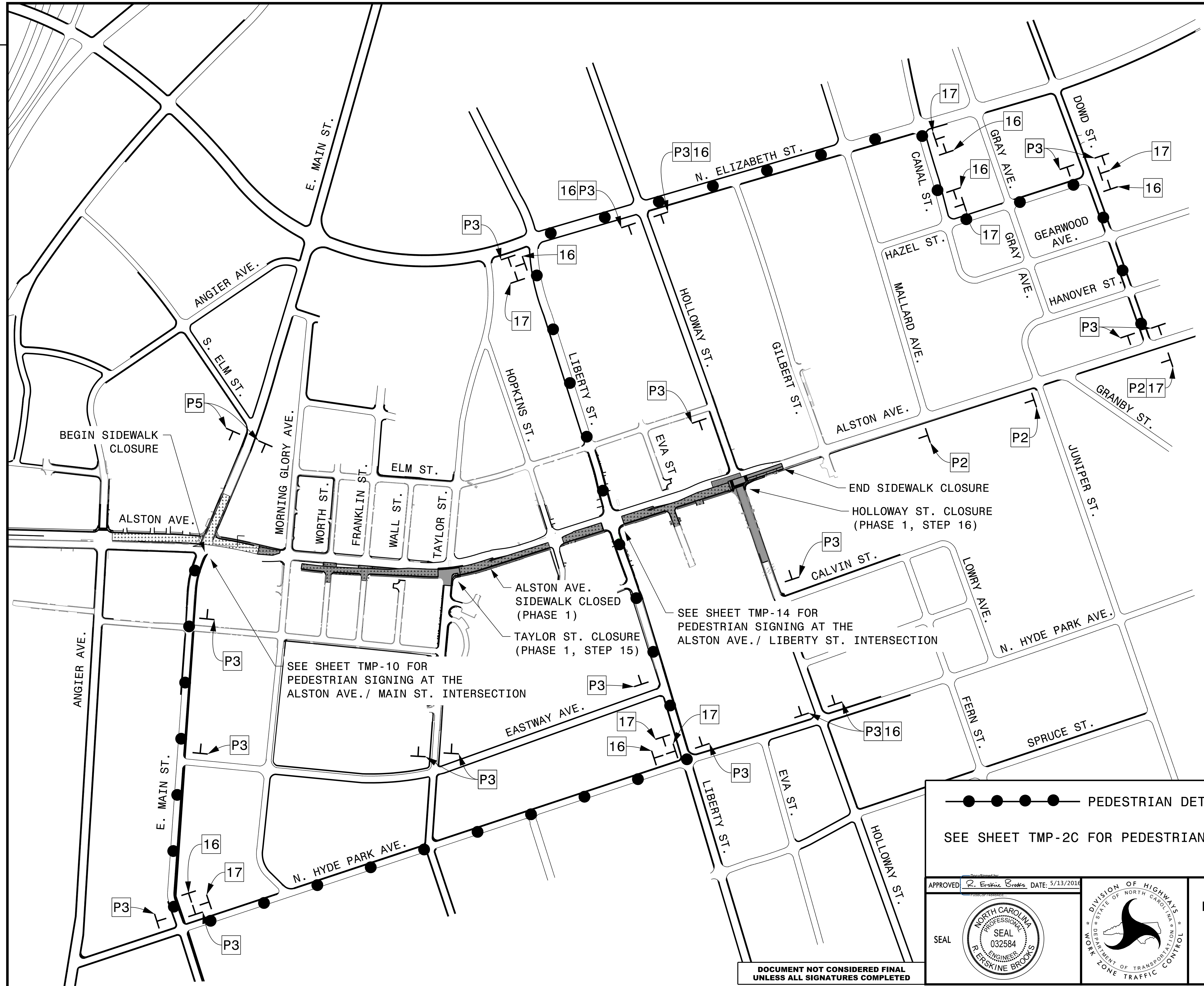

REVISIONS

PLOT DRIVER: NCDOT_pdf_color_eng_50.ppt
 USER: erbrooks
 DATE: 5/12/2016
 TIME: 3:57:54 PM
 FILE: c:\pwworking\tpa\d048729\U-3308_TMP_02C thru 02AB.dgn

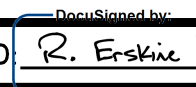

●●●●● PEDESTRIAN DETOUR ROUTE

SEE SHEET TMP-2C FOR PEDESTRIAN SIGNING LEGEND

APPROVED  DATE: 5/13/2016			<p>PEDESTRIAN DETOUR ROUTE</p> <p>PHASE 1</p> <p>STEP 15 & 16</p>
--	---	---	---

DOCUMENT NOT CONSIDERED FINAL
UNLESS ALL SIGNATURES COMPLETED

REVISIONS

PLOT DRIVER: NCDOT_pdf_color_eng_50.plt
 USER: erbrooks
 DATE: 5/12/2016
 TIME: 3:57:57 PM
 FILE: c:\pwworking\tpa\d048729\U-3308_TMP-TMP-02C thru 02AB.dgn

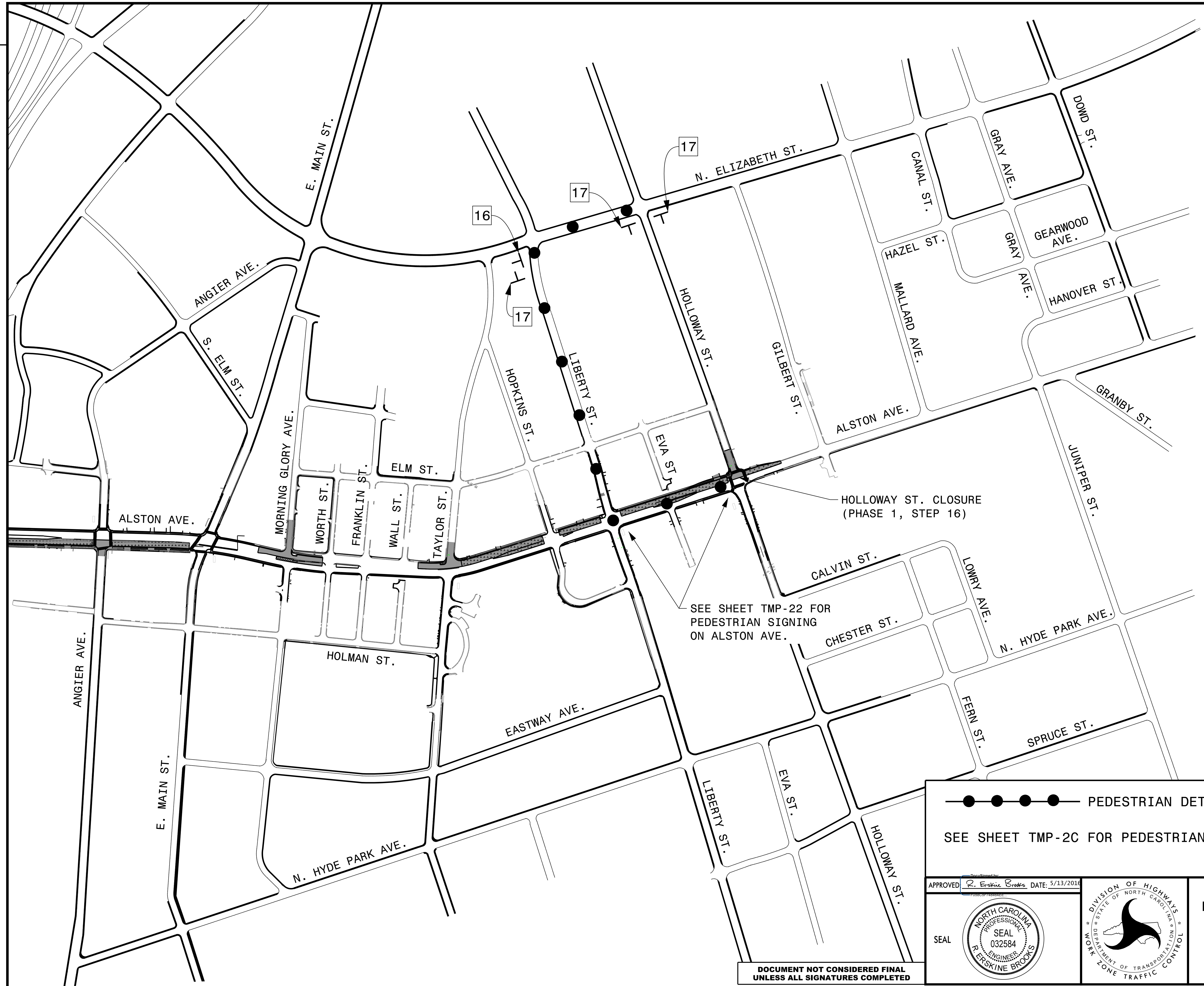

HOLLOWAY ST. CLOSURE (PHASE 1, STEP 16)

SEE SHEET TMP-22 FOR PEDESTRIAN SIGNING ON ALSTON AVE.

●●●● PEDESTRIAN DETOUR ROUTE
 SEE SHEET TMP-2C FOR PEDESTRIAN SIGNING LEGEND

PEDESTRIAN DETOUR ROUTE

PHASE 2
STEP 9

DOCUMENT NOT CONSIDERED FINAL UNLESS ALL SIGNATURES COMPLETED

APPROVED  DATE: 5/13/2016

SEAL

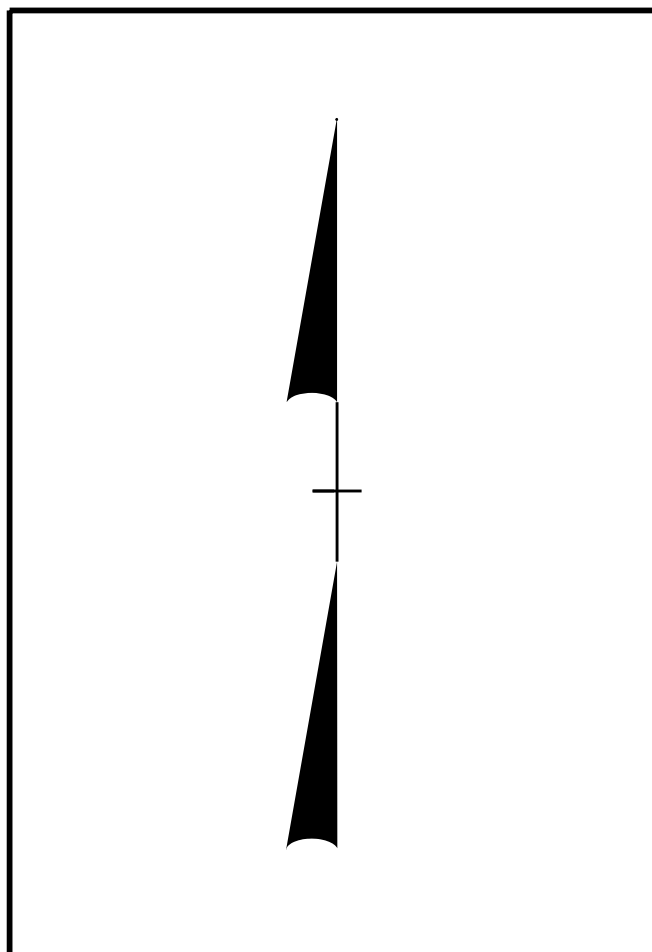
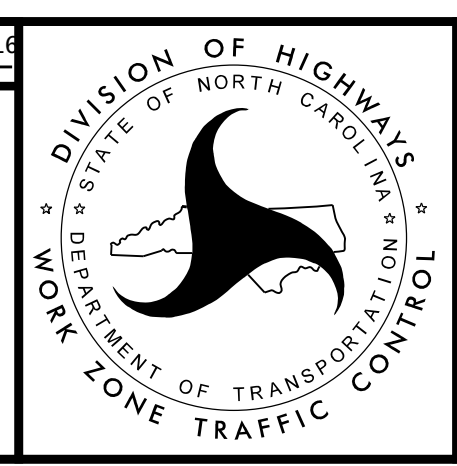

REVISIONS

PLOT DRIVER: NCDOT_pdf_color_eng_50.plt PENTABLE: NCDOT_tcp.tbl
 USER: erbrooks DATE: 5/12/2016 TIME: 3:58:00 PM
 FILE: c:\pwworking\tpa\d048729\U-3308_TMP-02C.thru 02AB.dgn

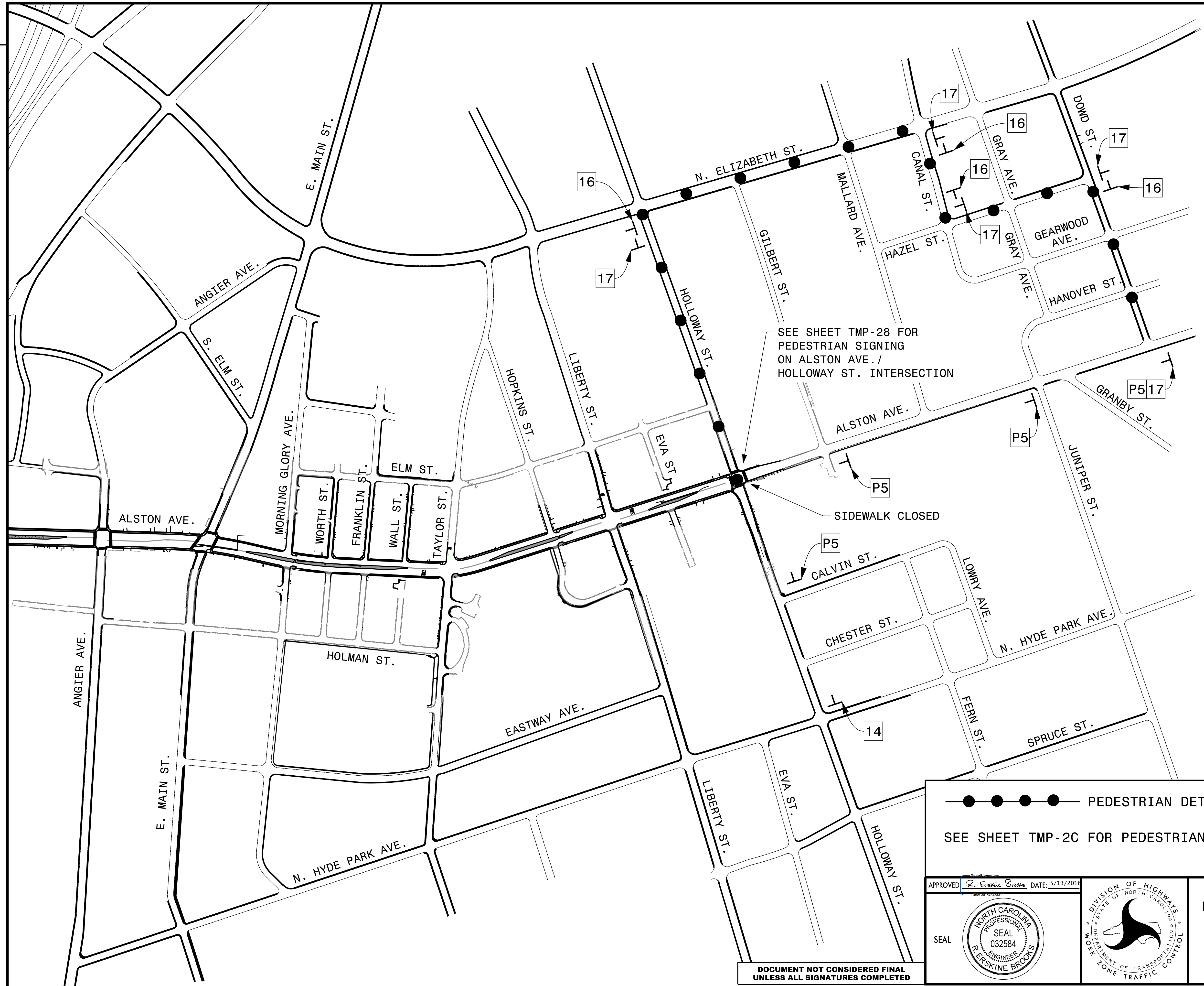

SEE SHEET TMP-28 FOR
 PEDESTRIAN SIGNING
 ON ALSTON AVE./
 HOLLOWAY ST. INTERSECTION

SIDWALK CLOSED

●●●● PEDESTRIAN DETOUR ROUTE
 SEE SHEET TMP-2C FOR PEDESTRIAN SIGNING LEGEND

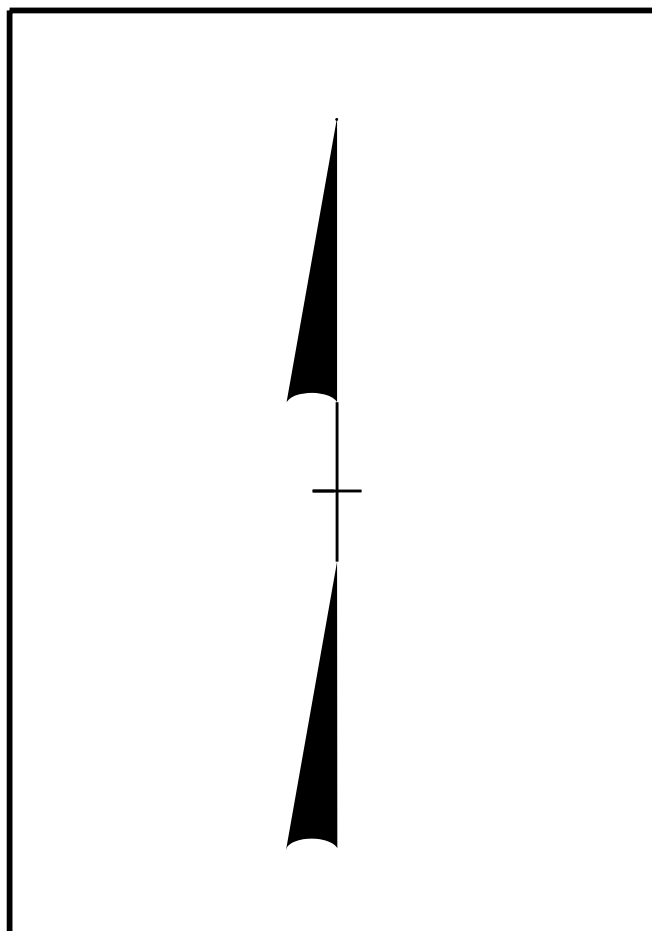

DOCUMENT NOT CONSIDERED FINAL
 UNLESS ALL SIGNATURES COMPLETED

APPROVED  DATE: 5/13/2016

SEAL

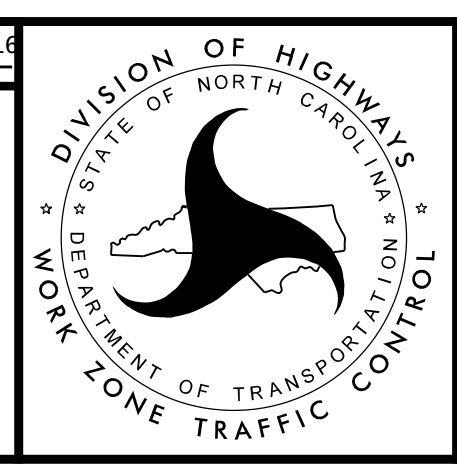

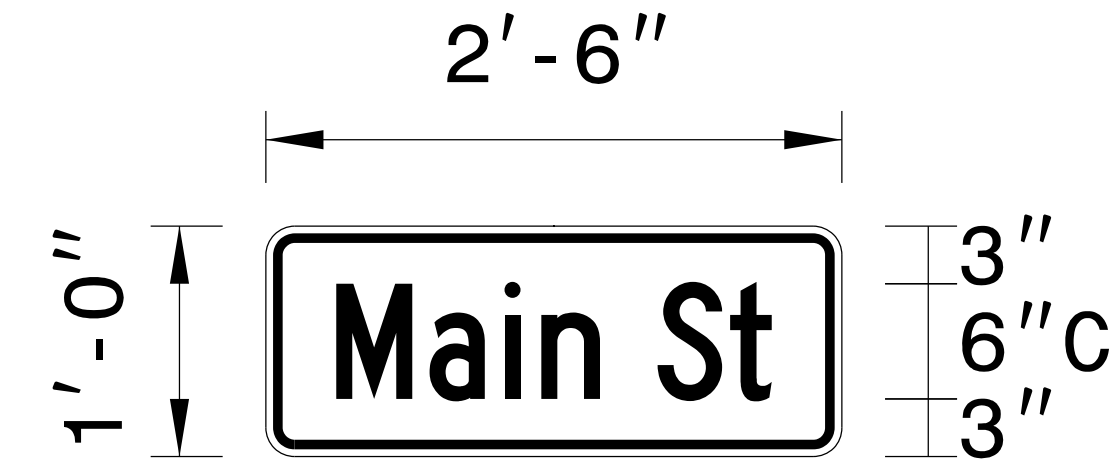

PEDESTRIAN DETOUR ROUTE

PHASE 3
 STEP 2

SIGN NUMBER: SP-10 TYPE: D QUANTITY: 1 SIGN WIDTH: 2'-6" HEIGHT: 1'-0" TOTAL AREA: 2.5 Sq.Ft. BORDER TYPE: FLUSH RECESS: 0.38" WIDTH: 0.38" RADII: 1.5" NO. Z BARS: LENGTH: USE NOTES: 1,2,3 1. Legend and border shall be direct applied Grade C reflective sheeting. 2. Background shall be Grade C reflective sheeting. 3. Shields shall be Grade C reflective sheeting on 0.032" (0.8mm) aluminum and demountable.	BACKG COLOR: Orange COPY COLOR: Black <table border="1" style="width: 100%; border-collapse: collapse;"> <thead> <tr> <th>SYMBOL</th> <th>X</th> <th>Y</th> <th>WIDTH</th> <th>HT</th> </tr> </thead> <tbody> <tr><td> </td><td> </td><td> </td><td> </td><td> </td></tr> <tr><td> </td><td> </td><td> </td><td> </td><td> </td></tr> <tr><td> </td><td> </td><td> </td><td> </td><td> </td></tr> <tr><td> </td><td> </td><td> </td><td> </td><td> </td></tr> <tr><td> </td><td> </td><td> </td><td> </td><td> </td></tr> </tbody> </table> MAT'L: 0.125" (3.2 mm) ALUMINUM	SYMBOL	X	Y	WIDTH	HT																										DESIGN BY: LLT PROJECT ID: U-3308 CHECKED BY: DHK DIV: 4 DATE: Jun 07, 2013 <div style="text-align: center;">  <p style="text-align: center;"> BORDER R=1.5" TH=0.38" IN=0.38" </p> </div>
SYMBOL	X	Y	WIDTH	HT																												

Letter spacings are to start of next letter												Series/Size Text Length
M	a	i	n	S	t							C 2000
3.7	4.9	3.9	1.9	3.1	3	3.8	2.2	3.7				22.7

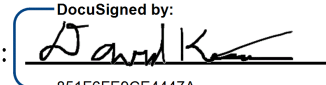
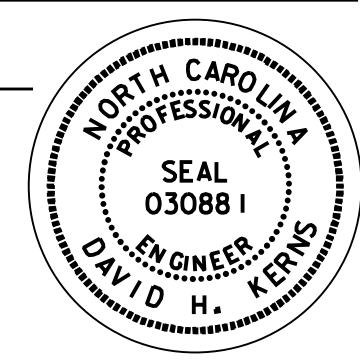
5/12/2016
 C:\pwworking\tpa\d0487729\U-3308_TMP-TMP-02AJ.dgn thru 02AJ.dgn
 12:36:41 PM

APPROVED:  DATE: 5/12/2016 		SPECIAL SIGN DESIGN
DOCUMENT NOT CONSIDERED FINAL UNLESS ALL SIGNATURES COMPLETED		

SIGN NUMBER: SP TYPE: D QUANTITY: 1 SIGN WIDTH: 2'-0" HEIGHT: 2'-6" TOTAL AREA: 5.0 Sq.Ft. BORDER TYPE: FLUSH RECESS: 0.38" WIDTH: 0.63" RADII: 1.5" NO. Z BARS: LENGTH:	BACKG COLOR: Orange COPY COLOR: Black <table border="1" style="width: 100%; text-align: center;"> <tr> <th>SYMBOL</th> <th>X</th> <th>Y</th> <th>WIDTH</th> <th>HEIGHT</th> </tr> <tr><td> </td><td> </td><td> </td><td> </td><td> </td></tr> <tr><td> </td><td> </td><td> </td><td> </td><td> </td></tr> <tr><td> </td><td> </td><td> </td><td> </td><td> </td></tr> <tr><td> </td><td> </td><td> </td><td> </td><td> </td></tr> <tr><td> </td><td> </td><td> </td><td> </td><td> </td></tr> <tr><td> </td><td> </td><td> </td><td> </td><td> </td></tr> <tr><td> </td><td> </td><td> </td><td> </td><td> </td></tr> </table> MAT'L: 0.125" (3.2 mm) ALUMINUM	SYMBOL	X	Y	WIDTH	HEIGHT																																				DESIGN BY: LLT PROJECT ID: U-3308 CHECKED BY: DHK DIV: 4 DATE: Sep 22, 2014
SYMBOL	X	Y	WIDTH	HEIGHT																																						

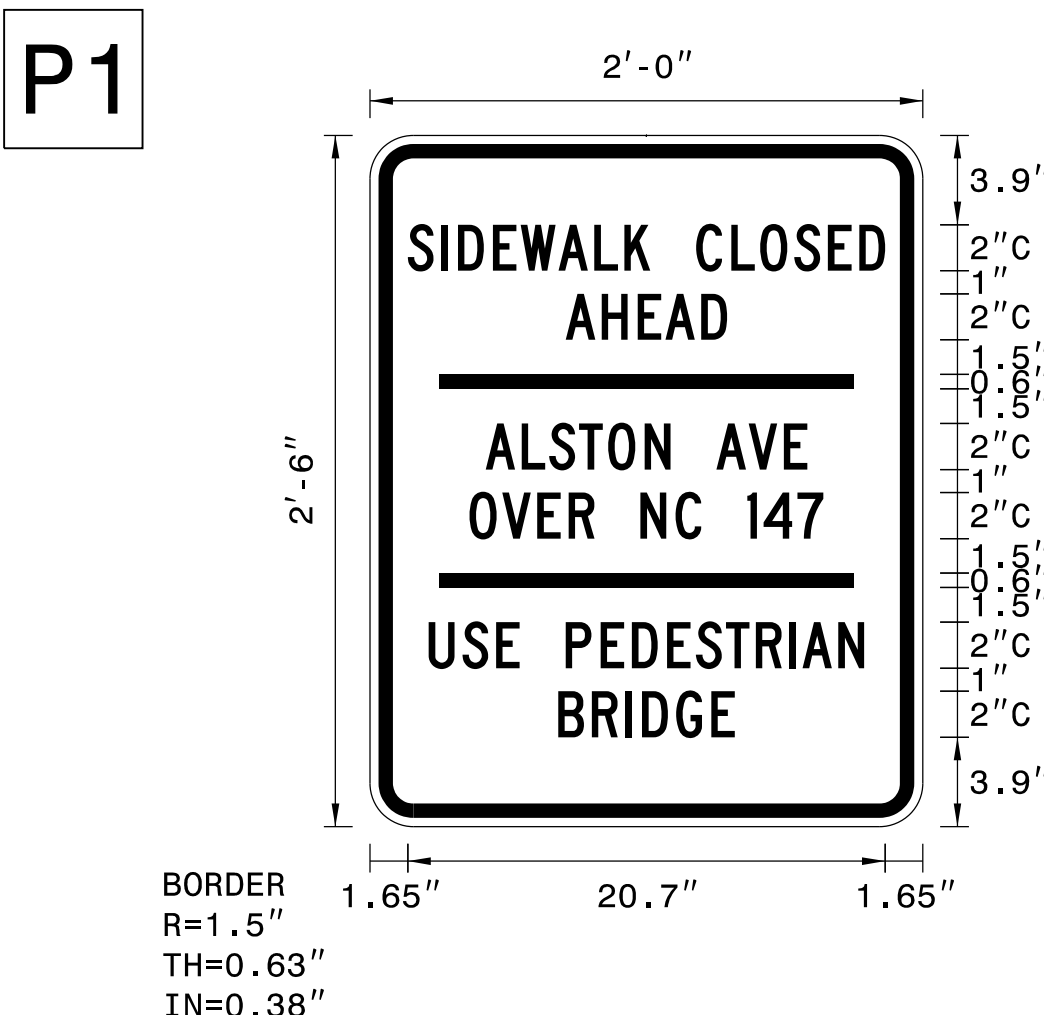

BORDER R=1.5" TH=0.63" IN=0.38"

USE NOTES: 1,2

- Legend and border shall be direct applied non reflective sheeting.
- Background shall be Grade C reflective sheeting.

Letter spacings are to start of next letter																Series/Size	Text Length
S	I	D	E	W	A	L	K		C	L	O	S	E	D			C 2000
1.6	3.1	3.8	5.3	6.5	8.2	9.7	11	12.2	14.2	15.7	16.9	18.4	19.9	21.2			20.7
A	H	E	A	D													C 2000
8.5	10.1	11.6	12.8	14.4													7
A	L	S	T	O	N		A	V	E								C 2000
5	6.6	7.8	9.1	10.3	11.9	13	15	16.4	18							14	
O	V	E	R		N	C		1	4	7							C 2000
4.3	5.7	7.3	8.6	9.7	11.7	13.3	14.4	16.4	17.1	18.6							15.4
U	S	E		P	E	D	E	S	T	R	I	A	N				C 2000
2.6	4	5.5	6.5	8.5	10	11.4	12.9	14.2	15.5	16.8	18.2	18.8	20.3				18.9
B	R	I	D	G	E												C 2000
8.2	9.6	11.1	11.8	13.3	14.8												7.7

5/12/2016 12:36:44 PM
 C:\pwworking\tpo\d0487729\U-3308_TMP-02AC thru 02AT.dgn

APPROVED: 
 DATE: 5/12/2016

NORTH CAROLINA
 PROFESSIONAL
 SEAL
 030881
 ENGINEER
 DAVID H. KERNS

**DOCUMENT NOT CONSIDERED FINAL
UNLESS ALL SIGNATURES COMPLETED**

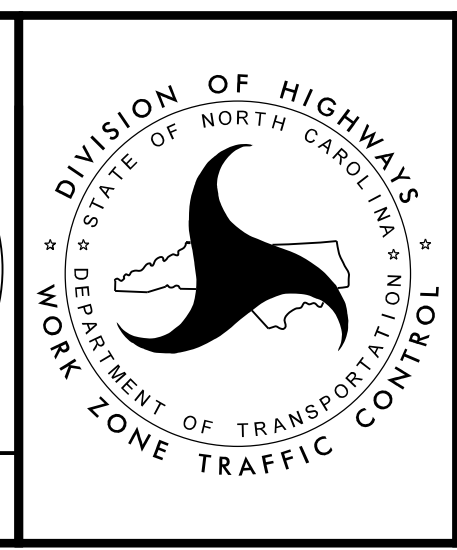

SPECIAL SIGN
DESIGN

SIGN NUMBER: SP TYPE: D QUANTITY: 1 SIGN WIDTH: 2'-0" HEIGHT: 2'-6" TOTAL AREA: 5.0 Sq.Ft. BORDER TYPE: FLUSH RECESS: 0.38" WIDTH: 0.63" RADII: 1.5" NO. Z BARS: LENGTH:	BACKG COLOR: Orange COPY COLOR: Black <table border="1" style="width: 100%; text-align: center;"> <tr> <th>SYMBOL</th> <th>X</th> <th>Y</th> <th>WIDTH</th> <th>HEIGHT</th> </tr> <tr><td> </td><td> </td><td> </td><td> </td><td> </td></tr> <tr><td> </td><td> </td><td> </td><td> </td><td> </td></tr> <tr><td> </td><td> </td><td> </td><td> </td><td> </td></tr> <tr><td> </td><td> </td><td> </td><td> </td><td> </td></tr> <tr><td> </td><td> </td><td> </td><td> </td><td> </td></tr> <tr><td> </td><td> </td><td> </td><td> </td><td> </td></tr> <tr><td> </td><td> </td><td> </td><td> </td><td> </td></tr> </table> MAT'L: 0.125" (3.2 mm) ALUMINUM	SYMBOL	X	Y	WIDTH	HEIGHT																																				DESIGN BY: LLT PROJECT ID: U-3308 CHECKED BY: DHK DIV: 4 DATE: Sep 22, 2014
SYMBOL	X	Y	WIDTH	HEIGHT																																						

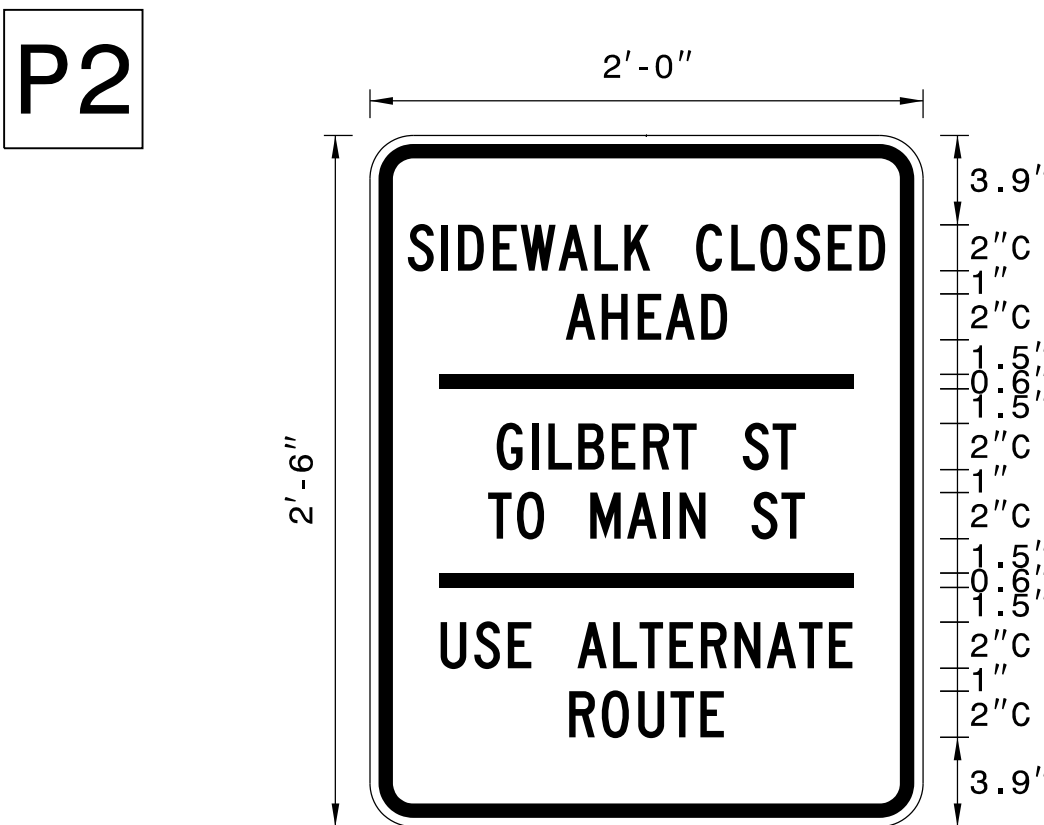



BORDER R=1.5" TH=0.63" IN=0.38"

USE NOTES: 1,2

- Legend and border shall be direct applied non reflective sheeting.
- Background shall be Grade C reflective sheeting.

Letter spacings are to start of next letter																Series/Size	Text Length
S	I	D	E	W	A	L	K		C	L	O	S	E	D			C 2000
1.6	3.1	3.8	5.3	6.5	8.2	9.7	11	12.2	14.2	15.7	16.9	18.4	19.9	21.2			20.7
A	H	E	A	D													C 2000
8.5	10.1	11.6	12.8	14.4													7
G	I	L	B	E	R	T		S	T								C 2000
5.5	7	7.7	9	10.5	11.9	13.2	14.2	16.2	17.5								13
T	O		M	A	I	N		S	T								C 2000
5.1	6.4	7.6	9.6	11.2	12.7	13.4	14.6	16.6	17.9								13.8
U	S	E		A	L	T	E	R	N	A	T	E					C 2000
3.1	4.5	6	7	9	10.6	11.7	13	14.4	15.8	17.2	18.6	19.9					17.9
R	O	U	T	E													C 2000
8.6	10.1	11.6	13	14.3													6.7

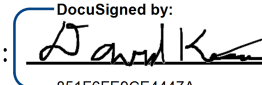
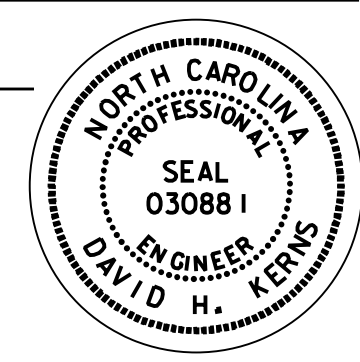
5/12/2016 12:36:44 PM
 C:\pwworking\tpo\d0487729\U-3308_TMP-TMP-02AC thru 02AT.dgn

APPROVED:  DATE: 5/12/2016			SPECIAL SIGN DESIGN
DOCUMENT NOT CONSIDERED FINAL UNLESS ALL SIGNATURES COMPLETED			

SIGN NUMBER: SP TYPE: D QUANTITY: 1 SIGN WIDTH: 2'-0" HEIGHT: 2'-6" TOTAL AREA: 5.0 Sq.Ft. BORDER TYPE: FLUSH RECESS: 0.38" WIDTH: 0.63" RADII: 1.5" NO. Z BARS: LENGTH:	BACKG COLOR: Orange COPY COLOR: Black <table border="1" style="width: 100%; text-align: center;"> <thead> <tr> <th>SYMBOL</th> <th>X</th> <th>Y</th> <th>WIDTH</th> <th>HEIGHT</th> </tr> </thead> <tbody> <tr><td> </td><td> </td><td> </td><td> </td><td> </td></tr> <tr><td> </td><td> </td><td> </td><td> </td><td> </td></tr> <tr><td> </td><td> </td><td> </td><td> </td><td> </td></tr> <tr><td> </td><td> </td><td> </td><td> </td><td> </td></tr> <tr><td> </td><td> </td><td> </td><td> </td><td> </td></tr> <tr><td> </td><td> </td><td> </td><td> </td><td> </td></tr> <tr><td> </td><td> </td><td> </td><td> </td><td> </td></tr> </tbody> </table> MAT'L: 0.125" (3.2 mm) ALUMINUM	SYMBOL	X	Y	WIDTH	HEIGHT																																				DESIGN BY: LLT PROJECT ID: U-3308 CHECKED BY: DHK DIV: 4 DATE: Sep 22, 2014
SYMBOL	X	Y	WIDTH	HEIGHT																																						

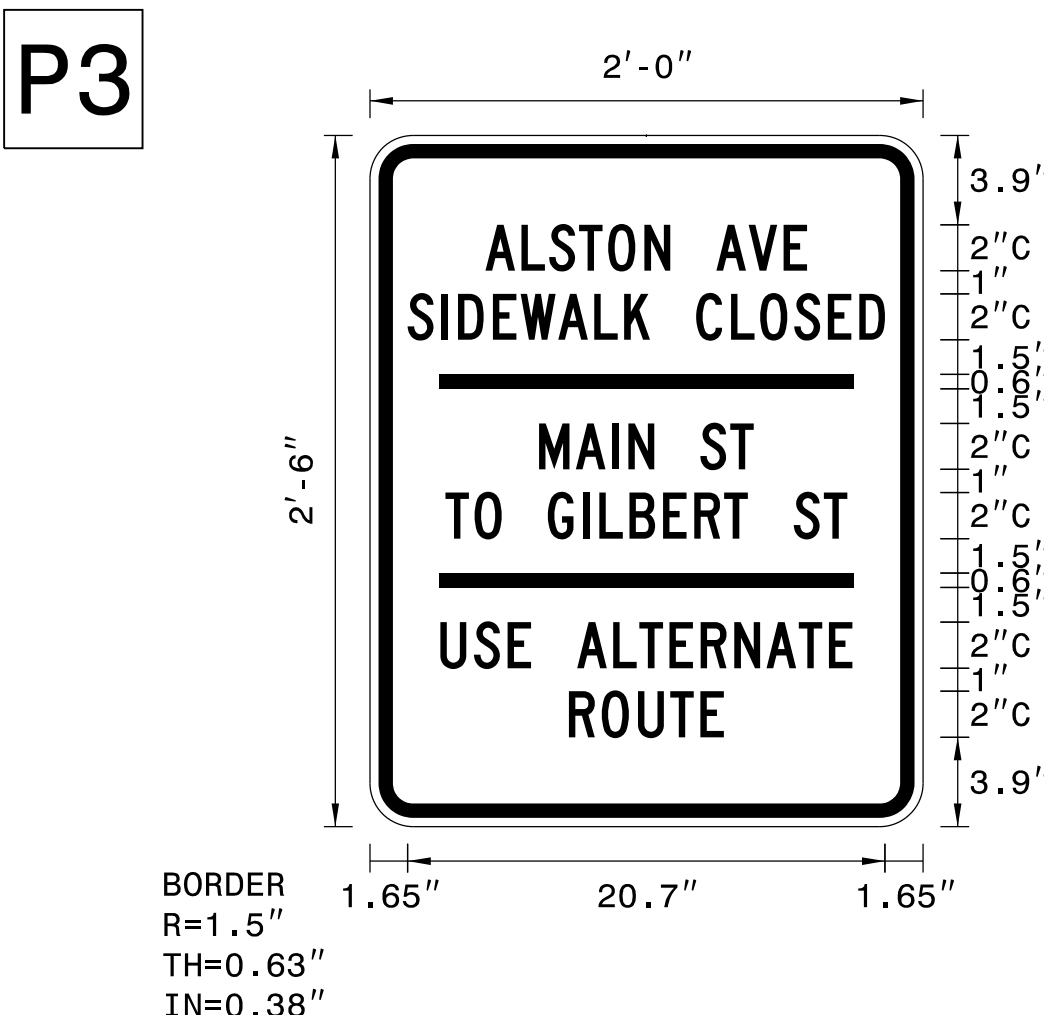



USE NOTES: 1,2

- Legend and border shall be direct applied non reflective sheeting.
- Background shall be Grade C reflective sheeting.

Letter spacings are to start of next letter																Series/Size	Text Length
A	L	S	T	O	N	A	V	E								C 2000	14
5	6.6	7.8	9.1	10.3	11.9	13	15	16.4	18							C 2000	20.7
S	I	D	E	W	A	L	K	C	L	O	S	E	D			C 2000	20.7
1.6	3.1	3.8	5.3	6.5	8.2	9.7	11	12.2	14.2	15.7	16.9	18.4	19.9	21.2		C 2000	9.3
M	A	I	N	S	T											C 2000	17.4
7.3	8.9	10.5	11.2	12.3	14.3	15.6										C 2000	17.9
T	O	G	I	L	B	E	R	T	S	T						C 2000	6.7
3.3	4.5	5.7	7.7	9.2	10	11.3	12.7	14.1	15.4	16.4	18.4	19.7				C 2000	
U	S	E	A	L	T	E	R	N	A	T	E					C 2000	
3.1	4.5	6	7	9	10.6	11.7	13	14.4	15.8	17.2	18.6	19.9				C 2000	
R	O	U	T	E												C 2000	
8.6	10.1	11.6	13	14.3													

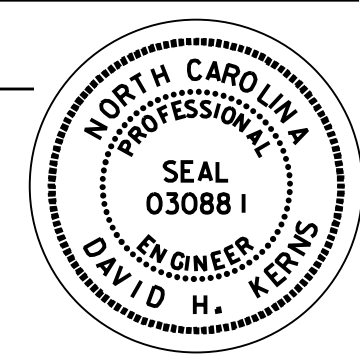
5/12/2016 12:36:45 PM C:\pwworking\tpo\d0487729\U-3308_TMP-02AC thru 02AT.dgn

APPROVED:  DATE: 5/12/2016 		SPECIAL SIGN DESIGN
DOCUMENT NOT CONSIDERED FINAL UNLESS ALL SIGNATURES COMPLETED		

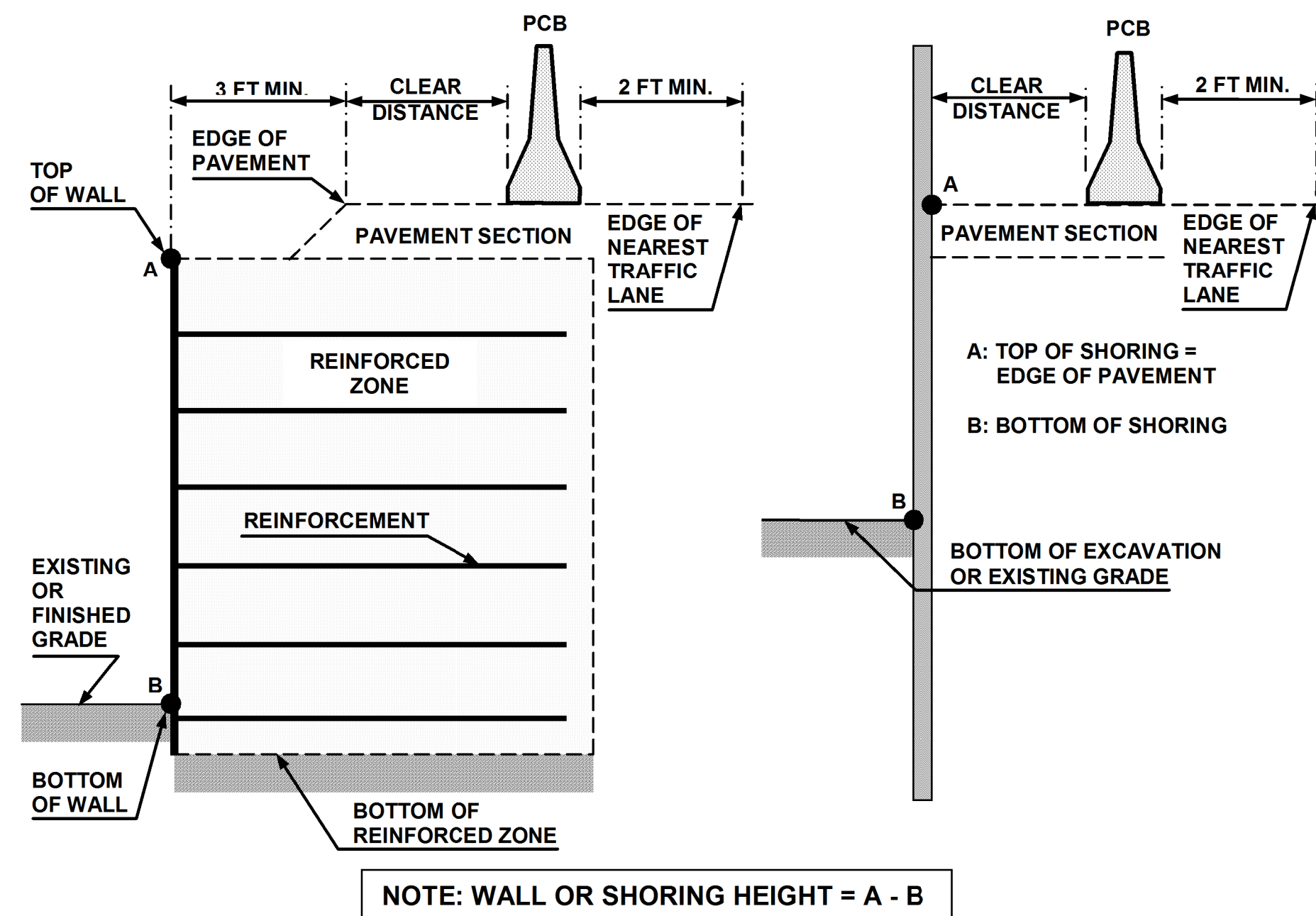

FIGURE A

NOTES

- REFER TO THE TRAFFIC CONTROL PLANS FOR TEMPORARY SHORING LOCATIONS AND NOTES.
- REFER TO THE "TEMPORARY SHORING" PROJECT SPECIAL PROVISION FOR INFORMATION ABOUT TEMPORARY SHORING AND PORTABLE CONCRETE BARRIER (PCB).
- PCB IS REQUIRED IF TEMPORARY SHORING IS LOCATED WITHIN THE CLEAR ZONE IN ACCORDANCE WITH THE AASHTO ROADSIDE DESIGN GUIDE. DO NOT PLACE BARRIER DIRECTLY ON ANY SURFACE OTHER THAN ASPHALT OR CONCRETE. (CONTACT NCDOT PAVEMENT MANAGEMENT UNIT FOR APPLICABLE PAVEMENT DESIGN).
- BASED ON THE CLEAR DISTANCE, OFFSET, DESIGN SPEED AND PAVEMENT TYPE, CHOOSE AN UNANCHORED OR ANCHORED PCB FROM THE TABLE SHOWN IN FIGURE B. CLEAR DISTANCE IS DEFINED AS SHOWN IN FIGURE A AND OFFSET IS DEFINED AS SHOWN IN FIGURE B.
- AT THE CONTRACTOR'S OPTION OR IF THE MINIMUM REQUIRED CLEAR DISTANCE IS NOT AVAILABLE, SET PCB NEXT TO AND UP AGAINST THE TRAFFIC SIDE OF THE TEMPORARY SHORING EXCEPT FOR BARRIER ABOVE TEMPORARY WALLS. PCB WITH THE MINIMUM REQUIRED CLEAR DISTANCE IS REQUIRED ABOVE TEMPORARY WALLS.
- USE NCDOT PORTABLE CONCRETE BARRIER (PCB) IN ACCORDANCE WITH ROADWAY STANDARD DRAWING NO. 1170.01 AND SECTION 1170 OF THE STANDARD SPECIFICATIONS.
- PCB REQUIREMENTS FOR TEMPORARY WALLS APPLY TO TEMPORARY MECHANICALLY STABILIZED EARTH (MSE) WALLS AND TEMPORARY SOIL NAIL WALLS.
- SET PCB WITH A MINIMUM HORIZONTAL DISTANCE OF 2 FT BETWEEN THE FRONT FACE OF THE BARRIER AND THE EDGE OF THE NEAREST TRAFFIC LANE AS SHOWN IN FIGURE A UNLESS OTHERWISE SHOWN IN THE PLANS AND OR AS APPROVED BY THE ENGINEER.
- FOR PCB ABOVE AND BEHIND TEMPORARY WALLS, PROVIDE A MINIMUM DISTANCE OF 3 FT BETWEEN THE EDGE OF PAVEMENT AND THE WALL FACE AS SHOWN IN FIGURE A. IF THESE MINIMUM REQUIRED DISTANCES ARE NOT AVAILABLE, CONTACT THE ENGINEER.
- TABLE SHOWN IN FIGURE B IS BASED ON NCDOT RESEARCH PROJECT NO. 2005-010 WITH VEHICLE TYPE USED FOR NCHRP 350 CRASH TESTS. BARRIER DEFLECTIONS AND RESULTING MINIMUM REQUIRED CLEAR DISTANCES MIGHT VARY SIGNIFICANTLY FOR LARGER HEAVIER VEHICLES, RUNS OF BARRIER LESS THAN 200 FT IN LENGTH AND WET OR DRY PAVEMENT.

MINIMUM REQUIRED CLEAR DISTANCE, inches

Barrier Type	Pavement Type	Offset * ft	Design Speed, mph					
			<30	31-40	41-50	51-60	61-70	71-80
Unanchored PCB	Asphalt	<8	24	26	29	32	36	40
		8-14	26	28	31	35	38	42
		14-20	27	29	34	36	39	43
		20-26	28	31	35	38	40	44
		26-32	29	32	36	39	42	45
		32-38	30	34	38	41	43	46
		38-44	31	34	41	43	45	48
		44-50	31	35	41	43	46	49
		50-56	32	36	42	44	47	50
	>56	32	36	42	45	47	51	
	Concrete	<8	17	18	21	22	25	26
		8-14	19	20	23	25	26	29
		14-20	22	22	24	26	28	31
		20-26	23	24	26	27	30	34
		26-32	24	25	27	28	32	35
		32-38	24	26	27	30	33	36
		38-44	25	26	28	30	34	37
		44-50	26	26	28	32	35	37
50-56		26	26	28	32	35	38	
>56	26	27	29	32	36	38		
Anchored PCB	Asphalt	All Offsets	24 for All Design Speeds					
Anchored PCB	Concrete (including bridge approach slabs)	All Offsets	12 for All Design Speeds					

* See Figure Below

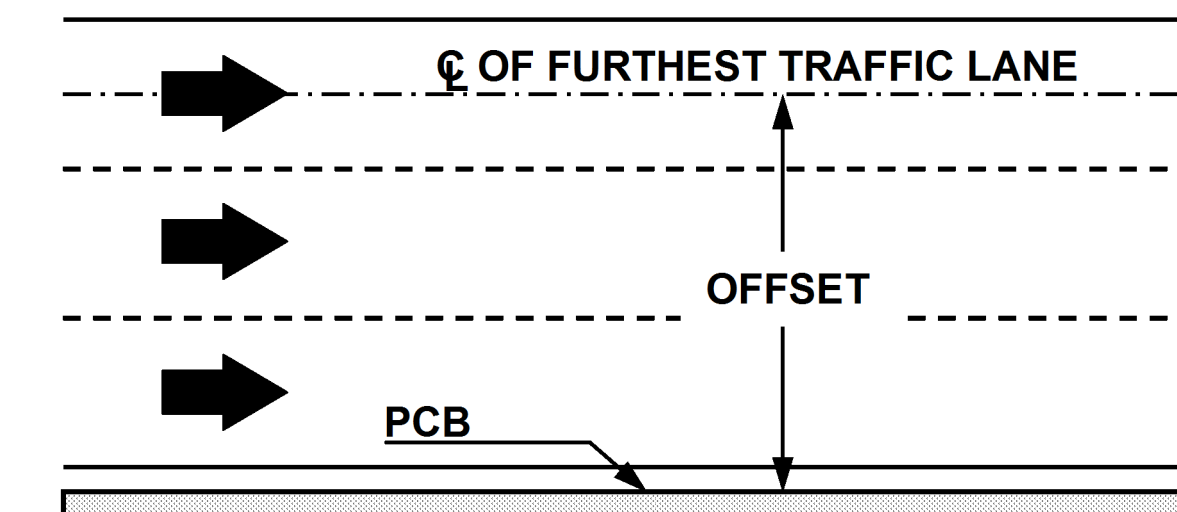
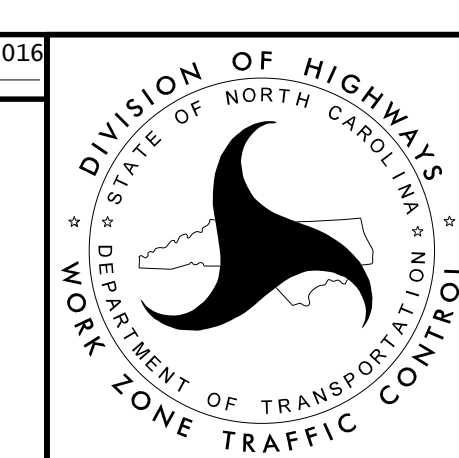
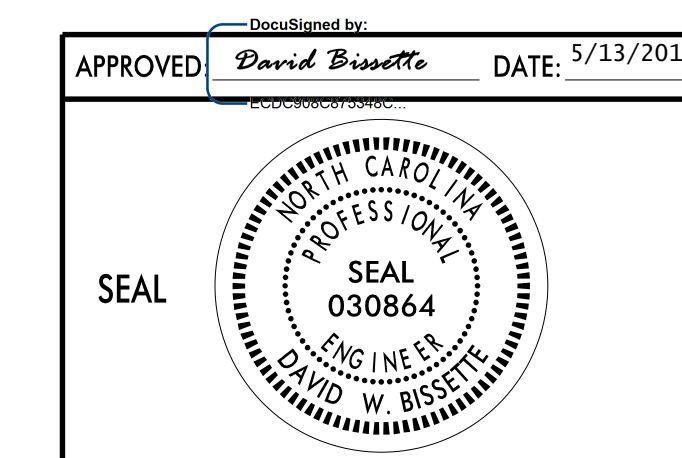
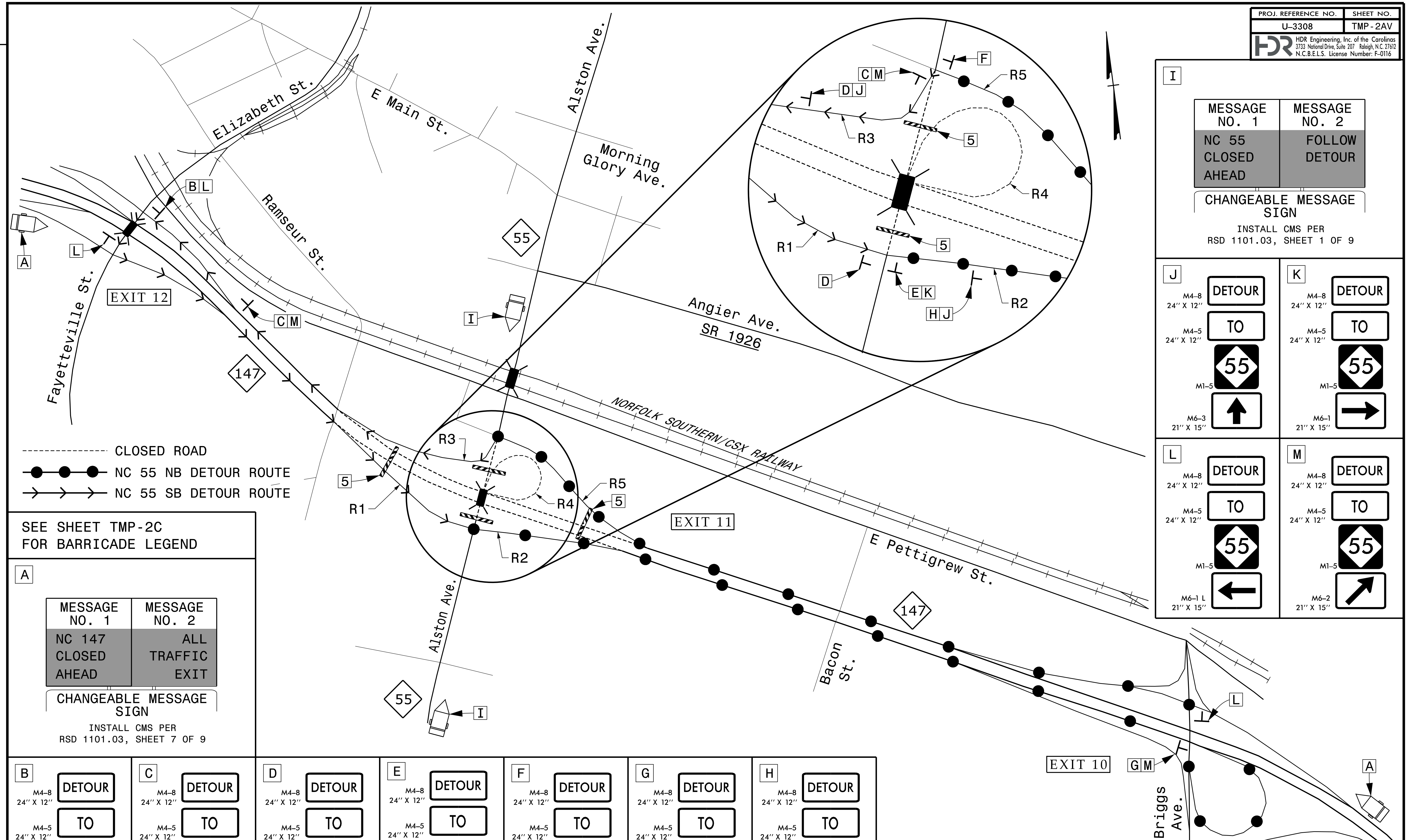

FIGURE B

DOCUMENT NOT CONSIDERED FINAL
UNLESS ALL SIGNATURES COMPLETED



PORTABLE CONCRETE BARRIER
AT
TEMPORARY SHORING LOCATIONS



- - - - - CLOSED ROAD
 ● - ● - ● - NC 55 NB DETOUR ROUTE
 > - > - > - NC 55 SB DETOUR ROUTE

SEE SHEET TMP-2C FOR BARRICADE LEGEND

A

MESSAGE NO. 1	MESSAGE NO. 2
NC 147 CLOSED AHEAD	ALL TRAFFIC EXIT

CHANGEABLE MESSAGE SIGN

INSTALL CMS PER RSD 1101.03, SHEET 7 OF 9

B

M4-8 24" X 12" **DETOUR**

M4-5 24" X 12" **TO**

M3-3 24" X 12" **SOUTH**

M1-5 

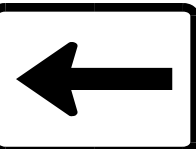
M6-1 L 21" X 15" 

C

M4-8 24" X 12" **DETOUR**

M4-5 24" X 12" **TO**

M3-3 24" X 12" **SOUTH**

M1-5 

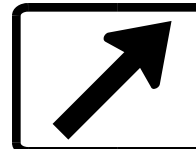
M6-2 21" X 15" 

D

M4-8 24" X 12" **DETOUR**

M4-5 24" X 12" **TO**

M3-3 24" X 12" **SOUTH**

M1-5 

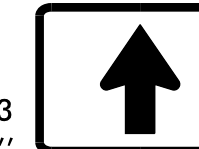
M6-3 21" X 15" 

E

M4-8 24" X 12" **DETOUR**

M4-5 24" X 12" **TO**

M3-1 24" X 12" **NORTH**

M1-5 

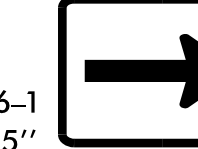
M6-1 21" X 15" 

F

M4-8 24" X 12" **DETOUR**

M4-5 24" X 12" **TO**

M3-1 24" X 12" **NORTH**

M1-5 

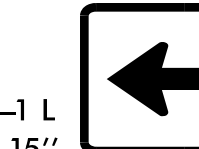
M6-1 L 21" X 15" 

G

M4-8 24" X 12" **DETOUR**

M4-5 24" X 12" **TO**

M3-1 24" X 12" **NORTH**

M1-5 

M6-2 21" X 15" 

H

M4-8 24" X 12" **DETOUR**

M4-5 24" X 12" **TO**

M3-1 24" X 12" **NORTH**

M1-5 

M6-3 21" X 15" 

I

MESSAGE NO. 1	MESSAGE NO. 2
NC 55 CLOSED AHEAD	FOLLOW DETOUR

CHANGEABLE MESSAGE SIGN

INSTALL CMS PER RSD 1101.03, SHEET 1 OF 9

J

M4-8 24" X 12" **DETOUR**

M4-5 24" X 12" **TO**

M1-5 

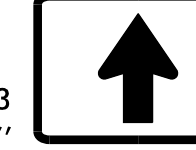
M6-3 21" X 15" 

K

M4-8 24" X 12" **DETOUR**

M4-5 24" X 12" **TO**

M1-5 

M6-1 21" X 15" 

L

M4-8 24" X 12" **DETOUR**

M4-5 24" X 12" **TO**

M1-5 

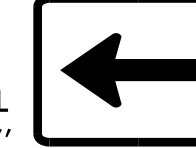
M6-1 L 21" X 15" 

M

M4-8 24" X 12" **DETOUR**

M4-5 24" X 12" **TO**

M1-5 

M6-2 21" X 15" 

PLOT DRIVER: NCDOT_pdf_color_eng_50.ppt
 USER: erbrooks
 PENTABLE: NCDOT_tcp.tbl
 DATE: 5/12/2016
 TIME: 3:58:01 PM
 FILE: c:\pwworking\tpa\d048729\U-3308_TMP-TMP-02C thru 02AB.dgn

REVISIONS

DOCUMENT NOT CONSIDERED FINAL UNLESS ALL SIGNATURES COMPLETED

APPROVED:  DATE: 5/13/2016

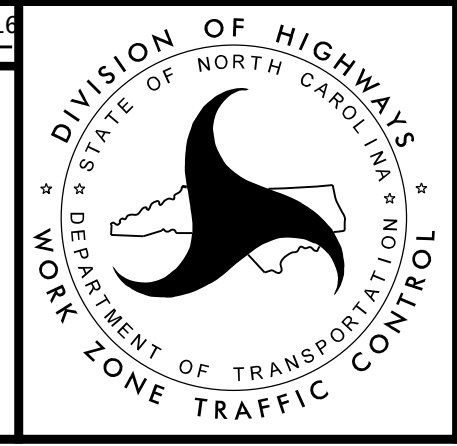
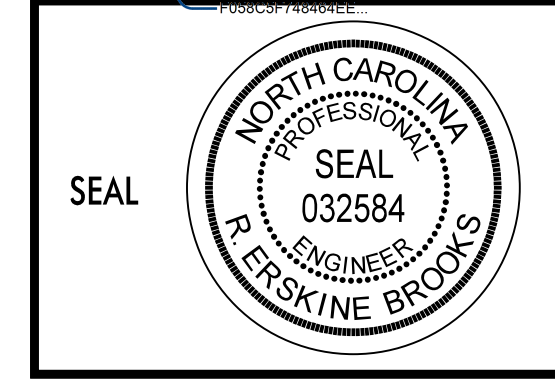

NC 147 & NC 55 CLOSURE FOR BRIDGE WORK

DETOUR ROUTES

PROJ. REFERENCE NO.	SHEET NO.
U-3308	TMP-3
 HDR Engineering, Inc. of the Carolinas 3733 National Drive, Suite 207 Raleigh, N.C. 27612 N.C.B.E.L.S. License Number: F-0116	

PHASING

NOTES:

BEFORE BEGINNING ANY CONSTRUCTION ACTIVITIES, THE CONTRACTOR SHALL INSTALL ALL ADVANCE WARNING SIGNS (PER RSD 1101.01) AND TRAFFIC CONTROL DEVICES. FIELD VERIFY LOCATIONS WITH THE RESIDENT ENGINEER PRIOR TO INSTALLATION.

MAINTAIN ACCESS TO ALL RESIDENCES AND BUSINESSES DURING THE LIFE OF THE CONTRACT, UNLESS OTHERWISE NOTED IN THE PHASING OR AS DIRECTED BY THE ENGINEER.

COMPLETE ANY PROPOSED OR TEMPORARY WIDENING IN SUCH A MANNER THAT NO PONDING OF WATER WILL OCCUR WITHIN THE TRAVEL LANE.

WHEN USING LANE CLOSURES (RSD 1101.02), RETURN TRAFFIC TO EXISTING PATTERN(S) AT THE END OF THE ALLOWABLE WORK PERIOD.

PAVE PROPOSED CONSTRUCTION UP TO BUT NOT INCLUDING THE FINAL LAYER OF SURFACE COURSE, IN ALL PHASES, UNLESS OTHERWISE NOTED IN THE PHASING, UNTIL STATED TO INSTALL THE FINAL LAYER OF SURFACE COURSE IN THE PHASING.

COMPLETE STAMPED CONCRETE CROSSWALKS WITHIN THE RESPECTIVE WORK AREAS OF EACH PHASE AND STEP WHERE SHOWN IN THE PLANS. PLACE THE FINAL LAYER OF ASPHALT SURFACE COURSE WITHIN EACH INTERSECTION TO THE LIMITS OF THE CONSTRUCTED CONCRETE CROSSWALKS.

COVER ALL OPEN DRAINAGE STRUCTURES ADJACENT TO TRAFFIC WITH TEMPORARY STEEL PLATES, OR AS DIRECTED BY THE ENGINEER.

PHASE 1 (SHEETS TMP-5 - TMP-8)

STEP 1:

AWAY FROM TRAFFIC, USING FLAGGERS AND LANE CLOSURES (RSD 1101.02, SHEET 1 OF 15) AND BY STOPPING TRAFFIC AS PERMITTED (RSD 1101.03, SHEET 8 OF 9), BEGIN REMOVAL OF THE OVERHEAD COMPONENTS AND PIERS OF THE EXISTING CSX AND ABANDONED RAILROAD BRIDGES OVER -LALT- (NC 55). (SEE LOCAL NOTE LN-02)

USING LANE CLOSURES (RSD 1101.02, SHEET 4 OF 15), REMOVE EXISTING GUARDRAIL ALONG -YA- (NC 147) UNDER THE EXISTING -LALT- (NC 55) BRIDGE, AND INSTALL TEMPORARY GUARDRAIL (AS SHOWN ON SHEET TMP-5).

AWAY FROM TRAFFIC AND USING FLAGGERS, LANE CLOSURES, AND SHOULDER CLOSURES (RSD 1101.02, SHEETS 1, 2, 3, AND 7 OF 15, AND RSD 1101.04) AND LAW ENFORCEMENT AS NECESSARY, BEGIN INSTALLATION OF TEMPORARY SIGNALS 05-0228T1, 05-0284T1, 05-1026T1, 05-1027T1, 05-1028T1, 05-1029T1, AND 05-1030T1.

PERMANENTLY CLOSE -Y13- (WALL STREET; EAST SIDE OF -LALT-, SHEET TMP-7) AND -Y20- (EVA STREET; WEST SIDE OF -LALT-, SHEET TMP-8) AND COMPLETE ASSOCIATED WORK AT EACH LOCATION.

INSTALL PEDESTRIAN DETOUR SIGNING FOR CLOSURE OF THE SIDEWALK ON THE EXISTING NC 55 BRIDGE OVER NC 147. (SEE SHEET TMP-2X FOR PEDESTRIAN DETOUR ROUTE)

THE CONTRACTOR MAY CONDUCT WORK IN PHASE 1, STEP 2 CONCURRENTLY WITH PHASE 1, STEPS 3, 4, AND 5 - 7. PHASE 1, STEP 2 MAY NOT BE COMPLETED CONCURRENTLY WITH PHASE 1, STEP 3A OR STEP 4A, AND AS NOTED IN LOCAL NOTE LN-02 (SEE SHEET TMP-2A).

THE CONTRACTOR SHALL COMPLETE THE WORK REQUIRED IN PHASE 1, STEP 2 DURING A WEEKEND OPERATION. (SEE INTERMEDIATE CONTRACT TIME AND LIQUIDATED DAMAGES)

STEP 2:

CONDUCT WORK ON -LALT- (NC 55 / ALSTON AVE) IN THE FOLLOWING SEQUENCE: (SEE SHEET TMP-5)

1. USING RSD 1101.03, SHEET 1 OF 9, DETOUR AND CLOSE EXISTING NC 55 (SEE SHEET TMP-2D FOR DETOUR ROUTE).
2. COMPLETE REMOVAL OF THE EXISTING CSX RAIL BRIDGE AND ABANDONED RAIL BRIDGE PIER FOUNDATIONS ADJACENT TO THE EXISTING NB NC 55 TRAVEL LANES. (SEE CUT SECTION B1-B1 ON SHEET TMP-4A)
3. BACKFILL AND REPAIR EXISTING NC 55, INCLUDING INSTALLATION OF TEMPORARY PAVEMENT FOR TEMPORARY WALKWAY.
4. PLACE PORTABLE CONCRETE BARRIER (PCB), TEMPORARY 6' FENCING ADJACENT TO THE TEMPORARY WALKWAY, AND TEMPORARY PAVEMENT MARKINGS ALONG NC 55 FROM -LALT- STA. 22+50 +/- TO STA. 27+50 +/- (AS SHOWN ON SHEET TMP-5). (NOTE - IF PHASE 1, STEP 2 IS NOT COMPLETED IN CONJUNCTION WITH PHASE 1, STEP 3, TIE TEMPORARY MARKINGS AT -LALT- STA. 22+50 +/- TO THE EXISTING MARKINGS.)
5. REMOVE THE DETOUR AND REOPEN NC 55.

STEP 3:

WORKING IN A CONTINUOUS MANNER, AWAY FROM TRAFFIC AND USING FLAGGERS, LANE CLOSURES, AND SHOULDER CLOSURES (RSD 1101.02, SHEETS 1, 2, AND 7 OF 15, AND RSD 1101.04) AND LAW ENFORCEMENT AS NECESSARY, COMPLETE INSTALLATION OF TEMPORARY SIGNALS 05-0284T1 AND 05-1028T1, PLACE TEMPORARY PAVEMENT MARKINGS ON NC 55 (-LALT- STA. 13+20 +/- TO STA. 22+50 +/-), -R1-, -R3-, AND -R4-, AND SHIFT TRAFFIC TO THE TEMPORARY PATTERN. (SEE SHEET TMP-5)

AWAY FROM TRAFFIC, USING FLAGGERS AND LANE CLOSURES (RSD 1101.02, SHEET 1 OF 15) AND BY STOPPING TRAFFIC AS PERMITTED (RSD 1101.03, SHEET 8 OF 9), BEGIN TRACK CONSTRUCTION OF THE CSX RAIL AND RAIL DETOUR LINES. BEGIN CONSTRUCTION OF THE CSX RAIL BRIDGE OVER -LALT-, INCLUDING THE TEMPORARY SPAN OVER NC 55 AS SHOWN IN THE RAIL BRIDGE STRUCTURE PLANS. (SEE SHEET TMP-5 AND LOCAL NOTE LN-02, SHEET TMP-2A)

AWAY FROM TRAFFIC AND USING FLAGGERS AND LANE CLOSURES (RSD 1101.02, SHEETS 1 AND 2 OF 15) AS NECESSARY, BEGIN CONSTRUCTION OF THE FOLLOWING: (SEE SHEETS TMP-5 AND TMP-6)

- -LALT- FROM STA. 24+38 +/- TO STA. 31+00 +/- (LT)
- -LALT- FROM STA. 32+00 +/- TO STA. 36+00 +/- (LT)

WORKING IN A CONTINUOUS MANNER, AWAY FROM TRAFFIC AND USING FLAGGERS, LANE CLOSURES (RSD 1101.02, SHEETS 1, 2, AND 7 OF 15, AND RSD 1101.04) AND LAW ENFORCEMENT AS NECESSARY, COMPLETE INSTALLATION OF AND ACTIVATE TEMPORARY SIGNAL 05-1026T1, THEN USING RSD 1101.03, SHEET 1 OF 9, CLOSE AND DETOUR -Y1- (ANGIER AVENUE). (SEE SHEET TMP-2K FOR DETOUR ROUTE) UPON CLOSURE OF -Y1-, AWAY FROM TRAFFIC AND USING FLAGGERS AND LANE CLOSURES (RSD 1101.02, SHEETS 1 AND 2 OF 15) AS NECESSARY, BEGIN CONSTRUCTION OF THE FOLLOWING: (SEE SHEET TMP-6)

- -Y1- FROM STA. 11+00 +/- TO STA. 12+41 +/-
- -LALT- FROM STA. 31+00 +/- TO STA. 32+00 +/- (LT), INCLUDING TEMPORARY PAVEMENT (STA. 31+00 +/- TO STA. 32+00 +/-) TO PROVIDE A CONNECTION FROM EXISTING NC 55 PAVEMENT TO THE NEW -LALT- PAVEMENT AND -Y1- INTERSECTION. (SEE SHEET TMP-6)

AWAY FROM TRAFFIC AND USING FLAGGERS AND LANE CLOSURES (RSD 1101.02, SHEETS 1 AND 2 OF 15) AS NECESSARY, COMPLETE INSTALLATION OF AND ACTIVATE TEMPORARY SIGNAL 05-1027T1, THEN BEGIN CONSTRUCTION OF TEMPORARY PAVEMENT IN THE FOLLOWING LOCATIONS: (SEE SHEETS TMP-6 - TMP-8)

- -LALT- FROM STA. 36+71 +/- TO STA. 40+62 +/- (RT)
- -LALT- FROM STA. 47+36 +/- TO STA. 66+10 +/- (LT)

AWAY FROM TRAFFIC AND USING FLAGGERS, LANE CLOSURES (RSD 1101.02, SHEETS 1 AND 2 OF 15), AND TEMPORARY CLOSURES OF -Y7- (MORNING GLORY AVENUE), -Y9- (WORTH STREET), AND -Y11- (FRANKLIN STREET) AS NECESSARY, BEGIN INSTALLATION OF PROPOSED DRAINAGE SYSTEM (PIPES AND STRUCTURES) FROM DRAINAGE STRUCTURE NO. 801 TO DRAINAGE STRUCTURE NO. 1018 (SEE ROADWAY PLAN SHEETS 8 - 10). WHEN NEEDED, CONSTRUCT A TEMPORARY DRAINAGE STRUCTURE AND TIE THE PROPOSED SYSTEM AND 54" RCP TO THE EXISTING SYSTEM WITHIN FRANKLIN STREET (SEE SHEET TMP-7). MAINTAIN THIS TEMPORARY DRAINAGE PATTERN UNTIL COMPLETION OF THE PERMANENT DRAINAGE SYSTEM FROM DRAINAGE STRUCTURE NO. 901 TO DRAINAGE STRUCTURE NO. 1018 AND THE DRAINAGE SYSTEM WITHIN -Y15- (TAYLOR STREET). COVER TEMPORARY AND PROPOSED DRAINAGE STRUCTURES WITH TEMPORARY STEEL PLATES AS NECESSARY. USE DETOUR SHEETS TMP-2P AND TMP-2Q FOR ROAD CLOSURES. REOPEN ROADS UPON COMPLETION OF WORK AT EACH LOCATION.

USING RSD 1101.03, SHEET 1 OF 9, CLOSE AND DETOUR -Y16- (HOPKINS STREET), THEN AWAY FROM TRAFFIC AND USING FLAGGERS AND LANE CLOSURES (RSD 1101.01, SHEETS 1 AND 2 OF 15) AS NECESSARY, BEGIN CONSTRUCTION OF -Y16- FROM STA. 10+60 +/- TO STA. 11+85 +/- (PERMANENT PAVEMENT) AND -Y16- FROM STA. 10+35 +/- TO STA. 10+60 +/- (TEMPORARY PAVEMENT). (SEE SHEET TMP-8 AND LOCAL NOTE LN-06. SEE SHEET TMP-2S FOR DETOUR ROUTE.)

THE CONTRACTOR MAY CONDUCT WORK IN PHASE 1, STEP 3A CONCURRENTLY WITH PHASE 1, STEPS 3 - 4 AND/OR 5 - 8. PHASE 1, STEP 3A MAY NOT BE COMPLETED CONCURRENTLY WITH PHASE 1, STEP 2 OR STEP 4A.

STEP 3A:

USING A ONE (1) NIGHT ROAD CLOSURE, DETOUR EXISTING NC 55 AND COMPLETE 42" RCP DRAINAGE SYSTEM CROSS PIPE INSTALLATION, INCLUDING INSTALLATION OF DRAINAGE STRUCTURE NO. 0803 AND NO. 0835 AT -LALT- STA. 38+75 +/- . COVER DRAINAGE STRUCTURES WITH TEMPORARY STEEL PLATES AND REPAIR THE EXISTING ROADWAY. UPON COMPLETION, REOPEN NC 55 TO THE EXISTING PATTERN. (SEE SHEET TMP-2E FOR DETOUR ROUTE.)

USING A ONE (1) NIGHT ROAD CLOSURE, DETOUR EXISTING NC 55 AND COMPLETE 30" RCP DRAINAGE SYSTEM CROSS PIPE INSTALLATION, INCLUDING INSTALLATION OF DRAINAGE STRUCTURE NO. 1003 AT -LALT- STA. 48+58 +/- . COVER DRAINAGE STRUCTURES WITH TEMPORARY STEEL PLATES AND REPAIR THE EXISTING ROADWAY. UPON COMPLETION, REOPEN NC 55 TO THE EXISTING PATTERN. (SEE SHEET TMP-2E FOR DETOUR ROUTE.)

STEP 4:

USING FLAGGERS AND LANE CLOSURES (RSD 1101.02, SHEETS 2 AND 3 OF 15) AND LAW ENFORCEMENT AS NECESSARY, PLACE ANCHORED PCB FROM -LALT- STA. 14+90 +/- TO STA. 18+70 +/-, THEN AWAY FROM TRAFFIC BEGIN CONSTRUCTION OF THE FOLLOWING: (SEE SHEET TMP-5)

- -LALT- STA. 15+00 +/- TO STA. 18+55 +/-, INCLUDING THE FOLLOWING:
 - > INSTALLATION OF SHORING NO. 1 AND NO. 2
 - > REMOVAL OF THE WEST SIDE OF THE EXISTING NC 55 BRIDGE OVER -YA- (NC 147) (SEE LOCAL NOTE LN-01)
 - > STAGE 1 OF THE NEW -LALT- BRIDGE OVER -YA- (SEE LOCAL NOTE LN-01)
 - > TEMPORARY PAVEMENT (-LALT- STA. 14+58 +/- TO STA. 15+35 +/-, AND -LALT- STA. 17+63 +/- TO STA. 18+41 +/-) (SEE LOCAL NOTE LN-01)
- -R3- STA. 10+07 +/- TO STA. 10+90 +/-

USING FLAGGERS AND LANE CLOSURES (RSD 1101.02, SHEET 2 OF 15), IN CONJUNCTION WITH TEMPORARY WIDENING WORK IN EACH AREA, BEGIN ASPHALT WEDGING IN THE FOLLOWING LOCATIONS TO CREATE A SMOOTH TRANSITION ALONG AND ACROSS TRAVEL LANES FROM THE EXISTING PAVEMENT TO THE TEMPORARY PAVEMENT WIDENING: (SEE SHEETS TMP-6 - TMP-8)

- -LALT- FROM STA. 39+50 +/- TO STA. 40+62 +/- (RT)
- -LALT- FROM STA. 47+75 +/- TO STA. 50+00 +/- (LT)
- -LALT- FROM STA. 61+75 +/- TO STA. 66+10 +/- (LT)

THE CONTRACTOR MAY CONDUCT WORK IN PHASE 1, STEP 4A CONCURRENTLY WITH PHASE 1, STEPS 3 - 4 AND/OR 5 - 10. PHASE 1, STEP 4A MAY NOT BE COMPLETED CONCURRENTLY WITH PHASE 1, STEP 2 OR STEP 4A, AND AS NOTED IN LOCAL NOTE LN-01 (SEE SHEET TMP-2A).

THE CONTRACTOR SHALL COMPLETE THE WORK REQUIRED IN PHASE 1, STEP 4A IN THIRTY (30) CONSECUTIVE DAYS. (SEE INTERMEDIATE CONTRACT TIME AND LIQUIDATED DAMAGES)

STEP 4A:

WORKING IN A CONTINUOUS MANNER, AWAY FROM TRAFFIC AND USING FLAGGERS, LANE CLOSURES (RSD 1101.02, SHEETS 1 AND 2 OF 15) AND LAW ENFORCEMENT AS NECESSARY, INSTALL AND ACTIVATE TEMPORARY SIGNAL 05-1028T1A, THEN CLOSE AND DETOUR -R1-. (SEE SHEET TMP-2G FOR DETOUR ROUTE)

UPON CLOSURE OF -R1-, AWAY FROM TRAFFIC AND USING FLAGGERS AND LANE CLOSURES (RSD 1101.02, SHEETS 1 AND 2 OF 15) AS NECESSARY, COMPLETE RECONSTRUCTION OF -R1-, INCLUDING COMPLETION OF -LALT- FROM STA. 13+50 +/- TO STA. 15+00 +/- (LT). IN CONJUNCTION WITH -LALT- AND -R1- WORK, PLACE ASPHALT WEDGING IN THE -LALT-/-R1- INTERSECTION TO PROVIDE A SMOOTH TRANSITION ALONG AND ACROSS TRAVEL LANES FROM THE EXISTING PAVEMENT TO THE NEW PAVEMENT AND TEMPORARY PAVEMENT WIDENING. (SEE SHEET TMP-5A)

UPON COMPLETION OF -R1- AND ASSOCIATED -LALT- WORK, WORKING IN A CONTINUOUS MANNER AWAY FROM TRAFFIC AND USING FLAGGERS, LANE CLOSURES (RSD 1101.02, SHEETS 1 AND 2 OF 15), AND LAW ENFORCEMENT AS NECESSARY, INSTALL AND ACTIVATE TEMPORARY SIGNAL 05-10284T1B, PLACE TEMPORARY MARKINGS IN THE FINAL PATTERN ON -R1- (AS SHOWN ON SHEET TMP-9), THEN REMOVE THE DETOUR AND REOPEN -R1- TO THE TEMPORARY PATTERN.

APPROVED:  DATE: 5/13/2016

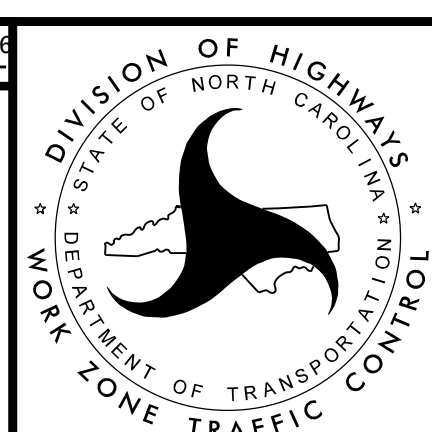

PHASING

DOCUMENT NOT CONSIDERED FINAL UNLESS ALL SIGNATURES COMPLETED

PLOT DRIVER: NCDOT_pdf_color_eng_50.ppt
USER: erbrooks
FILE: c:\pwworking\paw\d0487729\U-3308_TMP-TMP-03.dgn
PENTABLE: NCDOT_tcp.tbl
DATE: 5/13/2016
TIME: 9:47:27 AM

REVISIONS

PROJ. REFERENCE NO.	SHEET NO.
U-3308	TMP-3A
 HDR Engineering, Inc. of the Carolinas 3733 National Drive, Suite 207 Raleigh, N.C. 27612 N.C.B.E.L.S. License Number: F-0116	

PHASING

PHASE 1 (CONTINUED)

THE CONTRACTOR MAY CONDUCT WORK IN PHASE 1, STEP 5 CONCURRENTLY WITH PHASE 1, STEPS 2 - 4, 4A, AND/OR 6 - 10.

THE CONTRACTOR SHALL COMPLETE THE WORK REQUIRED IN PHASE 1, STEP 5 IN THIRTY (30) CONSECUTIVE DAYS. (SEE INTERMEDIATE CONTRACT TIME AND LIQUIDATED DAMAGES)

STEP 5:

WORKING IN A CONTINUOUS MANNER, AWAY FROM TRAFFIC AND USING FLAGGERS, LANE CLOSURES (RSD 1101.02, SHEETS 1, 2, AND 7 OF 15, AND RSD 1101.04) AND LAW ENFORCEMENT AS NECESSARY, INSTALL AND ACTIVATE TEMPORARY SIGNAL 05-0284T2, THEN USING RSD 1101.03, SHEET 1 OF 9, CLOSE AND DETOUR -Y3- (GANN STREET). (SEE SHEET TMP-2I FOR DETOUR ROUTE)

UPON CLOSURE OF -Y3-, AWAY FROM TRAFFIC AND USING FLAGGERS AND LANE CLOSURES (RSD 1101.02, SHEETS 1 AND 2 OF 15) AS NECESSARY, COMPLETE RECONSTRUCTION OF -Y3-, INCLUDING COMPLETION OF -LALT- FROM STA. 19+98 +/- TO STA. 20+94 +/- (LT). IN CONJUNCTION WITH -LALT- WORK, PLACE TEMPORARY WEDGING OVER THE PROPOSED -LALT- PAVEMENT AND CONSTRUCT TEMPORARY PAVEMENT (-LALT- STA. 19+98 +/- TO STA. 20+94 +/-) TO PROVIDE A CONNECTION FROM EXISTING NC 55 PAVEMENT TO THE NEW -LALT- PAVEMENT AND -Y3- INTERSECTION. (SEE SHEET TMP-5)

UPON COMPLETION OF -Y3- AND ASSOCIATED -LALT- WORK, WORKING IN A CONTINUOUS MANNER AWAY FROM TRAFFIC AND USING FLAGGERS, LANE CLOSURES (RSD 1101.02, SHEETS 1 AND 2 OF 15), AND LAW ENFORCEMENT AS NECESSARY, INSTALL AND ACTIVATE TEMPORARY SIGNAL 05-0284T3, PLACE TEMPORARY MARKINGS ON -Y3- (AS SHOWN ON SHEET TMP-5A), THEN REMOVE THE DETOUR AND REOPEN -Y3- TO THE TEMPORARY PATTERN.

THE CONTRACTOR MAY CONDUCT WORK IN PHASE 1, STEP 6 CONCURRENTLY WITH PHASE 1, STEPS 2 - 5, 7 - 9, 11 - 12, AND/OR 16-21. AS DIRECTED BY OR UPON APPROVAL OF THE ENGINEER, PHASE 1, STEP 6 MAY BE COMBINED WITH PHASE 1, STEP 15. PHASE 1, STEP 6 MAY NOT BE COMPLETED CONCURRENTLY WITH PHASE 1, STEP 10.

THE CONTRACTOR SHALL COMPLETE THE WORK REQUIRED IN PHASE 1, STEP 6 IN SIXTY (60) CONSECUTIVE DAYS. (SEE INTERMEDIATE CONTRACT TIME AND LIQUIDATED DAMAGES) NO WORK MAY OCCUR ALONG -Y15- (TAYLOR STREET) DURING ACTIVE SCHOOL DAYS. (SEE LOCAL NOTE LN-04, SHEET TMP-2A)

STEP 6:

WORKING IN A CONTINUOUS MANNER, AWAY FROM TRAFFIC AND USING FLAGGERS, LANE CLOSURES (RSD 1101.02, SHEETS 1, 2, AND 7 OF 15, AND RSD 1101.04) AND LAW ENFORCEMENT AS NECESSARY, COMPLETE INSTALLATION OF AND ACTIVATE TEMPORARY SIGNAL 05-0228T1, THEN USING RSD 1101.03, SHEET 1 OF 9, CLOSE AND DETOUR -Y15- (TAYLOR STREET). (SEE SHEET TMP-2R FOR DETOUR ROUTE)

UPON CLOSURE OF -Y15-, AWAY FROM TRAFFIC AND USING FLAGGERS AND LANE CLOSURES (RSD 1101.02, SHEETS 1 AND 2 OF 15) AS NECESSARY, COMPLETE RECONSTRUCTION OF -Y15- FROM STA. 10+75 +/- TO STA. 16+40 +/-, -Y15A-, AND TEMPORARY PAVEMENT FROM -Y15- STA. 10+05 +/- TO STA. 10+75 +/- . BEGIN CONSTRUCTION OF RETAINING WALL #2, COMPLETING AS NECESSARY WITH ASSOCIATED -Y15- WORK. (SEE SHEET TMP-7)

UPON COMPLETION OF -Y15-, WORKING IN A CONTINUOUS MANNER AWAY FROM TRAFFIC AND USING FLAGGERS, LANE CLOSURES (RSD 1101.02, SHEET 2 OF 15), AND LAW ENFORCEMENT AS NECESSARY, INSTALL AND ACTIVATE TEMPORARY SIGNAL 05-0228T2, PLACE TEMPORARY MARKINGS ON -Y15- (AS SHOWN ON SHEET TMP-11), THEN REMOVE THE DETOUR AND REOPEN -Y15- TO THE TEMPORARY PATTERN.

THE CONTRACTOR MAY CONDUCT WORK IN PHASE 1, STEP 7 CONCURRENTLY WITH PHASE 1, STEPS 2 - 6 AND/OR 8 - 10.

THE CONTRACTOR SHALL COMPLETE THE WORK REQUIRED IN PHASE 1, STEP 7 IN SIXTY (60) CONSECUTIVE DAYS. (SEE INTERMEDIATE CONTRACT TIME AND LIQUIDATED DAMAGES)

STEP 7:

WORKING IN A CONTINUOUS MANNER, AWAY FROM TRAFFIC AND USING FLAGGERS, LANE CLOSURES (RSD 1101.02, SHEETS 1, 2, AND 7 OF 15, AND RSD 1101.04) AND LAW ENFORCEMENT AS NECESSARY, COMPLETE INSTALLATION OF AND ACTIVATE TEMPORARY SIGNAL 05-1029T1, THEN USING RSD 1101.03, SHEET 1 OF 9, CLOSE AND DETOUR -Y18- (LIBERTY STREET). (SEE SHEET TMP-2S FOR DETOUR ROUTE)

UPON CLOSURE OF -Y18-, AWAY FROM TRAFFIC AND USING FLAGGERS AND LANE CLOSURES (RSD 1101.02, SHEETS 1 AND 2 OF 15) AS NECESSARY, COMPLETE RECONSTRUCTION OF -Y18- FROM STA. 10+20 +/- TO STA. 13+10 +/- AND TEMPORARY PAVEMENT FROM -Y18- STA. 13+10 +/- TO STA. 13+45 +/-, INCLUDING COMPLETION OF TEMPORARY PAVEMENT ON -LALT- FROM STA. 56+70 +/- TO STA. 57+75 +/- (LT). (SEE SHEET TMP-8)

UPON COMPLETION OF -Y18-, WORKING IN A CONTINUOUS MANNER AWAY FROM TRAFFIC AND USING FLAGGERS, LANE CLOSURES (RSD 1101.02, SHEET 2 OF 15), AND LAW ENFORCEMENT AS NECESSARY, INSTALL AND ACTIVATE TEMPORARY SIGNAL 05-1029T2, PLACE TEMPORARY MARKINGS ON -Y18- (AS SHOWN ON SHEET TMP-12), THEN REMOVE THE DETOUR AND REOPEN -Y18- TO THE TEMPORARY PATTERN.

STEP 8:

AWAY FROM TRAFFIC AND USING FLAGGERS, LANE CLOSURES, AND SHOULDER CLOSURES (RSD 1101.02, SHEETS 1, 2, 3, AND 7 OF 15, AND RSD 1101.04) AND LAW ENFORCEMENT AS NECESSARY, BEGIN INSTALLATION OF TEMPORARY SIGNALS 05-0228T3, 05-1026T2, 05-1027T2, 05-1029T3.

COMPLETE CONSTRUCTION OF PERMANENT PAVEMENT, TEMPORARY PAVEMENT, AND TEMPORARY WEDGING BEGUN EARLIER IN THE FOLLOWING LOCATIONS: (SEE SHEETS TMP-6 - TMP-8)

- -Y1- FROM STA. 11+00 +/- TO STA. 12+41 +/- (PERMANENT)
- -LALT- FROM STA. 31+00 +/- TO STA. 32+00 +/- (LT) (PERMANENT), INCLUDING TEMPORARY TIE TO EXISTING NC 55
- -LALT- FROM STA. 36+71 +/- TO STA. 40+62 +/- (RT) (TEMPORARY)
- -LALT- FROM STA. 47+36 +/- TO STA. 66+10 +/- (LT) (TEMPORARY)
- -Y16- FROM STA. 10+35 +/- TO STA. 10+60 +/- (TEMPORARY)
- -Y16- FROM STA. 10+60 +/- TO STA. 11+85 +/- (PERMANENT)

COMPLETE TRACK CONSTRUCTION OF THE CSX RAIL AND RAIL DETOUR LINES, AND THE CSX RAIL BRIDGE OVER -LALT- BEGUN EARLIER.

COMPLETE PHASE 1, STEPS 9 - 10 CONCURRENTLY. UPON COMPLETION OF PHASE 1, STEPS 9 - 10, PROCEED DIRECTLY TO PHASE 1, STEP 11.

STEP 9:

WORKING IN A CONTINUOUS MANNER, AWAY FROM TRAFFIC AND USING FLAGGERS AND LANE CLOSURES (RSD 1101.02, SHEETS 1 AND 2 OF 15) AND LAW ENFORCEMENT AS NECESSARY, COMPLETE INSTALLATION OF AND ACTIVATE TEMPORARY SIGNALS 05-0228T3, 05-1027T2, 05-1029T3, AND 05-1030T1, PLACE TEMPORARY PAVEMENT MARKINGS IN THE TEMPORARY PATTERN AS SHOWN ON SHEETS TMP-9 - TMP-12, REMOVE DETOUR ON -Y16-, THEN SHIFT TRAFFIC TO THE PHASE 1, STEP 11 PATTERN IN THE FOLLOWING LOCATIONS:

- -LALT- FROM STA. 36+71 +/- TO STA. 42+14 +/-
- -LALT- FROM STA. 45+50 +/- TO STA. 67+60 +/-
- -Y22-

UPON COMPLETION OF -Y1- AND ASSOCIATED -LALT- WORK, WORKING IN A CONTINUOUS MANNER AWAY FROM TRAFFIC AND USING FLAGGERS, LANE CLOSURES (RSD 1101.02, SHEETS 1 AND 2 OF 15), AND LAW ENFORCEMENT AS NECESSARY, INSTALL AND ACTIVATE TEMPORARY SIGNAL 05-1026T2, PLACE TEMPORARY MARKINGS ON -Y1- (AS SHOWN ON SHEET TMP-10), THEN REMOVE THE DETOUR AND REOPEN -Y1- TO THE TEMPORARY PATTERN.

SHIFT ALL RAIL TRAFFIC TO THE RAIL DETOUR ALIGNMENT.

THE CONTRACTOR SHALL COMPLETE THE WORK REQUIRED IN PHASE 1, STEP 10 DURING A WEEKEND OPERATION. (SEE INTERMEDIATE CONTRACT TIME AND LIQUIDATED DAMAGES)

STEP 10:

CONDUCT WORK IN THE FOLLOWING ORDER FOR WORK ASSOCIATED WITH THE 72" RCP CROSSING OF NC 55 AT -LALT- STA. 52+50: (SEE SHEET TMP-7)

1. USING RSD 1101.03, SHEET 1 OF 9, DETOUR AND CLOSE EXISTING NC 55 (SEE SHEET TMP-2E FOR DETOUR ROUTE).
2. COMPLETE INSTALLATION OF NEW 72" RCP AND ADJACENT 30" RCP CROSSING. (SEE CUT SECTION E1-E1 AND FURTHER PHASING FOR PIPE INSTALLATION ON SHEET TMP-4C)
3. BACKFILL AND REPAIR EXISTING NC 55 WITH TEMPORARY PAVEMENT.
4. PLACE PORTABLE CONCRETE BARRIER (PCB) AND TEMPORARY PAVEMENT MARKINGS ALONG NC 55 (AS SHOWN ON SHEET TMP-11).
5. REMOVE THE DETOUR AND REOPEN NC 55 TO THE PHASE 1, STEP 11 PATTERN.

PHASE 1 (SHEETS TMP-9 - TMP-14)

STEP 11:

INSTALL PEDESTRIAN DETOUR SIGNING FOR CLOSURE OF THE SIDEWALK ON EXISTING NC 55 FROM MAIN STREET TO HOLLOWAY STREET. (SEE SHEET TMP-2Y FOR PEDESTRIAN DETOUR ROUTE)

USING RSD 1101.03, SHEET 1 OF 9, CLOSE AND DETOUR -Y- (PETTIGREW STREET), THEN AWAY FROM TRAFFIC, USING FLAGGERS AND LANE CLOSURES (RSD 1101.02, SHEET 1 OF 15) AND BY STOPPING TRAFFIC AS PERMITTED (RSD 1101.03, SHEET 8 OF 9), REMOVE THE OVERHEAD COMPONENTS AND PIERS OF THE PETTIGREW STREET BRIDGE OVER -LALT- (NC 55). (SEE LOCAL NOTE LN-02) (SEE SHEET TMP-2J FOR DETOUR ROUTE.)

AWAY FROM TRAFFIC, USING FLAGGERS AND LANE CLOSURES (RSD 1101.02, SHEET 1 OF 15) AND BY STOPPING TRAFFIC AS PERMITTED (RSD 1101.03, SHEET 8 OF 9), REMOVE THE OVERHEAD COMPONENTS AND PIERS OF THE EXISTING NORFOLK SOUTHERN RAILROAD (NSRR) BRIDGE OVER -LALT- (NC 55). (SEE LOCAL NOTE LN-02)

AWAY FROM TRAFFIC, BEGIN TRACK CONSTRUCTION OF THE NSRR LINES.

AWAY FROM TRAFFIC AND USING FLAGGERS, LANE CLOSURES, AND SHOULDER CLOSURES (RSD 1101.02, SHEETS 1, 2, 3, AND 7 OF 15, AND RSD 1101.04) AND LAW ENFORCEMENT AS NECESSARY, BEGIN INSTALLATION OF TEMPORARY SIGNALS 05-0228T4, 05-1027T3, 05-1029T4, AND 05-1030T2.

AWAY FROM TRAFFIC AND USING FLAGGERS AND LANE CLOSURES (RSD 1101.01, SHEETS 1 OF 15) AS NECESSARY, BEGIN CONSTRUCTION OF THE FOLLOWING:

- -Y- FROM STA. 11+50 +/- TO STA. 15+10 +/-
- -Y3A-

AWAY FROM TRAFFIC, BEGIN CONSTRUCTION OF THE FOLLOWING:



- -Y- FROM STA. 15+10 +/- TO STA. 16+27 +/-
- -Y- FROM STA. 17+85 +/- TO STA. 25+00 +/-

AWAY FROM TRAFFIC AND USING FLAGGERS AND LANE CLOSURES (RSD 1101.01, SHEETS 1 AND 2 OF 15) AS NECESSARY, BEGIN CONSTRUCTION OF THE FOLLOWING:

- -LALT- FROM STA. 20+94 +/- TO STA. 24+39 +/- (LT) (PERMANENT)
- -LALT- FROM STA. 37+40 +/- TO STA. 39+25 +/- (LT) (PERMANENT)
- -LALT- FROM STA. 38+66 +/- TO STA. 39+25 +/- (LT) (TEMPORARY)
- -LALT- FROM STA. 39+25 +/- TO STA. 40+56 +/- (LT) (TEMPORARY)
- -LALT- FROM STA. 39+25 +/- TO STA. 40+32 +/- (LT) (WEDGING)
- RETAINING WALL #1 (-LALT- STA. 37+32 +/- TO STA. 40+30 +/-)

REVISIONS

PLOT DRIVER: NCD07.pdf_color_eng_50.ppt
 USER: erbrooks
 FILE: c:\pwworking\pa\d0487729\U-3308_TMP-TMP-03.dgn
 PENTABLE: NCD07_tcp.tbl
 DATE: 5/12/2016
 TIME: 3:58:11 PM

APPROVED  DATE: 5/13/2016			PHASING
SEAL			

DOCUMENT NOT CONSIDERED FINAL
UNLESS ALL SIGNATURES COMPLETED

PROJ. REFERENCE NO.	SHEET NO.
U-3308	TMP-3B
 HDR Engineering, Inc. of the Carolinas 3733 National Drive, Suite 207 Raleigh, N.C. 27612 N.C.B.E.L.S. License Number: F-0116	

PHASING

STEP 11 (CONTINUED):

USING RSD 1101.03, SHEET 1 OF 9, CLOSE AND DETOUR -Y9- (WORTH STREET) AND -Y11- (FRANKLIN STREET), THEN AWAY FROM TRAFFIC AND USING FLAGGERS AND LANE CLOSURES (RSD 1101.01, SHEET 2 OF 15) AS NECESSARY, BEGIN CONSTRUCTION OF THE FOLLOWING: (SEE SHEET TMP-11) (SEE SHEET TMP-2Q FOR DETOUR ROUTE.)

- -Y9-
- -Y11-
- -LALT- FROM STA. 41+50 +/- TO STA. 48+25 +/- (RT), INCLUDING TEMPORARY PAVEMENT AND TEMPORARY WEDGING AT THE EXISTING -Y9- INTERSECTION (STA. 42+55 +/- TO STA. 43+20 +/-) AND EXISTING -Y11- INTERSECTION (STA. 44+30 +/- TO STA. 46+30 +/-) TO PROVIDE A CONNECTION FROM EXISTING NC 55 PAVEMENT TO THE NEW -LALT- PAVEMENT AND -Y9- AND -Y11- INTERSECTIONS.
- -LALT- FROM STA. 43+25 +/- TO STA. 48+25 +/- (LT) (WEDGING)

AWAY FROM TRAFFIC AND USING FLAGGERS AND LANE CLOSURES (RSD 1101.01, SHEETS 1 AND 2 OF 15) AS NECESSARY, BEGIN CONSTRUCTION OF THE FOLLOWING:

- -LALT- FROM STA. 49+30 +/- TO STA. 53+88 +/- (RT), INCLUDING TEMP PAVEMENT FROM STA. 50+84 +/- TO STA. 51+75 +/-
- -LALT- FROM STA. 54+62 +/- TO STA. 56+70 +/- (RT)
- -LALT- FROM STA. 64+25 +/- TO STA. 66+10 +/- (RT), INCLUDING TEMP PAVEMENT FROM STA. 64+25 +/- TO STA. 65+10 +/-

WHILE MAINTAINING ACCESS TO -Y21- (EVA STREET), AND USING FLAGGERS AND LANE CLOSURES (RSD 1101.01, SHEET 1 OF 15) AS NECESSARY, INSTALL PCB FROM -LALT- STA. 59+75 +/- TO STA. 61+95 +/-, THEN INSTALL SHORING NO. 3.

USING A ONE (1) NIGHT ROAD CLOSURE, DETOUR EXISTING NC 55 AND COMPLETE 48" RCP DRAINAGE SYSTEM CROSS PIPE INSTALLATION, INCLUDING INSTALLATION OF DRAINAGE STRUCTURE NO. 0827 AND NO. 0834 AT -LALT- STA. 42+50 +/- . COVER DRAINAGE STRUCTURES WITH TEMPORARY STEEL PLATES AND REPAIR THE EXISTING ROADWAY. UPON COMPLETION, REOPEN NC 55 TO THE EXISTING PATTERN. (SEE SHEET TMP-2E FOR DETOUR ROUTE.)

USING A ONE (1) NIGHT ROAD CLOSURE, DETOUR EXISTING NC 55 AND COMPLETE 42" RCP DRAINAGE SYSTEM CROSS PIPE INSTALLATION, INCLUDING INSTALLATION OF DRAINAGE STRUCTURE NO. 1309 AT -LALT- STA. 65+40 +/- . COVER DRAINAGE STRUCTURES WITH TEMPORARY STEEL PLATES AND REPAIR THE EXISTING ROADWAY. UPON COMPLETION, REOPEN NC 55 TO THE EXISTING PATTERN. (SEE SHEET TMP-2F FOR DETOUR ROUTE.)

STEP 12:

AWAY FROM TRAFFIC, USING FLAGGERS AND LANE CLOSURES (RSD 1101.02, SHEET 1 OF 15) AND BY STOPPING TRAFFIC AS PERMITTED (RSD 1101.03, SHEET 8 OF 9), BEGIN CONSTRUCTION OF THE -Y- (PETTIGREW STREET) BRIDGE OVER -LALT-. (SEE SHEET TMP-9 AND LOCAL NOTE LN-02)

AWAY FROM TRAFFIC, USING FLAGGERS AND LANE CLOSURES (RSD 1101.02, SHEET 1 OF 15) AND BY STOPPING TRAFFIC AS PERMITTED (RSD 1101.03, SHEET 8 OF 9), BEGIN CONSTRUCTION OF THE NSRR BRIDGE OVER -LALT-. (SEE SHEET TMP-9 AND LOCAL NOTE LN-02)

AWAY FROM TRAFFIC AND USING FLAGGERS AND LANE CLOSURES (RSD 1101.01, SHEETS 1 AND 2 OF 15) AS NECESSARY, BEGIN CONSTRUCTION OF THE FOLLOWING:

- -LALT- FROM STA. 57+75 +/- TO STA. 63+30 +/- (RT), INCLUDING TEMPORARY PAVEMENT FROM STA. 59+11 +/- TO STA. 60+25 +/-
- -Y21-

NOTE - MAINTAIN ACCESS TO -Y21- (EVA STREET) THROUGH THE WORK AREA DURING CONSTRUCTION.

THE CONTRACTOR MAY CONDUCT WORK IN PHASE 1, STEP 13 CONCURRENTLY WITH PHASE 1, STEPS 11, 12, 14 AND/OR 17 - 21. PHASE 1, STEP 13 MAY NOT BE COMPLETED CONCURRENTLY WITH PHASE 1, STEPS 15 - 16.

THE CONTRACTOR SHALL COMPLETE THE WORK REQUIRED IN PHASE 1, STEP 13 IN FOURTEEN (14) CONSECUTIVE DAYS. (SEE INTERMEDIATE CONTRACT TIME AND LIQUIDATED DAMAGES) NO WORK MAY OCCUR ALONG -Y17- (HOPKINS STREET) DURING ACTIVE SCHOOL DAYS. (SEE LOCAL NOTE LN-04, SHEET TMP-2A)

STEP 13:

USING RSD 1101.03, SHEET 1 OF 9, CLOSE AND DETOUR -Y17- (HOPKINS STREET) (SEE SHEET TMP-2T FOR DETOUR ROUTE), THEN AWAY FROM TRAFFIC AND USING FLAGGERS AND LANE CLOSURES (RSD 1101.02, SHEETS 1 AND 2 OF 15) AS NECESSARY, COMPLETE RECONSTRUCTION OF -Y17-, INCLUDING COMPLETION OF -LALT- FROM STA. 53+88 +/- TO STA. 54+62 +/- (RT). IN CONJUNCTION WITH -LALT- WORK, CONSTRUCT TEMPORARY PAVEMENT (-LALT- STA. 53+70 +/- TO STA. 54+70 +/-, AND -LALT- STA. 54+30 +/- TO STA. 54+62 +/- [IN FUTURE BULB-OUT]) TO PROVIDE A CONNECTION FROM EXISTING NC 55 PAVEMENT TO THE NEW -LALT- PAVEMENT AND -Y17- INTERSECTION. (SEE SHEET TMP-12)

UPON COMPLETION OF -Y17- AND ASSOCIATED -LALT- WORK, PLACE TEMPORARY MARKINGS ON -Y17- (AS SHOWN ON SHEET TMP-14), THEN REMOVE THE DETOUR AND REOPEN -Y17- TO THE TEMPORARY PATTERN.

THE CONTRACTOR MAY CONDUCT WORK IN PHASE 1, STEP 14 CONCURRENTLY WITH PHASE 1, STEPS 11 - 13 AND/OR 17 - 21. PHASE 1, STEP 14 MAY NOT BE COMPLETED CONCURRENTLY WITH PHASE 1, STEPS 15 - 16.

THE CONTRACTOR SHALL COMPLETE THE WORK REQUIRED IN PHASE 1, STEP 14 IN SIXTY (60) CONSECUTIVE DAYS. (SEE INTERMEDIATE CONTRACT TIME AND LIQUIDATED DAMAGES)

STEP 14:

WORKING IN A CONTINUOUS MANNER, AWAY FROM TRAFFIC AND USING FLAGGERS AND LANE CLOSURES (RSD 1101.02, SHEETS 1 AND 2 OF 15) AND LAW ENFORCEMENT AS NECESSARY, COMPLETE INSTALLATION OF AND ACTIVATE TEMPORARY SIGNAL 05-1029T4, THEN USING RSD 1101.03, SHEET 1 OF 9, CLOSE AND DETOUR -Y18- (LIBERTY STREET). (SEE SHEET TMP-2T FOR DETOUR ROUTE)

UPON CLOSURE OF -Y18-, AWAY FROM TRAFFIC AND USING FLAGGERS AND LANE CLOSURES (RSD 1101.02, SHEETS 1 AND 2 OF 15) AS NECESSARY, COMPLETE RECONSTRUCTION OF -Y18-, INCLUDING COMPLETION OF -LALT- FROM STA. 56+70 +/- TO STA. 57+75 +/- (RT). IN CONJUNCTION WITH -LALT- WORK, PLACE TEMPORARY WEDGING OVER THE PROPOSED -LALT- PAVEMENT AND CONSTRUCT TEMPORARY PAVEMENT (-LALT- STA. 56+70 +/- TO STA. 57+75 +/-, AND -LALT- STA. 57+36 +/- TO STA. 57+69 +/- [IN FUTURE BULB-OUT]) TO PROVIDE A CONNECTION FROM EXISTING NC 55 PAVEMENT TO THE NEW -LALT- PAVEMENT AND -Y18- INTERSECTION. (SEE SHEET TMP-12)

UPON COMPLETION OF -Y18- AND ASSOCIATED -LALT- WORK, WORKING IN A CONTINUOUS MANNER AWAY FROM TRAFFIC AND USING FLAGGERS, LANE CLOSURES (RSD 1101.02, SHEETS 1 AND 2 OF 15), AND LAW ENFORCEMENT AS NECESSARY, INSTALL AND ACTIVATE TEMPORARY SIGNAL 05-1029T5, PLACE TEMPORARY MARKINGS ON -Y18- (AS SHOWN ON SHEET TMP-14), THEN REMOVE THE DETOUR AND REOPEN -Y18- TO THE TEMPORARY PATTERN.

THE CONTRACTOR MAY CONDUCT WORK IN PHASE 1, STEP 15 CONCURRENTLY WITH PHASE 1, STEPS 11 - 12 AND/OR 16 - 21. AS DIRECTED BY OR UPON APPROVAL OF THE ENGINEER, PHASE 1, STEP 15 MAY BE COMBINED WITH PHASE 1, STEP 6. PHASE 1, STEP 15 MAY NOT BE COMPLETED CONCURRENTLY WITH PHASE 1, STEP 10 OR STEPS 13 - 14.

THE CONTRACTOR SHALL COMPLETE THE WORK REQUIRED IN PHASE 1, STEP 15 IN SEVEN (7) CONSECUTIVE DAYS. (SEE INTERMEDIATE CONTRACT TIME AND LIQUIDATED DAMAGES) NO WORK MAY OCCUR ALONG -Y15- (TAYLOR STREET) DURING ACTIVE SCHOOL DAYS. (SEE LOCAL NOTE LN-04, SHEET TMP-2A)

STEP 15:

WORKING IN A CONTINUOUS MANNER, AWAY FROM TRAFFIC AND USING FLAGGERS AND LANE CLOSURES (RSD 1101.02, SHEETS 1 AND 2 OF 15) AND LAW ENFORCEMENT AS NECESSARY, COMPLETE INSTALLATION OF AND ACTIVATE TEMPORARY SIGNAL 05-0228T4, THEN USING RSD 1101.03, SHEET 1 OF 9, CLOSE AND DETOUR -Y15- (TAYLOR STREET). (SEE SHEET TMP-2R FOR DETOUR ROUTE)

UPON CLOSURE OF -Y15-, AWAY FROM TRAFFIC AND USING FLAGGERS AND LANE CLOSURES (RSD 1101.02, SHEETS 1 AND 2 OF 15) AS NECESSARY, COMPLETE RECONSTRUCTION OF -Y15- FROM STA. 10+00 +/- TO STA. 10+75 +/-, INCLUDING COMPLETION OF -LALT- FROM STA. 48+25 +/- TO STA. 49+30 +/- (RT). IN CONJUNCTION WITH -LALT- WORK, PLACE TEMPORARY WEDGING OVER THE PROPOSED -LALT- PAVEMENT AND CONSTRUCT TEMPORARY PAVEMENT (-LALT- STA. 48+25 +/- TO STA. 49+30 +/-) TO PROVIDE A CONNECTION FROM EXISTING NC 55 PAVEMENT TO THE NEW -LALT- PAVEMENT AND -Y15- INTERSECTION. (SEE SHEET TMP-13)

UPON COMPLETION OF -Y15- AND ASSOCIATED -LALT- WORK, WORKING IN A CONTINUOUS MANNER AWAY FROM TRAFFIC AND USING FLAGGERS, LANE CLOSURES (RSD 1101.02, SHEETS 1 AND 2 OF 15), AND LAW ENFORCEMENT AS NECESSARY, INSTALL AND ACTIVATE TEMPORARY SIGNAL 05-0228T5, PLACE TEMPORARY MARKINGS ON -Y15- (AS SHOWN ON SHEET TMP-17), THEN REMOVE THE DETOUR AND REOPEN -Y15- TO THE TEMPORARY PATTERN.

THE CONTRACTOR MAY CONDUCT WORK IN PHASE 1, STEP 16 CONCURRENTLY WITH PHASE 1, STEPS 11 - 12, 15, AND/OR 17 - 20. PHASE 1, STEP 16 MAY NOT BE COMPLETED CONCURRENTLY WITH PHASE 1, STEPS 13, 14, OR 21.

THE CONTRACTOR SHALL COMPLETE THE WORK REQUIRED IN PHASE 1, STEP 16 IN THIRTY (30) CONSECUTIVE DAYS. (SEE INTERMEDIATE CONTRACT TIME AND LIQUIDATED DAMAGES)

STEP 16:

ADJUST PEDESTRIAN DETOUR SIGNING FOR CLOSURE OF THE SIDEWALK ON EXISTING NC 55 FROM MAIN STREET TO HOLLOWAY STREET (INSTALLED DURING PHASE 1, STEP 11) TO ROUTE PEDESTRIANS ALONG LIBERTY STREET DURING THE HOLLOWAY STREET CLOSURE. (SEE SHEET TMP-2Z FOR PEDESTRIAN DETOUR ROUTE)

WORKING IN A CONTINUOUS MANNER, AWAY FROM TRAFFIC AND USING FLAGGERS AND LANE CLOSURES (RSD 1101.02, SHEETS 1 AND 2 OF 15) AND LAW ENFORCEMENT AS NECESSARY, COMPLETE INSTALLATION OF AND ACTIVATE TEMPORARY SIGNAL 05-1027T3, THEN USING RSD 1101.03, SHEET 1 OF 9, CLOSE AND DETOUR -Y22- (HOLLOWAY STREET). (SEE SHEET TMP-2V FOR DETOUR ROUTE)

UPON CLOSURE OF -Y22-, AWAY FROM TRAFFIC AND USING FLAGGERS AND LANE CLOSURES (RSD 1101.02, SHEETS 1 AND 2 OF 15) AS NECESSARY, COMPLETE RECONSTRUCTION OF -Y22- FROM STA. 14+09 +/- TO STA. 18+40 +/-, INCLUDING COMPLETION OF -LALT- FROM STA. 63+30 +/- TO STA. 64+25 +/- (RT) AND TEMPORARY PAVEMENT FROM -LALT- STA. 63+94 +/- TO STA. 64+25 +/- . IN CONJUNCTION WITH -LALT- WORK, PLACE TEMPORARY WEDGING OVER THE EXISTING PAVEMENT (-LALT- STA. 62+50 +/- TO STA. 64+00 +/-) TO PROVIDE A CONNECTION FROM EXISTING NC 55 PAVEMENT TO THE NEW -LALT- PAVEMENT AND -Y22- INTERSECTION. (SEE SHEET TMP-14)

UPON COMPLETION OF -Y22- AND ASSOCIATED -LALT- WORK, WORKING IN A CONTINUOUS MANNER AWAY FROM TRAFFIC AND USING FLAGGERS, LANE CLOSURES (RSD 1101.02, SHEETS 1 AND 2 OF 15), AND LAW ENFORCEMENT AS NECESSARY, INSTALL AND ACTIVATE TEMPORARY SIGNAL 05-1027T4, PLACE TEMPORARY MARKINGS ON -Y22- (AS SHOWN ON SHEET TMP-18), THEN REMOVE THE DETOUR AND REOPEN -Y22- TO THE TEMPORARY PATTERN.

STEP 17:

AWAY FROM TRAFFIC AND USING FLAGGERS, LANE CLOSURES, AND SHOULDER CLOSURES (RSD 1101.02, SHEETS 1, 2, 3, AND 7 OF 15, AND RSD 1101.04) AND LAW ENFORCEMENT AS NECESSARY, BEGIN INSTALLATION OF TEMPORARY SIGNALS 05-0228T6, 05-0284T4, 05-1026T3, 05-1027T5, 05-1028T2, 05-1029T6, AND 05-1030T3.

COMPLETE CONSTRUCTION OF ALL PERMANENT PAVEMENT, TEMPORARY PAVEMENT, AND TEMPORARY WEDGING BEGUN EARLIER ON THE FOLLOWING LOCATIONS: (SEE SHEETS TMP-9 - TMP-12)

- -LALT- FROM STA. 13+20 +/- TO STA. 18+55 +/- (LT), INCLUDING -LALT- BRIDGE OVER -YA- (NC 147) (STAGE 1) (SEE LOCAL NOTE LN-01)
- -LALT- FROM STA. 20+94 +/- TO STA. 40+56 +/- (LT)
- -LALT- FROM STA. 41+50 +/- TO STA. 66+10 +/- (RT)
- -R1-
- -Y9-
- -Y11-
- -Y21-

APPROVED  DATE: 5/13/2016

SEAL 

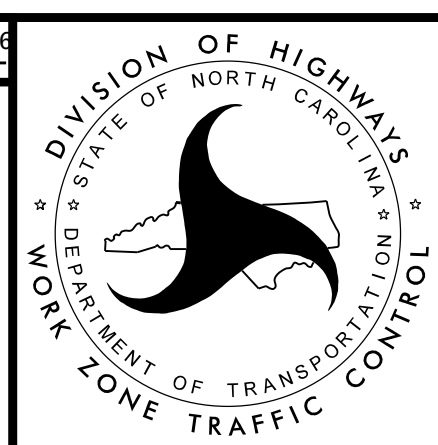

PHASING

DOCUMENT NOT CONSIDERED FINAL UNLESS ALL SIGNATURES COMPLETED

PROJ. REFERENCE NO.	SHEET NO.
U-3308	TMP-3C
 HDR Engineering, Inc. of the Carolinas 3733 National Drive, Suite 207 Raleigh, N.C. 27612 N.C.B.E.L.S. License Number: F-0116	

PHASING

PHASE 1 (CONTINUED)

COMPLETE PHASE 1, STEPS 18 - 21 CONCURRENTLY. UPON COMPLETION OF PHASE 1, STEPS 18 - 21, PROCEED DIRECTLY TO PHASE 2, STEP 1.

STEP 18:

WORKING IN A CONTINUOUS MANNER, AWAY FROM TRAFFIC AND USING FLAGGERS AND LANE CLOSURES (RSD 1101.02, SHEETS 1 AND 2 OF 15) AND LAW ENFORCEMENT AS NECESSARY, COMPLETE THE FOLLOWING IN THIS ORDER:

1. INSTALLATION AND ACTIVATION OF TEMPORARY SIGNALS 05-0228T6, 05-0284T4, 05-1026T3, 05-1027T5, 05-1028T2, AND 05-1029T6
2. INSTALL PCB IN THE FOLLOWING LOCATIONS: (SEE SHEETS TMP-15 - TMP-16)
 - -LALT- FROM STA. 14+90 +/- TO STA. 18+00 +/- (ANCHORED)
 - -LALT- FROM STA. 22+60 +/- TO STA. 24+80 +/-
 - -LALT- FROM STA. 36+00 +/- TO STA. 38+75 +/-
3. PLACE TEMPORARY PAVEMENT MARKINGS IN THE TEMPORARY PATTERN, AS SHOWN ON SHEETS TMP-15 - TMP-18. PLACE TEMPORARY MARKINGS IN THE FINAL PATTERN ON -R1- AS SHOWN ON SHEET TMP-15.
4. USING RSD 1101.03, SHEETS 1 AND 7 OF 9, CLOSE AND DETOUR -R4- AND -Y7-. (SEE SHEET TMP-2H AND TMP-2P FOR DETOUR ROUTES)
5. SHIFT TRAFFIC TO THE PHASE 2, STEP 1 PATTERN
6. REMOVE DETOURS AND REOPEN -Y9- AND -Y11-

THE CONTRACTOR MAY CONDUCT WORK IN PHASE 1, STEP 19 CONCURRENTLY WITH PHASE 1, STEPS 11 - 18, 20, AND/OR 21.

THE CONTRACTOR SHALL COMPLETE THE WORK REQUIRED IN PHASE 1, STEP 19 IN THIRTY (30) CONSECUTIVE DAYS. (SEE INTERMEDIATE CONTRACT TIME AND LIQUIDATED DAMAGES)

STEP 19:

USING RSD 1101.03, SHEET 1 OF 9, CLOSE AND DETOUR -R3- (SEE SHEET TMP-2H FOR DETOUR ROUTE), THEN AWAY FROM TRAFFIC AND USING FLAGGERS AND LANE CLOSURES (RSD 1101.02, SHEETS 1 AND 2 OF 15) AS NECESSARY, COMPLETE THE FOLLOWING: (SEE SHEET TMP-9)

- -LALT- FROM STA. 18+55 +/- TO STA. 19+98 +/-
- -R3- FROM STA. 10+90 +/- TO STA. 13+60 +/-

UPON COMPLETION OF -R3- AND ASSOCIATED -LALT- WORK, WORKING IN A CONTINUOUS MANNER AWAY FROM TRAFFIC AND USING FLAGGERS, LANE CLOSURES (RSD 1101.02, SHEETS 1 AND 2 OF 15), PLACE TEMPORARY MARKINGS AND OPEN -R3- TO THE PHASE 2, STEP 1 PATTERN.

THE CONTRACTOR MAY CONDUCT WORK IN PHASE 1, STEP 20 CONCURRENTLY WITH PHASE 1, STEPS 11 - 19 AND/OR 21.

THE CONTRACTOR SHALL COMPLETE THE WORK REQUIRED IN PHASE 1, STEP 20 IN THIRTY (30) CONSECUTIVE DAYS. (SEE INTERMEDIATE CONTRACT TIME AND LIQUIDATED DAMAGES)

STEP 20:

WORKING IN A CONTINUOUS MANNER, AWAY FROM TRAFFIC AND USING FLAGGERS, LANE CLOSURES (RSD 1101.02, SHEETS 1, 2, AND 7 OF 15, AND RSD 1101.04) AND LAW ENFORCEMENT AS NECESSARY, COMPLETE INSTALLATION OF AND ACTIVATE TEMPORARY SIGNAL 05-1030T2, THEN USING RSD 1101.03, SHEET 1 OF 9, CLOSE AND DETOUR -Y4- (E. MAIN STREET). (SEE SHEET TMP-2M FOR DETOUR ROUTE)

UPON CLOSURE OF -Y4-, AWAY FROM TRAFFIC AND USING FLAGGERS AND LANE CLOSURES (RSD 1101.02, SHEETS 1 AND 2 OF 15) AS NECESSARY, CONDUCT WORK IN THE FOLLOWING SEQUENCE: (SEE SHEET TMP-10)

1. PLACE PCB ALONG -LALT- FROM STA. 36+00 +/- TO STA. 38+75 +/-.
2. INSTALL SHORING NO. 4.
3. COMPLETE RECONSTRUCTION OF -Y4-, INCLUDING COMPLETION OF -LALT- FROM STA. 36+00 +/- TO STA. 37+40 +/-.

UPON COMPLETION OF -Y4- RECONSTRUCTION AND ASSOCIATED -LALT- WORK, WORKING IN A CONTINUOUS MANNER AWAY FROM TRAFFIC AND USING FLAGGERS, LANE CLOSURES (RSD 1101.02, SHEETS 1 AND 2 OF 15), AND LAW ENFORCEMENT AS NECESSARY, COMPLETE THE FOLLOWING AND PROCEED DIRECTLY TO PHASE 2, STEP 1:

- INSTALL AND ACTIVATE TEMPORARY SIGNAL 05-1030T3
- PLACE TEMPORARY MARKINGS ON -Y4- (AS SHOWN ON SHEET TMP-16)
- CLOSE AND DETOUR -Y5- (MAIN STREET) (SEE SHEET TMP-2M FOR DETOUR)
- SHIFT NC 55 TRAFFIC TO THE PHASE 2, STEP 1 PATTERN
- REMOVE DETOUR AND REOPEN -Y4- TO THE PHASE 2, STEP 1 PATTERN

THE CONTRACTOR MAY CONDUCT WORK IN PHASE 1, STEP 21 CONCURRENTLY WITH PHASE 1, STEPS 11 - 15 AND/OR 17 - 20. PHASE 1, STEP 21 MAY NOT BE COMPLETED CONCURRENTLY WITH PHASE 1, STEP 16.

THE CONTRACTOR SHALL COMPLETE THE WORK REQUIRED IN PHASE 1, STEP 21 DURING A WEEKEND OPERATION. (SEE INTERMEDIATE CONTRACT TIME AND LIQUIDATED DAMAGES)

STEP 21:

CLOSE AND DETOUR NC 55 (SEE SHEET TMP-2F FOR DETOUR ROUTE), THEN AWAY FROM TRAFFIC, COMPLETE RECONSTRUCTION OF -LALT- FROM STA. 64+25 +/- TO STA. 66+10 +/- (10' LT - 6' RT). (SEE SHEET TMP-14)

UPON COMPLETION OF -LALT-, PLACE TEMPORARY MARKINGS AND REOPEN NC 55 TO THE PHASE 2, STEP 1 PATTERN.

UPON COMPLETION OF PHASE 1, STEPS 18 - 21, OPEN NEW SIDEWALKS COMPLETED DURING PHASE 1 CONSTRUCTION AND REMOVE OR COVER PEDESTRIAN SIGNING INSTALLED FOR PEDESTRIAN DETOURS.

PHASE 2 (SHEETS TMP-15 - TMP-18)

BEGIN PHASE 2, STEPS 1 - 2 CONCURRENTLY. BEGIN PHASE 2, STEPS 1 - 2 DIRECTLY FOLLOWING COMPLETION OF PHASE 1, STEPS 18 - 20.

STEP 1:

AWAY FROM TRAFFIC AND USING FLAGGERS, LANE CLOSURES (RSD 1101.02, SHEETS 1, 2, 3, AND 7 OF 15), AND LAW ENFORCEMENT AS NECESSARY, BEGIN INSTALLATION OF TEMPORARY SIGNALS 05-0228T7, 05-0284T5, 05-1026T4, 05-1027T6, 05-1028T3, AND 05-1029T7.

AWAY FROM TRAFFIC AND USING FLAGGERS AND LANE CLOSURES (RSD 1101.02, SHEETS 2 AND 3 OF 15) AS NECESSARY, BEGIN CONSTRUCTION OF THE FOLLOWING: (SEE SHEET TMP-15 - TMP-18)

- -LALT- FROM STA. 13+38 +/- TO STA. 20+00 +/- (RT), INCLUDING THE FOLLOWING:
 - > REMOVAL OF THE EAST SIDE OF THE EXISTING NC 55 BRIDGE OVER -YA- (NC 147) (SEE LOCAL NOTE LN-01)
 - > STAGE 2 OF THE NEW -LALT- BRIDGE OVER -YA- (SEE LOCAL NOTE LN-01)
 - > ASPHALT WEDGING FROM -LALT- STA. 13+38 +/- TO STA. 15+00 +/-
- -LALT- FROM STA. 21+00 +/- TO STA. 31+00 +/- (RT)
- -LALT- FROM STA. 32+00 +/- TO STA. 36+00 +/- (RT)
- -LALT- FROM STA. 37+20 +/- TO STA. 41+50 +/- (RT), INCLUDING TEMPORARY PAVEMENT FROM -LALT- STA. 38+66 +/- TO STA. 41+25 +/-, TEMPORARY PAVEMENT FROM -LALT- STA. 40+95 +/- TO STA. 41+25 +/-
- -LALT- FROM STA. 49+46 +/- TO STA. 53+70 +/- (LT)
- -LALT- FROM STA. 54+70 +/- TO STA. 56+70 +/- (LT)
- -LALT- FROM STA. 57+75 +/- TO STA. 63+30 +/- (LT)
- -LALT- FROM STA. 64+25 +/- TO STA. 66+10 +/- (LT)
- -R2-, INCLUDING ASPHALT WEDGING (USING DETOUR, AS SHOWN ON SHEET TMP-2G, AS NEEDED) (SEE LOCAL NOTE LN-01, SHEET TMP-2A)
- -R4-
- -NSN- FROM STA. 20+12 +/- TO STA. 21+95 +/- (BRIDGE)
- -Y- FROM STA. 17+05 +/- TO STA. 17+85 +/- (BRIDGE)
- -Y7-

USING RSD 1101.03, SHEET 1 OF 9, CLOSE AND DETOUR -Y16- (HOPKINS STREET), THEN AWAY FROM TRAFFIC AND USING FLAGGERS AND LANE CLOSURES (RSD 1101.01, SHEETS 1 AND 2 OF 15) AS NECESSARY, BEGIN CONSTRUCTION OF THE FOLLOWING: (SEE SHEET TMP-18 AND LOCAL NOTE LN-06) (SEE SHEET TMP-2S FOR DETOUR ROUTE.)

- -LALT- FROM STA. 53+70 +/- TO STA. 54+70 +/-
- -Y16- FROM STA. 10+35 +/- TO STA. 10+60 +/-
- TEMPORARY PAVEMENT FROM -LALT- STA. 53+70 +/- TO STA. 54+70 +/- TO PROVIDE A TEMPORARY CONNECTION ACROSS THE MEDIAN

THE CONTRACTOR SHALL COMPLETE THE WORK REQUIRED IN PHASE 2, STEP 2 IN THIRTY (30) CONSECUTIVE DAYS. (SEE INTERMEDIATE CONTRACT TIME AND LIQUIDATED DAMAGES)

STEP 2:

AWAY FROM TRAFFIC AND USING FLAGGERS, LANE CLOSURES (RSD 1101.02, SHEETS 1 AND 2 OF 15) AND LAW ENFORCEMENT AS NECESSARY, COMPLETE RECONSTRUCTION OF -Y5- (MAIN STREET), INCLUDING COMPLETION OF -LALT- FROM STA. 36+00 +/- TO STA. 37+20 +/- (SEE SHEET TMP-16)

WHEN REQUIRED, AWAY FROM TRAFFIC AND USING FLAGGERS, LANE CLOSURES (RSD 1101.02, SHEETS 1 AND 2 OF 15) AND LAW ENFORCEMENT AS NECESSARY, REMOVE TEMPORARY SHORING NO. 4, REMOVE PCB, AND COMPLETE NEW ROADWAY ADJACENT TO -LALT- ROADWAY COMPLETED IN PHASE 1.

UPON COMPLETION OF -Y5- RECONSTRUCTION AND ASSOCIATED -LALT- WORK, WORKING IN A CONTINUOUS MANNER AWAY FROM TRAFFIC AND USING FLAGGERS, LANE CLOSURES (RSD 1101.02, SHEETS 1 AND 2 OF 15), AND LAW ENFORCEMENT AS NECESSARY, COMPLETE THE FOLLOWING:

- INSTALL AND ACTIVATE TEMPORARY SIGNAL 05-1030T4
- PLACE TEMPORARY MARKINGS ON -Y5- (AS SHOWN ON SHEET TMP-20)
- REMOVE DETOUR AND REOPEN -Y5- TO THE TEMPORARY PATTERN

APPROVED  DATE: 5/13/2016

SEAL 



PHASING

DOCUMENT NOT CONSIDERED FINAL UNLESS ALL SIGNATURES COMPLETED

PLOT DRIVER: NCDOT_color_eng_50.plt
 USER: erbrooks
 FILE: c:\pwworking\tpa\d0487729\U-3308_TMP-03.dgn
 PENTABLE: NCDOT_tcp.tbl
 DATE: 5/12/2016
 TIME: 3:58:12 PM

REVISIONS

PROJ. REFERENCE NO.	SHEET NO.
U-3308	TMP-3D
 HDR Engineering, Inc. of the Carolinas 3733 National Drive, Suite 207 Raleigh, N.C. 27612 N.C.B.E.L.S. License Number: F-0116	

PHASING

PHASE 2 (CONTINUED)

THE CONTRACTOR MAY CONDUCT WORK IN PHASE 2, STEP 3 CONCURRENTLY WITH PHASE 2, STEPS 1, 2, AND/OR 4 - 11. PHASE 2, STEP 3 MAY NOT BE COMPLETED CONCURRENTLY WITH WORK AS NOTED IN LOCAL NOTE LN-01 (SEE SHEET TMP-2A).

THE CONTRACTOR SHALL COMPLETE THE WORK REQUIRED IN PHASE 2, STEP 3 IN FOURTEEN (14) CONSECUTIVE DAYS. (SEE INTERMEDIATE CONTRACT TIME AND LIQUIDATED DAMAGES)

STEP 3:

WORKING IN A CONTINUOUS MANNER, AWAY FROM TRAFFIC AND USING FLAGGERS, LANE CLOSURES (RSD 1101.02, SHEETS 1 AND 2 OF 15), AND LAW ENFORCEMENT AS NECESSARY, COMPLETE INSTALLATION OF AND ACTIVATE TEMPORARY SIGNAL 05-0284T5, THEN CLOSE AND DETOUR -R5-. (SEE SHEET TMP-2H FOR DETOUR ROUTE)

UPON CLOSURE OF -R5-, AWAY FROM TRAFFIC AND USING FLAGGERS AND LANE CLOSURES (RSD 1101.02, SHEETS 1 AND 2 OF 15) AS NECESSARY, COMPLETE RECONSTRUCTION OF -R5-, INCLUDING COMPLETION OF -LALT- FROM STA. 20+00 +/- TO STA. 21+00 +/- (RT). (SEE SHEET TMP-15)

UPON COMPLETION OF -R5- AND ASSOCIATED -LALT- WORK, WORKING IN A CONTINUOUS MANNER AWAY FROM TRAFFIC AND USING FLAGGERS, LANE CLOSURES (RSD 1101.02, SHEETS 1 AND 2 OF 15), AND LAW ENFORCEMENT AS NECESSARY, INSTALL AND ACTIVATE TEMPORARY SIGNAL 05-0284T6, PLACE TEMPORARY MARKINGS ON -R5- (AS SHOWN ON SHEET TMP-19), THEN REMOVE THE DETOUR AND REOPEN -R5- TO THE TEMPORARY PATTERN.

THE CONTRACTOR MAY CONDUCT WORK IN PHASE 2, STEP 4 CONCURRENTLY WITH PHASE 2, STEPS 1 - 3, 5, 6, 8, AND/OR 10 - 11. PHASE 2, STEP 4 MAY NOT BE COMPLETED CONCURRENTLY WITH PHASE 2, STEPS 7 OR 9.

THE CONTRACTOR SHALL COMPLETE THE WORK REQUIRED IN PHASE 2, STEP 4 IN FOURTEEN (14) CONSECUTIVE DAYS. (SEE INTERMEDIATE CONTRACT TIME AND LIQUIDATED DAMAGES)

STEP 4:

WORKING IN A CONTINUOUS MANNER, AWAY FROM TRAFFIC AND USING FLAGGERS, LANE CLOSURES (RSD 1101.02, SHEETS 1 AND 2 OF 15), AND LAW ENFORCEMENT AS NECESSARY, COMPLETE INSTALLATION OF AND ACTIVATE TEMPORARY SIGNAL 05-1029T7, THEN CLOSE AND DETOUR -Y18- (LIBERTY STREET). (SEE SHEET TMP-2S FOR DETOUR ROUTE)

USING RSD 1101.03, SHEET 1 OF 9, UPON CLOSURE OF -Y18-, AWAY FROM TRAFFIC AND USING FLAGGERS AND LANE CLOSURES (RSD 1101.02, SHEETS 1 AND 2 OF 15) AS NECESSARY, COMPLETE RECONSTRUCTION OF -Y18-, INCLUDING COMPLETION OF -LALT- FROM STA. 56+70 +/- TO STA. 57+75 +/- (LT). (SEE SHEET TMP-18)

UPON COMPLETION OF -Y18- AND ASSOCIATED -LALT- WORK, WORKING IN A CONTINUOUS MANNER AWAY FROM TRAFFIC AND USING FLAGGERS, LANE CLOSURES (RSD 1101.02, SHEETS 1 AND 2 OF 15), AND LAW ENFORCEMENT AS NECESSARY, INSTALL AND ACTIVATE TEMPORARY SIGNAL 05-1029T8, PLACE TEMPORARY MARKINGS ON -Y18- (AS SHOWN ON SHEET TMP-22), THEN REMOVE THE DETOUR AND REOPEN -Y18- TO THE TEMPORARY PATTERN.

STEP 5:

AWAY FROM TRAFFIC AND USING FLAGGERS, LANE CLOSURES (RSD 1101.02, SHEETS 1 AND 2 OF 15), AND LAW ENFORCEMENT AS NECESSARY, BEGIN INSTALLATION OF TEMPORARY SIGNAL 05-1030T5.

COMPLETE CONSTRUCTION OF -LALT- FROM STA. 37+20 +/- TO STA. 41+50 +/- AND -Y7- BEGUN EARLIER.

COMPLETE CONSTRUCTION OF -LALT- FROM STA. 53+70 +/- TO STA. 54+70 +/- AND -Y16- BEGUN EARLIER.

COMPLETE CONSTRUCTION OF -Y- AND -Y3A- BEGUN EARLIER.

STEP 6:

AWAY FROM TRAFFIC AND USING FLAGGERS AND LANE CLOSURES (RSD 1101.02, SHEET 1 OF 15) AS NECESSARY, INSTALL TEMPORARY PAVEMENT MARKINGS IN THE FINAL PATTERN ON -Y- AND -Y3A-, THEN OPEN -Y- AND -Y3A- TO THE FINAL PATTERN, AS SHOWN ON SHEET TMP-19.

WORKING IN A CONTINUOUS MANNER, AWAY FROM TRAFFIC AND USING FLAGGERS, LANE CLOSURES (RSD 1101.02, SHEETS 1 AND 2 OF 15), AND LAW ENFORCEMENT AS NECESSARY, COMPLETE INSTALLATION OF AND ACTIVATE TEMPORARY SIGNAL 05-1030T5, INSTALL TEMPORARY PAVEMENT MARKINGS ON -LALT- FROM STA. 36+00 +/- TO STA. 47+68 +/-, -Y7-, AND -Y16- (AS SHOWN ON SHEETS TMP-20 - TMP-22), REOPEN -Y7- AND -Y16-, THEN SHIFT TRAFFIC TO THE TEMPORARY PATTERN ON -LALT-.

PHASE 2 (SHEETS TMP-19 - TMP-24)

STEP 7:

AWAY FROM TRAFFIC AND USING FLAGGERS, LANE CLOSURES (RSD 1101.02, SHEETS 1, 2, 3, AND 7 OF 15), AND LAW ENFORCEMENT AS NECESSARY, BEGIN INSTALLATION OF TEMPORARY SIGNALS 05-0284T7 AND 05-1028T3.

AWAY FROM TRAFFIC AND USING FLAGGERS, LANE CLOSURES (RSD 1101.02, SHEETS 1 AND 2 OF 15), AND LAW ENFORCEMENT AS NECESSARY, BEGIN INSTALLATION OF FINAL SIGNALS 05-1029 AND 05-1030.

WORKING IN A CONTINUOUS MANNER, AWAY FROM TRAFFIC AND USING FLAGGERS, LANE CLOSURES (RSD 1101.02, SHEETS 1 AND 2 OF 15), AND LAW ENFORCEMENT AS NECESSARY, COMPLETE INSTALLATION OF AND ACTIVATE TEMPORARY SIGNAL 05-1026T4, THEN USING RSD 1101.03, SHEET 1 OF 9, CLOSE AND DETOUR -Y2- (ANGIER AVENUE). (SEE SHEET TMP-2L FOR DETOUR ROUTE.) UPON CLOSURE OF -Y2-, USING FLAGGERS AND LANE CLOSURES (RSD 1101.01, SHEET 1 OF 15) AS NECESSARY, BEGIN CONSTRUCTION OF THE FOLLOWING: (SEE SHEETS TMP-20 - TMP-21 AND LOCAL NOTE LN-05)

- -LALT- FROM STA. 31+00 +/- TO STA. 32+00 +/-
- -Y2-

USING RSD 1101.03, SHEET 1 OF 9, CLOSE AND DETOUR -Y6- (MORNING GLORY AVENUE), THEN AWAY FROM TRAFFIC AND USING FLAGGERS AND LANE CLOSURES (RSD 1101.01, SHEET 1 OF 15) AS NECESSARY, BEGIN CONSTRUCTION OF THE FOLLOWING: (SEE SHEETS TMP-20 - TMP-21 AND LOCAL NOTE LN-05) (SEE SHEET TMP-20 FOR DETOUR ROUTE.)

- -LALT- FROM STA. 39+00 +/- TO STA. 41+25 +/-
- -Y6-
- TEMPORARY PAVEMENT FROM -LALT- STA. 40+20 +/- TO STA. 41+25 +/- TO PROVIDE A TEMPORARY CONNECTION ACROSS THE MEDIAN

USING RSD 1101.03, SHEET 1 OF 9, CLOSE AND DETOUR -Y14- (TAYLOR STREET), THEN AWAY FROM TRAFFIC AND USING FLAGGERS AND LANE CLOSURES (RSD 1101.01, SHEET 1 OF 15) AS NECESSARY, COMPLETE INSTALLATION OF AND ACTIVATE TEMPORARY SIGNAL 05-0228T7, THEN BEGIN CONSTRUCTION OF THE FOLLOWING: (SEE SHEET TMP-21) (SEE SHEET TMP-2S FOR DETOUR ROUTE)

- -LALT- FROM STA. 48+30 +/- TO STA. 49+46 +/-
- -Y14-

AWAY FROM TRAFFIC AND USING FLAGGERS AND LANE CLOSURES (RSD 1101.01, SHEETS 1 AND 2 OF 15) AS NECESSARY, BEGIN CONSTRUCTION OF THE FOLLOWING: (SEE SHEET TMP-21)

- -LALT- FROM STA. 41+25 +/- TO STA. 42+50 +/- (LT)
- -LALT- FROM STA. 47+25 +/- TO STA. 48+30 +/- (LT)

STEP 8:

COMPLETE CONSTRUCTION OF -LALT- FROM STA. 39+00 +/- TO STA. 41+25 +/- AND -Y6- BEGUN EARLIER. UPON COMPLETION, WORKING IN A CONTINUOUS MANNER AWAY FROM TRAFFIC AND USING FLAGGERS, LANE CLOSURES (RSD 1101.02, SHEETS 1 AND 2 OF 15), AND LAW ENFORCEMENT AS NECESSARY, PLACE TEMPORARY MARKINGS (AS SHOWN ON SHEET TMP-23), THEN REMOVE THE DETOUR AND REOPEN -Y6- TO THE TEMPORARY PATTERN.

COMPLETE CONSTRUCTION OF -LALT- FROM STA. 48+30 +/- TO STA. 49+46 +/- AND -Y14- BEGUN EARLIER. UPON COMPLETION, WORKING IN A CONTINUOUS MANNER AWAY FROM TRAFFIC AND USING FLAGGERS, LANE CLOSURES (RSD 1101.02, SHEETS 1 AND 2 OF 15), AND LAW ENFORCEMENT AS NECESSARY, INSTALL AND ACTIVATE TEMPORARY SIGNAL 05-0228T8, PLACE TEMPORARY MARKINGS ON -Y14- (AS SHOWN ON SHEET TMP-23), THEN REMOVE THE DETOUR AND REOPEN -Y14- TO THE TEMPORARY PATTERN.



DURING A NIGHT OPERATION FROM 8:00 PM UNTIL 6:00 AM THE FOLLOWING MORNING, AND USING FLAGGERS, LANE CLOSURES (RSD 1101.02, SHEETS 1 AND 3 OF 15) AND LAW ENFORCEMENT AS NECESSARY, COMPLETE CLOSURE POUR ON THE NC 55 BRIDGE OVER NC 147, AS SHOWN ON SHEET TMP-19. (REPEAT NIGHT OPERATION AS NECESSARY UNTIL COMPLETION OF THE CLOSURE POUR.)

NOTE - A NIGHT, ONE-LANE OPERATION SHALL BE USED IN ORDER TO MINIMIZE VIBRATIONS ON THE BRIDGE DURING PLACEMENT OF THE CONCRETE CLOSURE POUR.

REVISIONS

PLOT DRIVER: NCDOT_pdf_color_eng_50.plt
 USER: erbrooks
 FILE: c:\pwworking\pa\d0487729\U-3308_TMP-TMP-03.dgn
 PENTABLE: NCDOT_tcp.tbl
 DATE: 5/12/2016
 TIME: 3:58:13 PM

DOCUMENT NOT CONSIDERED FINAL
 UNLESS ALL SIGNATURES COMPLETED

APPROVED  DATE: 5/13/2016 SEAL 		PHASING
--	---	---------

PHASING

PROJ. REFERENCE NO. SHEET NO.

U-3308 TMP-3E

HDR HDR Engineering, Inc. of the Carolinas
3733 National Drive, Suite 207 Raleigh, N.C. 27612
N.C.B.E.L.S. License Number: F-0116

PHASE 2 (CONTINUED)

THE CONTRACTOR MAY CONDUCT WORK IN PHASE 2, STEP 9 UPON COMPLETION OF PHASE 2, STEP 8. PHASE 2, STEP 9 MAY NOT BE COMPLETED DURING CLOSURES OF -Y14-, -Y16-, OR -Y18-.

THE CONTRACTOR SHALL COMPLETE THE WORK REQUIRED IN PHASE 2, STEP 9 IN FOURTEEN (14) CONSECUTIVE DAYS. (SEE INTERMEDIATE CONTRACT TIME AND LIQUIDATED DAMAGES)

STEP 9:

INSTALL PEDESTRIAN DETOUR SIGNING FOR CLOSURE OF THE SIDEWALK ON HOLLOWAY STREET FROM NC 55 TO EVA STREET. (SEE SHEET TMP-2AA FOR PEDESTRIAN DETOUR ROUTE)

WORKING IN A CONTINUOUS MANNER, AWAY FROM TRAFFIC AND USING FLAGGERS, LANE CLOSURES (RSD 1101.02, SHEETS 1 AND 2 OF 15), AND LAW ENFORCEMENT AS NECESSARY, COMPLETE INSTALLATION OF AND ACTIVATE TEMPORARY SIGNAL 05-1027T6, THEN USING RSD 1101.03, SHEET 1 OF 9, CLOSE AND DETOUR -Y22- (HOLLOWAY STREET). (SEE SHEET TMP-2U FOR DETOUR ROUTE)

UPON CLOSURE OF -Y22-, AWAY FROM TRAFFIC AND USING FLAGGERS AND LANE CLOSURES (RSD 1101.02, SHEETS 1 AND 2 OF 15) AS NECESSARY, COMPLETE RECONSTRUCTION OF -Y22-, INCLUDING COMPLETION OF -LALT- FROM STA. 63+30 +/- TO STA. 64+25 +/- (RT). (SEE SHEET TMP-22)

UPON COMPLETION OF -Y22- AND ASSOCIATED -LALT- WORK, WORKING IN A CONTINUOUS MANNER AWAY FROM TRAFFIC AND USING FLAGGERS, LANE CLOSURES (RSD 1101.02, SHEETS 1 AND 2 OF 15), AND LAW ENFORCEMENT AS NECESSARY, INSTALL AND ACTIVATE TEMPORARY SIGNAL 05-1027T7, PLACE TEMPORARY MARKINGS ON -Y22- (AS SHOWN ON SHEET TMP-24), THEN REMOVE THE DETOUR AND REOPEN -Y22- TO THE TEMPORARY PATTERN.

ADJUST AND REVISE PEDESTRIAN DETOUR SIGNING ON -Y22- (HOLLOWAY STREET) (FROM ELIZABETH STREET TO ALSTON AVENUE) TO MAINTAIN CLOSURE OF THE CROSSWALK ON THE SOUTH LEG OF THE ALSTON AVENUE / HOLLOWAY STREET INTERSECTION, AS SHOWN ON SHEET TMP-24. MAINTAIN CLOSURE OF THIS CROSSWALK UNTIL COMPLETION OF THE NC 55 NB RIGHT-TURN CHANNELIZATION ISLAND IN PHASE 3, STEP 1.

STEP 10:

AWAY FROM TRAFFIC AND USING FLAGGERS, LANE CLOSURES (RSD 1101.02, SHEETS 1 AND 2 OF 15), AND LAW ENFORCEMENT AS NECESSARY, BEGIN INSTALLATION OF FINAL SIGNALS 05-0228, 05-1026, AND 05-1027.

CLOSE -Y8- (WORTH STREET), -Y10- (FRANKLIN STREET), AND -Y12- (WALL STREET) TO THROUGH TRAFFIC, THEN USING FLAGGERS AND LANE CLOSURES (RSD 1101.01, SHEET 1 OF 15) AS NECESSARY, COMPLETE CONSTRUCTION OF THE FOLLOWING: (SEE SHEET TMP-23)

- -LALT- FROM STA. 42+50 +/- TO STA. 47+25 +/-
- -Y8-
- -Y10-
- -Y12-

NOTE - MAINTAIN CLOSURE OF THROUGH TRAFFIC ON -Y8-, -Y10-, AND -Y12- UNTIL TRAFFIC IS SHIFTED TO THE FINAL PATTERN IN PHASE 3.

COMPLETE ALL WORK BEGUN EARLIER IN THE FOLLOWING LOCATIONS:

- -LALT- FROM STA. 13+50 +/- TO STA. 35+82 +/- (RT)
- -LALT- FROM STA. 41+25 +/- TO STA. 42+50 +/- (LT)
- -LALT- FROM STA. 47+25 +/- TO STA. 66+10 +/- (LT)
- -R2-
- -R4-
- -Y2-
- -NSN- / -NSS- RAIL LINES

STEP 11:

SHIFT ALL RAIL TRAFFIC TO -NSN- / -NSS- TRACKS, THEN COMPLETE THE FOLLOWING: (SEE SHEET TMP-19)

- REMOVE RAIL DETOUR TRACKS
- REMOVE TEMPORARY SPAN ON -CSX- BRIDGE OVER -LALT-
- COMPLETE FINAL SPAN ON -CSX- BRIDGE OVER -LALT- (SEE LOCAL NOTE LN-02, SHEET TMP-2A)

UPON COMPLETION OF -CSX- BRIDGE, OPEN ALL TRACKS TO RAIL TRAFFIC.

WORKING IN A CONTINUOUS MANNER, AWAY FROM TRAFFIC AND USING FLAGGERS AND LANE CLOSURES (RSD 1101.02, SHEETS 1 AND 2 OF 15) AND LAW ENFORCEMENT AS NECESSARY, COMPLETE THE FOLLOWING IN THIS ORDER:

1. COMPLETE INSTALLATION OF AND ACTIVATE FINAL SIGNALS 05-0228, 05-0284, 05-1026, 05-1027, 05-1028, 05-1029, AND 05-1030
2. PLACE TEMPORARY PAVEMENT MARKINGS IN THE FINAL PATTERN ON -LALT- WHERE NOTED AND ON ALL -Y- LINES, AS SHOWN ON SHEETS TMP-25 - TMP-28. PLACE TEMPORARY MARKINGS IN A TEMPORARY PATTERN ON -LALT- WHERE SHOWN.
3. REOPEN -R4- AND -Y2-, THEN SHIFT TRAFFIC TO THE PHASE 3, STEP 1 PATTERN.

PHASE 3

STEP 1:

USING LANE CLOSURES (RSD 1101.02, SHEET 3 OF 15) AS NECESSARY, COMPLETE ALL MEDIAN ISLANDS (CONCRETE AND LANDSCAPED) ON -LALT- FROM STA. 17+66 +/- TO STA. 63+17 +/- . (SEE SHEETS TMP-25 - TMP-28)

STEP 2:

INSTALL PEDESTRIAN DETOUR SIGNING FOR CLOSURE OF THE SIDEWALK ON NC 55 FROM HOLLOWAY STREET TO GILBERT STREET. (SEE SHEET TMP-2AB FOR PEDESTRIAN DETOUR ROUTE)

USING LANE CLOSURES (RSD 1101.02, SHEET 4 OF 15), REMOVE TEMPORARY GUARDRAIL ALONG -YA- (NC 147) UNDER THE NEW -LALT- (NC 55) BRIDGE, AND INSTALL PERMANENT GUARDRAIL (AS SHOWN ON SHEET TMP-25).

USING LANE CLOSURES (RSD 1101.02, SHEET 3 OF 15) AS NECESSARY, COMPLETE ALL REMAINING CONSTRUCTION ON THE -LALT- BRIDGE OVER -YA- (NC 147).

USING LANE CLOSURES (RSD 1101.02, SHEET 3 OF 15) AS NECESSARY, COMPLETE ALL REMAINING CONSTRUCTION IN THE FOLLOWING LOCATIONS: (SEE SHEETS TMP-25, TMP-27, AND TMP-28)

- -LALT- FROM STA. 14+58 +/- TO STA. 15+35 +/- (LT)
- -LALT- FROM STA. 17+62 +/- TO STA. 18+41 +/- (LT), INCLUDING REMAINING WORK ON -R3-
- -LALT- / -Y7- INTERSECTION (NE QUADRANT)
- -LALT- / -Y15- INTERSECTION (NE QUADRANT)
- -LALT- / -Y17- INTERSECTION (NE QUADRANT)
- -LALT- / -Y18- INTERSECTION (NE QUADRANT)
- -LALT- / -Y22- INTERSECTION (NE QUADRANT)

STEP 3:

USING FLAGGERS, LANE CLOSURES (RSD 1101.02, ALL SHEETS), AND LAW ENFORCEMENT AS NECESSARY, PLACE FINAL LAYER OF ASPHALT SURFACE COURSE ON ALL ROADS.

USING FLAGGERS, LANE CLOSURES (RSD 1101.02, ALL SHEETS), AND LAW ENFORCEMENT AS NECESSARY, PLACE ALL FINAL PAVEMENT MARKINGS AND MARKERS, THEN OPEN ALL LANES TO THE FINAL PATTERN.

REMOVE ALL REMAINING TRAFFIC CONTROL DEVICES.

REVISIONS

PLOT DRIVER: NCDOT_pdf_color_eng_50.plt
PENTABLE: NCDOT_tcp.tbl
USER: erbrooks
DATE: 5/12/2016
TIME: 3:58:14 PM
FILE: c:\pwworking\paw\0487729-U-3308-TMP-TMP-03.dgn

DOCUMENT NOT CONSIDERED FINAL
UNLESS ALL SIGNATURES COMPLETED

APPROVED *R. Erskine Brooks* DATE: 5/13/2016

SEAL

DIVISION OF HIGHWAYS
STATE OF NORTH CAROLINA
DEPARTMENT OF TRANSPORTATION
WORK ZONE TRAFFIC CONTROL

PHASING

NC 55 BRIDGE OVER NC 147

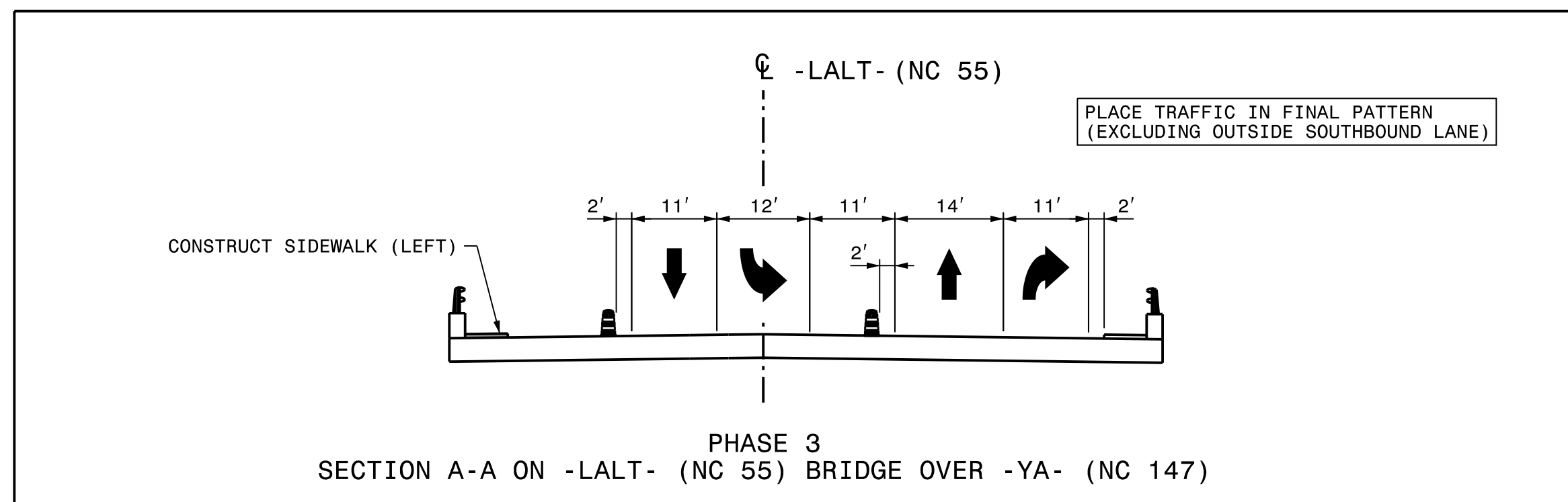
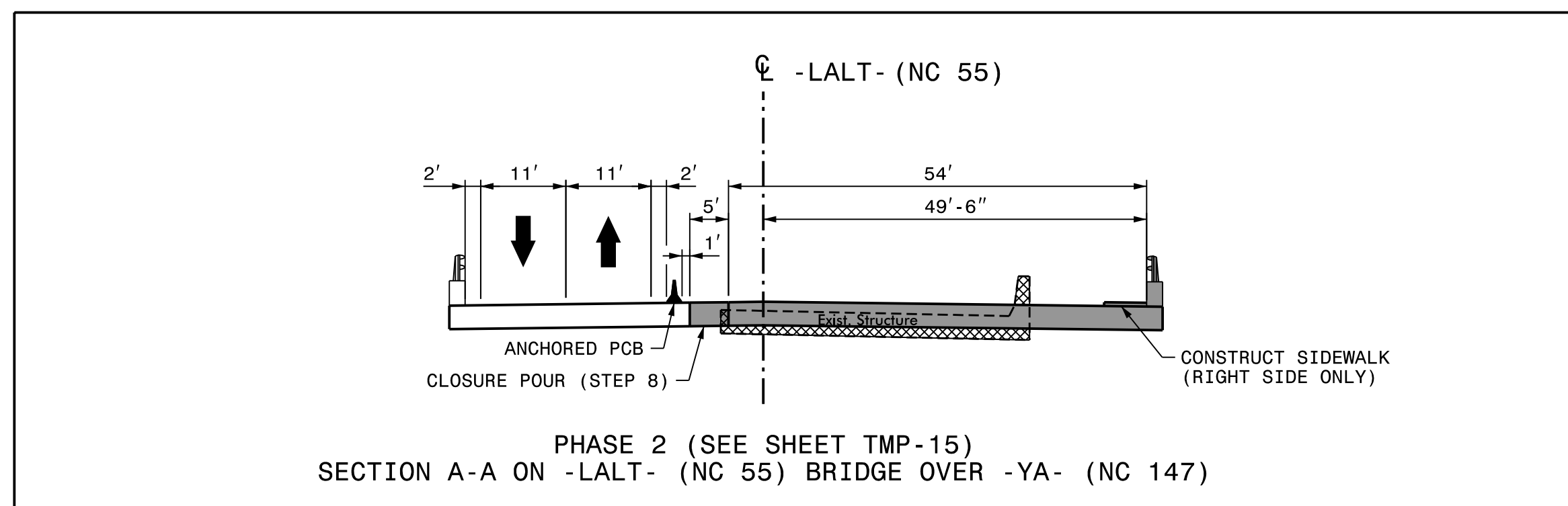
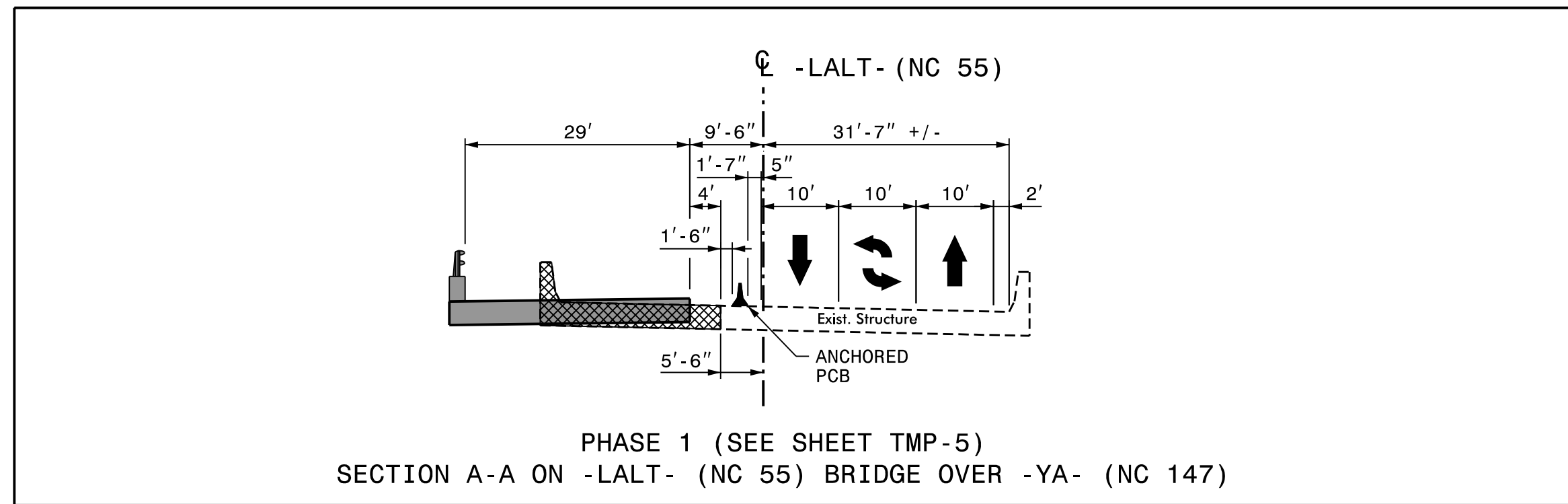

NC 55 BRIDGE OVER NC 147

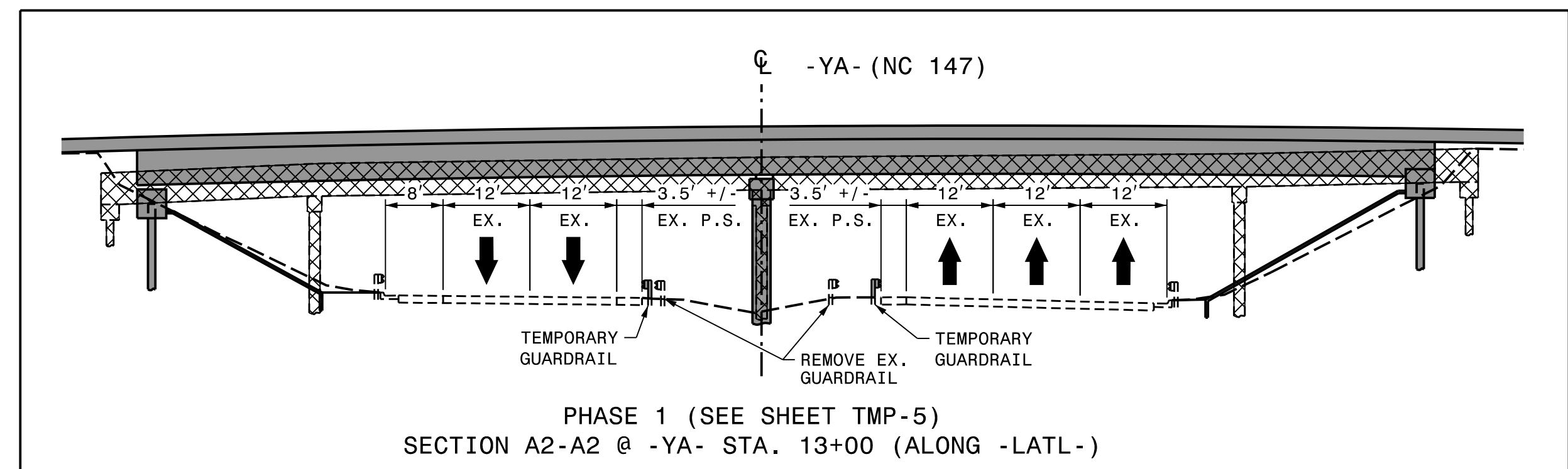
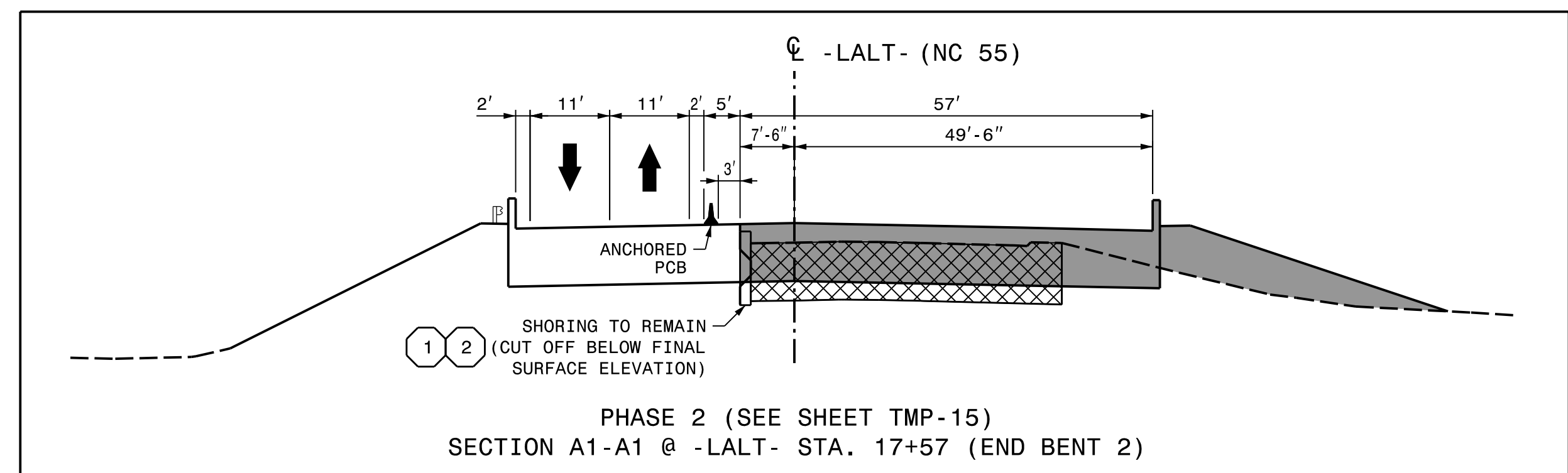
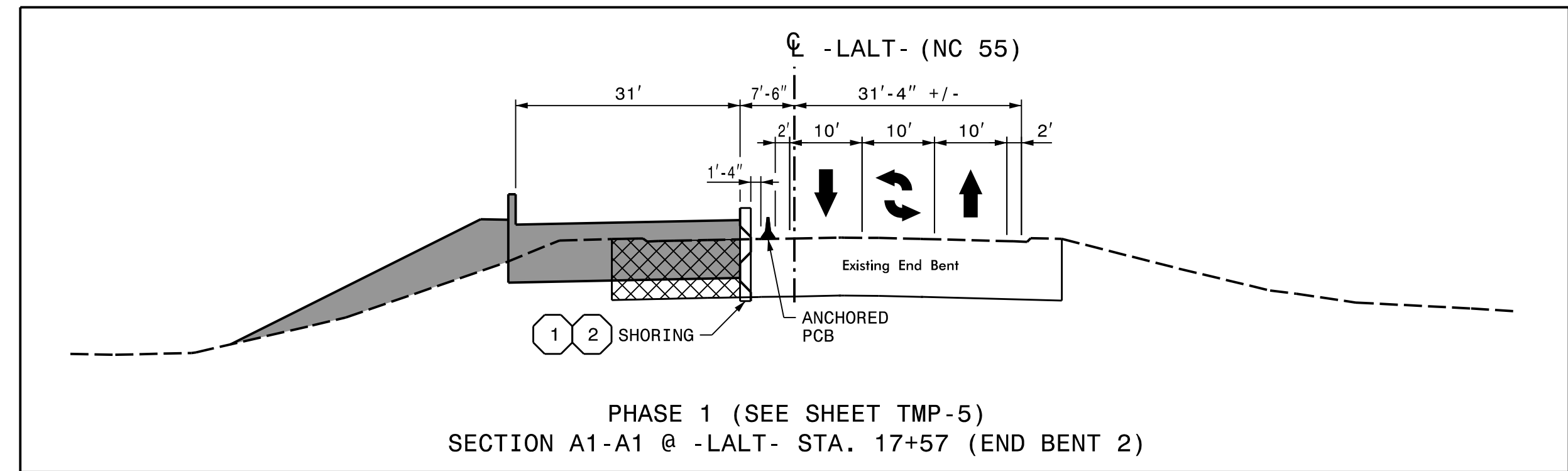

REVISIONS

PLOT DRIVER: NCDOT_pdf_color_eng_50.plt
 USER: erbrooks
 DATE: 5/12/2016
 TIME: 3:58:25 PM
 FILE: c:\pwworking\tpa\d0487729\U-3308_TMP-04.dgn

DOCUMENT NOT CONSIDERED FINAL
UNLESS ALL SIGNATURES COMPLETED

APPROVED  DATE: 5/13/2016

SEAL



-LALT- & -Y- BRIDGE
STAGING TYPICALS

PETTIGREW STREET BRIDGE OVER NC 55

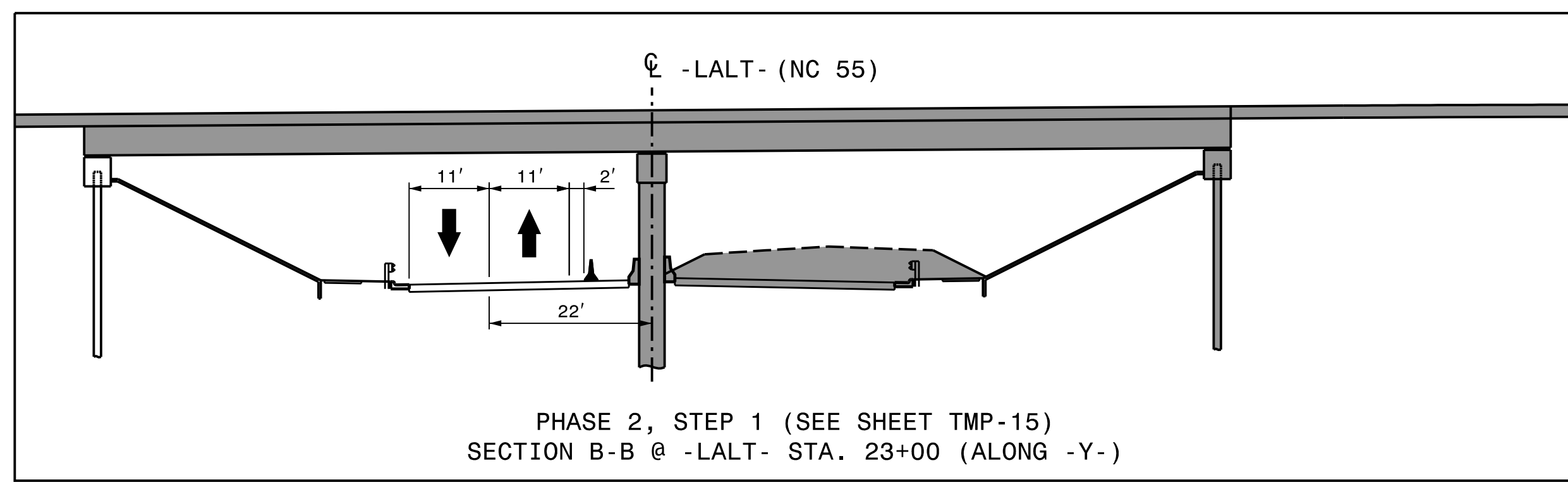
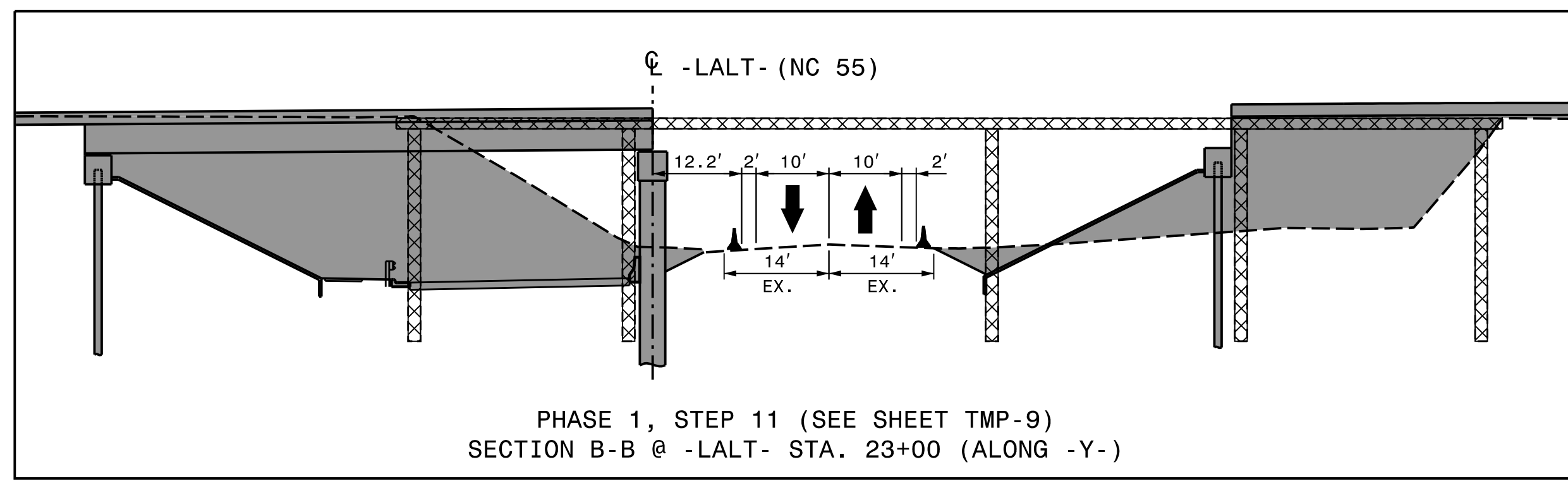

CSX BRIDGE OVER NC 55

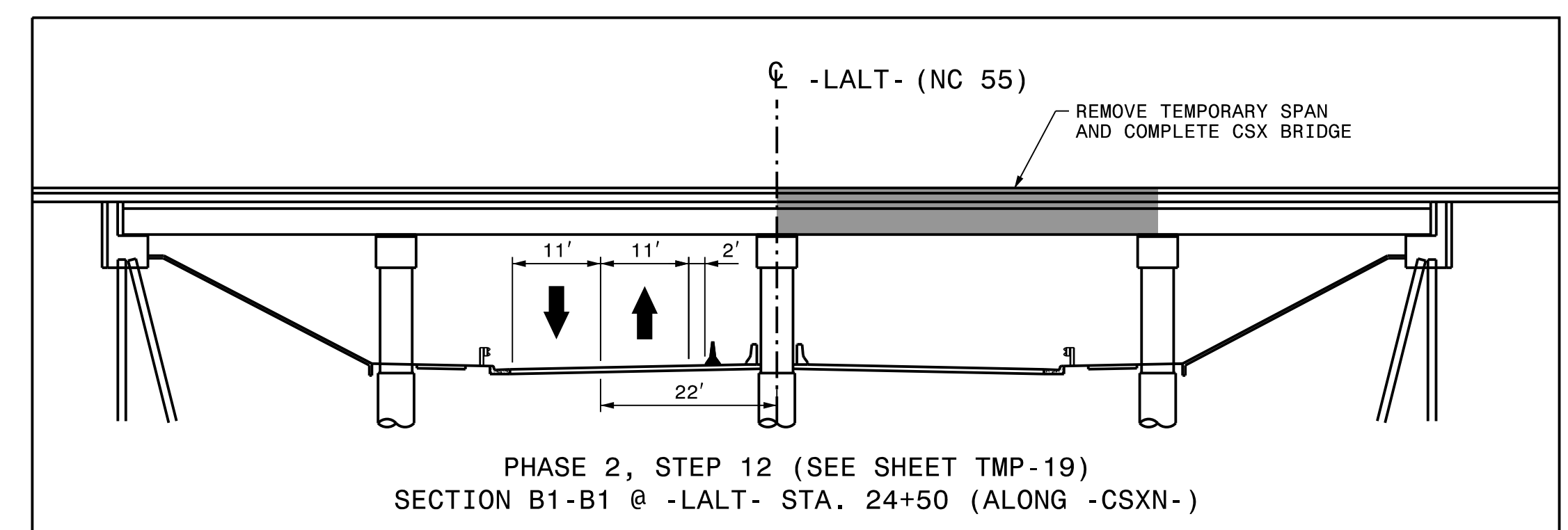
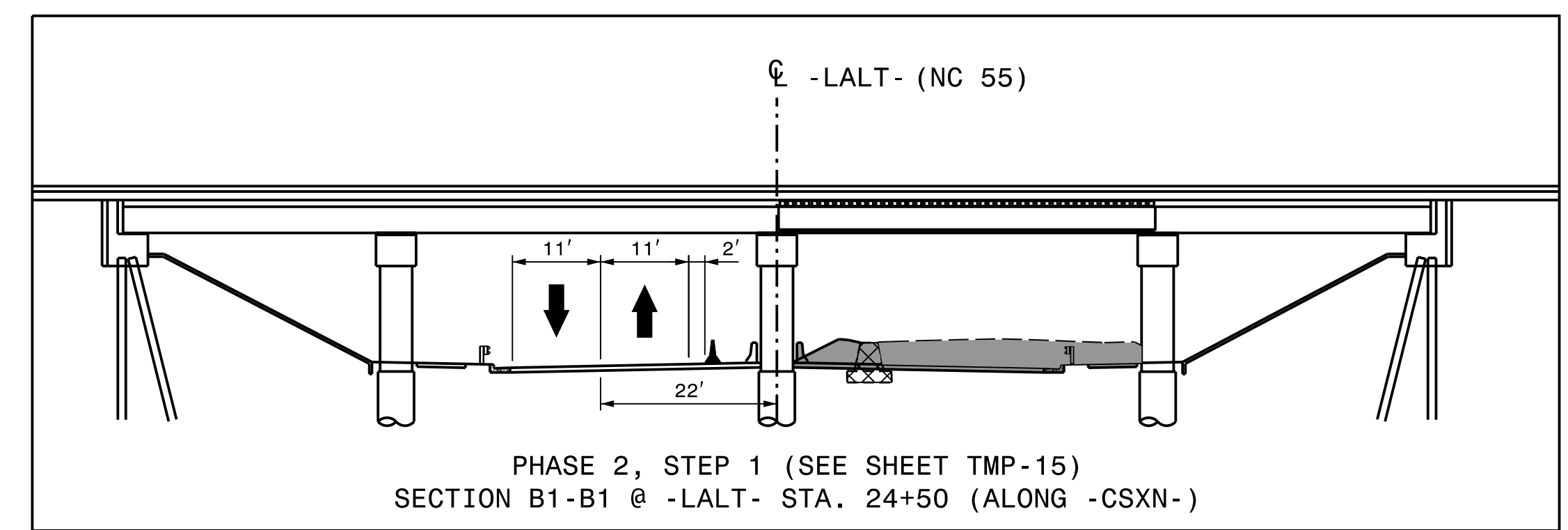
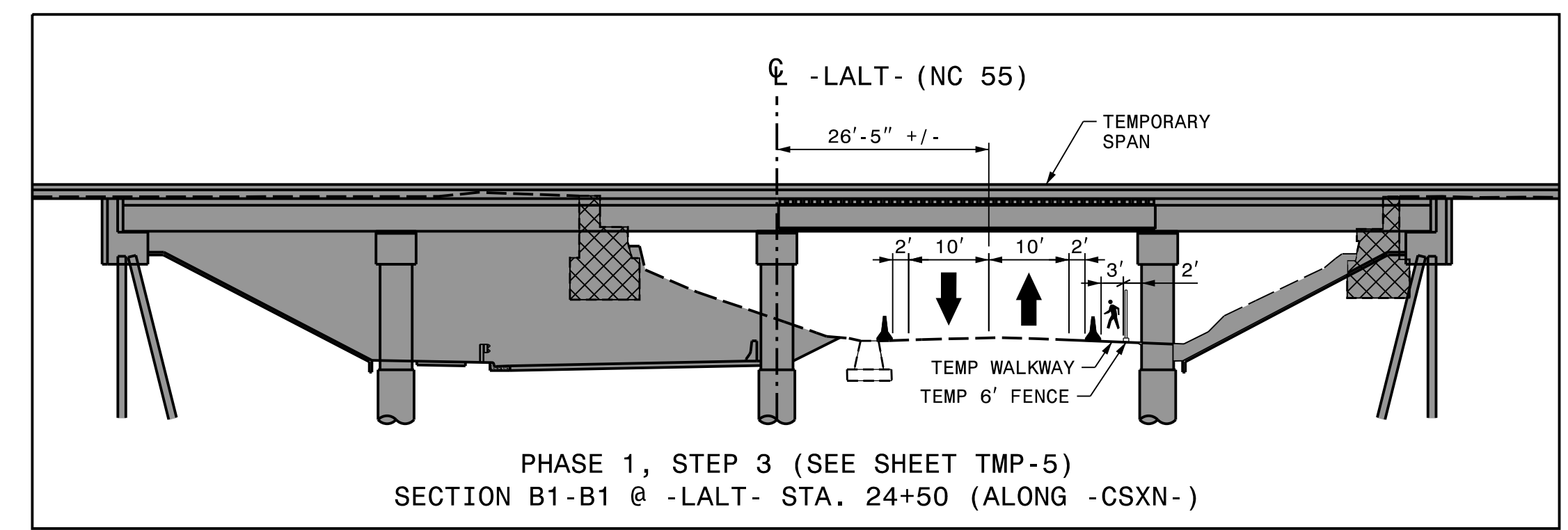
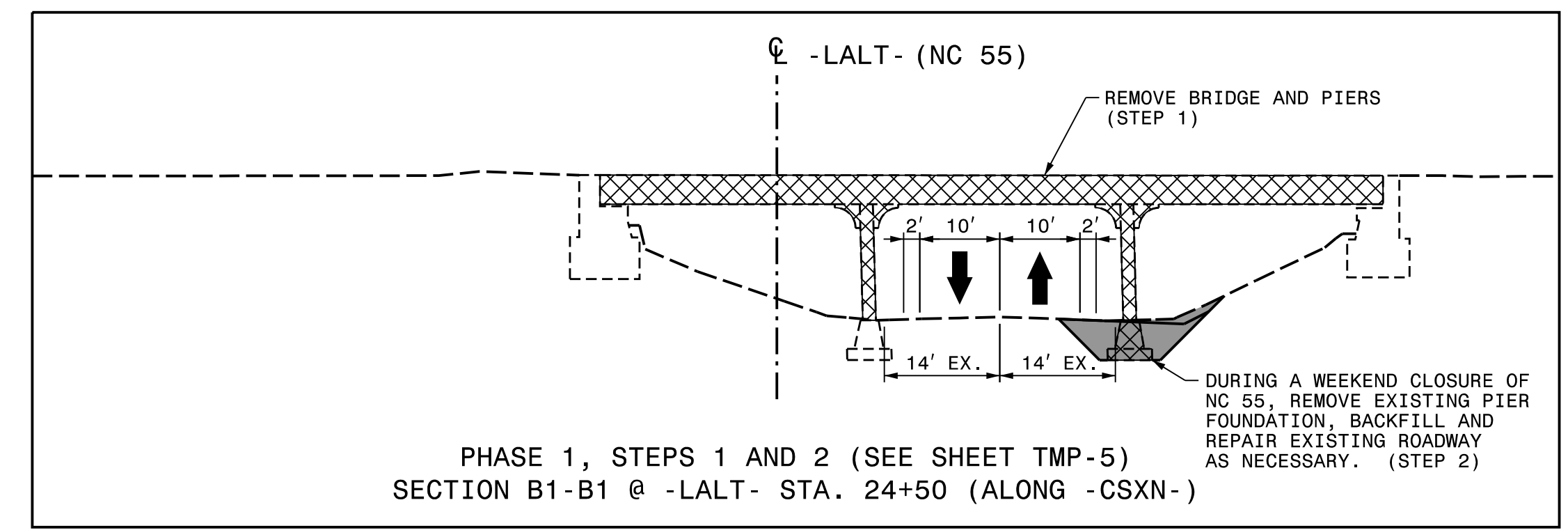

REVISIONS

PLOT DRIVER: NCDOT_pdf_color_eng_50.pit
 USER: erbrooks
 FILE: c:\pwworking\tpa\d0487729\U-3308_TMP-TMP-04A.dgn

PENTABLE: NCDOT_tcp.tbl
 DATE: 5/12/2016
 TIME: 3:58:36 PM

DOCUMENT NOT CONSIDERED FINAL UNLESS ALL SIGNATURES COMPLETED

APPROVED  DATE: 5/13/2016

SEAL

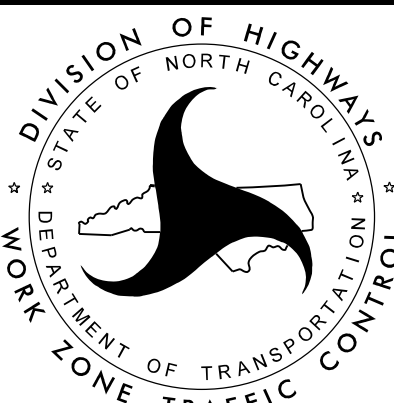
DIVISION OF HIGHWAYS
 STATE OF NORTH CAROLINA
 DEPARTMENT OF TRANSPORTATION
 WORK ZONE TRAFFIC CONTROL

-LALT- & -Y- BRIDGE STAGING TYPICALS

NSRR & CSX BRIDGES OVER NC 55



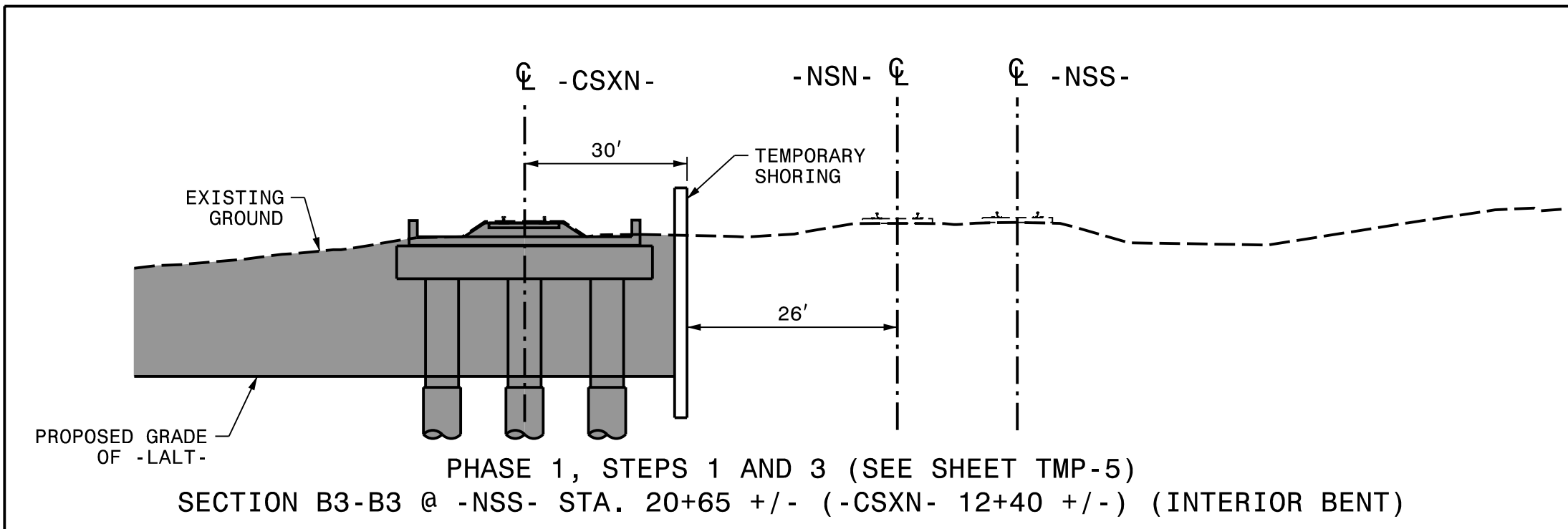
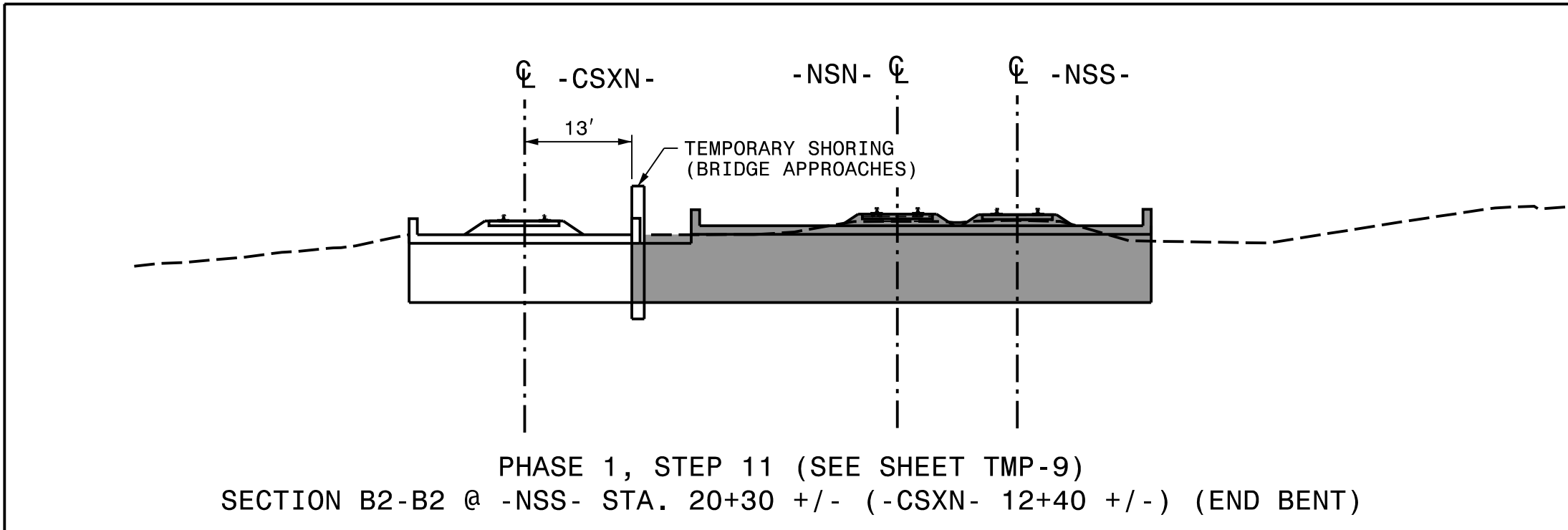
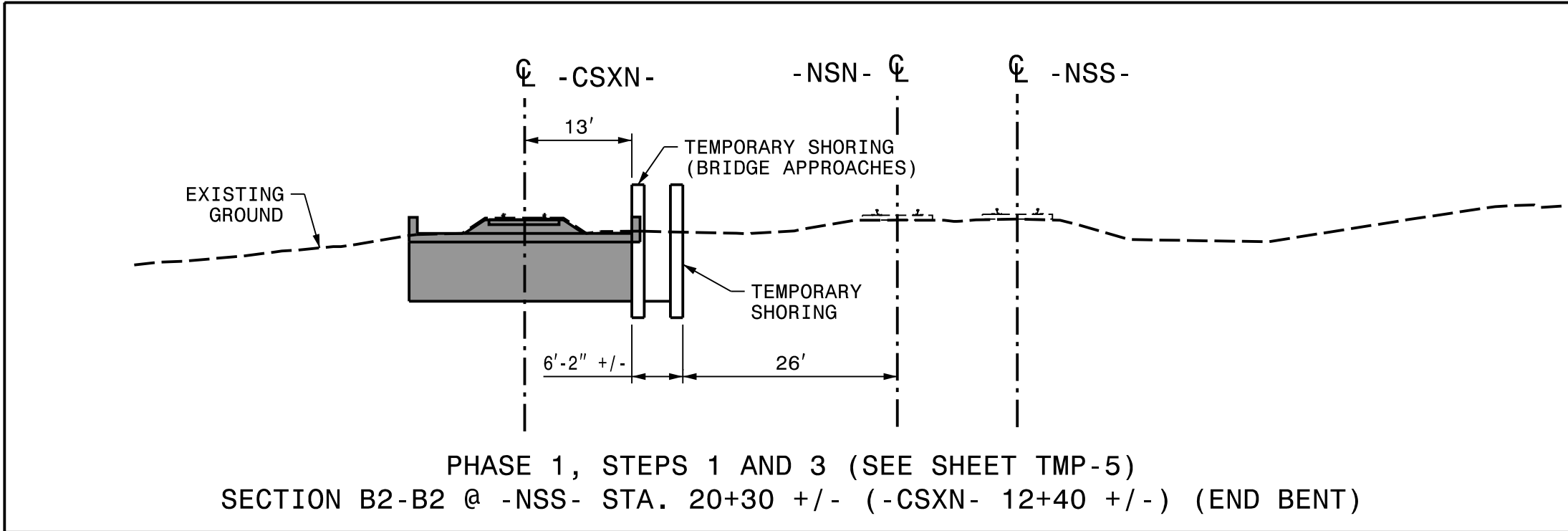

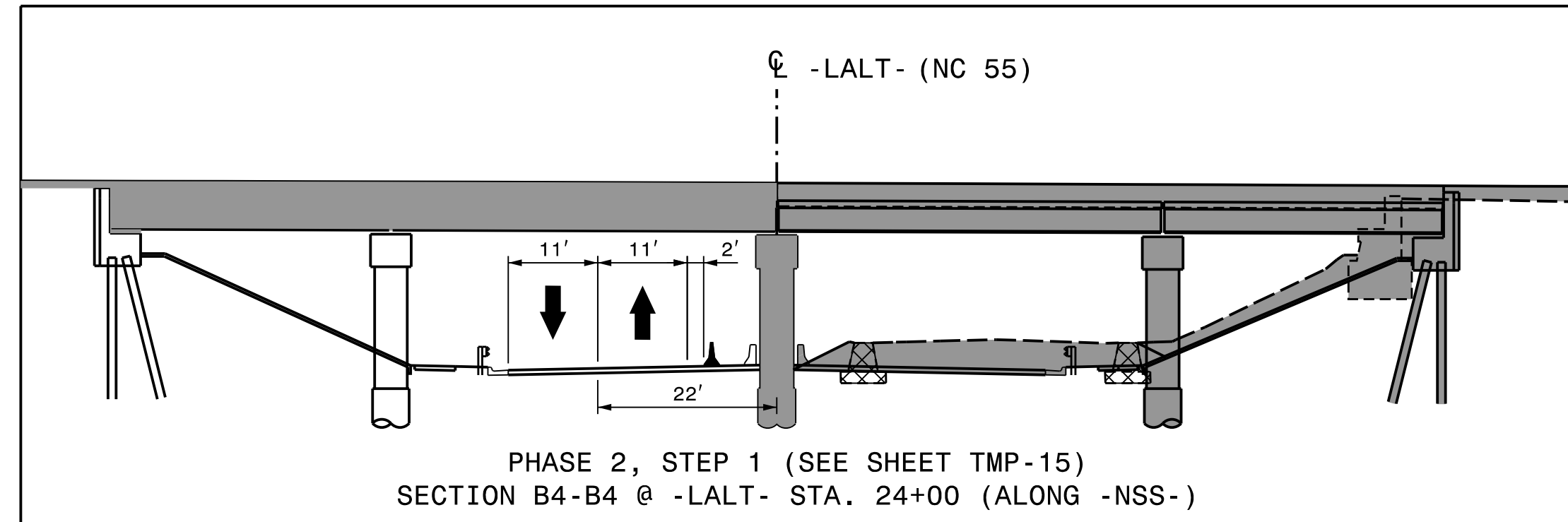
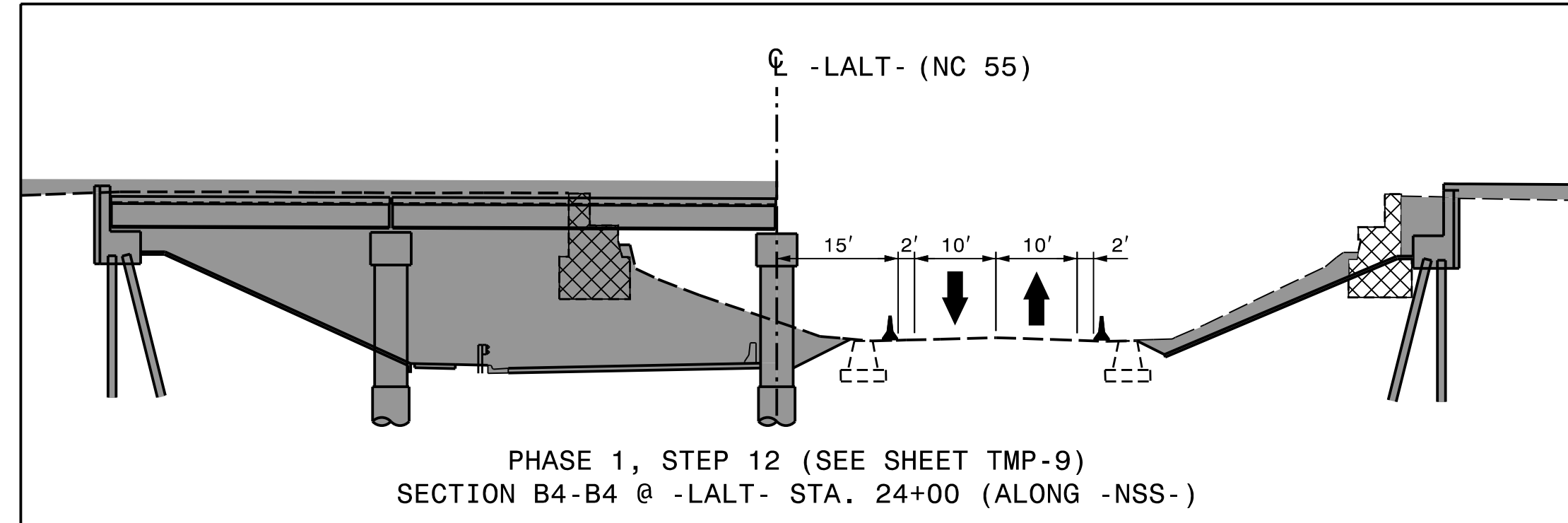
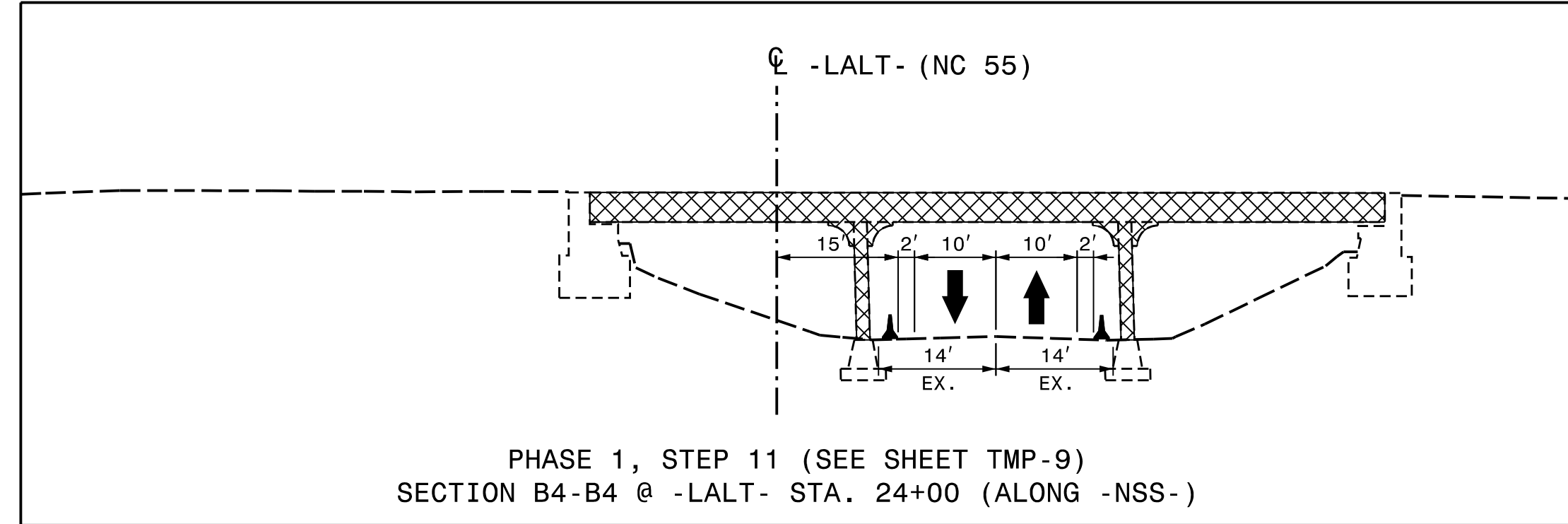
NSRR BRIDGE OVER NC 55



REVISIONS

PLOT DRIVER: NCDOT_pdf_color_eng_50.plt PENTABLE: NCDOT_tcp.tbl
 USER: erbrooks DATE: 5/12/2016 TIME: 3:58:46 PM
 FILE: c:\pwworking\tpa\d0487729\U-3308_TMP-TMP-04B.dgn

DOCUMENT NOT CONSIDERED FINAL UNLESS ALL SIGNATURES COMPLETED

APPROVED  DATE: 5/13/2016 		CSX & NSRR BRIDGE STAGING TYPICALS
---	---	------------------------------------

CULVERT UNDER -LALT- (NC 55)

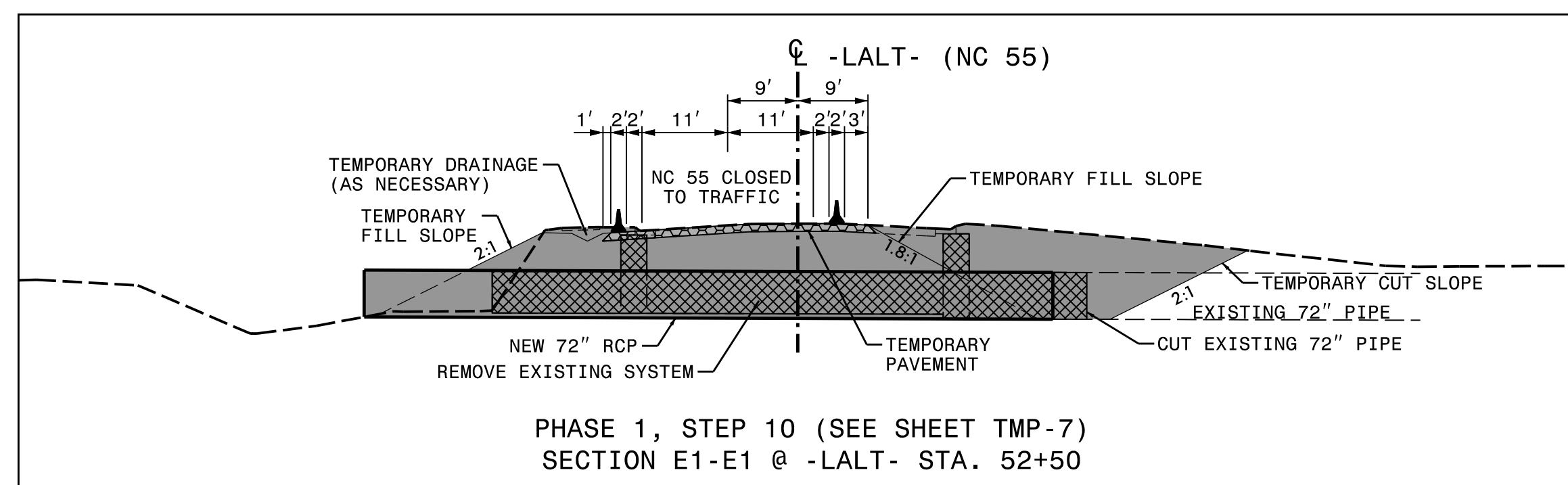

- DURING A WEEKEND OPERATION (PHASE 1, STEP 10) COMPLETE THE FOLLOWING:
1. DETOUR AND CLOSE NC 55
 2. DAM OR DIVERT EXISTING STREAM FLOW AS NECESSARY
 3. REMOVE THE EXISTING CULVERT AND DRAINAGE STRUCTURES
 4. PLACE NEW 72" RCP AND ADJACENT 30" RCP (-LALT- STA. 52+28)
 5. TEMPORARILY CONNECT NEW 72" RCP WITH EXISTING SYSTEM, AS NECESSARY
 6. REMOVE STREAM DIVERSIONS
 7. BACKFILL AND REPAIR NC 55 WITH TEMPORARY FILL SLOPES
 8. PLACE TEMPORARY PAVEMENT AT EXISTING ELEVATION AND GRADE
 9. PLACE TEMPORARY MARKINGS AND PCB
 10. REOPEN NC 55 TO 2-LANE, 2-WAY TRAFFIC PATTERN (PHASE 1, STEP 11)

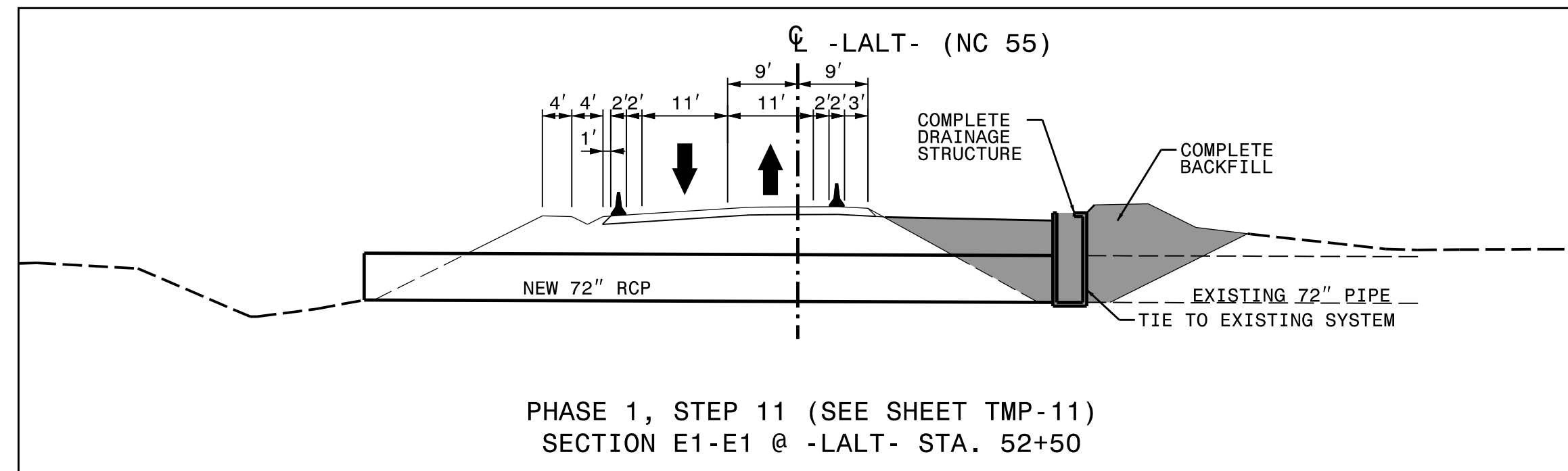

- AWAY FROM TRAFFIC AND BEHIND PCB, COMPLETE THE FOLLOWING:
1. 72" CATCH BASIN STRUCTURE (TIE TOGETHER NEW AND EXISTING SYSTEMS)
 2. BACKFILL AROUND STRUCTURE AND UP TO PROPOSED SUBGRADE

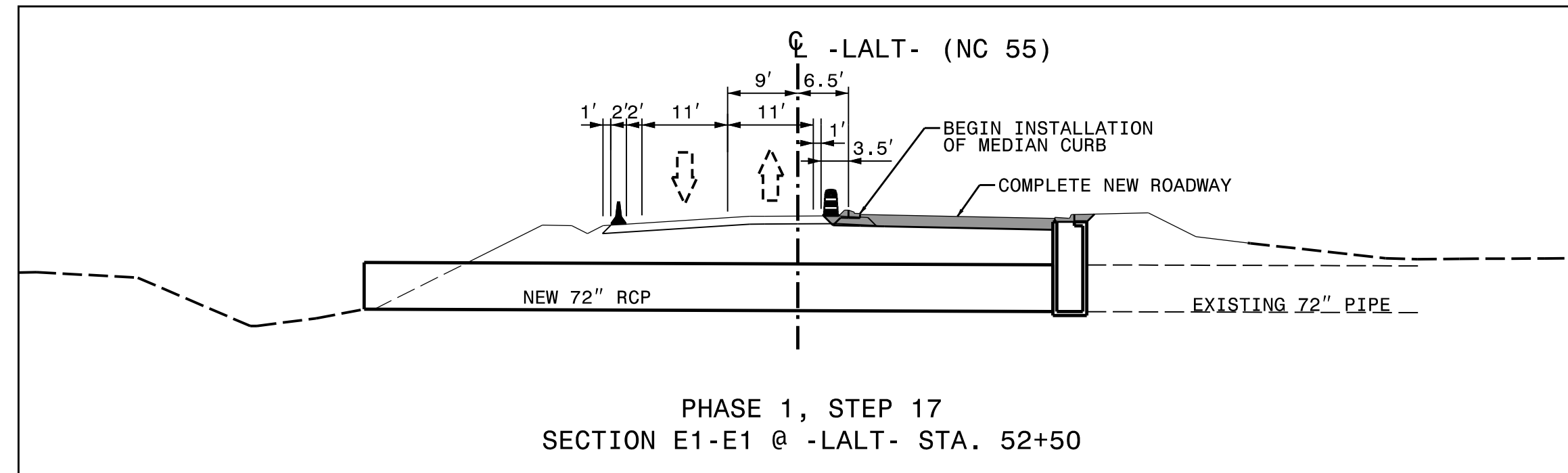

- AWAY FROM TRAFFIC AND USING LANE CLOSURES, COMPLETE THE FOLLOWING:
1. REMOVE PCB
 2. COMPLETE PROPOSED ROADWAY AND CURB AND GUTTER AS SHOWN

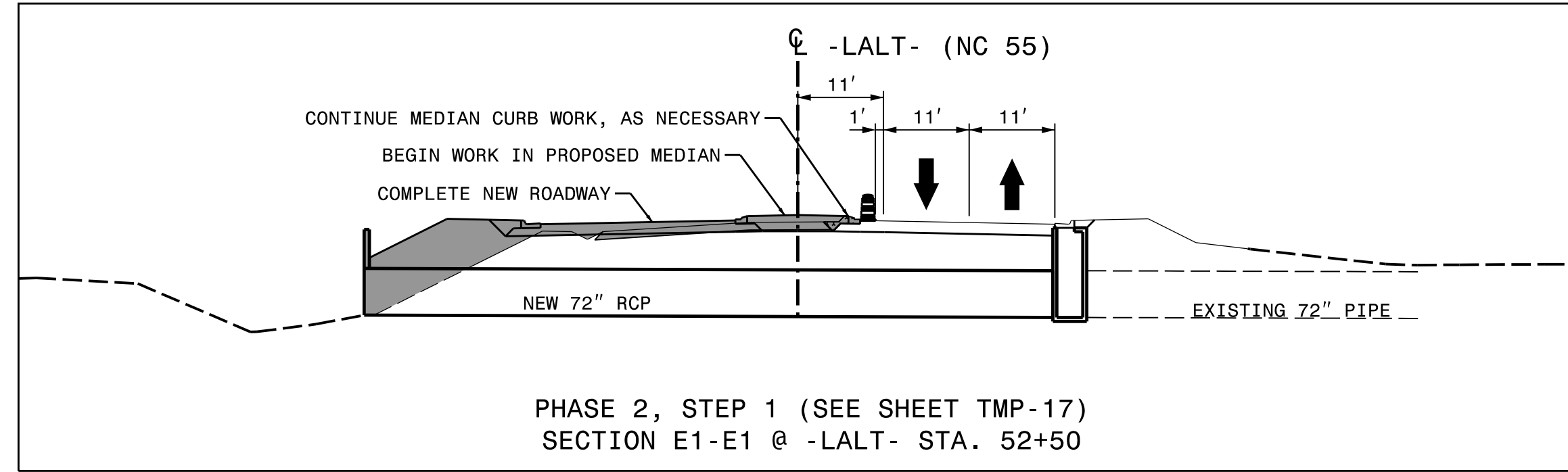

- AWAY FROM TRAFFIC AND USING LANE CLOSURES, COMPLETE THE FOLLOWING:
1. SHIFT TRAFFIC TO TEMPORARY PATTERN
 2. COMPLETE PROPOSED ROADWAY AND CURB AND GUTTER AS SHOWN

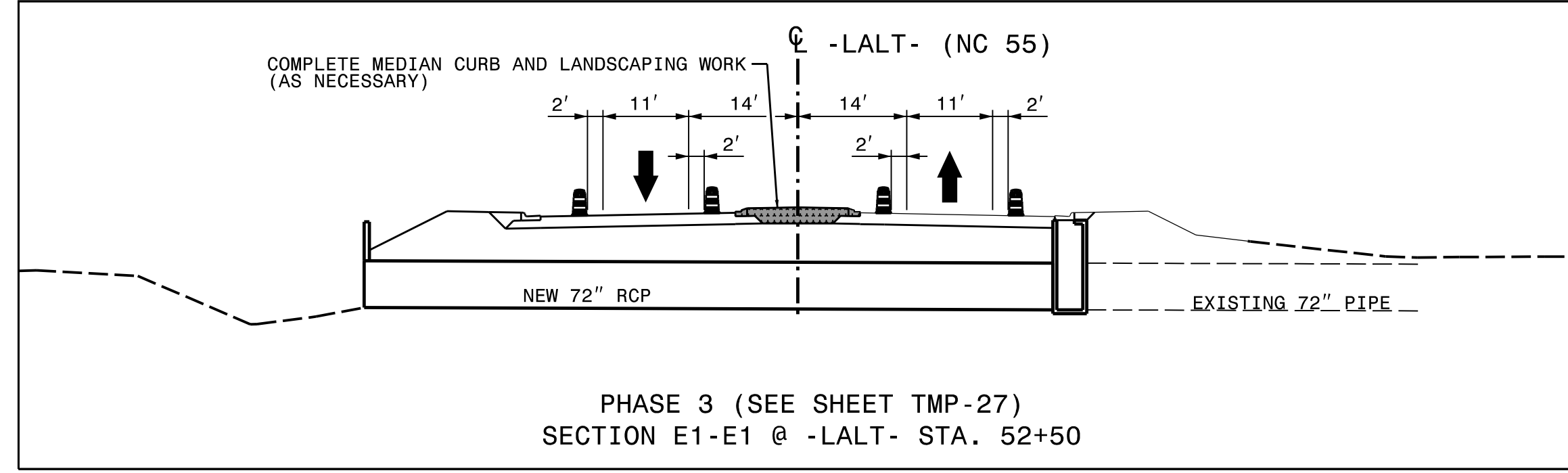



- AWAY FROM TRAFFIC AND USING LANE CLOSURES, COMPLETE THE FOLLOWING:
1. SHIFT TRAFFIC TO TEMPORARY PATTERN
 2. COMPLETE ALL REMAINING MEDIAN WORK

REVISIONS

PLOT DRIVER: NCDOT_pdf_color_eng_50.plt
 USER: erbrooks
 DATE: 5/12/2016
 TIME: 3:58:57 PM
 FILE: c:\pwworking\tpa\d0487729\U-3308_TMP-TMP-04C.dgn

DOCUMENT NOT CONSIDERED FINAL
UNLESS ALL SIGNATURES COMPLETED

APPROVED  DATE: 5/13/2016

SEAL

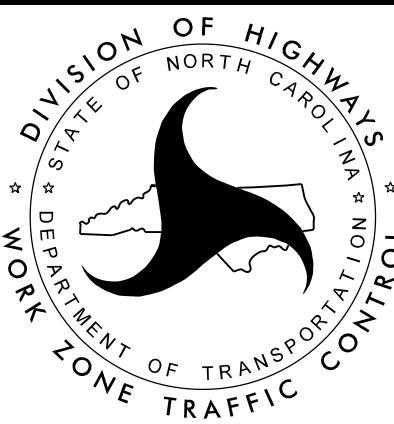

DIVISION OF HIGHWAYS
 STATE OF NORTH CAROLINA
 DEPARTMENT OF TRANSPORTATION
 WORK ZONE TRAFFIC CONTROL

-LALT- CULVERT STAGING TYPICALS

SEE SHEET TMP-4, TMP-4A, AND TMP-4B FOR SECTIONS A-A, A1-A1, A2-A2, B1-B1, B2-B2, & B3-B3

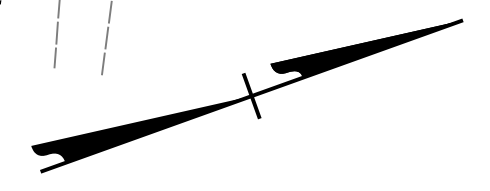

SEE SHEET TMP-2C FOR BARRICADE DETAILS

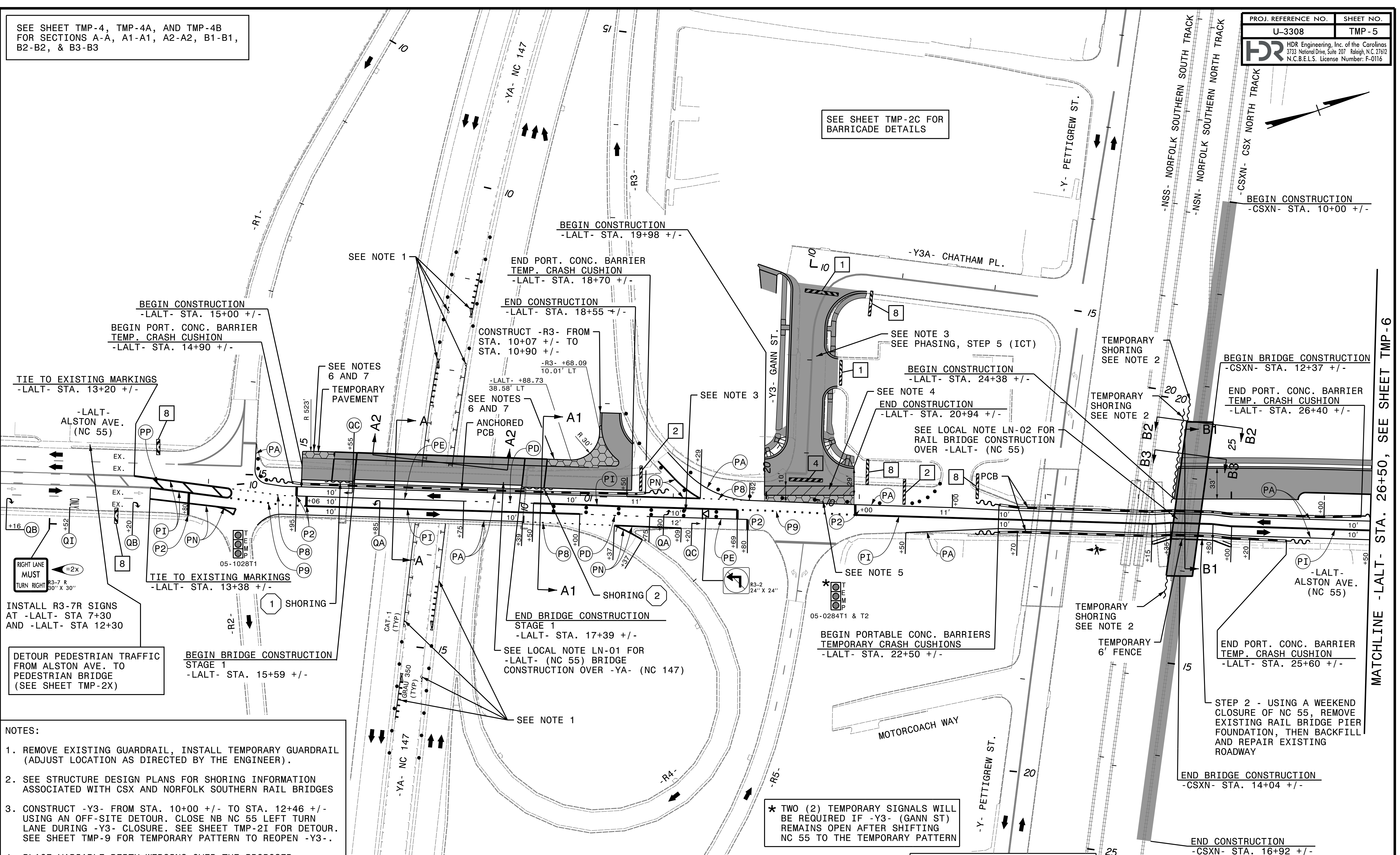

BEGIN CONSTRUCTION
-LALT- STA. 15+00 +/-
BEGIN PORT. CONC. BARRIER
TEMP. CRASH CUSHION
-LALT- STA. 14+90 +/-

TIE TO EXISTING MARKINGS
-LALT- STA. 13+20 +/-

-LALT- ALSTON AVE.
(NC 55)

TIE TO EXISTING MARKINGS
-LALT- STA. 13+38 +/-

RIGHT LANE MUST TURN RIGHT
R3-7 R
30' X 30'

INSTALL R3-7R SIGNS
AT -LALT- STA 7+30
AND -LALT- STA 12+30

DETOUR PEDESTRIAN TRAFFIC
FROM ALSTON AVE. TO
PEDESTRIAN BRIDGE
(SEE SHEET TMP-2X)

BEGIN BRIDGE CONSTRUCTION
STAGE 1
-LALT- STA. 15+59 +/-

BEGIN CONSTRUCTION
-LALT- STA. 19+98 +/-

END PORT. CONC. BARRIER
TEMP. CRASH CUSHION
-LALT- STA. 18+70 +/-

END CONSTRUCTION
-LALT- STA. 18+55 +/-

CONSTRUCT -R3- FROM
STA. 10+07 +/- TO
STA. 10+90 +/-

-R3- +68.09
10.01' LT

SEE NOTES 6 AND 7
ANCHORED
PCB

END BRIDGE CONSTRUCTION
STAGE 1
-LALT- STA. 17+39 +/-

SEE LOCAL NOTE LN-01 FOR
-LALT- (NC 55) BRIDGE
CONSTRUCTION OVER -YA- (NC 147)

BEGIN CONSTRUCTION
-LALT- STA. 24+38 +/-

END CONSTRUCTION
-LALT- STA. 20+94 +/-

SEE LOCAL NOTE LN-02 FOR
RAIL BRIDGE CONSTRUCTION
OVER -LALT- (NC 55)

BEGIN PORTABLE CONC. BARRIERS
TEMPORARY CRASH CUSHIONS
-LALT- STA. 22+50 +/-

BEGIN CONSTRUCTION
-CSXN- STA. 10+00 +/-

BEGIN BRIDGE CONSTRUCTION
-CSXN- STA. 12+37 +/-

END PORT. CONC. BARRIER
TEMP. CRASH CUSHION
-LALT- STA. 26+40 +/-

END PORT. CONC. BARRIER
TEMP. CRASH CUSHION
-LALT- STA. 25+60 +/-

STEP 2 - USING A WEEKEND
CLOSURE OF NC 55, REMOVE
EXISTING RAIL BRIDGE PIER
FOUNDATION, THEN BACKFILL
AND REPAIR EXISTING
ROADWAY

END BRIDGE CONSTRUCTION
-CSXN- STA. 14+04 +/-

END CONSTRUCTION
-CSXN- STA. 16+92 +/-

MATCHLINE -LALT- STA. 26+50, SEE SHEET TMP-6

NOTES:

1. REMOVE EXISTING GUARDRAIL, INSTALL TEMPORARY GUARDRAIL (ADJUST LOCATION AS DIRECTED BY THE ENGINEER).
2. SEE STRUCTURE DESIGN PLANS FOR SHORING INFORMATION ASSOCIATED WITH CSX AND NORFOLK SOUTHERN RAIL BRIDGES
3. CONSTRUCT -Y3- FROM STA. 10+00 +/- TO STA. 12+46 +/- USING AN OFF-SITE DETOUR. CLOSE NB NC 55 LEFT TURN LANE DURING -Y3- CLOSURE. SEE SHEET TMP-2I FOR DETOUR. SEE SHEET TMP-9 FOR TEMPORARY PATTERN TO REOPEN -Y3-.
4. PLACE VARIABLE DEPTH WEDGING OVER THE PROPOSED PAVEMENT. WEDGE FROM THE EDGE OF PROPOSED PAVEMENT (4' LT) TO 14' LT. PLACE WEDGING TO CREATE A SMOOTH TRANSITION FROM PROPOSED TO EXISTING PAVEMENT.
5. USING A LANE CLOSURE ON NC 55, REMOVE EXISTING PAVEMENT AND PLACE TEMPORARY PAVEMENT TO TIE FROM EXISTING TO PROPOSED WEDGING OVER PERMANENT PAVEMENT (4' LT TO 6' LT).
6. INSTALL PERMANENT GUARDRAIL.
7. TEMPORARILY GRADE TO DRAIN AREA, AS NECESSARY.

- | | |
|---|--|
| 1 | TEMPORARY SHORING No.1
QUANTITY = 192 SQ. FT.
FROM -LALT- STA. 15+25 +/-, 7.50' +/- LT
TO -LALT- STA. 15+57 +/-, 7.50' +/- LT |
| 2 | TEMPORARY SHORING No.2
QUANTITY = 221 SQ. FT.
FROM -LALT- STA. 17+36 +/-, 7.50' +/- LT
TO -LALT- STA. 17+70 +/-, 7.50' +/- LT |

*** TWO (2) TEMPORARY SIGNALS WILL**
BE REQUIRED IF -Y3- (GANN ST)
REMAINS OPEN AFTER SHIFTING
NC 55 TO THE TEMPORARY PATTERN

DOCUMENT NOT CONSIDERED FINAL
UNLESS ALL SIGNATURES COMPLETED

APPROVED: *R. Erskine Brooks* DATE: 5/13/2016

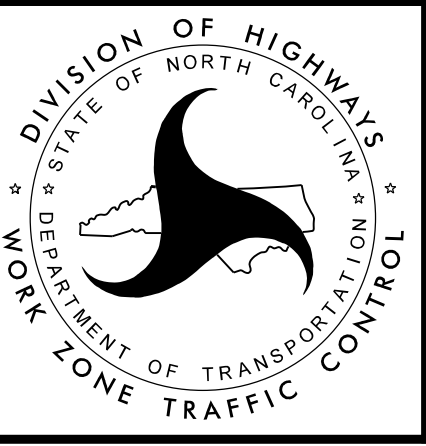

PHASE 1
STEPS 1 - 10

PLOT DRIVER: NCDOT_pdf_color_eng_50.ppt
USER: erbrooks
DATE: 5/12/2016
TIME: 3:59:08 PM
FILE: c:\pwworking\tpa\048729\U-3308_TMP-TMP-05.dgn

REVISIONS

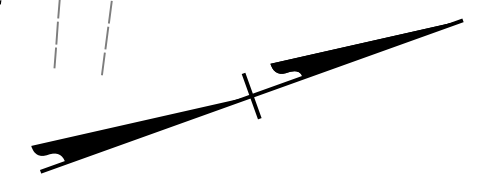

SEE SHEET TMP-2C FOR BARRICADE DETAILS

BEGIN CONSTRUCTION -R1- STA. 11+00 +/-

CLOSE AND RECONSTRUCT -R1- SEE PHASING, STEP 4A (ICT)

CONSTRUCT -R1- USING AN OFF-SITE DETOUR, SEE TMP-2G FOR DETOUR.

WEDGE AS NECESSARY TO CREATE A SMOOTH TRANSITION FROM EXISTING TO PROPOSED PAVEMENT

BEGIN CONSTRUCTION -LALT- STA. 13+50 +/-
END CONSTRUCTION -R1- STA. 14+80 +/-

-LALT- ALSTON AVE. (NC 55)

TEMPORARY PAVEMENT

MAINTAIN ANCHORED PCB

REOPEN GANN ST

-LALT- ALSTON AVE. (NC 55)

REVISIONS

MATCHLINE -LALT- STA. 26+50, SEE SHEET TMP-6

PLOT DRIVER: NCDOT_pdf_color_eng_50.plt PENTABLE: NCDOT_tcp.tbl
USER: erbrooks DATE: 5/12/2016 TIME: 3:59:19 PM
FILE: c:\pwworking\tpa\d048729\U-3308_TMP-TMP-05A.dgn

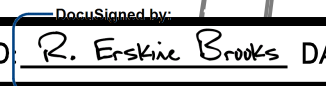
APPROVED  DATE: 5/13/2016

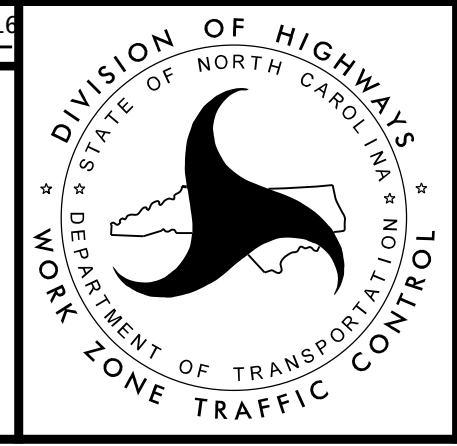
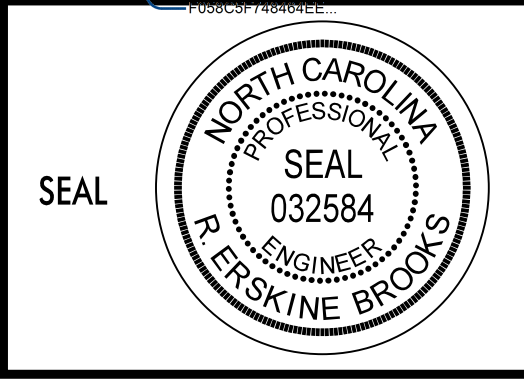

PHASE 1
STEP 4A

DOCUMENT NOT CONSIDERED FINAL
UNLESS ALL SIGNATURES COMPLETED

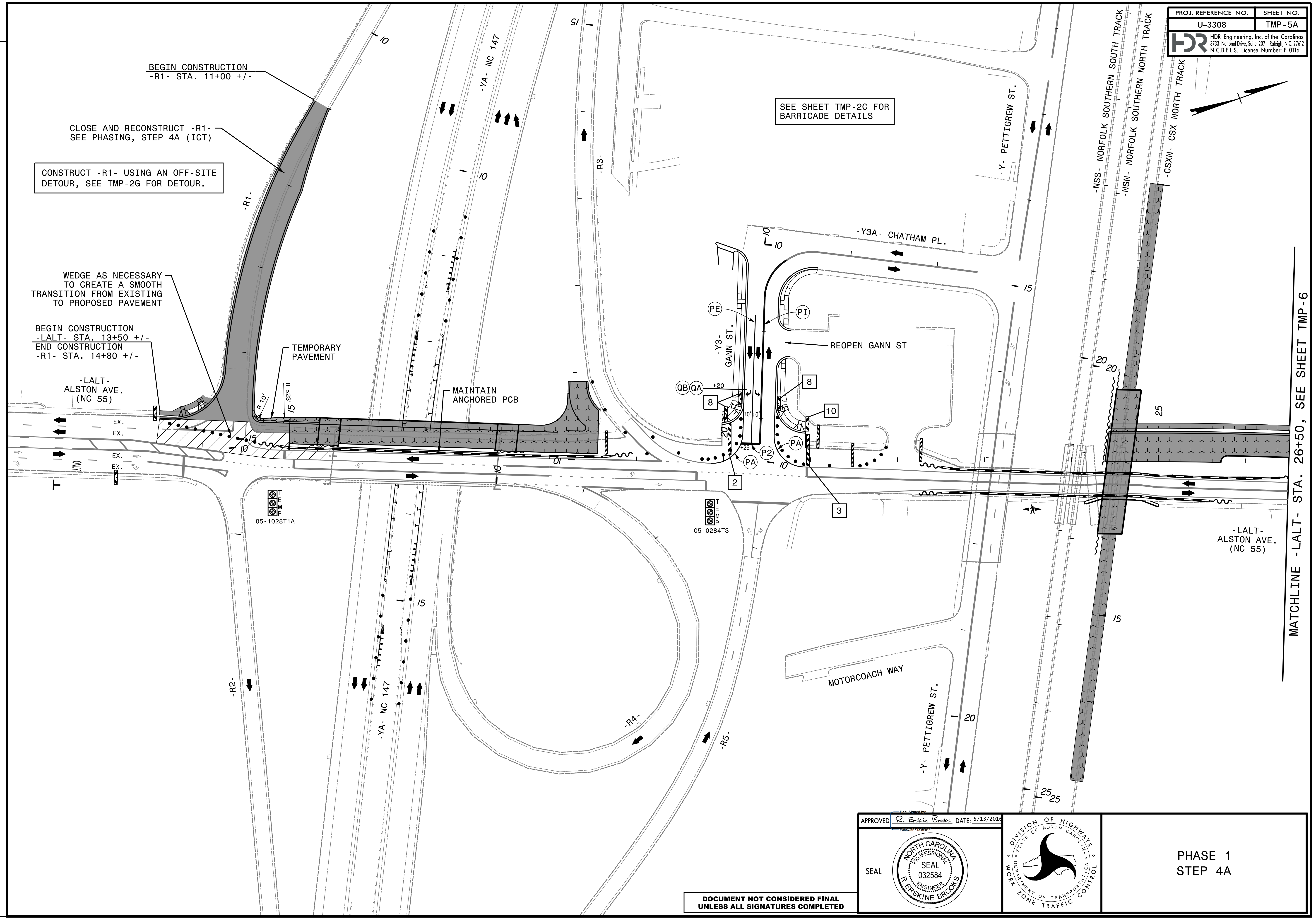

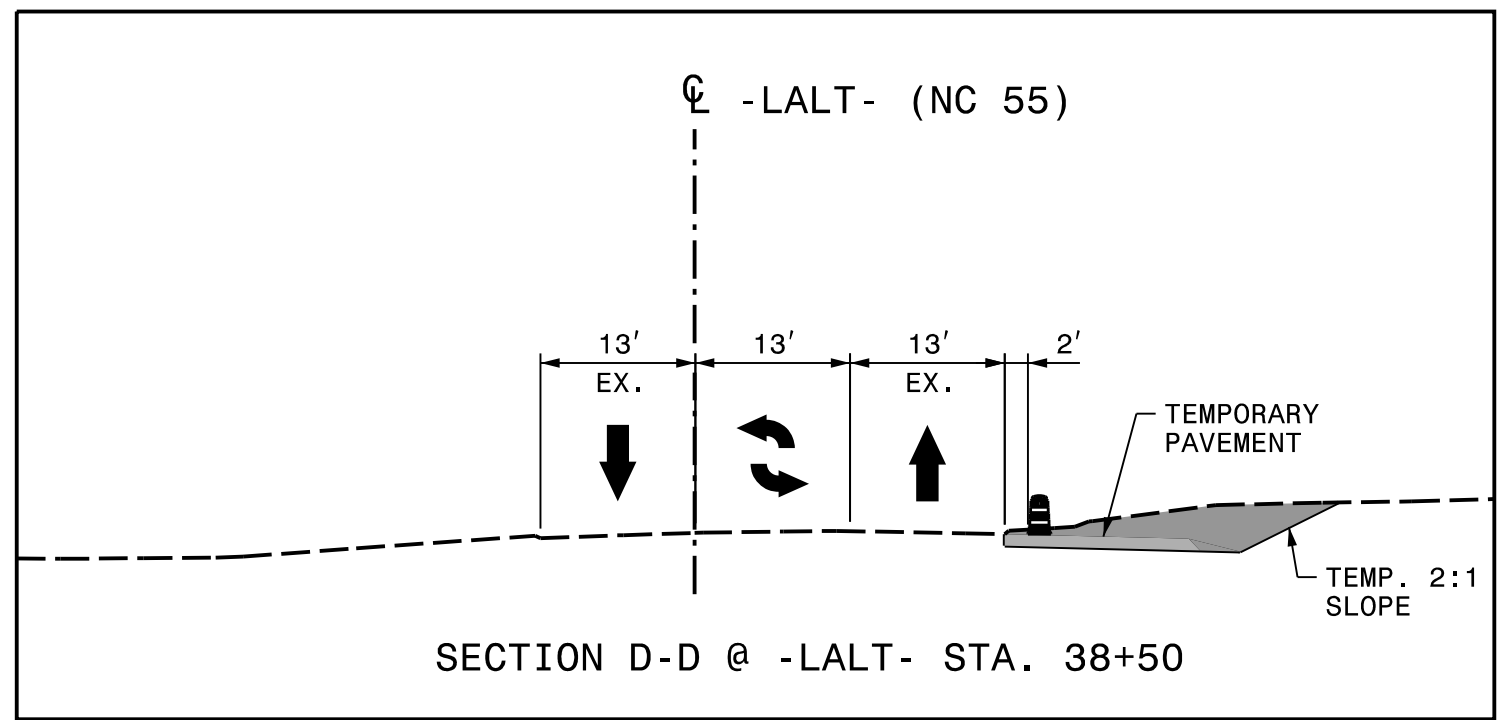
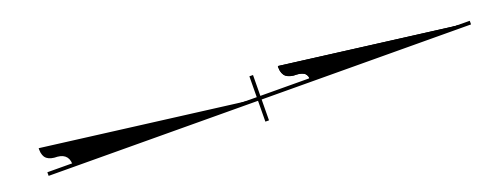

CONSTRUCT -Y1- USING AN OFF-SITE DETOUR. SEE SHEET TMP-2K FOR DETOUR.

MATCHLINE -LALT- STA. 26+50, SEE SHEET TMP-5

MATCHLINE -LALT- STA. 40+00, SEE SHEET TMP-7

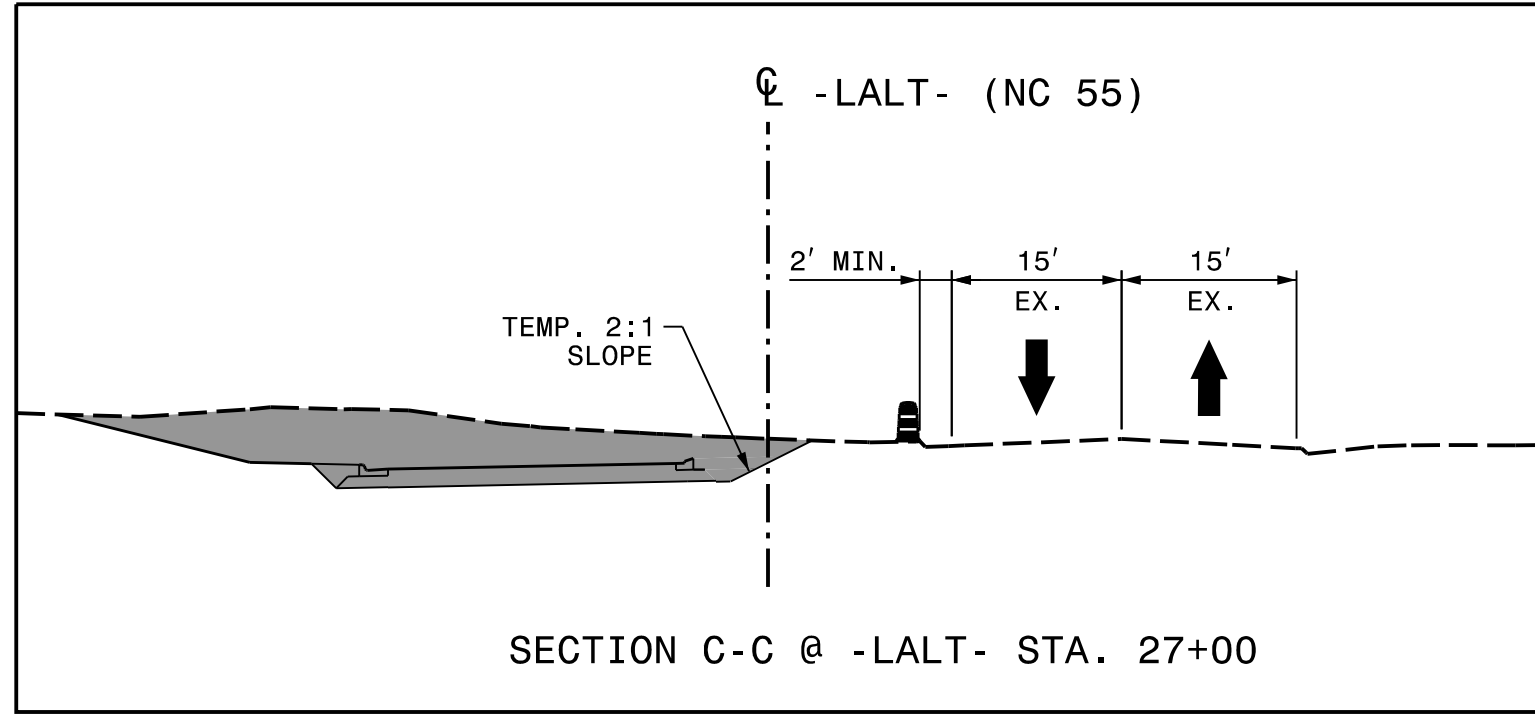
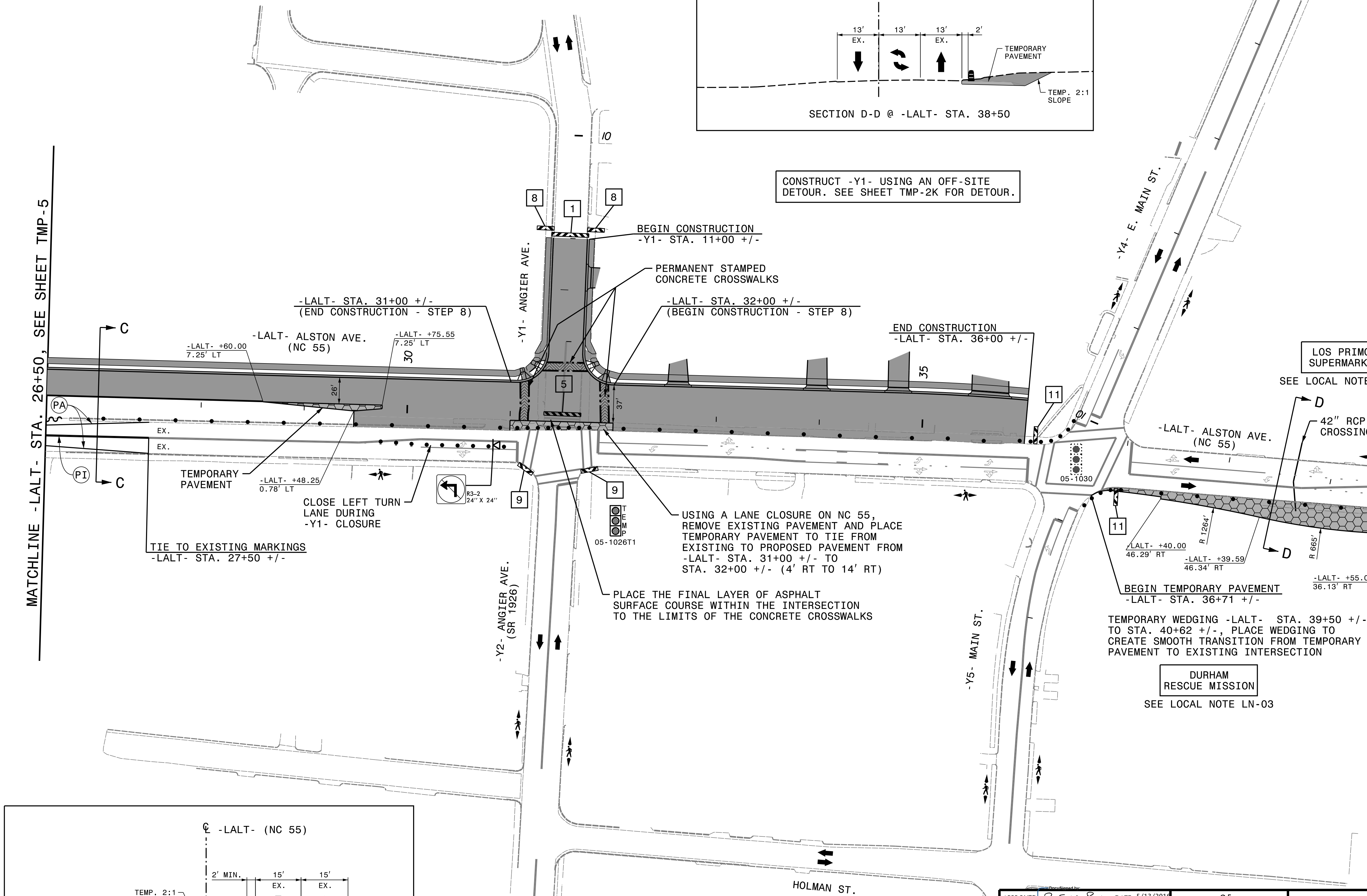

SEE SHEET TMP-2C FOR BARRICADE DETAILS

DOCUMENT NOT CONSIDERED FINAL UNLESS ALL SIGNATURES COMPLETED

APPROVED  DATE: 5/13/2016

SEAL 



PHASE 1
STEPS 1 - 10

REVISIONS

PLOT DRIVER: NCDOT_pdf_color_eng_50.plt
 USER: erbrooks
 DATE: 5/12/2016
 TIME: 3:59:32 PM
 FILE: c:\pwworking\tpa\d048729\U-3308_TMP-TMP-06.dgn

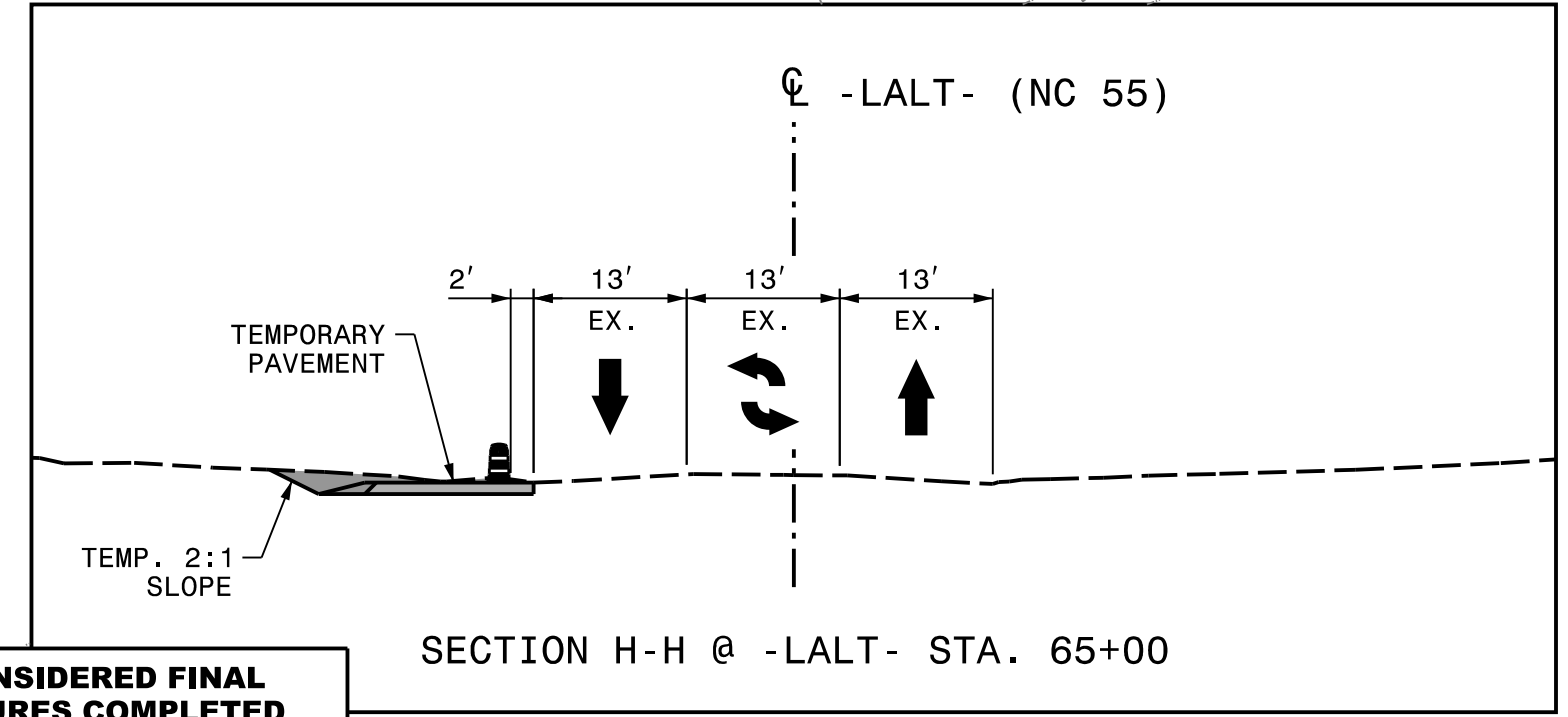
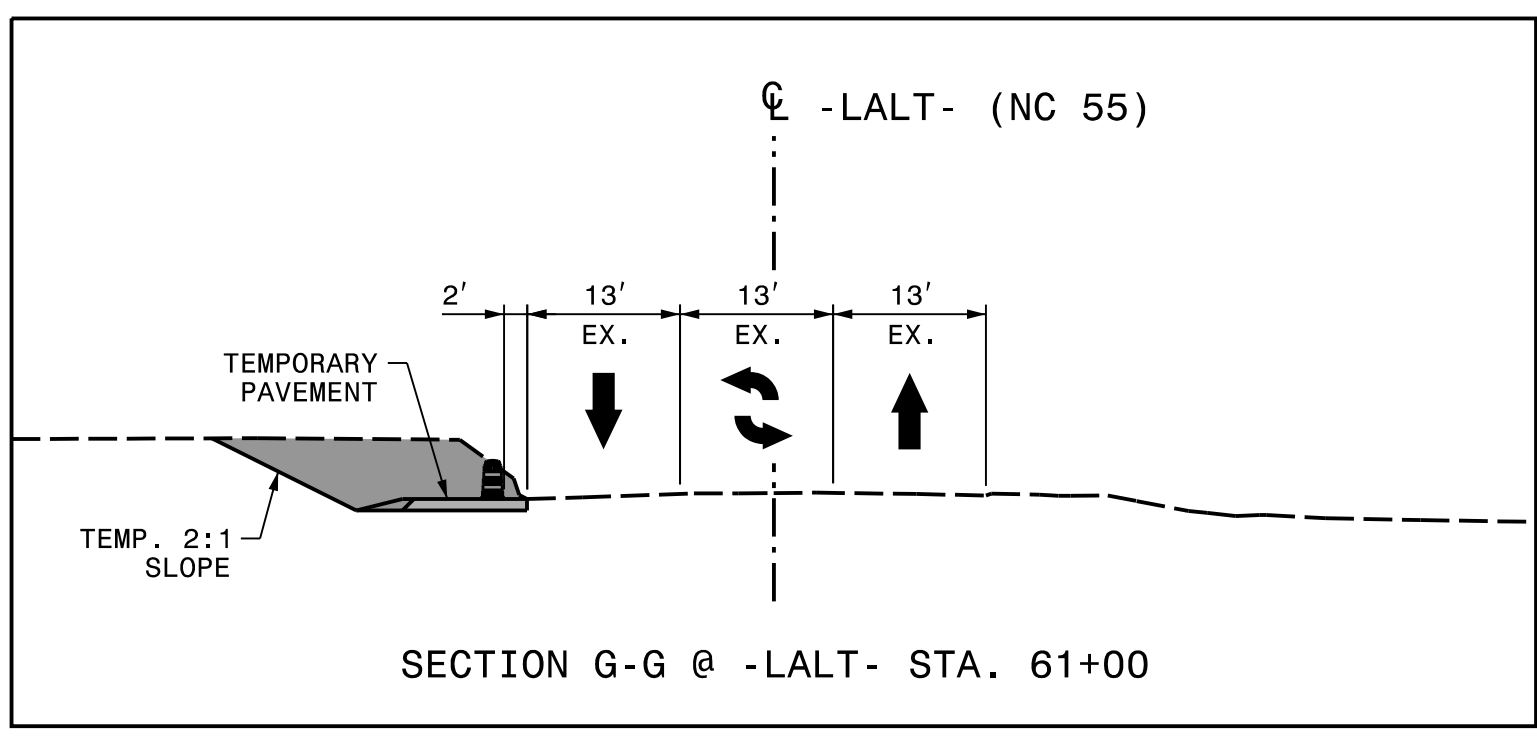
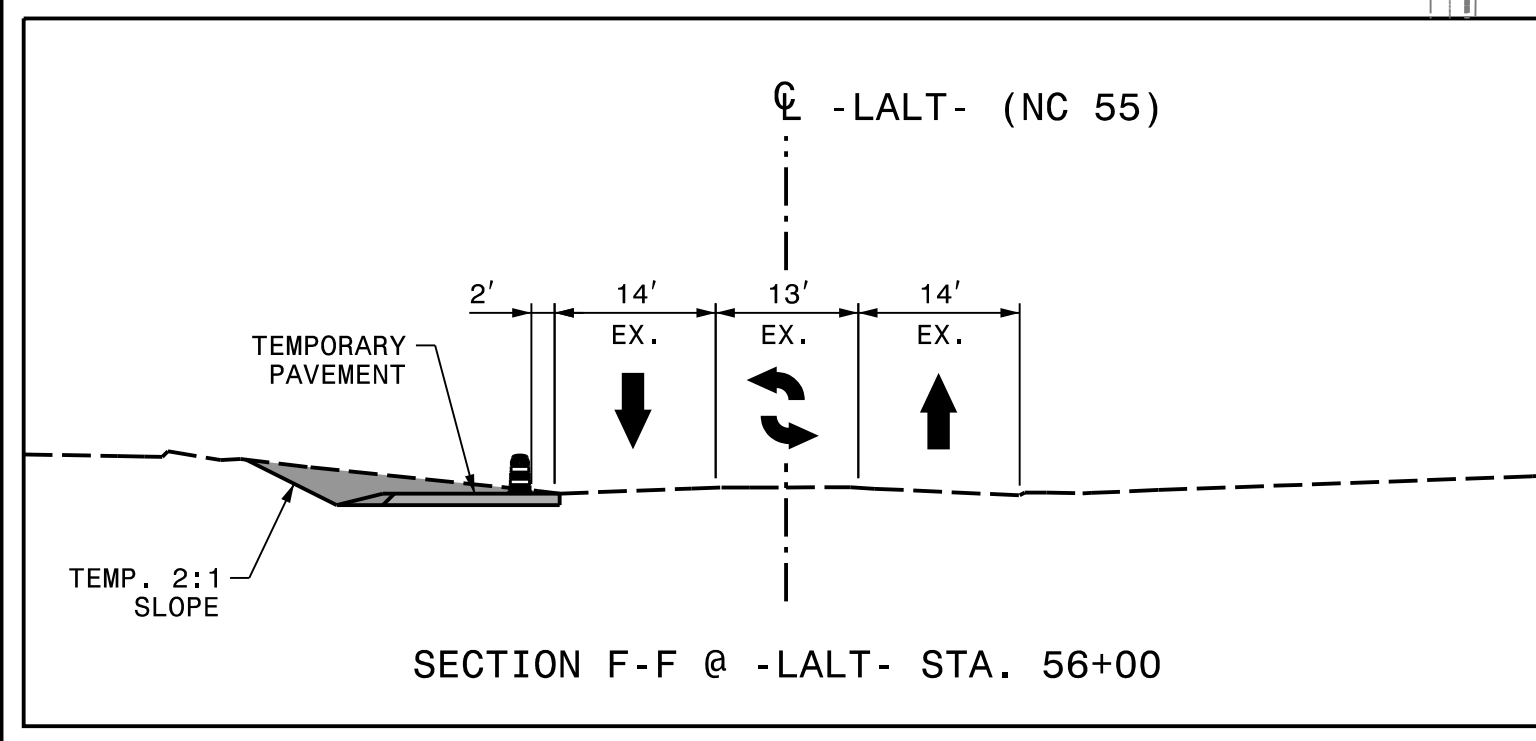
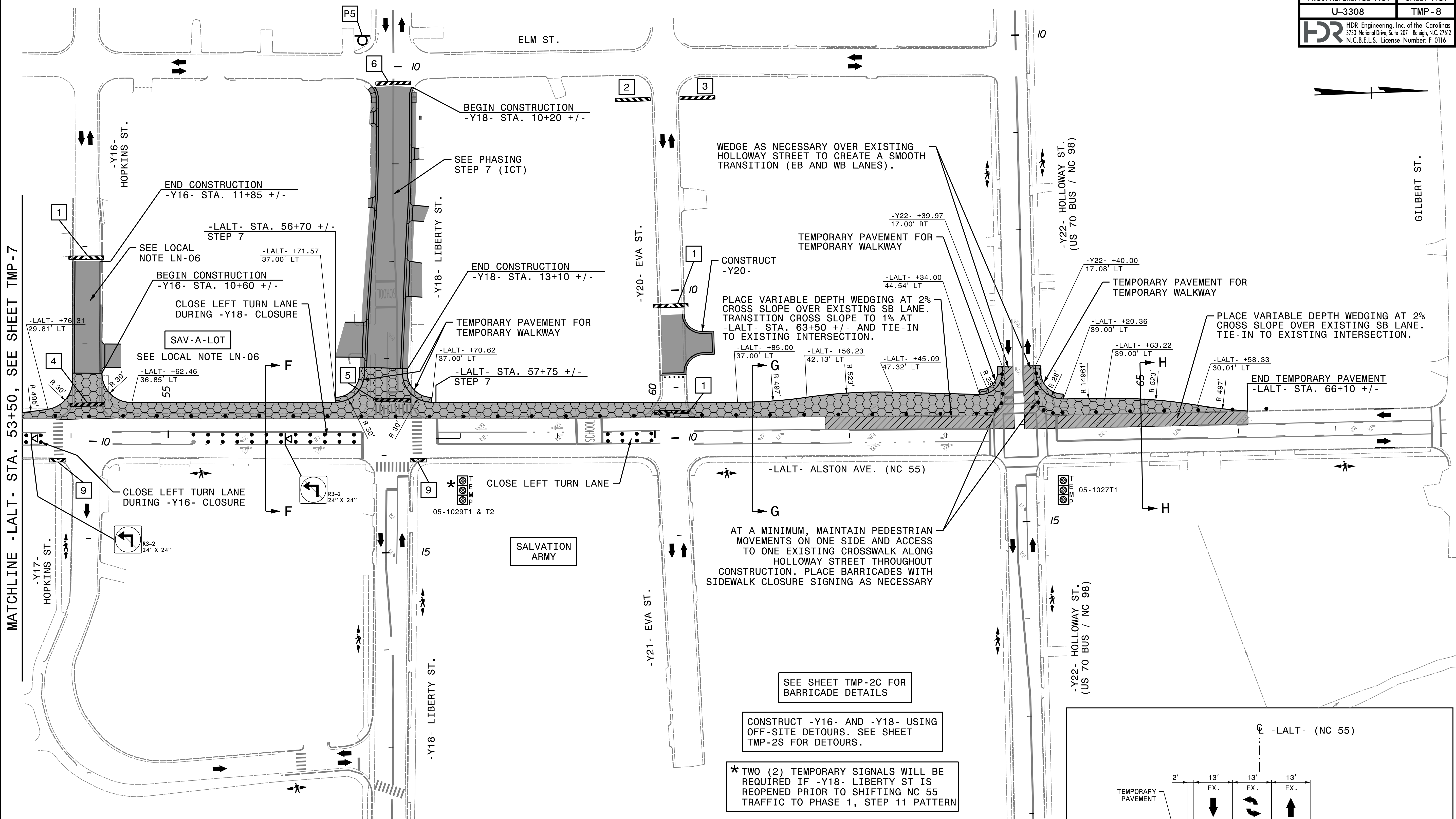
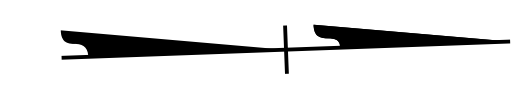

REVISIONS

PLOT DRIVER: NCDOT_pdf_color_eng_50.plt
 USER: erbrooks
 FILE: c:\pwworking\tpa\d0487729\U-3308_TMP-TMP-08.dgn
 PENTABLE: NCDOT_tcp.tbl
 DATE: 5/12/2016
 TIME: 3:59:55 PM

**DOCUMENT NOT CONSIDERED FINAL
 UNLESS ALL SIGNATURES COMPLETED**

APPROVED:  DATE: 5/13/2016

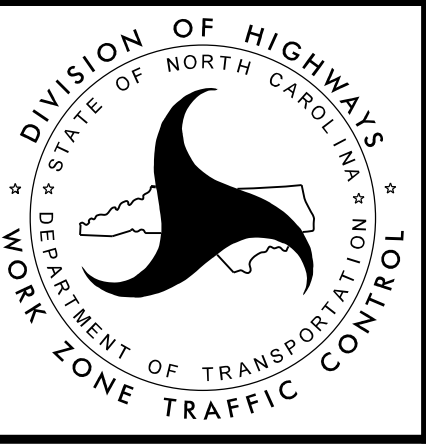

**PHASE 1
 STEPS 1 - 10**

SEE SHEET TMP-4A, AND TMP-4B FOR SECTIONS B-B, B2-B2 & B4-B4

PROJ. REFERENCE NO.	SHEET NO.
U-3308	TMP-9
 HDR Engineering, Inc. of the Carolinas 3733 National Drive, Suite 207 Raleigh, N.C. 27612 N.C.B.E.L.S. License Number: F-0116	

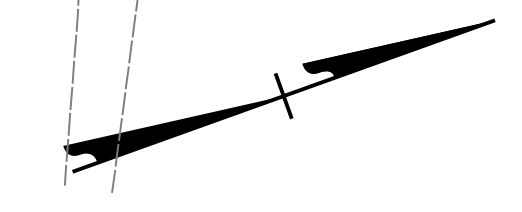

PLACE TEMPORARY MARKINGS IN THE FINAL PATTERN ON -R1- FROM STA. 11+00 +/- TO STA. 14+62 +/-

CONSTRUCT -R3- USING AN OFF-SITE DETOUR, SEE TMP-2H FOR DETOUR.
CONSTRUCT -Y- USING AN OFF-SITE DETOUR, SEE TMP-2J FOR DETOUR.

END CONSTRUCTION -R3- STA. 13+60 +/-

CONSTRUCT -Y3A- FROM STA. 10+64 +/- TO STA. 12+87 +/-

BEGIN PORTABLE CONC. BARRIER TEMPORARY CRASH CUSHIONS -LALT- STA. 21+30 +/-

BEGIN CONSTRUCTION -NSS- STA. 10+00 +/-
-NSN- STA. 10+00 +/-

BEGIN CONSTRUCTION -R3- STA. 10+90 +/-

SEE PHASING STEP 19 (ICT)

ADJUST CRASH CUSHION AS NECESSARY TO COMPLETE -LALT- WORK

BEGIN BRIDGE CONSTRUCTION -Y- STA. 16+27 +/-

TIE TO PCB PLACED IN PHASE 1, STEP 2 -LALT- STA. 22+70 +/-

BEGIN BRIDGE CONSTRUCTION -NSS- STA. 20+37 +/-
-NSN- STA. 20+28 +/-

END CONSTRUCTION -LALT- STA. 24+39 +/-

ALL RAIL TRAFFIC ON TEMPORARY ALIGNMENT AND STRUCTURE

-LALT- ALSTON AVE. (NC 55)

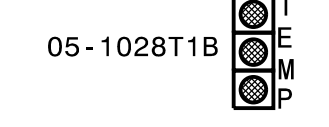

ADJUST PCB AS NECESSARY TO COMPLETE ROADWAY RECONSTRUCTION

END CONSTRUCTION -LALT- STA. 19+98 +/- STEP 19

BEGIN CONSTRUCTION -LALT- STA. 20+94 +/-

END BRIDGE CONSTRUCTION -Y- STA. 17+05 +/-

-LALT- ALSTON AVE. (NC 55)

END BRIDGE CONSTRUCTION -NSS- STA. 21+21 +/-
-NSN- STA. 21+11 +/-

SEE LOCAL NOTE LN-02 FOR -Y- AND RAIL BRIDGE CONSTRUCTION OVER -LALT- (NC 55)

BEGIN CONSTRUCTION -LALT- STA. 18+55 +/- STEP 14

BEGIN CONSTRUCTION -Y- STA. 17+85 +/-

MATCHLINE -Y- STA. 20+50
SEE THIS SHEET

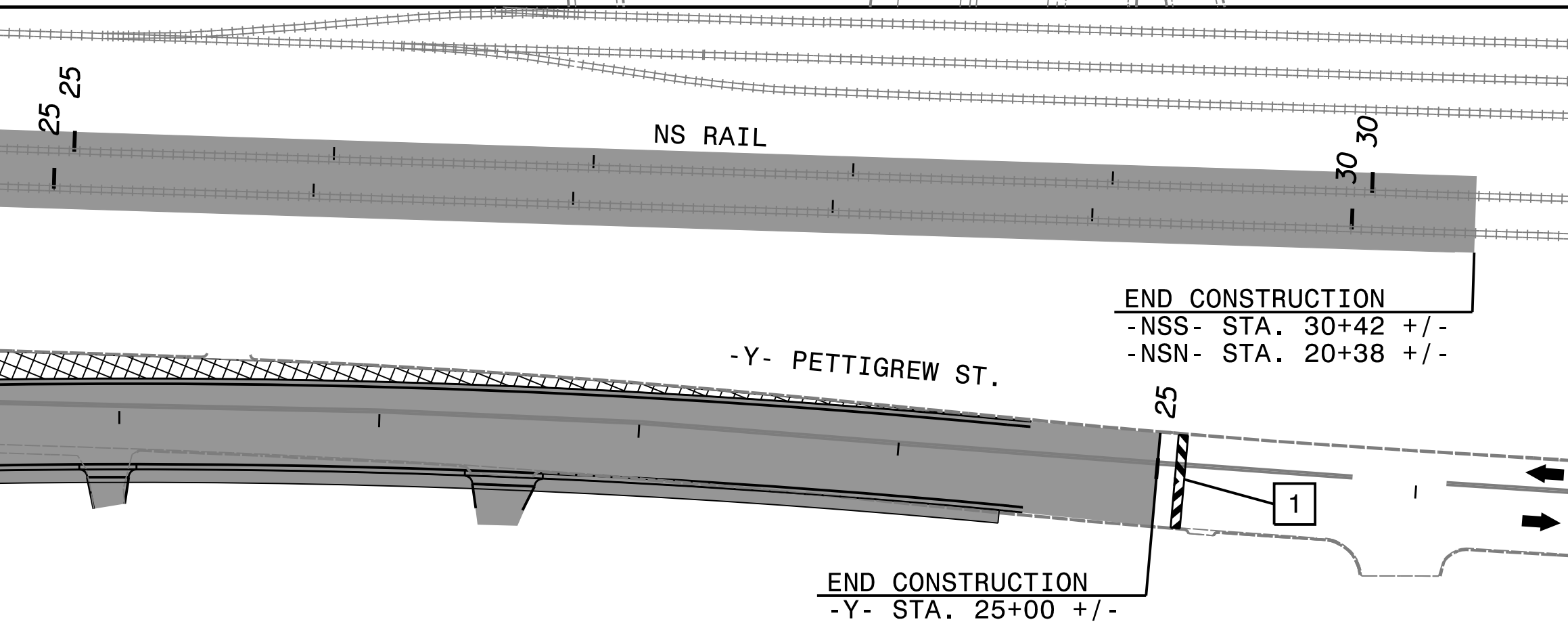

END CONSTRUCTION -NSS- STA. 30+42 +/-
-NSN- STA. 20+38 +/-

END CONSTRUCTION -Y- STA. 25+00 +/-

MATCHLINE -Y- STA. 20+50
SEE THIS SHEET

SEE SHEET TMP-2C FOR BARRICADE DETAILS

MATCHLINE -LALT- STA. 26+50, SEE SHEET TMP-10

REVISIONS

PLOT DRIVER: NCDOT_pdf_color_eng_50.plt
USER: erbrooks
DATE: 5/12/2016
TIME: 4:00:08 PM
FILE: c:\pwworking\tpa\d048729\U-3308_TMP-TMP-09.dgn

DOCUMENT NOT CONSIDERED FINAL UNLESS ALL SIGNATURES COMPLETED

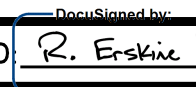
APPROVED  DATE: 5/13/2016

SEAL

WORKING WITH THE

 DIVISION OF HIGHWAYS
 NORTH CAROLINA
 DEPARTMENT OF TRANSPORTATION
 WORKING WITH THE
 STATE ZONE TRAFFIC CONTROL

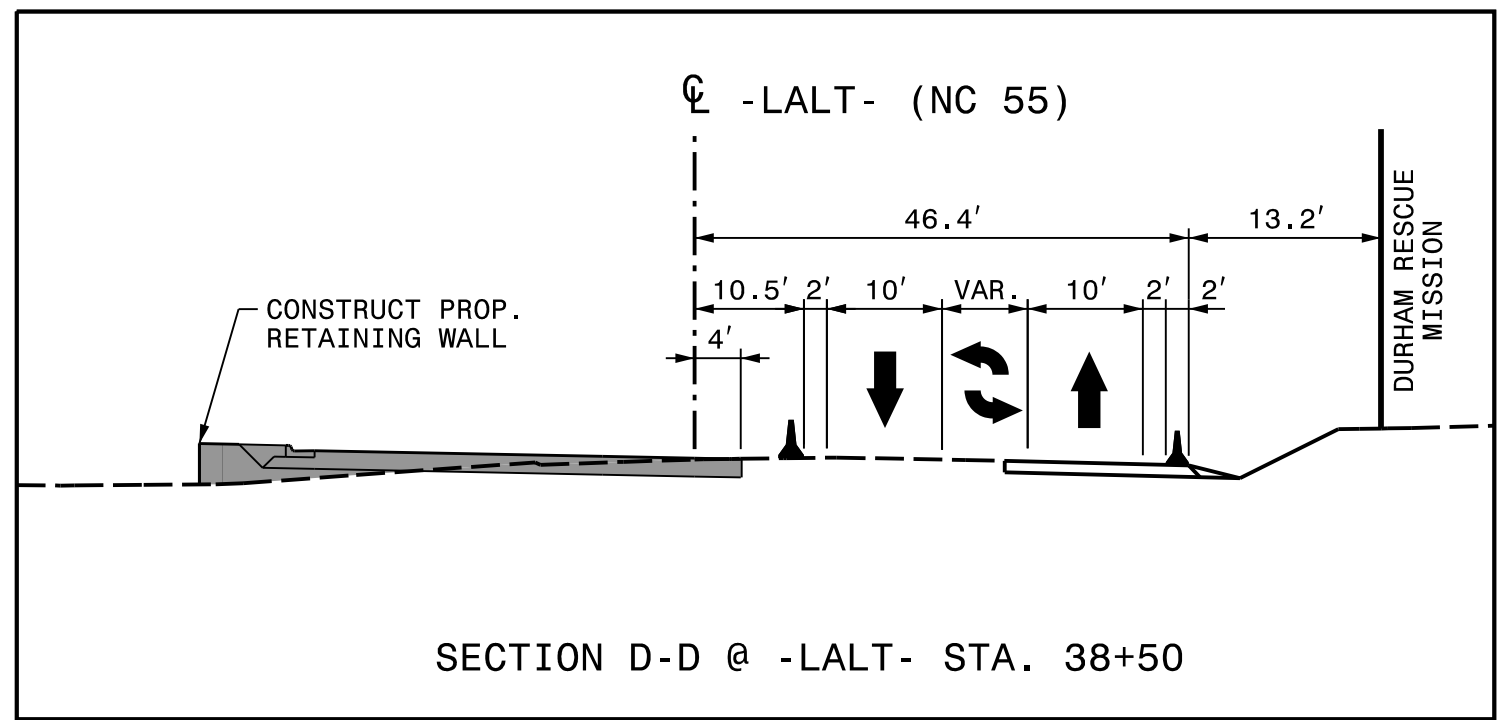
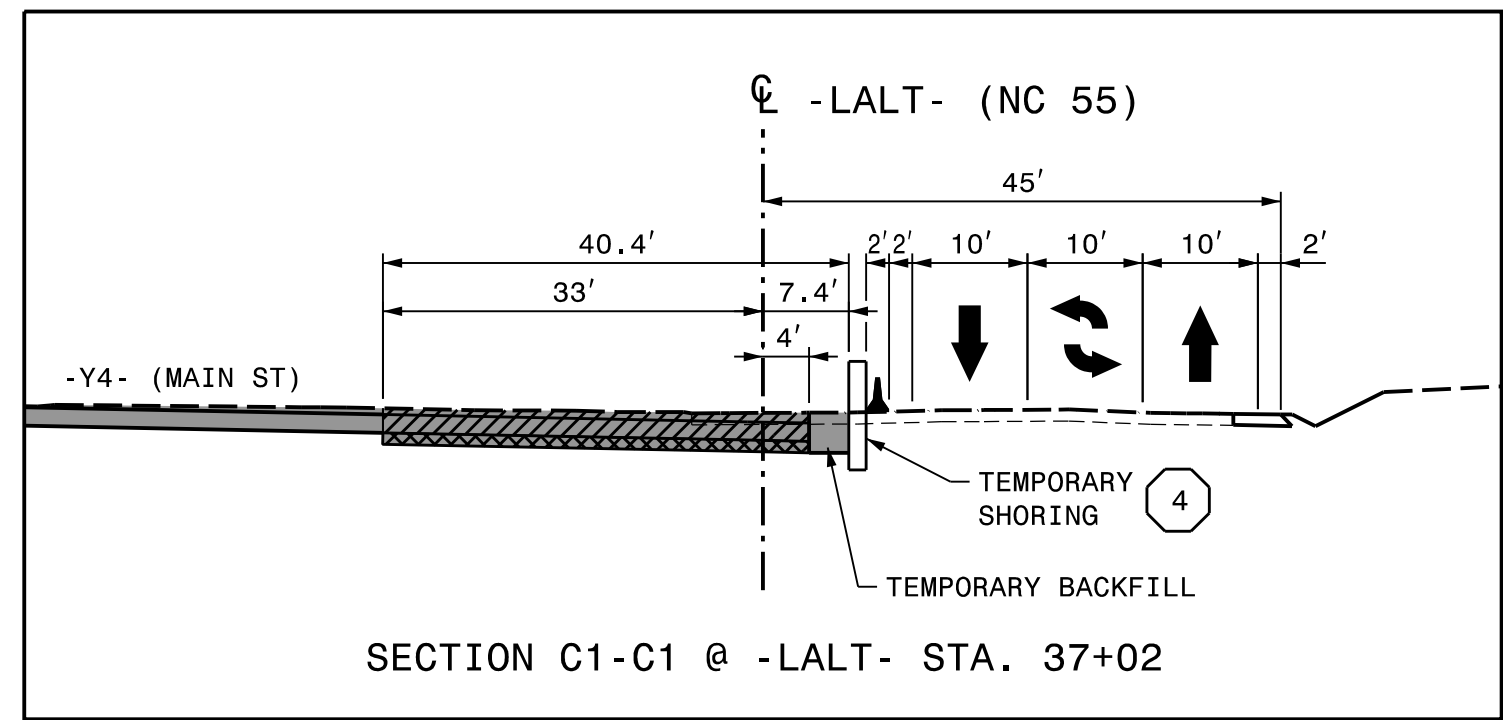
PHASE 1
STEPS 11 - 20

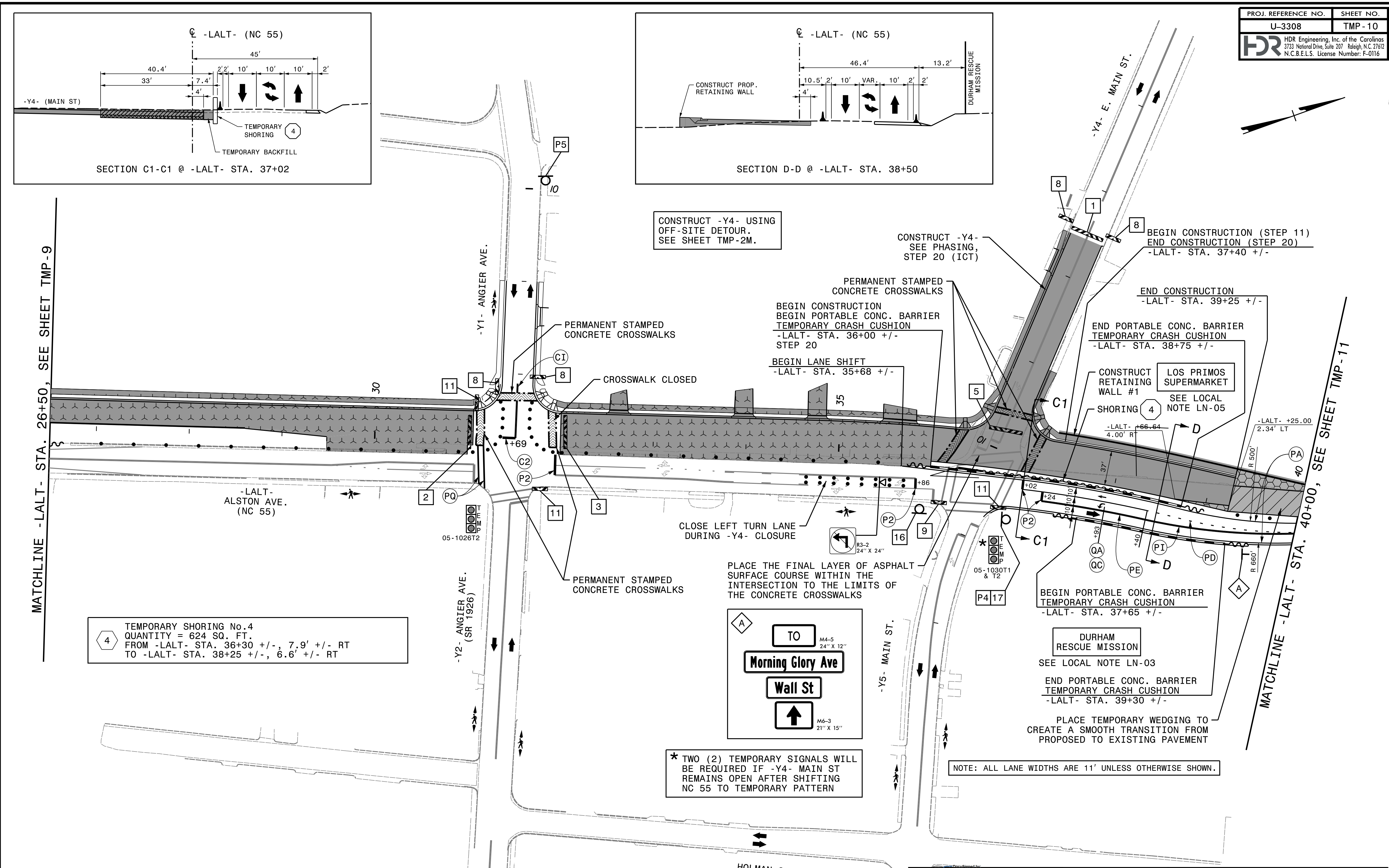

MATCHLINE -LALT- STA. 26+50, SEE SHEET TMP-9

MATCHLINE -LALT- STA. 40+00, SEE SHEET TMP-11



4 TEMPORARY SHORING No.4
 QUANTITY = 624 SQ. FT.
 FROM -LALT- STA. 36+30 +/-, 7.9' +/- RT
 TO -LALT- STA. 38+25 +/-, 6.6' +/- RT

* TWO (2) TEMPORARY SIGNALS WILL BE REQUIRED IF -Y4- MAIN ST REMAINS OPEN AFTER SHIFTING NC 55 TO TEMPORARY PATTERN

NOTE: ALL LANE WIDTHS ARE 11' UNLESS OTHERWISE SHOWN.

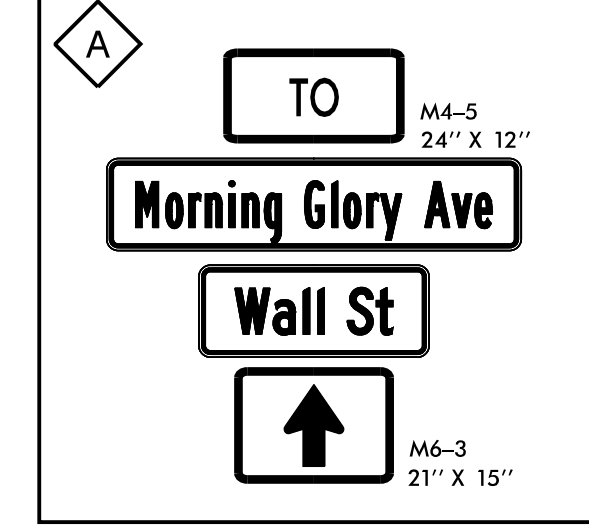

SEE SHEET TMP-2C FOR BARRICADE DETAILS

DOCUMENT NOT CONSIDERED FINAL UNLESS ALL SIGNATURES COMPLETED

APPROVED  DATE: 5/13/2016

SEAL

DIVISION OF HIGHWAYS
 STATE OF NORTH CAROLINA
 DEPARTMENT OF TRANSPORTATION
 WORK ZONE TRAFFIC CONTROL



PHASE 1
 STEPS 11 - 20

PLOT DRIVER: NCDOT_pdf_color_eng_50.plt
 USER: erbrooks
 DATE: 5/12/2016
 TIME: 4:00:20 PM
 FILE: c:\pwworking\tpa\d0487729\U-3308_TMP-TMP-10.dgn

REVISIONS

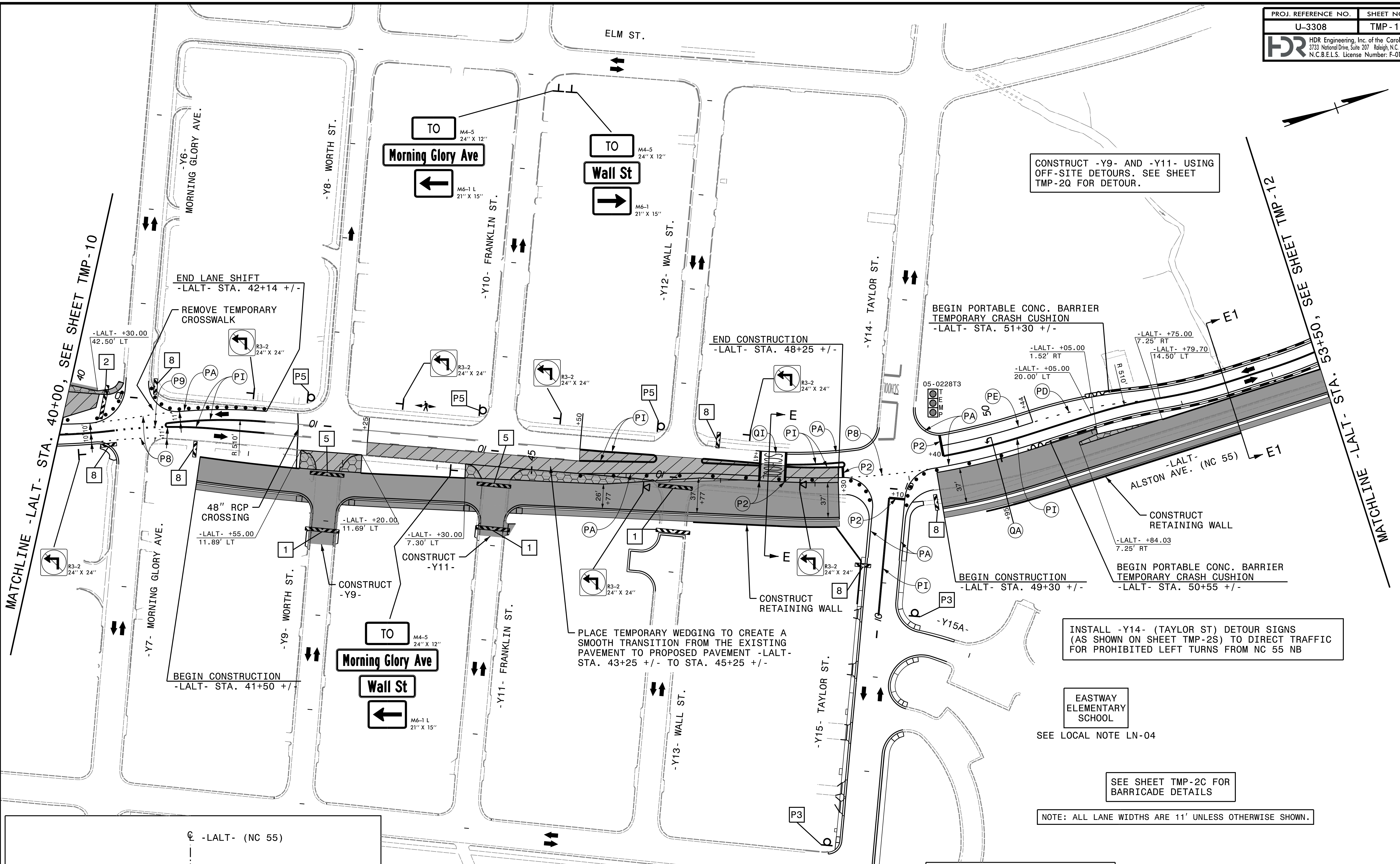
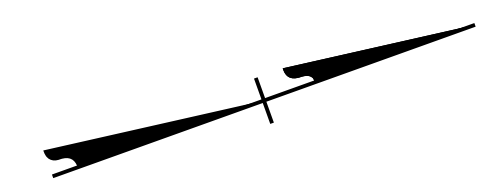

REVISIONS

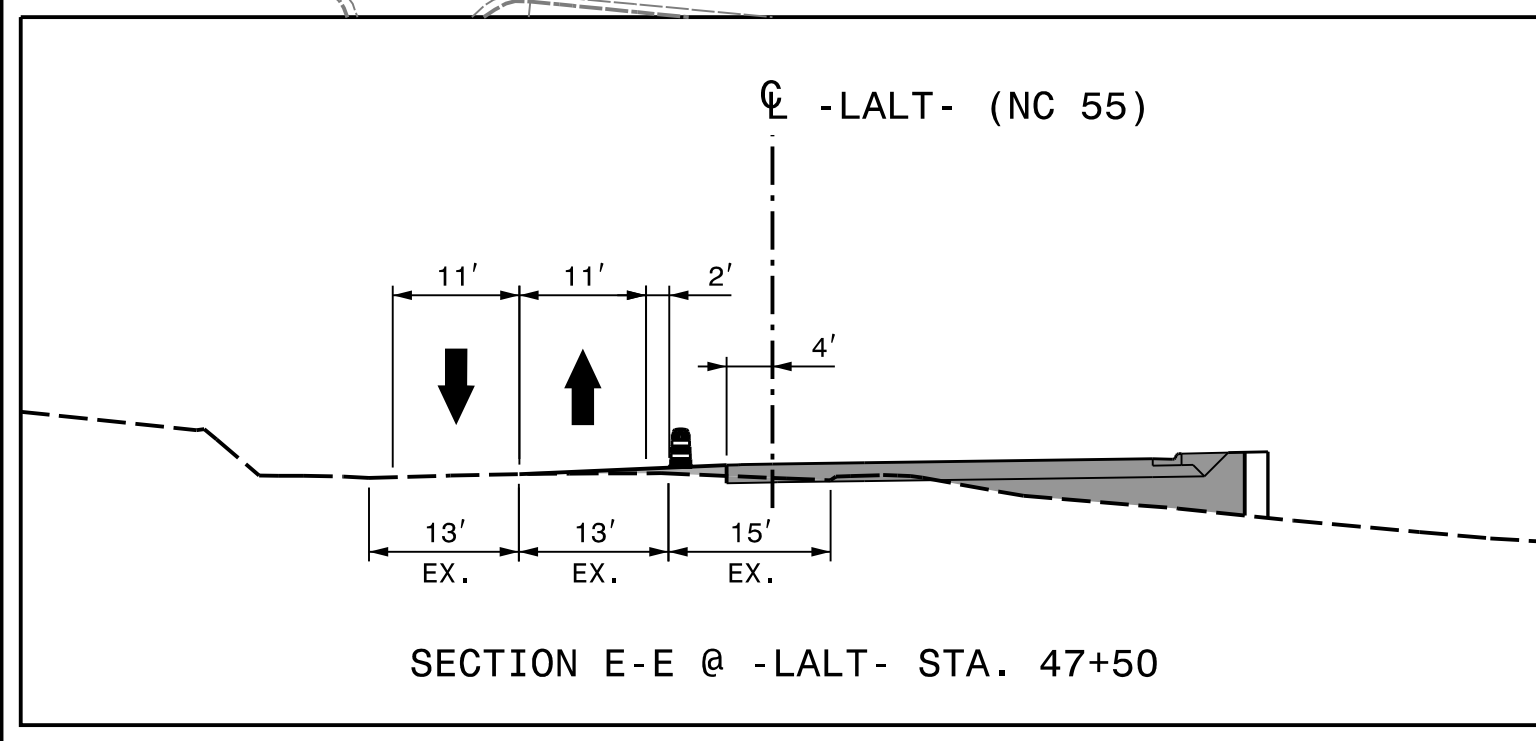

SEE SHEET TMP-4C FOR SECTION E1-E1

DOCUMENT NOT CONSIDERED FINAL UNLESS ALL SIGNATURES COMPLETED

APPROVED *R. Erskine Brooks* DATE: 5/13/2016

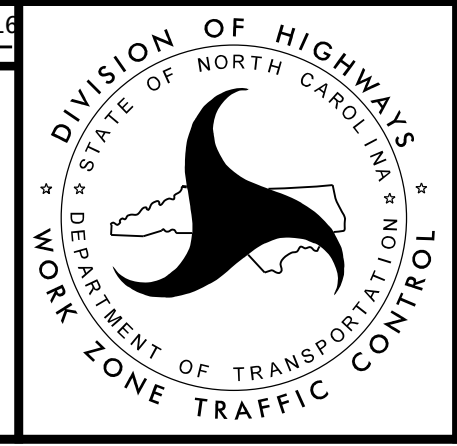

PHASE 1
STEPS 11 - 20

PLOT DRIVER: NCDOT_pdf_color_eng_50.plt
 USER: erbrooks
 DATE: 5/12/2016
 TIME: 4:00:35 PM
 FILE: c:\pwworking\tpa\d048729\U-3308_TMP-TMP-11.dgn

- NOTES:
1. USING A LANE CLOSURE ALONG NC 55, REMOVE EXISTING PAVEMENT AND PLACE TEMPORARY PAVEMENT TO TIE FROM EXISTING TO PERMANENT ELEVATION ACROSS INTERSECTION FROM -LALT- STA. 56+70 +/- TO STA. 57+75 +/- (13' LT - 4' LT)
 2. PLACE VARIABLE DEPTH WEDGING OVER PROPOSED PAVEMENT FROM THE EDGE OF TEMPORARY PAVEMENT (4' LT) TO THE PROPOSED -LALT- CENTERLINE. PLACE WEDGING TO CREATE A SMOOTH TRANSITION FROM PROPOSED TO EXIST PAVEMENT AND TO CREATE POSITIVE DRAINAGE WITHIN THE INTERSECTION.
 3. INSTALL -Y16-/-Y17- (HOPKINS ST) AND -Y18- (LIBERTY ST) DETOUR SIGNS (AS SHOWN ON SHEET TMP-2S AND TMP-2T) TO DIRECT TRAFFIC FOR PROHIBITED LEFT TURNS FROM NC 55.

* TWO (2) TEMPORARY SIGNALS WILL BE REQUIRED IF -Y18- LIBERTY ST REMAINS OPEN AFTER SHIFTING NC 55 TO TEMPORARY PATTERN

TEMPORARY SHORING No.3
 QUANTITY = 585 SQ. FT.
 FROM -LALT- STA. 59+80 +/-, 6.0'-9.0' +/- LT
 TO -LALT- STA. 61+75 +/-, 6.0'-9.0' +/- LT

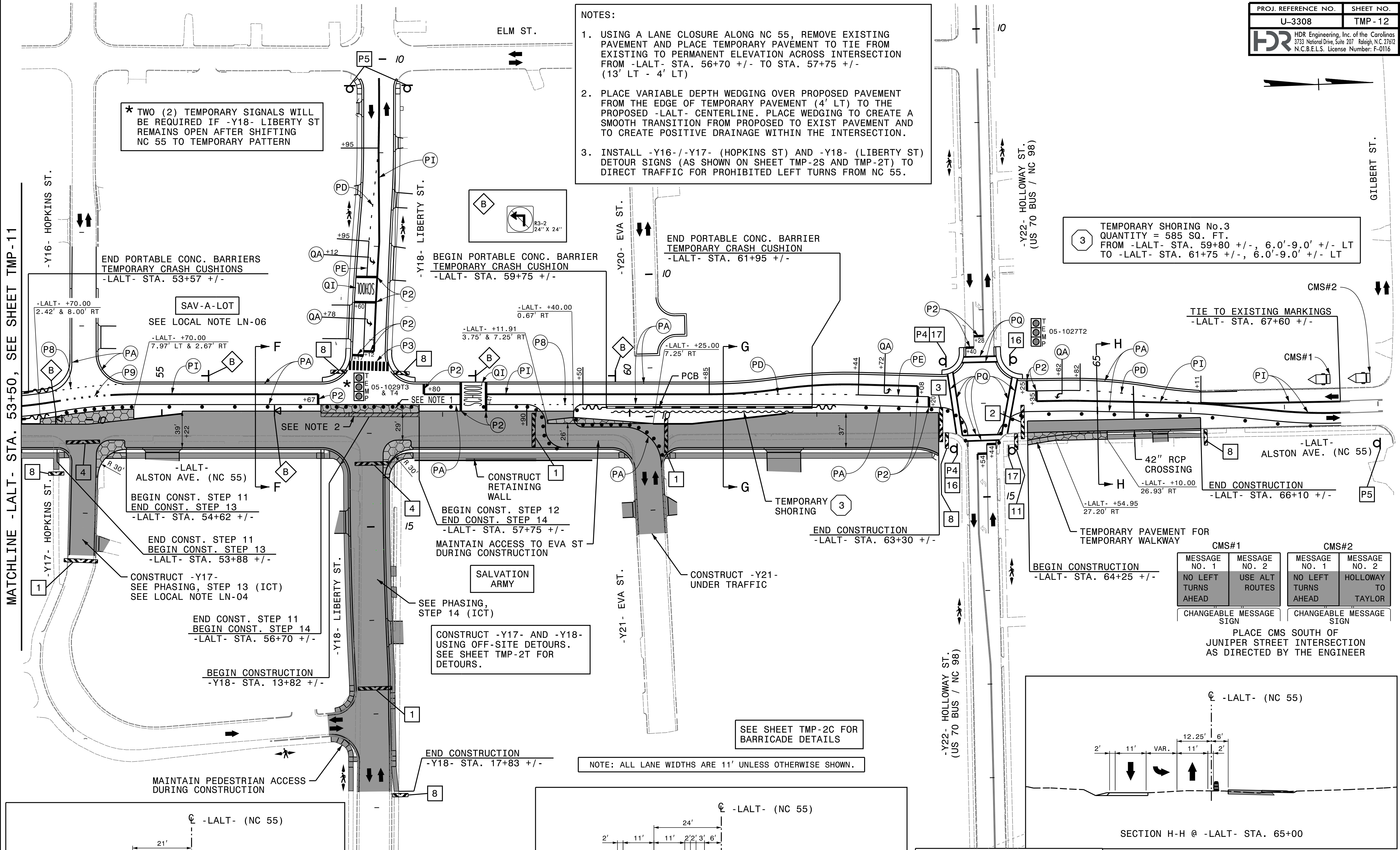

CMS#1		CMS#2	
MESSAGE NO. 1	MESSAGE NO. 2	MESSAGE NO. 1	MESSAGE NO. 2
NO LEFT TURNS AHEAD	USE ALT ROUTES	NO LEFT TURNS AHEAD	HOLLOWAY TO TAYLOR

PLACE CMS SOUTH OF JUNIPER STREET INTERSECTION AS DIRECTED BY THE ENGINEER

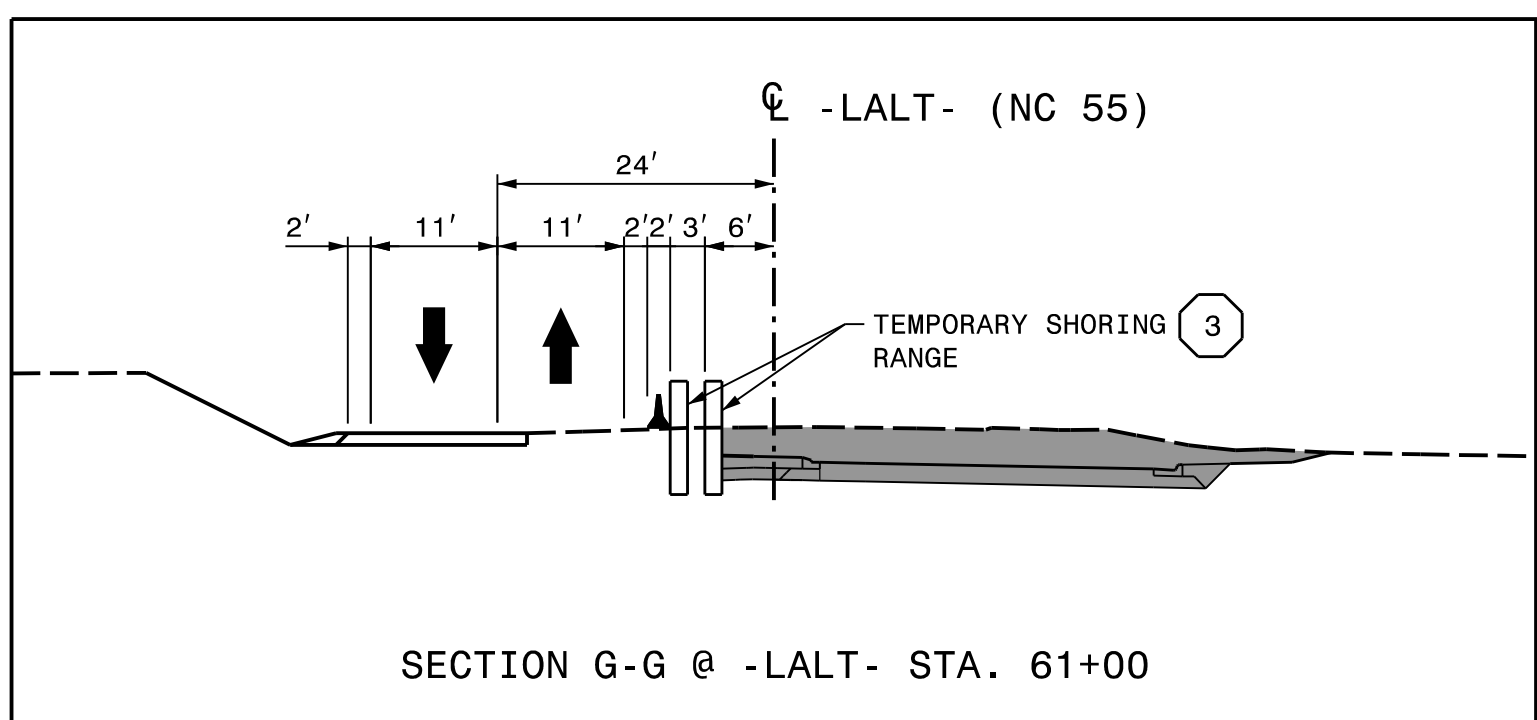
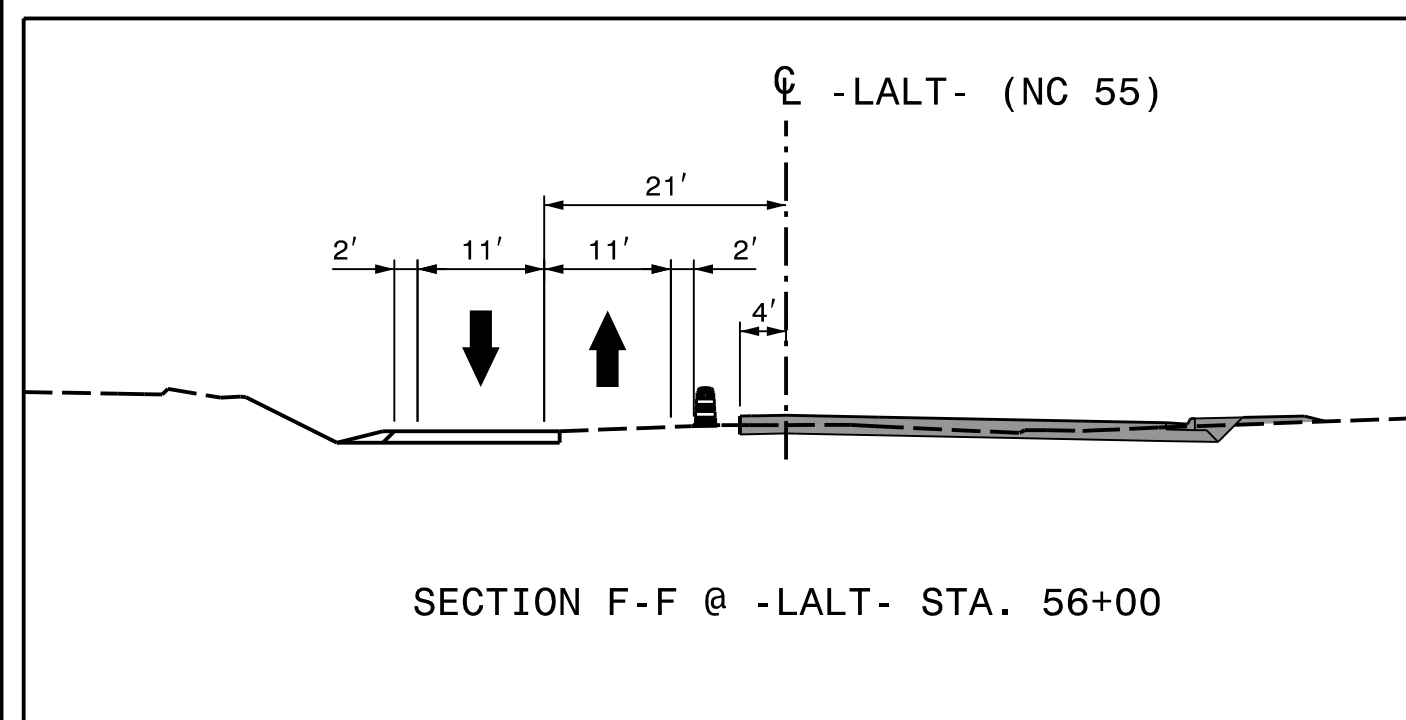
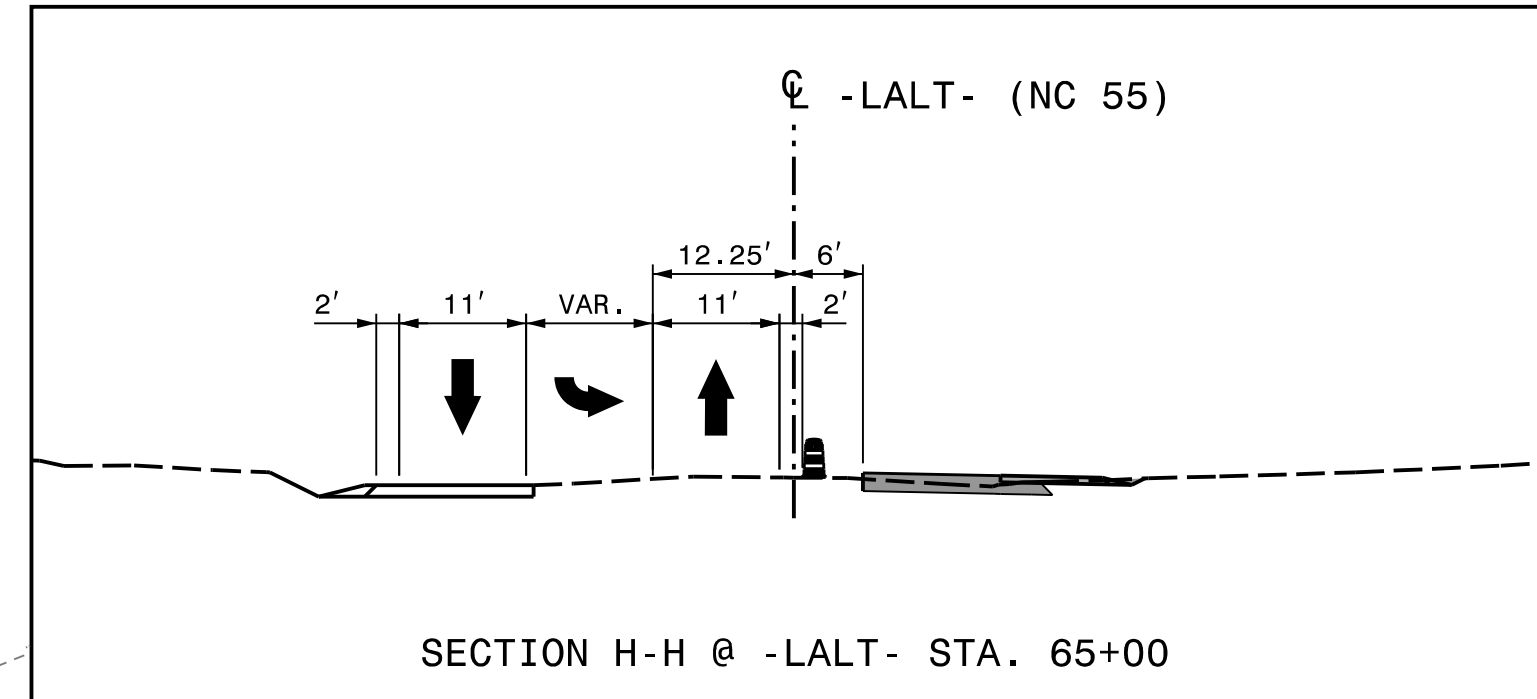

NOTE: ALL LANE WIDTHS ARE 11' UNLESS OTHERWISE SHOWN.

DOCUMENT NOT CONSIDERED FINAL UNLESS ALL SIGNATURES COMPLETED

APPROVED:  DATE: 5/13/2016

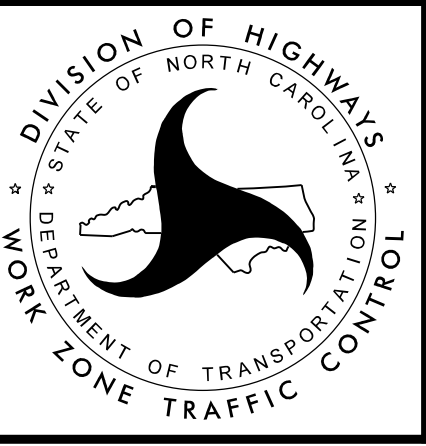

PHASE 1
 STEPS 11 - 20

PLOT DRIVER: NCDOT_color_eng_50.plt
 USER: erbrooks
 DATE: 5/12/2016
 TIME: 4:00:47 PM
 FILE: c:\pwworking\paw\0487729\U-3308_TMP-12.dgn

REVISIONS

MATCHLINE -LALT- STA. 53+50, SEE SHEET TMP-11

- NOTES:
1. USING A LANE CLOSURE ALONG NC 55, REMOVE EXISTING PAVEMENT AND PLACE TEMPORARY PAVEMENT TO TIE FROM EXISTING TO PERMANENT ELEVATION ACROSS INTERSECTION FROM -LALT- STA. 48+25 +/- TO STA. 49+50 +/- (4' LT-9' LT)
 2. PLACE VARIABLE DEPTH WEDGING OVER PROPOSED PAVEMENT FROM THE EDGE OF TEMPORARY PAVEMENT (4' LT) TO THE PROPOSED -LALT- CENTERLINE. PLACE WEDGING TO CREATE A SMOOTH TRANSITION FROM PROPOSED TO EXIST PAVEMENT AND TO CREATE POSITIVE DRAINAGE WITHIN THE INTERSECTION.
 3. MAINTAIN "NO LEFT TURN" SIGNING AS PREVIOUSLY INSTALLED (SHEET TMP-11).

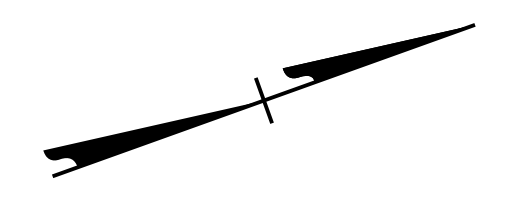

REVISIONS

PLOT DRIVER: NCDOT_pdf_color_eng_50.plt
 USER: erbrooks
 DATE: 5/12/2016
 TIME: 4:00:59 PM
 FILE: c:\pwworking\tpa\d048729\U-3308\TMP-TMP-13.dgn

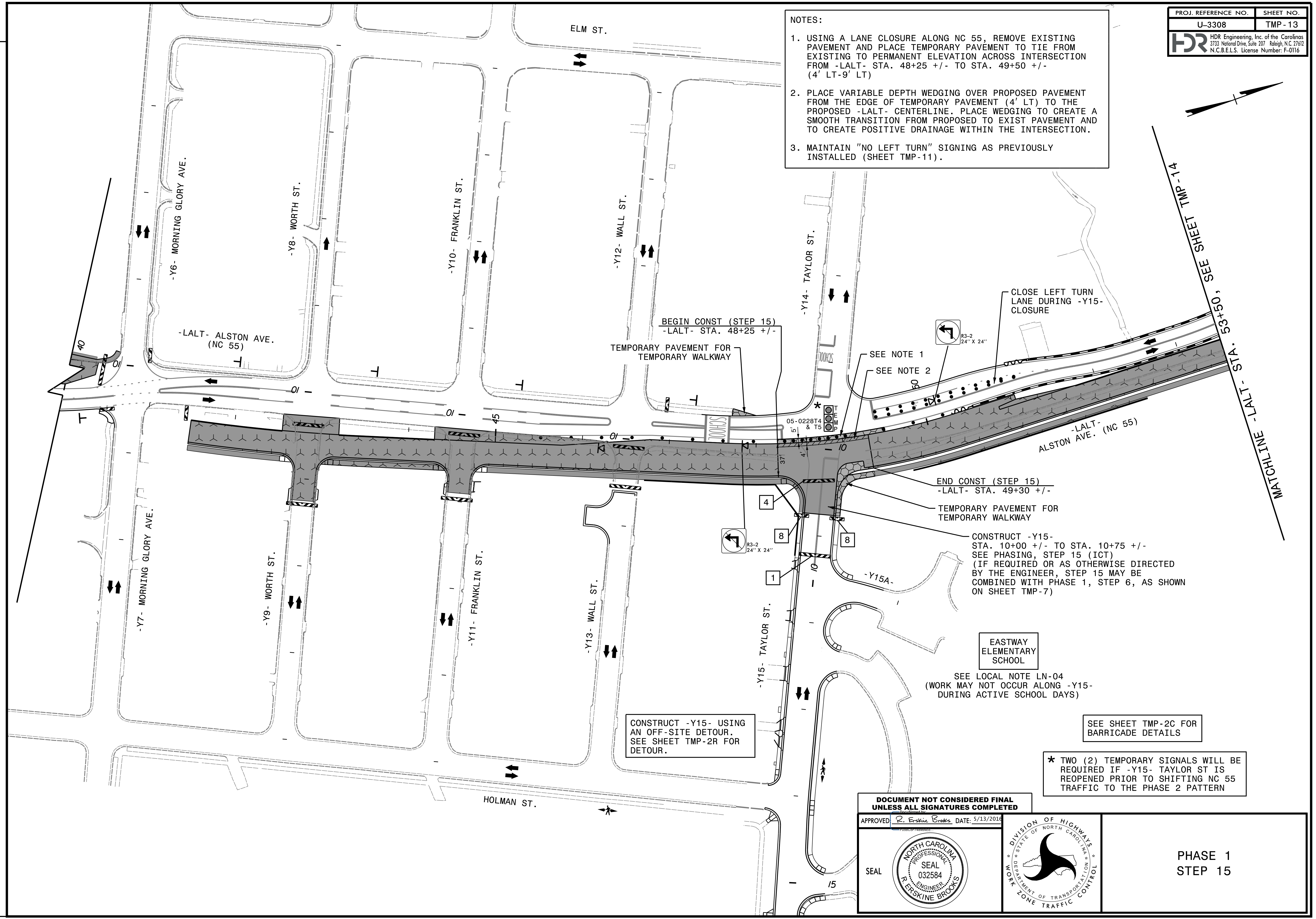

DOCUMENT NOT CONSIDERED FINAL
 UNLESS ALL SIGNATURES COMPLETED

APPROVED:  DATE: 5/13/2016

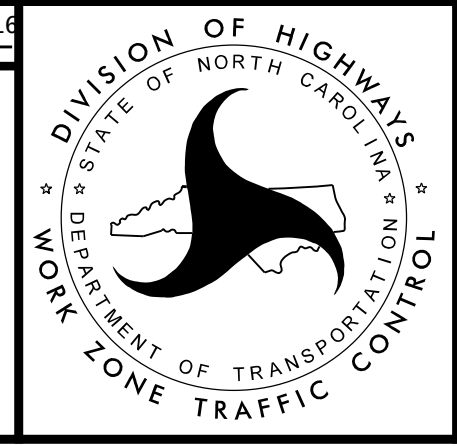

PHASE 1
 STEP 15

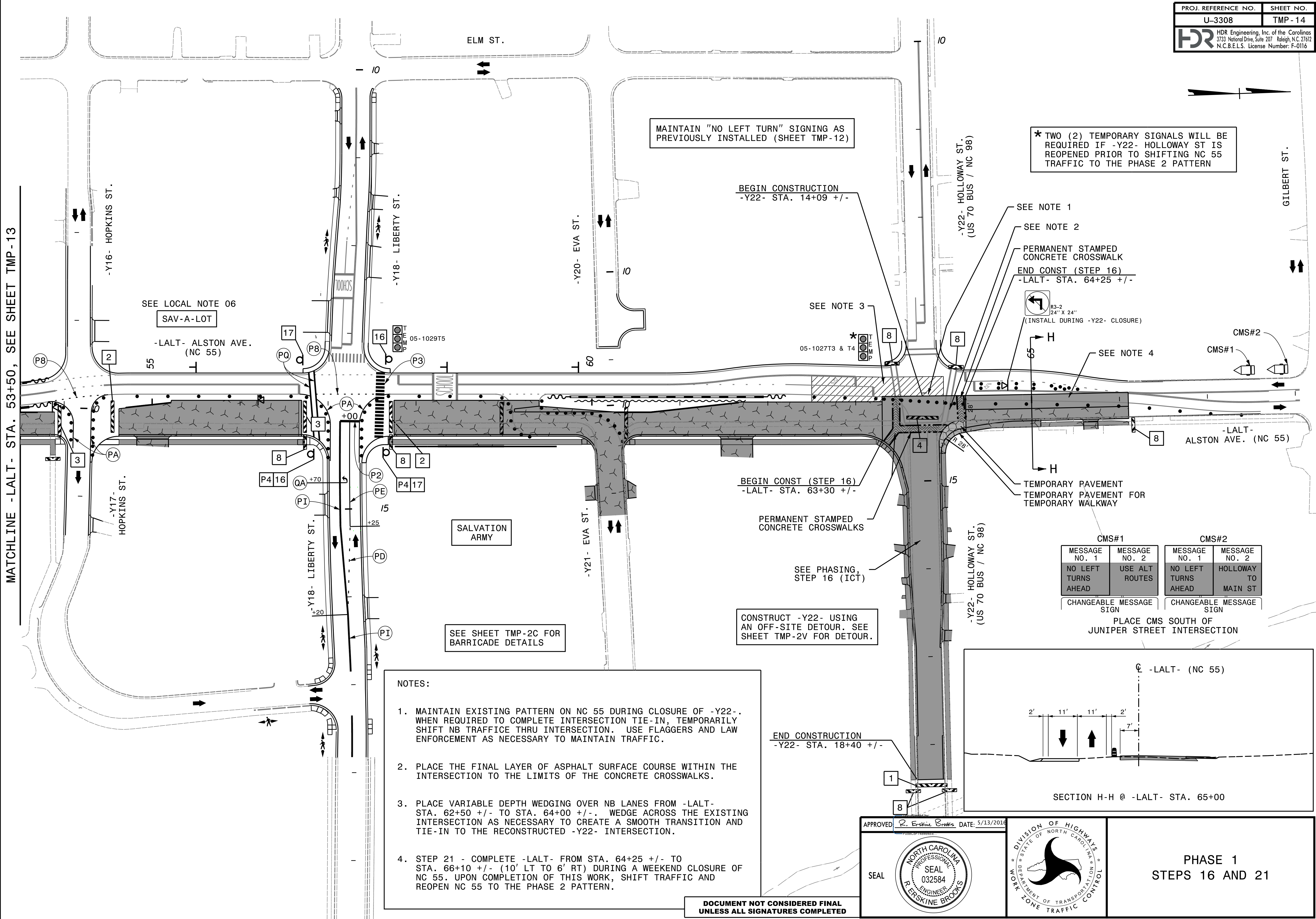

- NOTES:
1. MAINTAIN EXISTING PATTERN ON NC 55 DURING CLOSURE OF -Y22-. WHEN REQUIRED TO COMPLETE INTERSECTION TIE-IN, TEMPORARILY SHIFT NB TRAFFIC THRU INTERSECTION. USE FLAGGERS AND LAW ENFORCEMENT AS NECESSARY TO MAINTAIN TRAFFIC.
 2. PLACE THE FINAL LAYER OF ASPHALT SURFACE COURSE WITHIN THE INTERSECTION TO THE LIMITS OF THE CONCRETE CROSSWALKS.
 3. PLACE VARIABLE DEPTH WEDGING OVER NB LANES FROM -LALT- STA. 62+50 +/- TO STA. 64+00 +/- . WEDGE ACROSS THE EXISTING INTERSECTION AS NECESSARY TO CREATE A SMOOTH TRANSITION AND TIE-IN TO THE RECONSTRUCTED -Y22- INTERSECTION.
 4. STEP 21 - COMPLETE -LALT- FROM STA. 64+25 +/- TO STA. 66+10 +/- (10' LT TO 6' RT) DURING A WEEKEND CLOSURE OF NC 55. UPON COMPLETION OF THIS WORK, SHIFT TRAFFIC AND REOPEN NC 55 TO THE PHASE 2 PATTERN.

CMS#1		CMS#2	
MESSAGE NO. 1	MESSAGE NO. 2	MESSAGE NO. 1	MESSAGE NO. 2
NO LEFT TURNS AHEAD	USE ALT ROUTES	NO LEFT TURNS AHEAD	HOLLOWAY TO MAIN ST
CHANGEABLE MESSAGE SIGN	CHANGEABLE MESSAGE SIGN	CHANGEABLE MESSAGE SIGN	CHANGEABLE MESSAGE SIGN

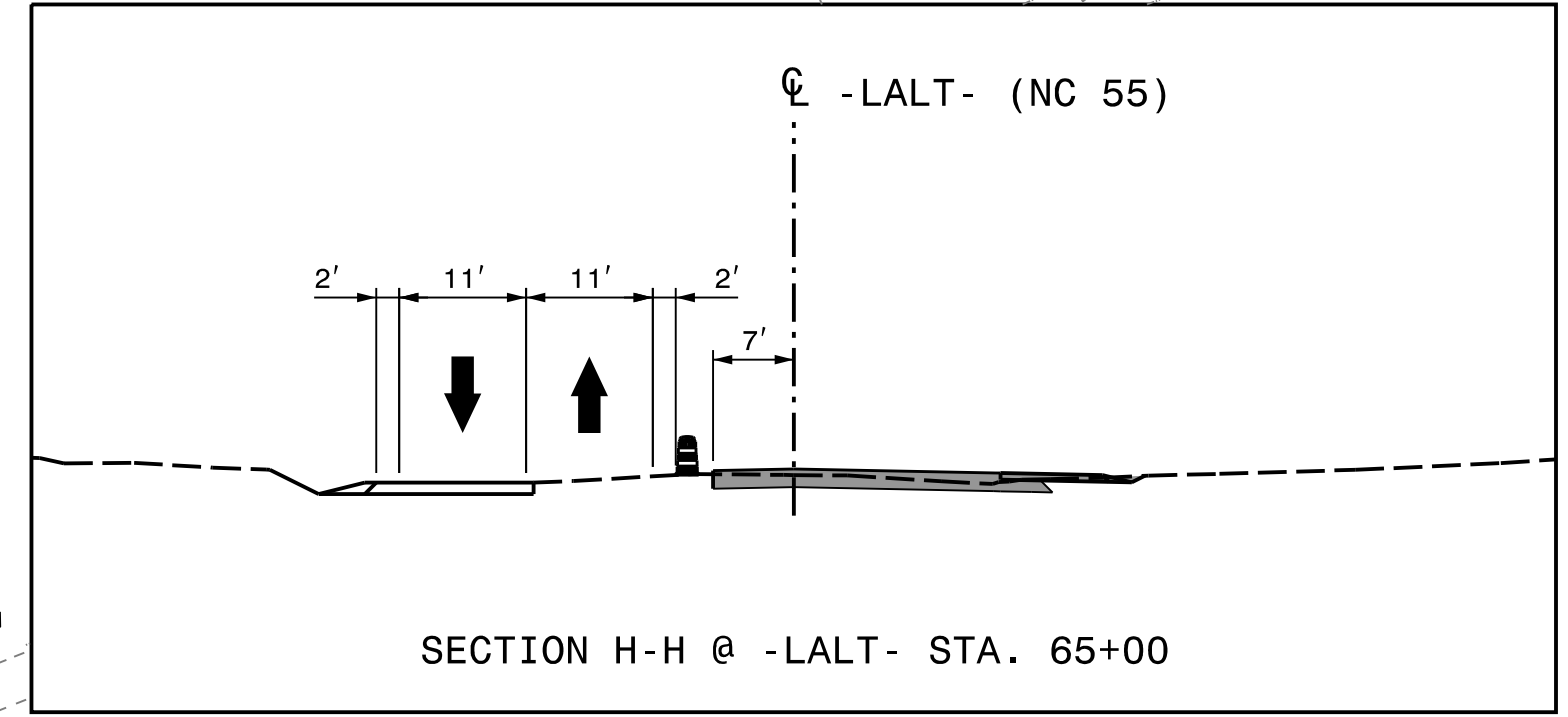

REVISIONS

PLOT DRIVER: NCDOT_pdf_color_eng_50.pit
 USER: erbrooks
 DATE: 5/12/2016
 TIME: 4:01:14 PM
 FILE: c:\pwworking\tpa\d0487729\U-3308_TMP-14.dgn

APPROVED  DATE: 5/13/2016

SEAL

NORTH CAROLINA PROFESSIONAL ENGINEER SEAL 032584 P. ERSKINE BROOKS



PHASE 1
 STEPS 16 AND 21

DOCUMENT NOT CONSIDERED FINAL UNLESS ALL SIGNATURES COMPLETED

SEE SHEET TMP-4, TMP-4A, AND TMP-4B FOR SECTIONS A-A, A1-A1, A2-A2, B-B, & B4-B4

SHORING 1 2 WILL REMAIN IN PLACE AND BE CUT OFF BELOW THE FINAL SURFACE ELEVATION

PROJ. REFERENCE NO.	SHEET NO.
U-3308	TMP-15
 HDR Engineering, Inc. of the Carolinas 3733 National Drive, Suite 207 Raleigh, N.C. 27612 N.C.B.E.L.S. License Number: F-0116	

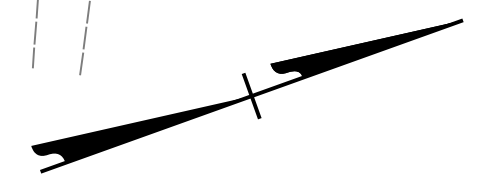

CONSTRUCT -Y- & -Y3A- UNDER TRAFFIC WHILE MAINTAINING -Y- BRIDGE CLOSURE.

CONSTRUCT -Y3A- FROM STA. 10+64 +/- TO STA. 12+87 +/-

-Y3A- CHATHAM PL.

BEGIN CONSTRUCTION -Y- STA. 11+50 +/-

END PORT. CONC. BARRIER TEMP. CRASH CUSHION -LALT- STA. 18+00 +/-

BEGIN PORT. CONC. BARRIER TEMP. CRASH CUSHION -LALT- STA. 14+90 +/-

MILL TEMPORARY WEDGING PLACED DURING PHASE 1, STEP 5 WHEN COMPLETING THE -R5- INTERSECTION TIE-IN

BEGIN PORT. CONC. BARRIER TEMPORARY CRASH CUSHION -LALT- STA. 21+95 +/-

END PORT. CONC. BARRIER TEMPORARY CRASH CUSHION -LALT- STA. 25+45 +/-

-LALT- ALSTON AVE. (NC 55)

COMPLETE WEDGING

BEGIN CONSTRUCTION -LALT- STA. 13+50 +/-

CONSTRUCT -R2-

COMPLETE WIDENING OF -R2- UNDER TRAFFIC OR BY A TEMPORARY CLOSURE AND DETOUR OF RAMP TRAFFIC (SEE SHEET TMP-2G FOR DETOUR ROUTE)

-LALT- STA. 15+00 +/-

BEGIN BRIDGE CONSTRUCTION STAGE 2 -LALT- STA. 15+59 +/-

END BRIDGE CONSTRUCTION STAGE 2 -LALT- STA. 17+39 +/-

END CONST STEP 1 BEGIN CONST STEP 3 -LALT- STA. 20+00 +/-

SEE LOCAL NOTE LN-01 FOR -LALT- (NC 55) BRIDGE CONSTRUCTION OVER -YA- (NC 147)

BEGIN CONST STEP 1 END CONST STEP 3 -LALT- STA. 21+00 +/-

MAINTAIN PEDESTRIAN ACCESS THROUGH WORK AREA

BEGIN BRIDGE CONSTRUCTION -Y- STA. 17+05 +/-

CONSTRUCT -R5- SEE PHASING, STEP 3 (ICT)

END BRIDGE CONSTRUCTION -Y- STA. 17+85 +/-

BEGIN BRIDGE CONSTRUCTION -NSS- STA. 20+21 +/- -NSN- STA. 20+12 +/-

END BRIDGE CONSTRUCTION -NSS- STA. 22+05 +/- -NSN- STA. 21+95 +/-

SEE LOCAL NOTE LN-02 FOR -Y- AND RAIL BRIDGE CONSTRUCTION OVER -LALT- (NC 55)

SEE SHEET TMP-2C FOR BARRICADE DETAILS

INSTALL -R2- DETOUR SIGNS (AS SHOWN ON SHEET TMP-2G) TO DIRECT TRAFFIC FOR PROHIBITED LEFT TURNS FROM NC 55 SB.

*TWO (2) TEMPORARY SIGNALS WILL BE REQUIRED IF -R5- REMAINS OPEN AFTER SHIFTING NC 55 TO THE TEMPORARY PATTERN

NOTE: ALL LANE WIDTHS ARE 11' UNLESS OTHERWISE SHOWN.

DOCUMENT NOT CONSIDERED FINAL UNLESS ALL SIGNATURES COMPLETED

APPROVED:  DATE: 5/13/2016

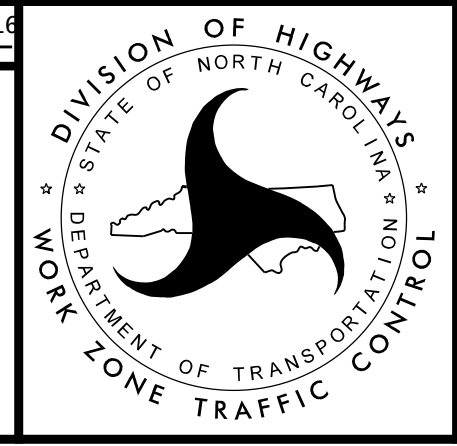
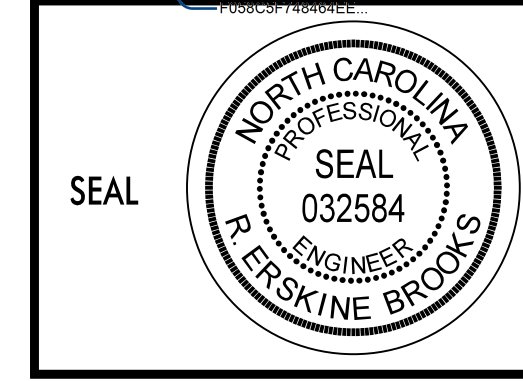

PHASE 2 STEPS 1 - 6

PLOT DRIVER: NCDOT_color_eng_50.plt
USER: erbrooks
DATE: 5/12/2016
TIME: 4:01:27 PM
FILE: c:\pwworking\paw\048729\U-3308\TMP-TMP-15.dgn

REVISIONS

MATCHLINE -LALT- STA. 26+50, SEE SHEET TMP-16

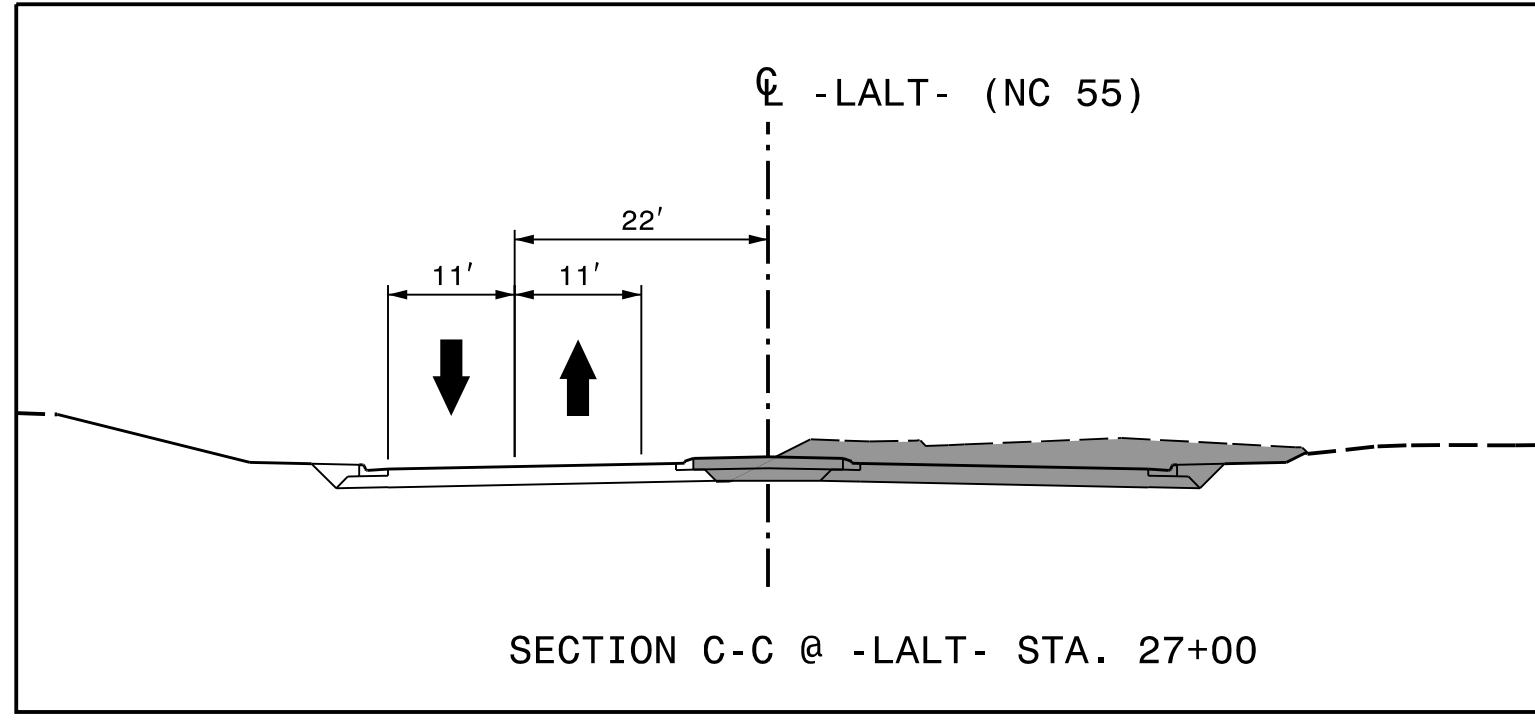
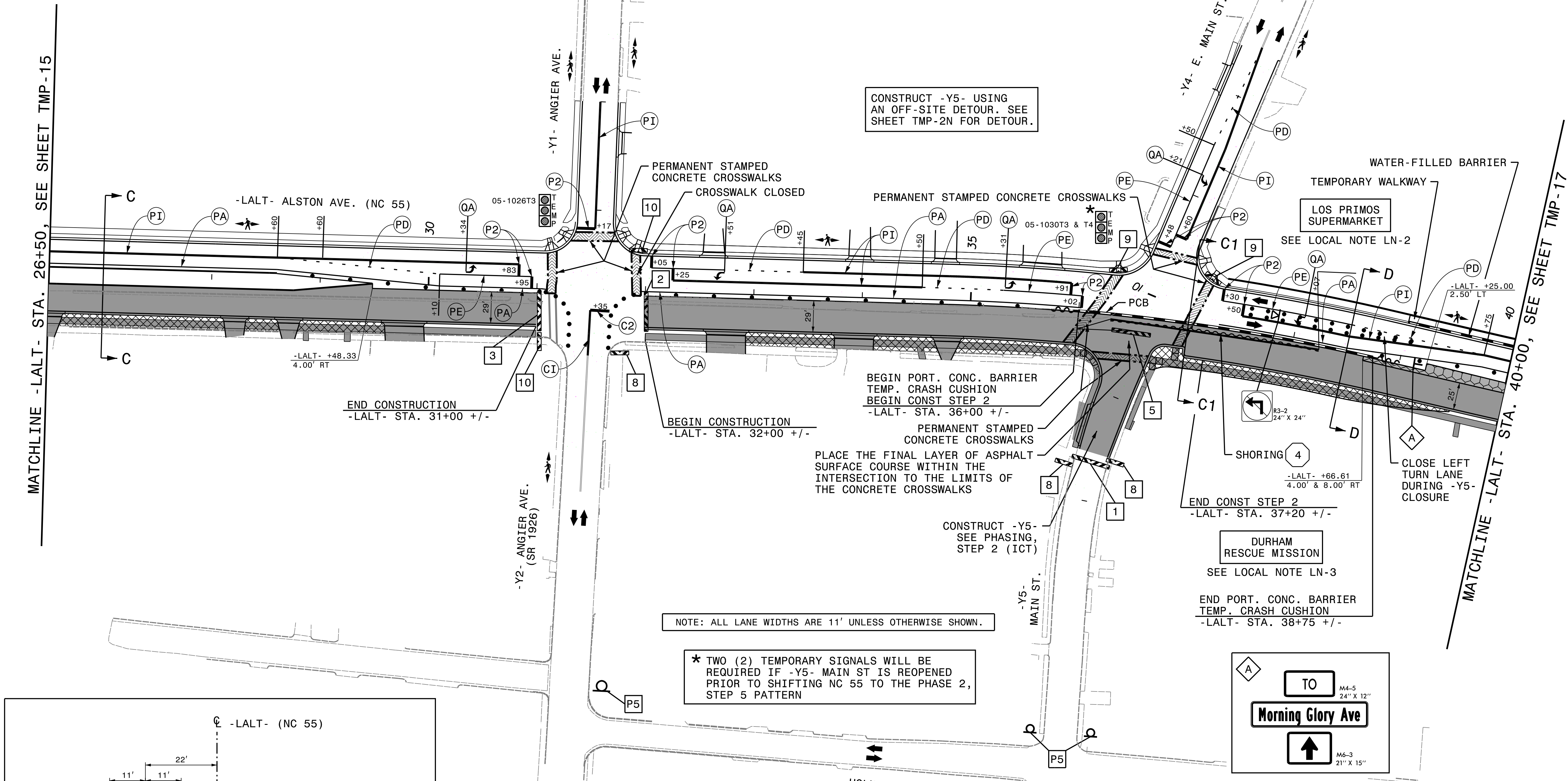
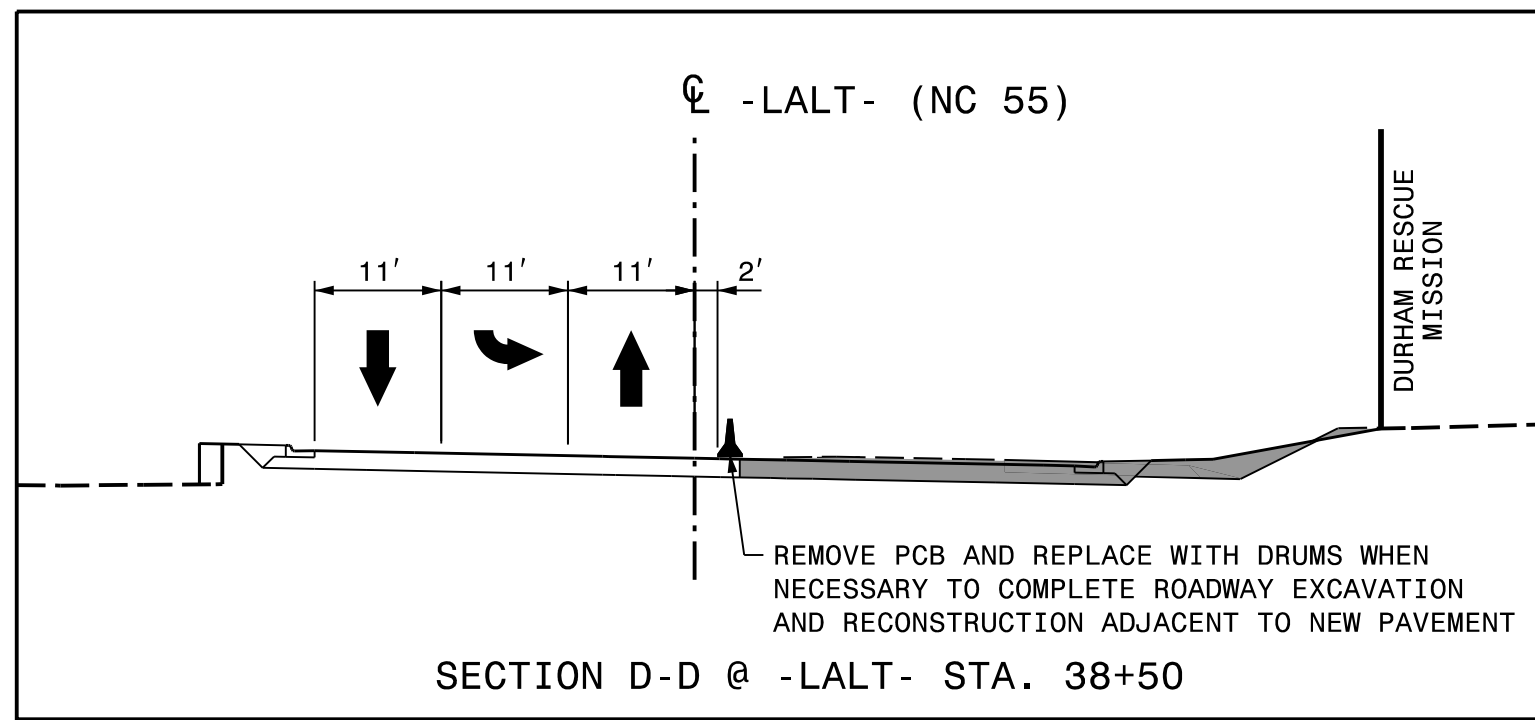
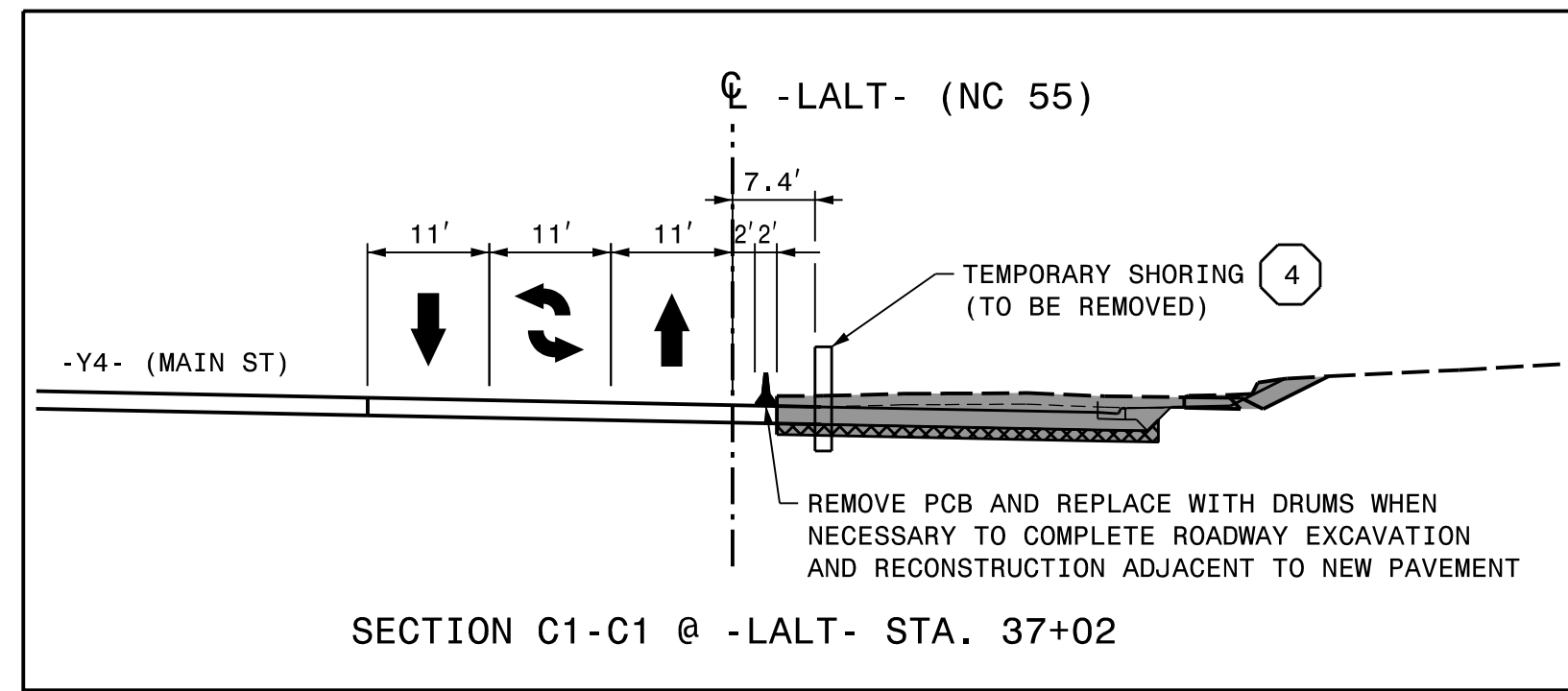

MATCHLINE -LALT- STA. 26+50, SEE SHEET TMP-15

MATCHLINE -LALT- STA. 40+00, SEE SHEET TMP-17

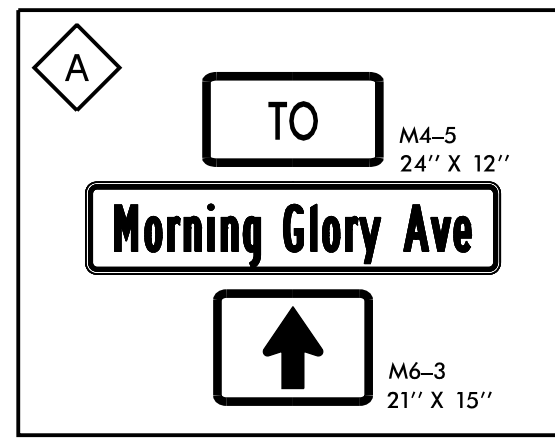



NOTE: ALL LANE WIDTHS ARE 11' UNLESS OTHERWISE SHOWN.

* TWO (2) TEMPORARY SIGNALS WILL BE REQUIRED IF -Y5- MAIN ST IS REOPENED PRIOR TO SHIFTING NC 55 TO THE PHASE 2, STEP 5 PATTERN

SEE SHEET TMP-2C FOR BARRICADE DETAILS

DOCUMENT NOT CONSIDERED FINAL UNLESS ALL SIGNATURES COMPLETED

APPROVED  DATE: 5/13/2016

SEAL

DIVISION OF HIGHWAYS
 STATE OF NORTH CAROLINA
 DEPARTMENT OF TRANSPORTATION
 WORK ZONE TRAFFIC CONTROL

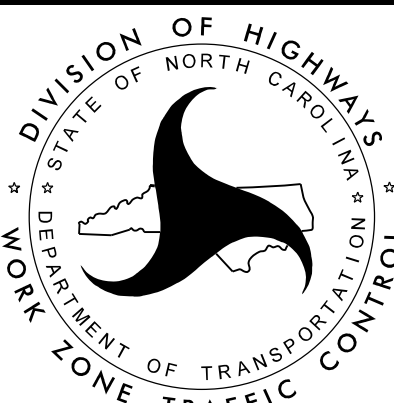

PHASE 2
STEPS 1 - 6

PLOT DRIVER: NCDOT_pdf_color_eng_50.plt
 USER: erbrooks
 DATE: 5/12/2016
 TIME: 4:01:39 PM
 FILE: c:\pwworking\tpa\d048729\U-3308_TMP-TMP-16.dgn

REVISIONS

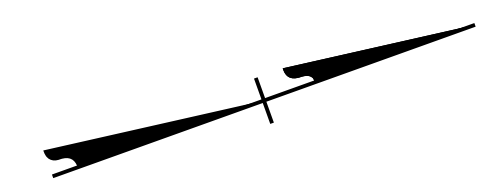

REVISIONS

PLOT DRIVER: NCDOT_pdf_color_eng_50.plt
 USER: erbrooks
 DATE: 5/12/2016
 TIME: 4:01:52 PM
 FILE: c:\pwworking\tpa\d048729\U-3308_TMP-TMP-17.dgn

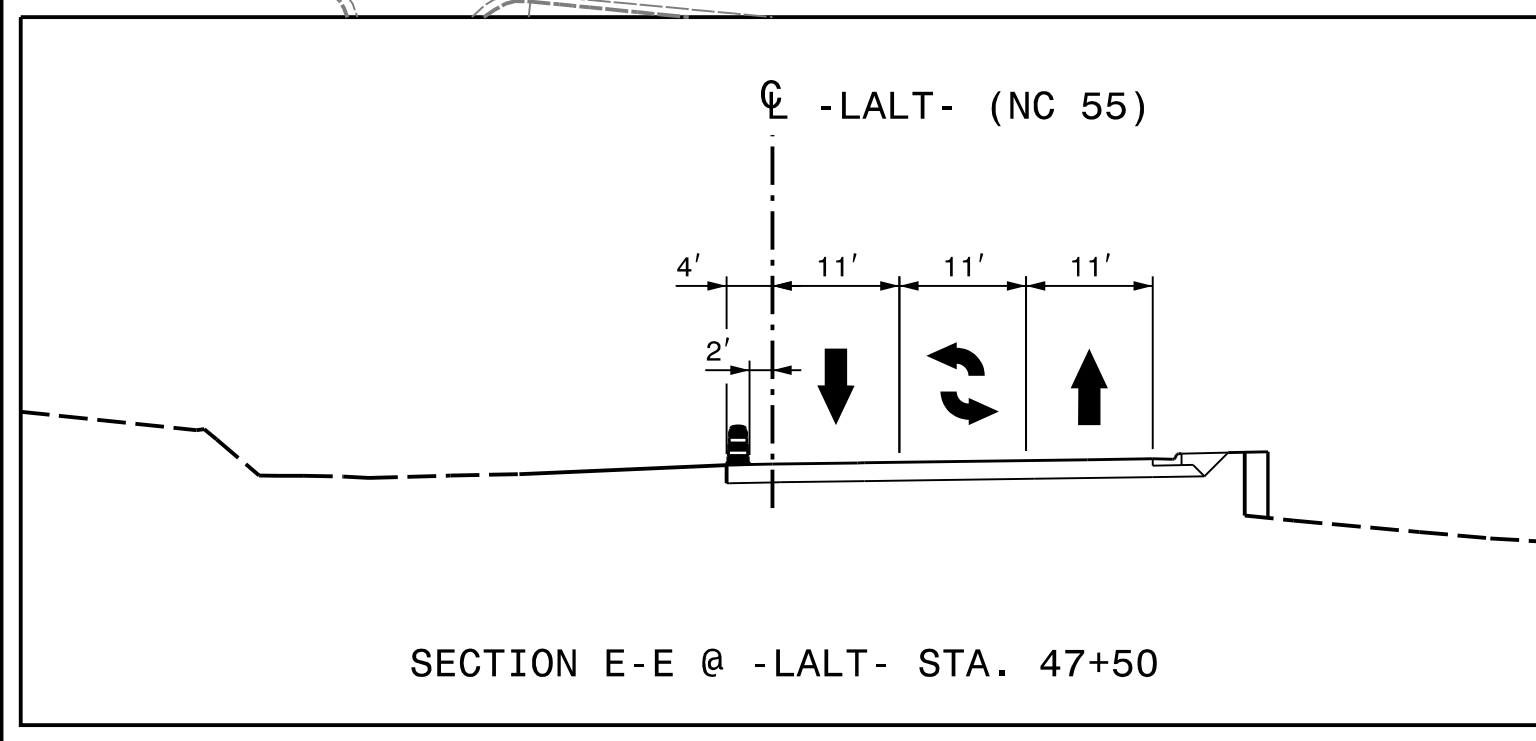
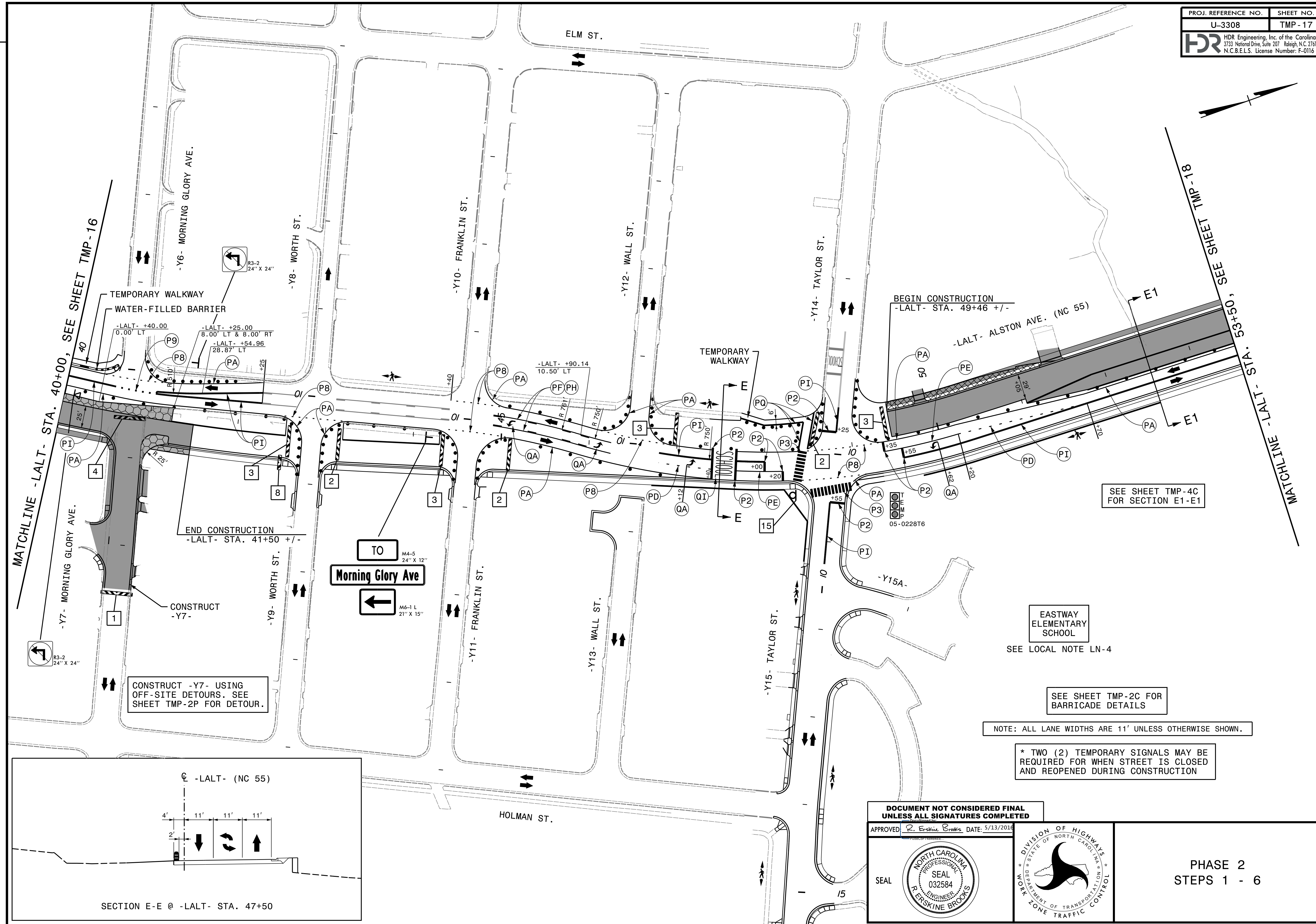

SEE SHEET TMP-4C FOR SECTION E1-E1

EASTWAY ELEMENTARY SCHOOL
SEE LOCAL NOTE LN-4

SEE SHEET TMP-2C FOR BARRICADE DETAILS

NOTE: ALL LANE WIDTHS ARE 11' UNLESS OTHERWISE SHOWN.

* TWO (2) TEMPORARY SIGNALS MAY BE REQUIRED FOR WHEN STREET IS CLOSED AND REOPENED DURING CONSTRUCTION

DOCUMENT NOT CONSIDERED FINAL UNLESS ALL SIGNATURES COMPLETED

APPROVED:  DATE: 5/13/2016

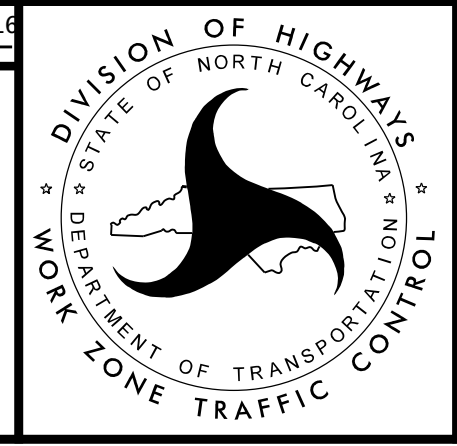

PHASE 2
STEPS 1 - 6

NOTES:

1. INSTALL -Y16-/-Y17- (HOPKINS ST) DETOUR SIGNS (AS SHOWN ON SHEET TMP-2S AND TMP-2T) TO DIRECT TRAFFIC FOR PROHIBITED LEFT TURNS FROM NC 55.
2. INSTALL -Y22- (HOLLOWAY ST) DETOUR SIGNS (AS SHOWN ON SHEET TMP-2W) TO DIRECT TRAFFIC FOR PROHIBITED LEFT TURNS FROM NC 55 SB.

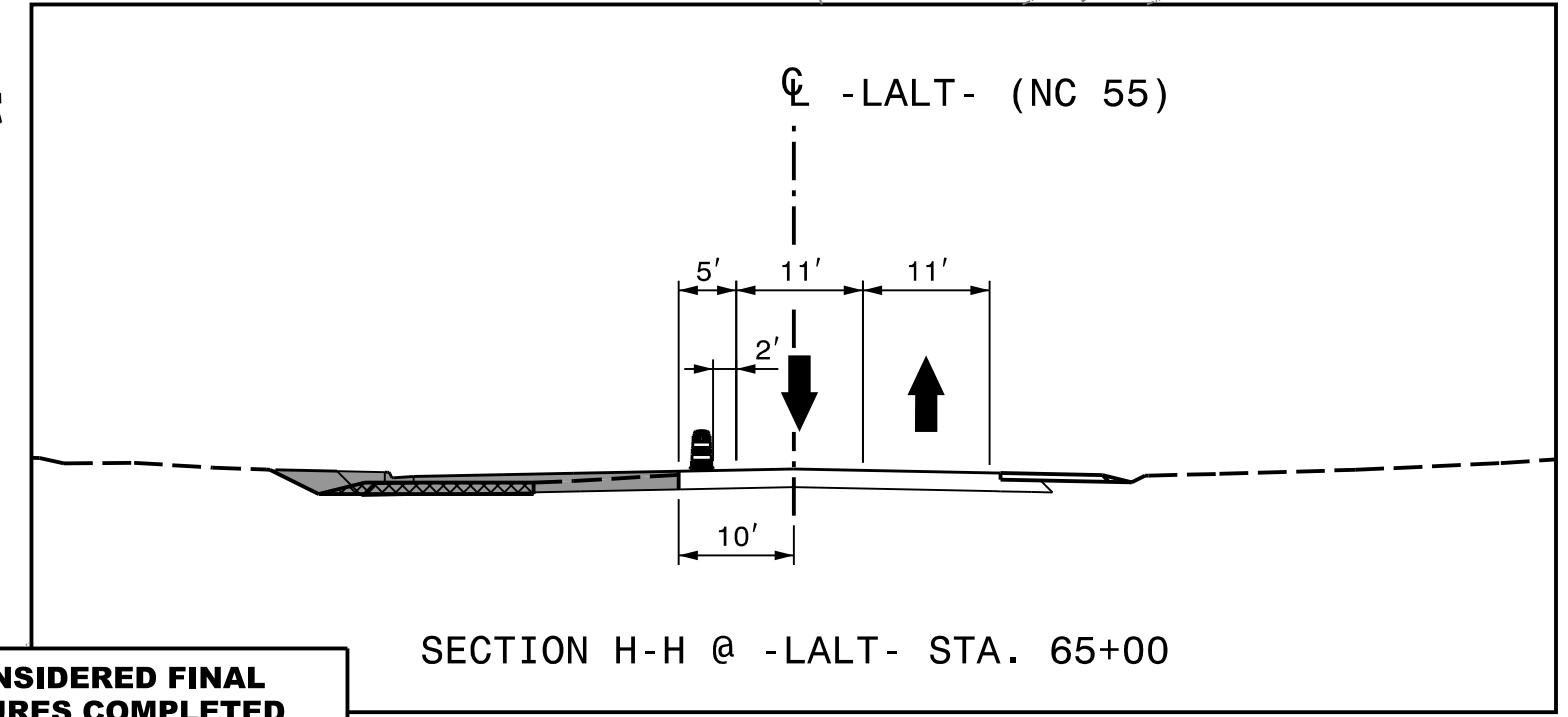
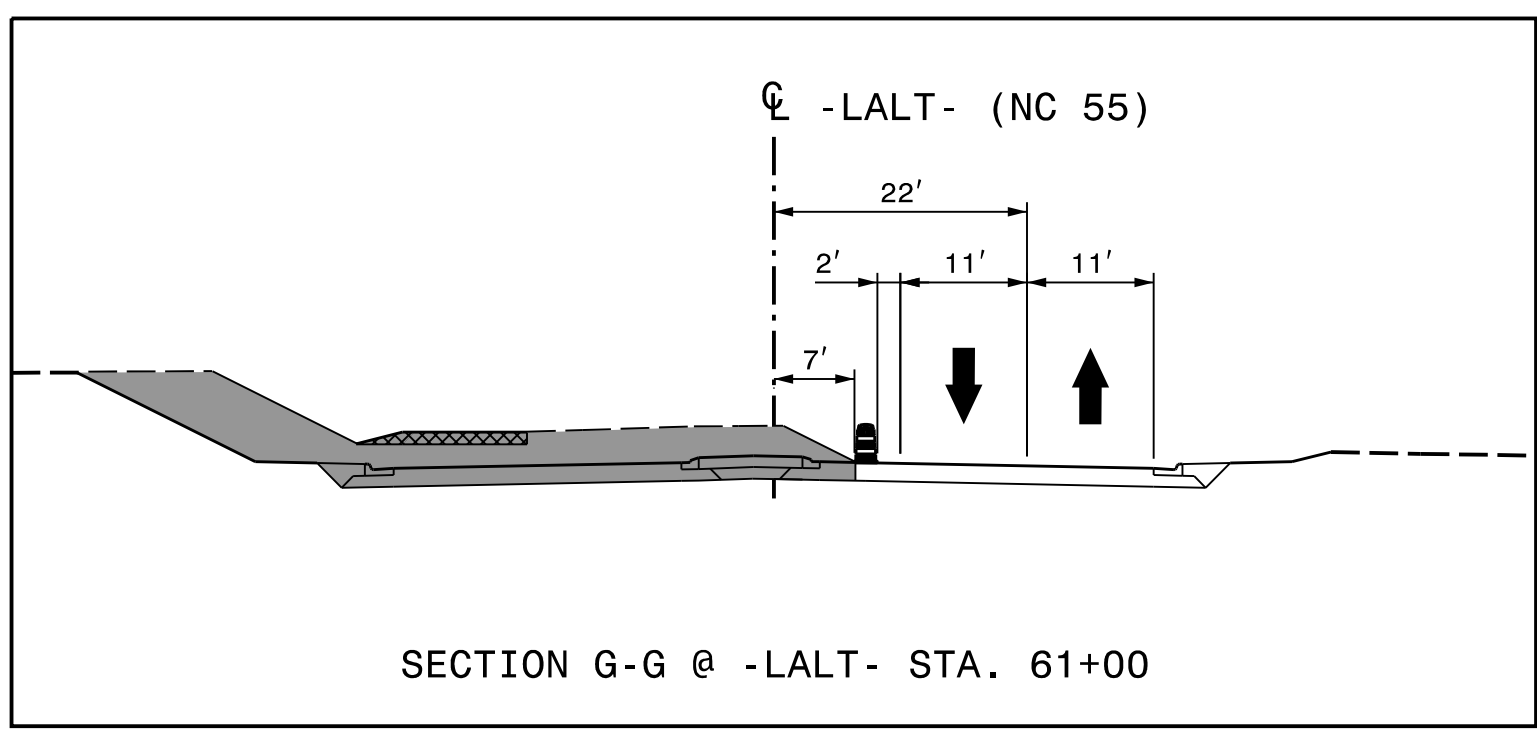
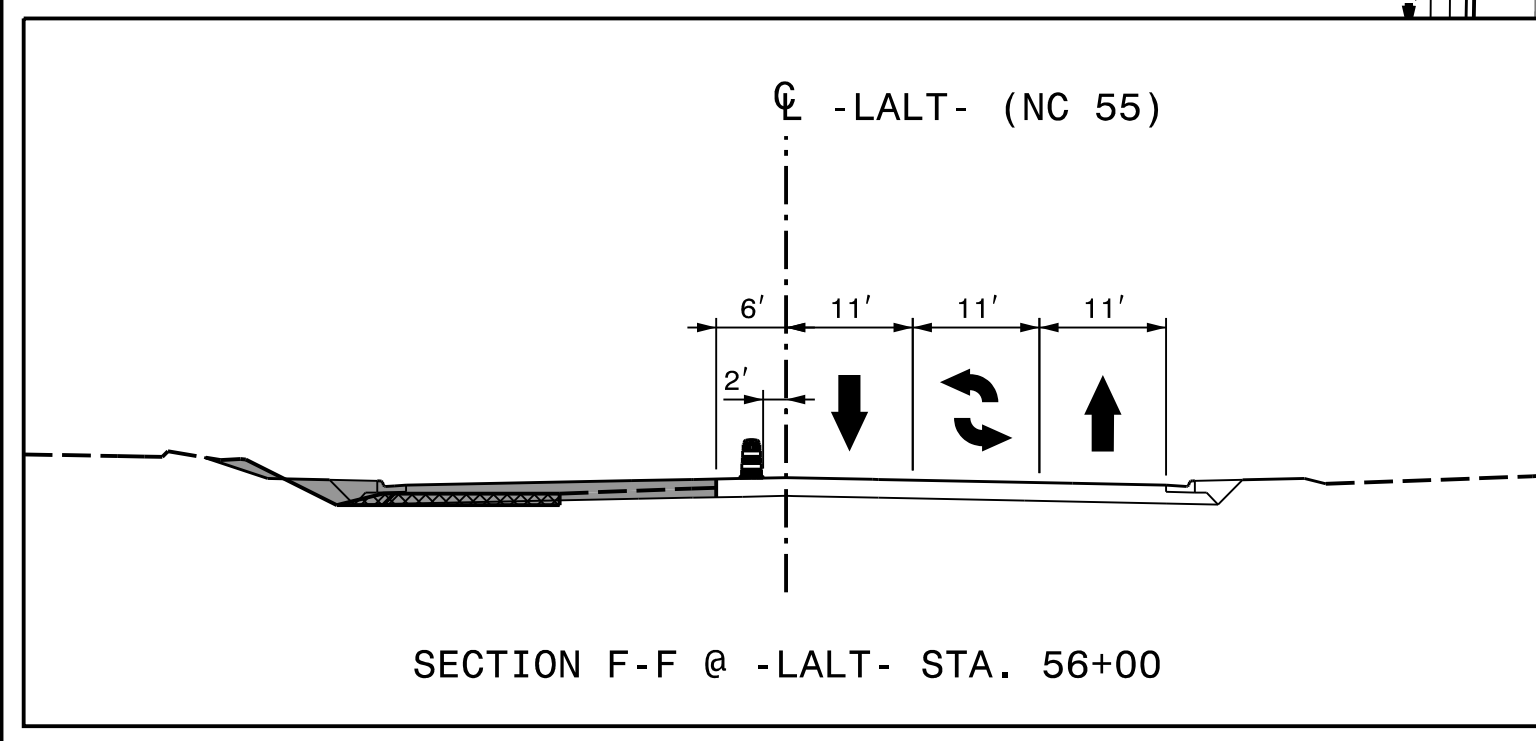
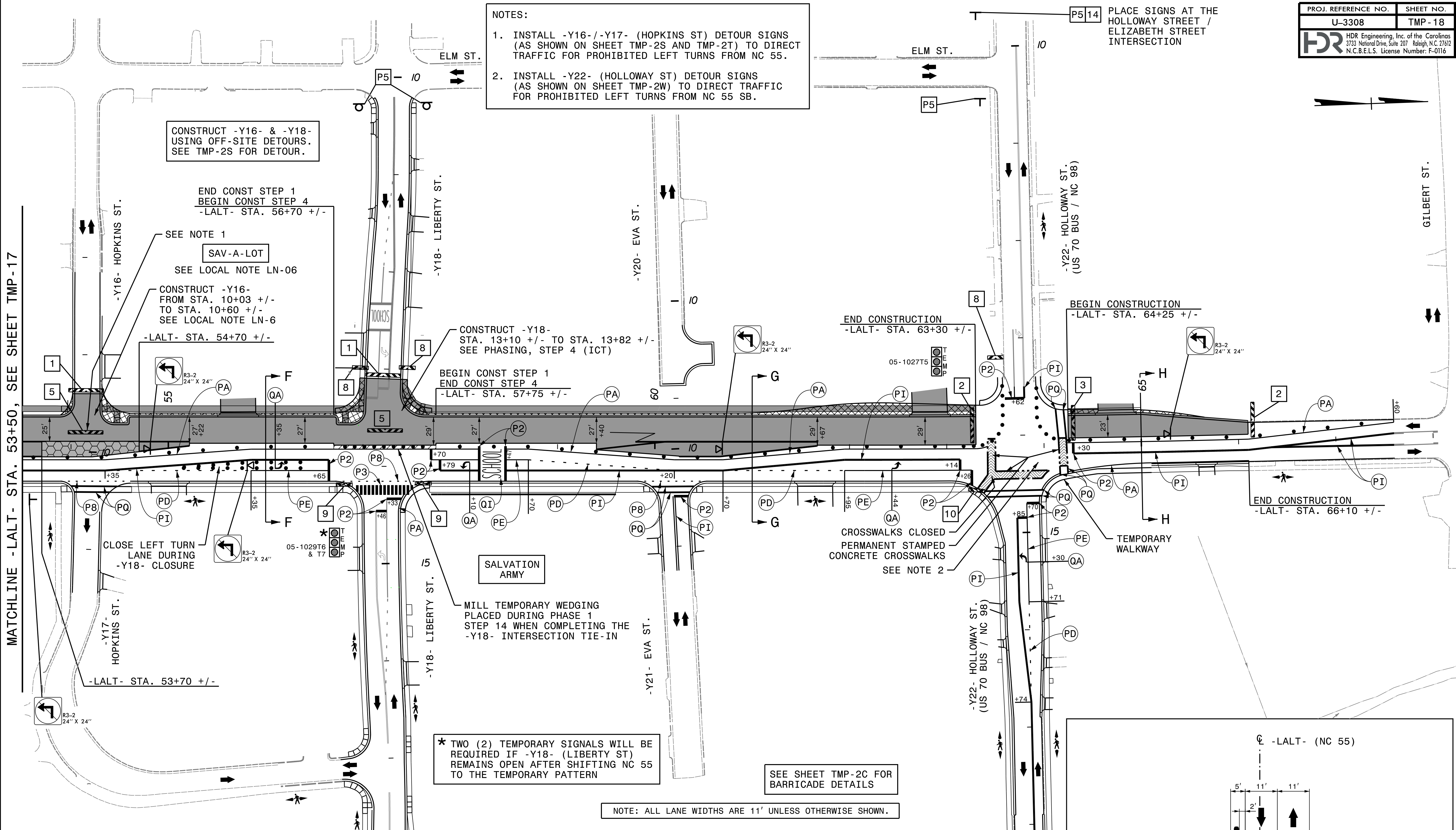

* TWO (2) TEMPORARY SIGNALS WILL BE REQUIRED IF -Y18- (LIBERTY ST) REMAINS OPEN AFTER SHIFTING NC 55 TO THE TEMPORARY PATTERN

SEE SHEET TMP-2C FOR BARRICADE DETAILS

NOTE: ALL LANE WIDTHS ARE 11' UNLESS OTHERWISE SHOWN.

CONSTRUCT -Y16- & -Y18- USING OFF-SITE DETOURS. SEE TMP-2S FOR DETOUR.

END CONST STEP 1
BEGIN CONST STEP 4
-LALT- STA. 56+70 +/-

CONSTRUCT -Y16- FROM STA. 10+03 +/- TO STA. 10+60 +/- SEE LOCAL NOTE LN-6

CONSTRUCT -Y18- STA. 13+10 +/- TO STA. 13+82 +/- SEE PHASING, STEP 4 (ICT)

END CONSTRUCTION
-LALT- STA. 63+30 +/-

BEGIN CONSTRUCTION
-LALT- STA. 64+25 +/-

END CONSTRUCTION
-LALT- STA. 66+10 +/-

MATCHLINE -LALT- STA. 53+50, SEE SHEET TMP-17

REVISIONS

PLOT DRIVER: NCDOT_pdf_color_eng_50.plt
 USER: erbrooks
 FILE: c:\pwworking\tpa\d0487729\U-3308_TMP-TMP-18.dgn
 PENTABLE: NCDOT_tcp.tbl
 DATE: 5/12/2016
 TIME: 4:02:03 PM

DOCUMENT NOT CONSIDERED FINAL UNLESS ALL SIGNATURES COMPLETED

APPROVED:  DATE: 5/13/2016

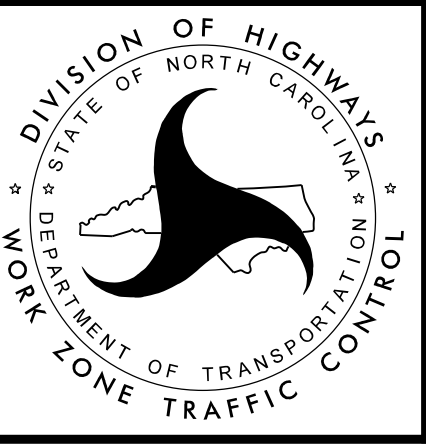

PHASE 2
STEPS 1 - 6

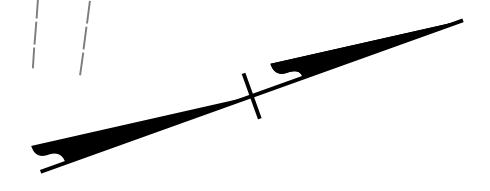

PLACE TEMPORARY MARKINGS IN THE FINAL PATTERN ON -Y3A- & -Y-

MAINTAIN "NO LEFT TURN" SIGNING AS PREVIOUSLY INSTALLED

STEP 8: COMPLETE CLOSURE POUR (USE A ONE-LANE FLAGGER OPERATION FROM 8:00 PM TO 6:00 AM)

REMOVE TEMPORARY SPAN AND COMPLETE -CSX- BRIDGE (STEP 12)

SEE LOCAL NOTE LN-02 FOR RAIL BRIDGE CONSTRUCTION OVER -LALT- (NC 55)

PLACE ALL RAIL TRAFFIC ON -NSN- / -NSS- TRACKS (STEP 12)

SEE SHEET TMP-2C FOR BARRICADE DETAILS

MATCHLINE -LALT- STA. 26+50, SEE SHEET TMP-20

REVISIONS

PLOT DRIVER: NCDOT_pdf_color_eng_50.plt PENTABLE: NCDOT_tcp.tbl
USER: erbrooks DATE: 5/12/2016 TIME: 4:02:14 PM
FILE: c:\pwworking\tpa\d048729\U-3308_TMP-19.dgn

DOCUMENT NOT CONSIDERED FINAL UNLESS ALL SIGNATURES COMPLETED

APPROVED  DATE: 5/13/2016

SEAL

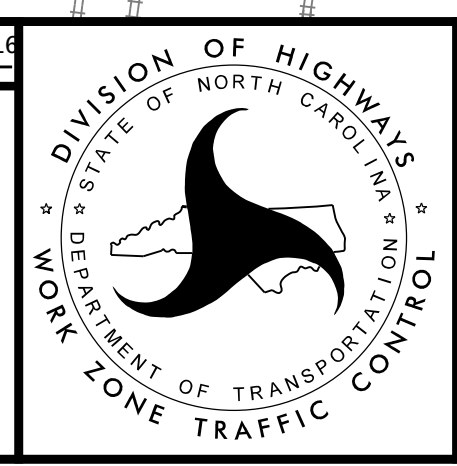

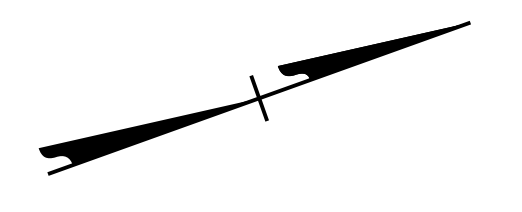
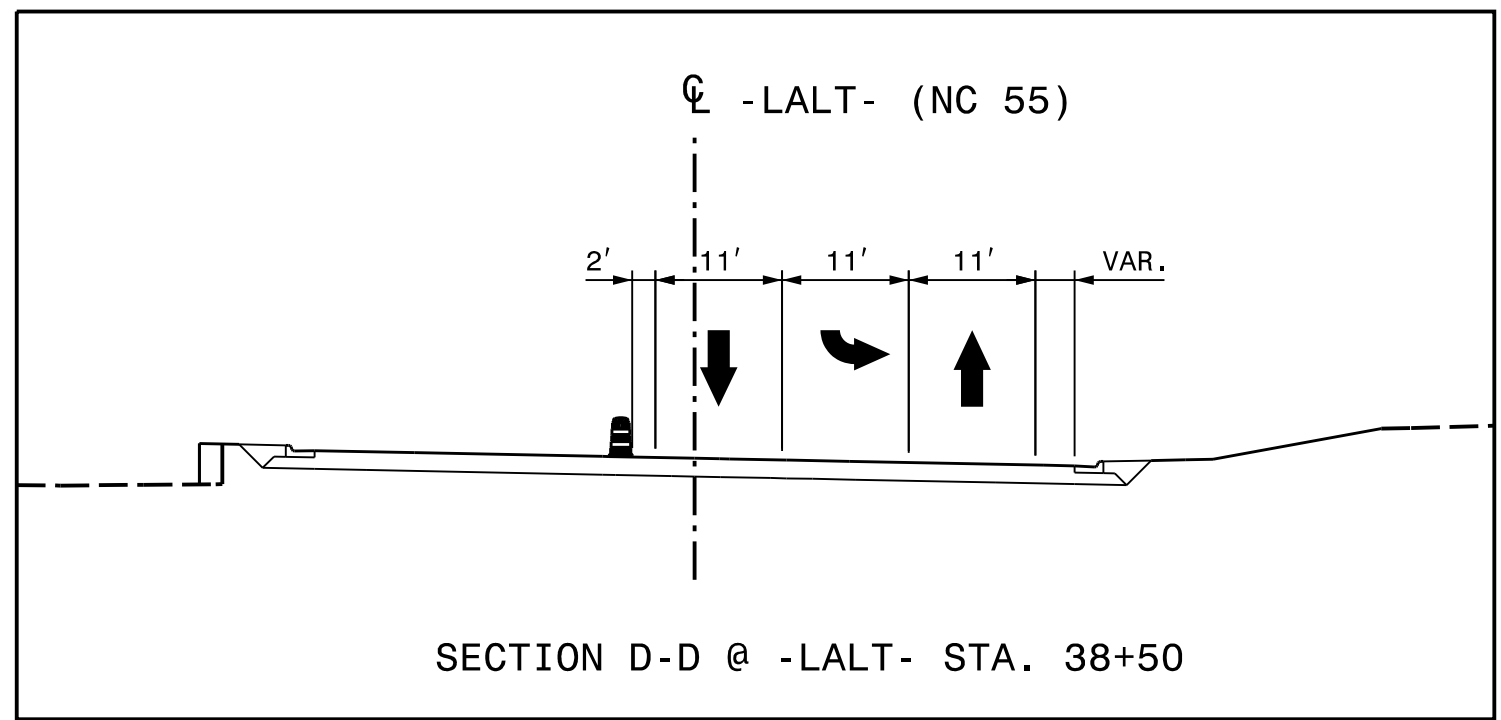

PHASE 2
STEPS 7 - 11

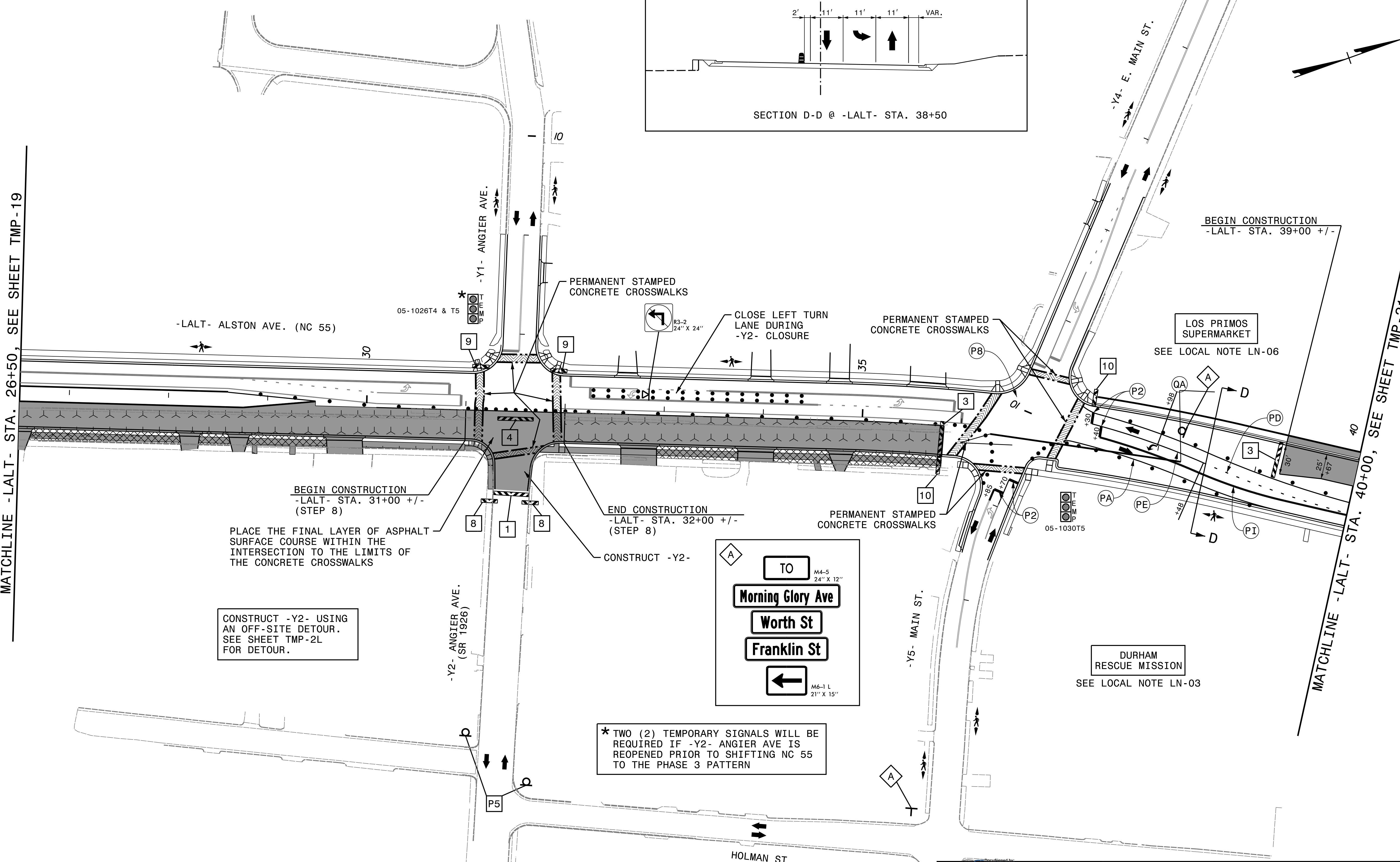

MATCHLINE -LALT- STA. 26+50, SEE SHEET TMP-19

MATCHLINE -LALT- STA. 40+00, SEE SHEET TMP-21



BEGIN CONSTRUCTION
-LALT- STA. 31+00 +/-
(STEP 8)

PLACE THE FINAL LAYER OF ASPHALT
SURFACE COURSE WITHIN THE
INTERSECTION TO THE LIMITS OF
THE CONCRETE CROSSWALKS

CONSTRUCT -Y2- USING
AN OFF-SITE DETOUR.
SEE SHEET TMP-2L
FOR DETOUR.

END CONSTRUCTION
-LALT- STA. 32+00 +/-
(STEP 8)

CONSTRUCT -Y2-

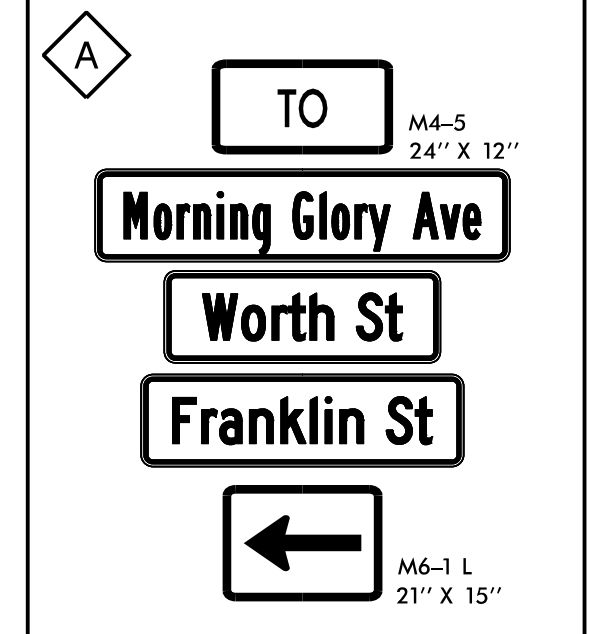

* TWO (2) TEMPORARY SIGNALS WILL BE
REQUIRED IF -Y2- ANGIER AVE IS
REOPENED PRIOR TO SHIFTING NC 55
TO THE PHASE 3 PATTERN

SEE SHEET TMP-2C FOR
BARRICADE DETAILS

NOTE: ALL LANE WIDTHS ARE 11' UNLESS OTHERWISE SHOWN.

DOCUMENT NOT CONSIDERED FINAL
UNLESS ALL SIGNATURES COMPLETED

REVISIONS

PLOT DRIVER: NCDOT_pdf_color_eng_50.plt
 USER: erbrooks
 DATE: 5/12/2016
 TIME: 4:02:25 PM
 FILE: c:\pwworking\tpa\d048729\U-3308_TMP-TMP-20.dgn

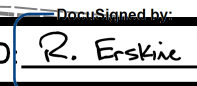
APPROVED  DATE: 5/13/2016

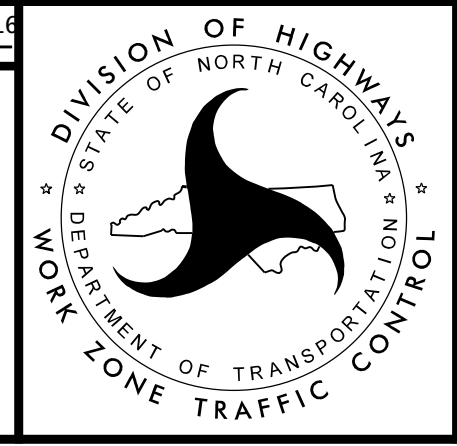
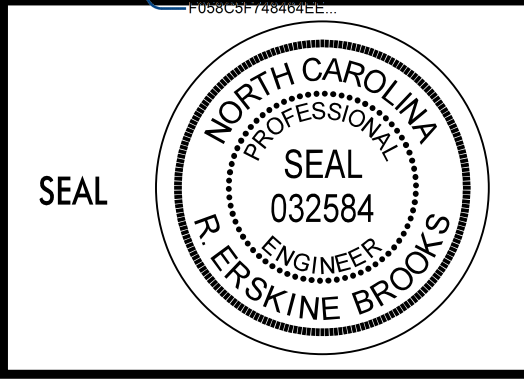

PHASE 2
STEPS 7 - 11

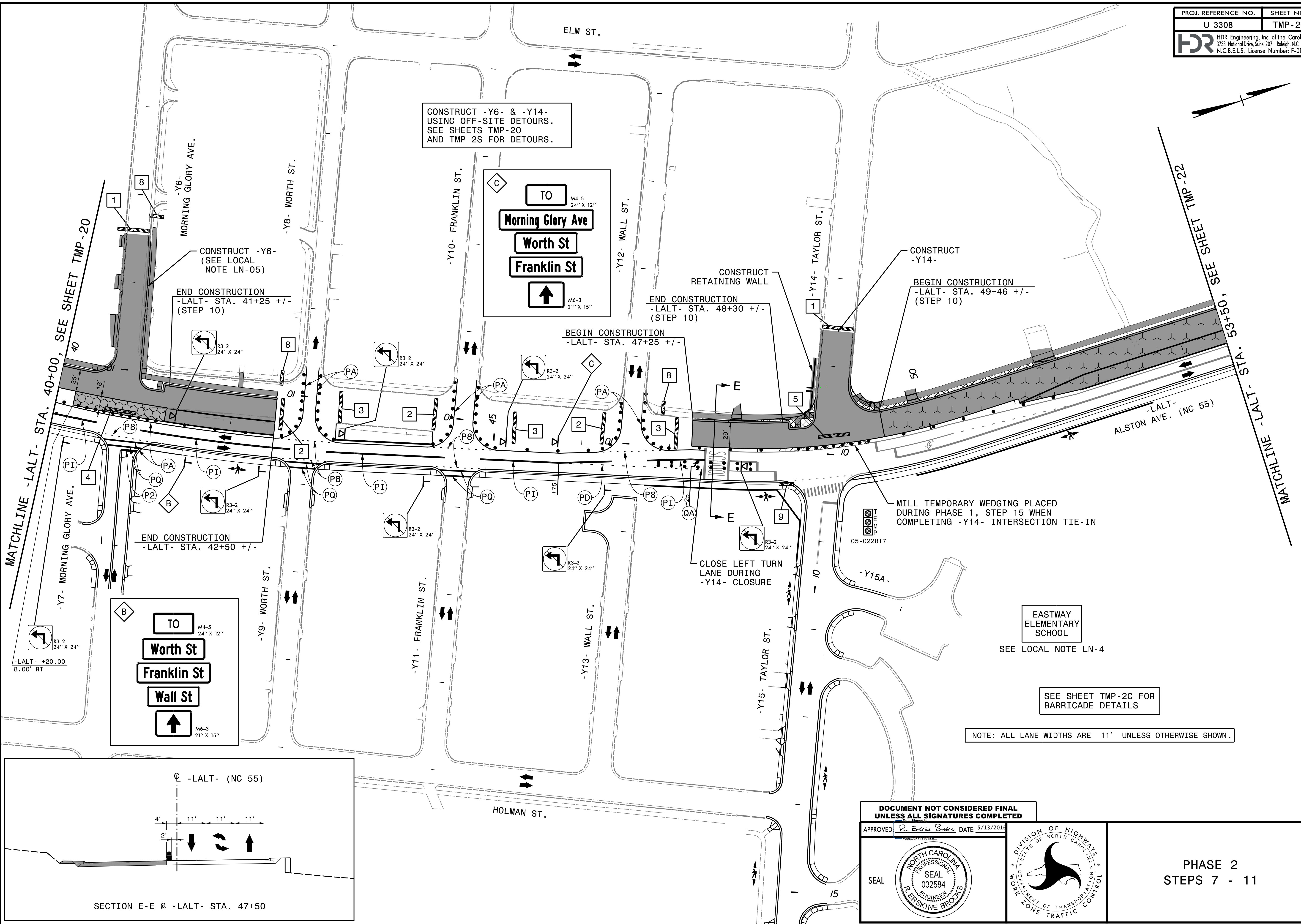
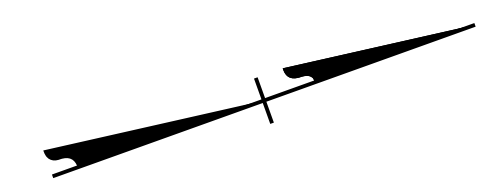

REVISIONS

PLOT DRIVER: NCDOT_pdf_color_eng_50.plt
 USER: erbrooks
 FILE: c:\pwworking\tpa\d0487729\U-3308_TMP-TMP-21.dgn
 PENTABLE: NCDOT_tcp.tbl
 DATE: 5/12/2016
 TIME: 4:02:37 PM

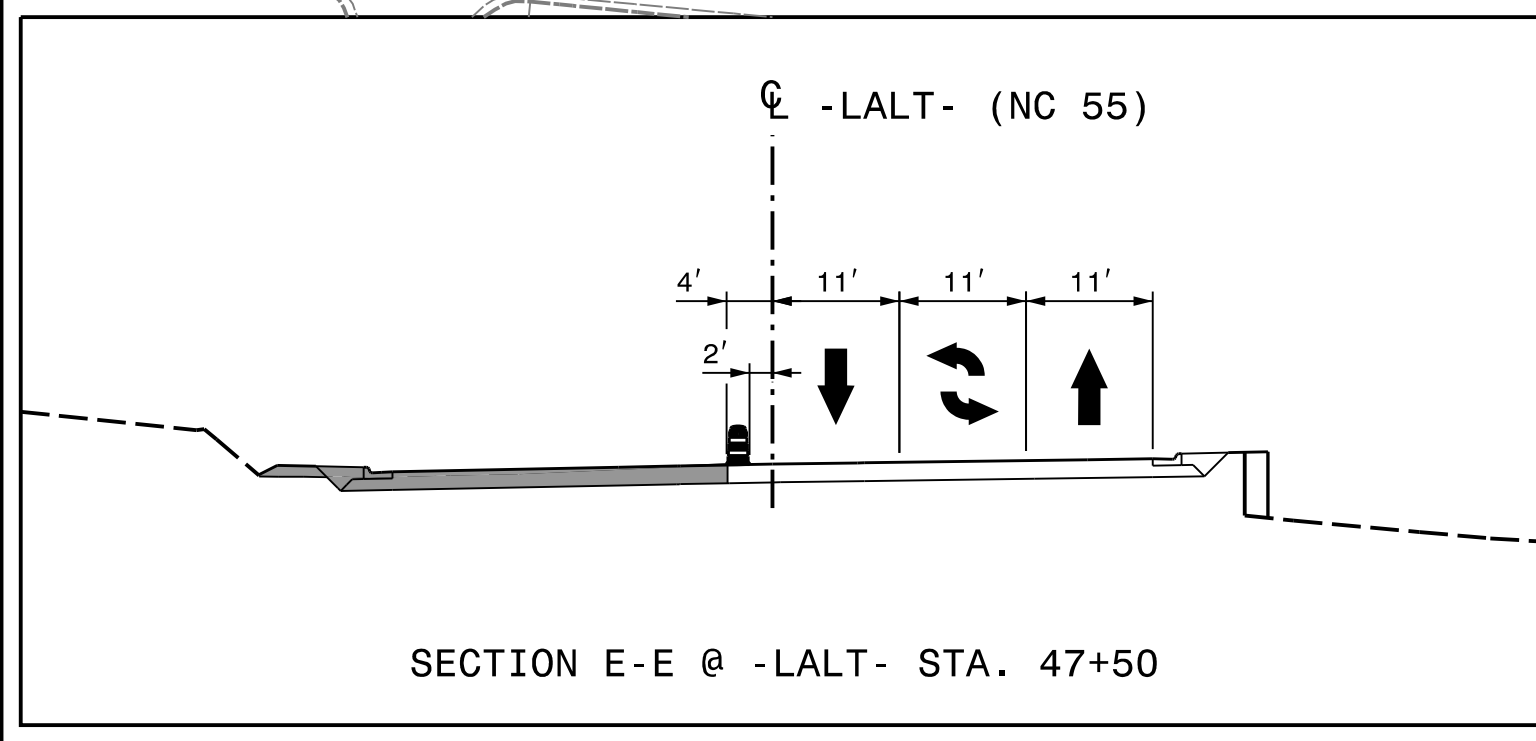

**DOCUMENT NOT CONSIDERED FINAL
 UNLESS ALL SIGNATURES COMPLETED**

APPROVED  DATE: 5/13/2016

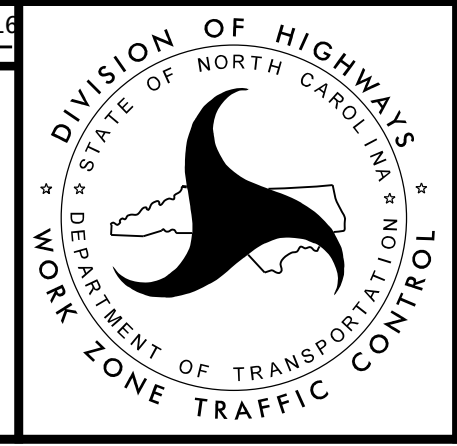

**PHASE 2
 STEPS 7 - 11**

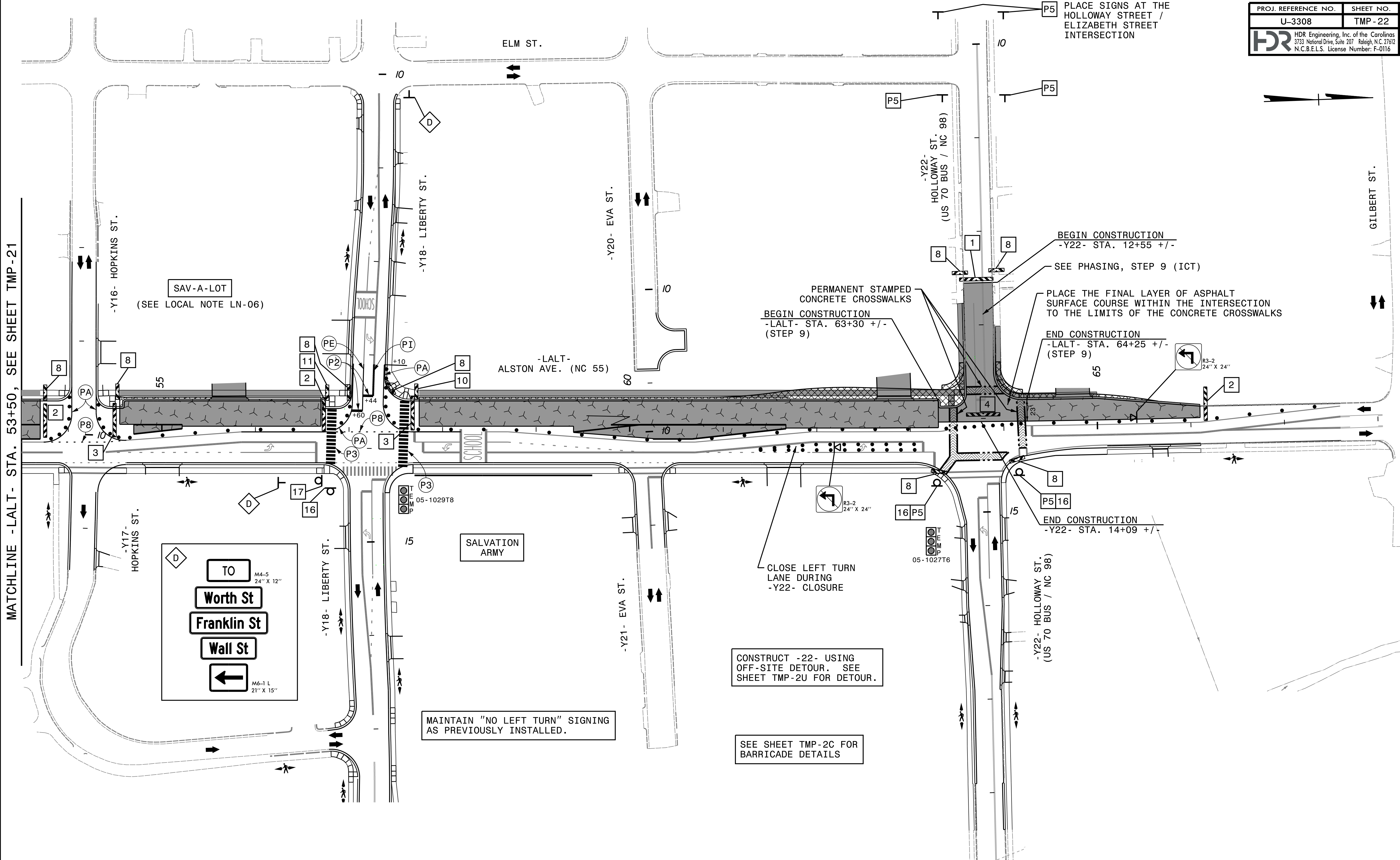
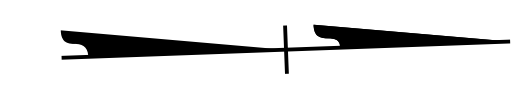

REVISIONS

PLOT DRIVER: NCDOT_pdf_color_eng_50.plt
 USER: erbrooks
 FILE: c:\pwworking\tpa\d0487729\U-3308_TMP-TMP-22.dgn
 PENTABLE: NCDOT_tcp.tbl
 DATE: 5/12/2016
 TIME: 4:02:48 PM

DOCUMENT NOT CONSIDERED FINAL UNLESS ALL SIGNATURES COMPLETED

APPROVED  DATE: 5/13/2016

SEAL

DIVISION OF HIGHWAYS
 STATE OF NORTH CAROLINA
 DEPARTMENT OF TRANSPORTATION
 WORK ZONE TRAFFIC CONTROL

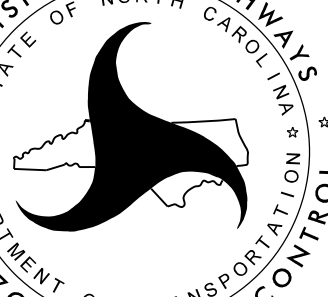

PHASE 2
 STEPS 7 - 11

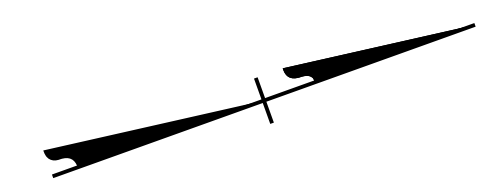

REVISIONS

PLOT DRIVER: NCDOT_pdf_color_eng_50.plt
 USER: erbrooks
 DATE: 5/12/2016
 TIME: 4:03:01 PM
 FILE: c:\pwworking\tpa\d0487729\U-3308_TMP-TMP-23.dgn

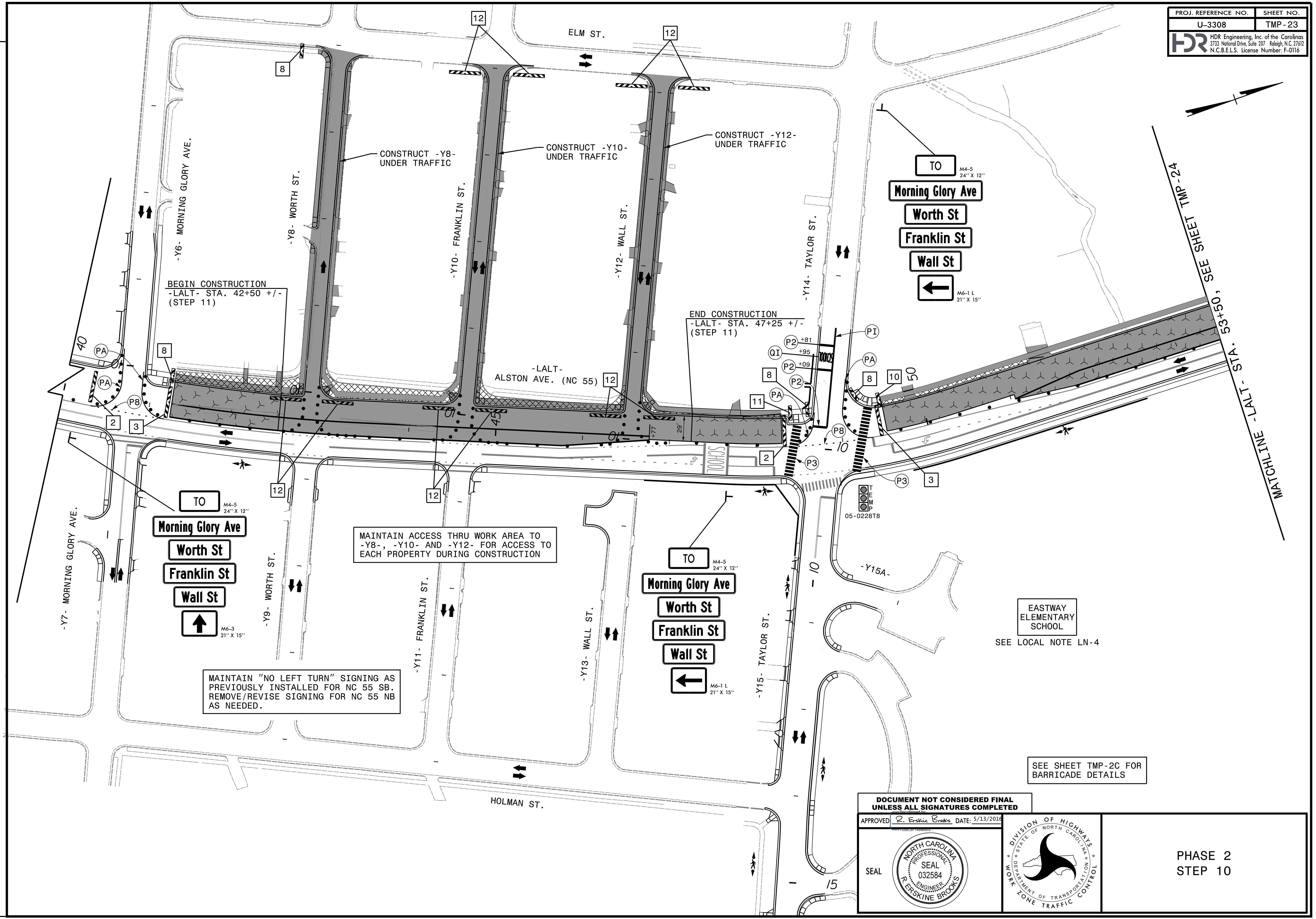

DOCUMENT NOT CONSIDERED FINAL
 UNLESS ALL SIGNATURES COMPLETED

APPROVED:  DATE: 5/13/2016

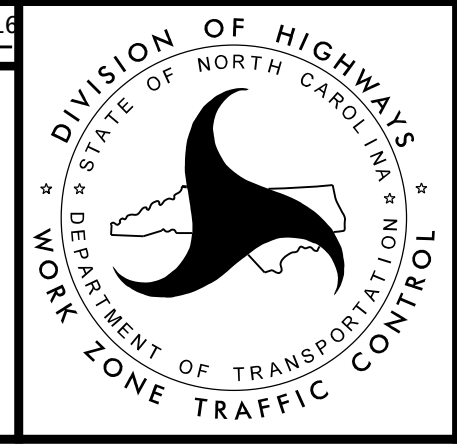

PHASE 2
 STEP 10

PLOT DRIVER: NCDOT_pdf_color_eng_50.plt
USER: erbrooks
PENTABLE: NCDOT_tcp.tbl
DATE: 5/12/2016
TIME: 4:03:11 PM
FILE: c:\pwworking\tpa\0487729\U-3308_TMP-TMP-24.dgn

REVISIONS

PROJ. REFERENCE NO.	SHEET NO.
U-3308	TMP-24
 HDR Engineering, Inc. of the Carolinas 3733 National Drive, Suite 207 Raleigh, N.C. 27612 N.C.B.E.L.S. License Number: F-0116	

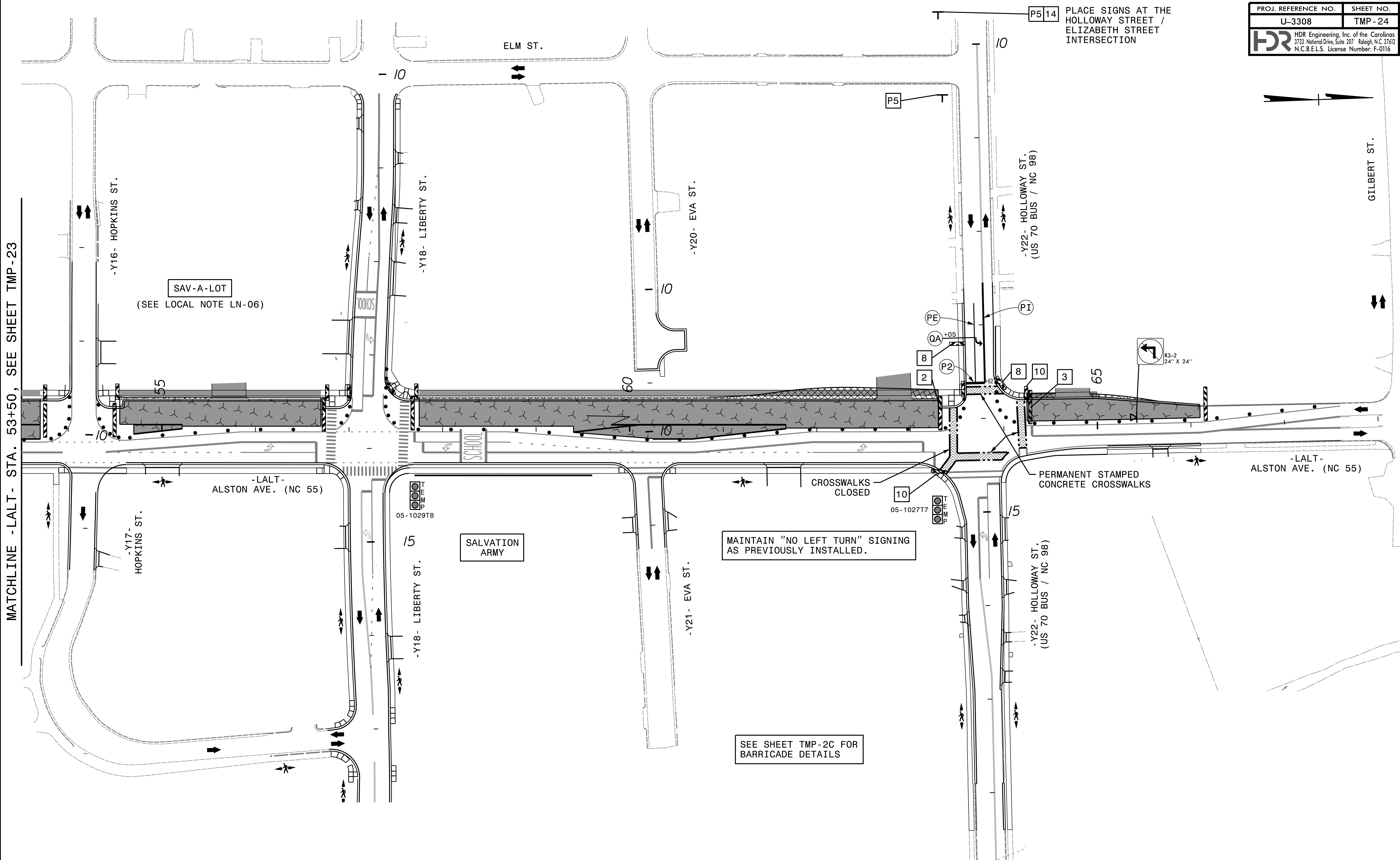

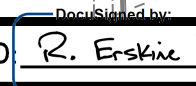
APPROVED:  DATE: 5/13/2016



PHASE 2
STEP 10

DOCUMENT NOT CONSIDERED FINAL
UNLESS ALL SIGNATURES COMPLETED

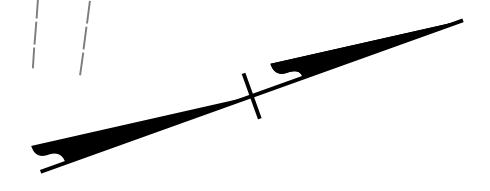

SEE SHEET TMP-4 FOR SECTION A-A

REDUCE NC 55 NB TO ONE LANE USING RSD 1101.02, SHEET 3 OR 5 OF 15

STEP 2, COMPLETE:

- SIDEWALK ON SB SIDE OF -LALT- BRIDGE
- -LALT- FROM STA. 14+58 TO STA. 15+35
- -LALT- FROM STA. 17+62 TO STA. 18+41

(UPON COMPLETION OF ALL BRIDGE WORK AND INSTALLATION OF FINAL TRAFFIC SIGNAL, REMOVE SIDEWALK CLOSURE SIGNING AND BARRICADES AND OPEN FINAL SIDEWALK ADJACENT TO -LALT- SB LANES FROM STA. 13+85 TO STA. 19+75)

CONSTRUCT CONCRETE ISLAND (STEP 1)

CONSTRUCT CONCRETE ISLANDS (STEP 1)

PLACE TEMPORARY MARKINGS IN THE FINAL PATTERN ON -LALT- EXCEPT FROM STA. 16+35 +/- TO STA. 19+19 +/- ON THE SB LANES.

REMOVE TEMPORARY GUARDRAIL AND INSTALL PERMANENT GUARDRAIL IN EXISTING LOCATION

PLACE TEMPORARY MARKINGS IN THE FINAL PATTERN ON -LALT- FROM STA. 20+90 +/- TO STA. 36+00 +/- AND -R2-, -R4-, -R5-, -YA- & -Y3-

USING RSD 1101.02, SHEET 3 OF 15, CLOSE INSIDE LANE TO COMPLETE MEDIAN ISLAND WORK

REVISIONS

PLOT DRIVER: NCDOT_pdf_color_eng_50.plt PENTABLE: NCDOT_tcp.tbl
 USER: erbrooks DATE: 5/12/2016 TIME: 4:03:22 PM
 FILE: c:\pwworking\tpa\d048729\U-3308_TMP-TMP-25.dgn

MATCHLINE -LALT- STA. 26+50, SEE SHEET TMP-26

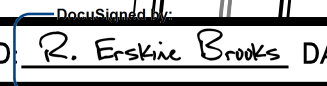
APPROVED  DATE: 5/13/2016

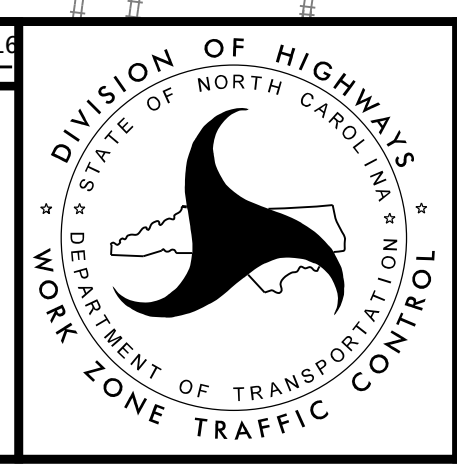
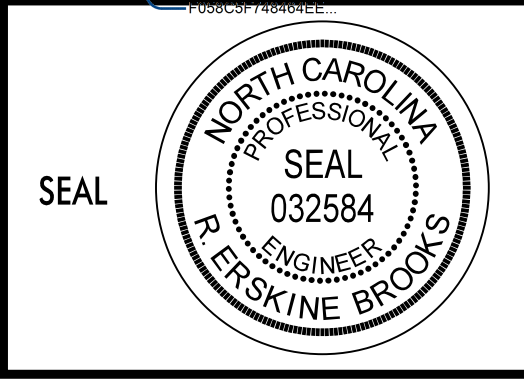

PHASE 3

DOCUMENT NOT CONSIDERED FINAL UNLESS ALL SIGNATURES COMPLETED

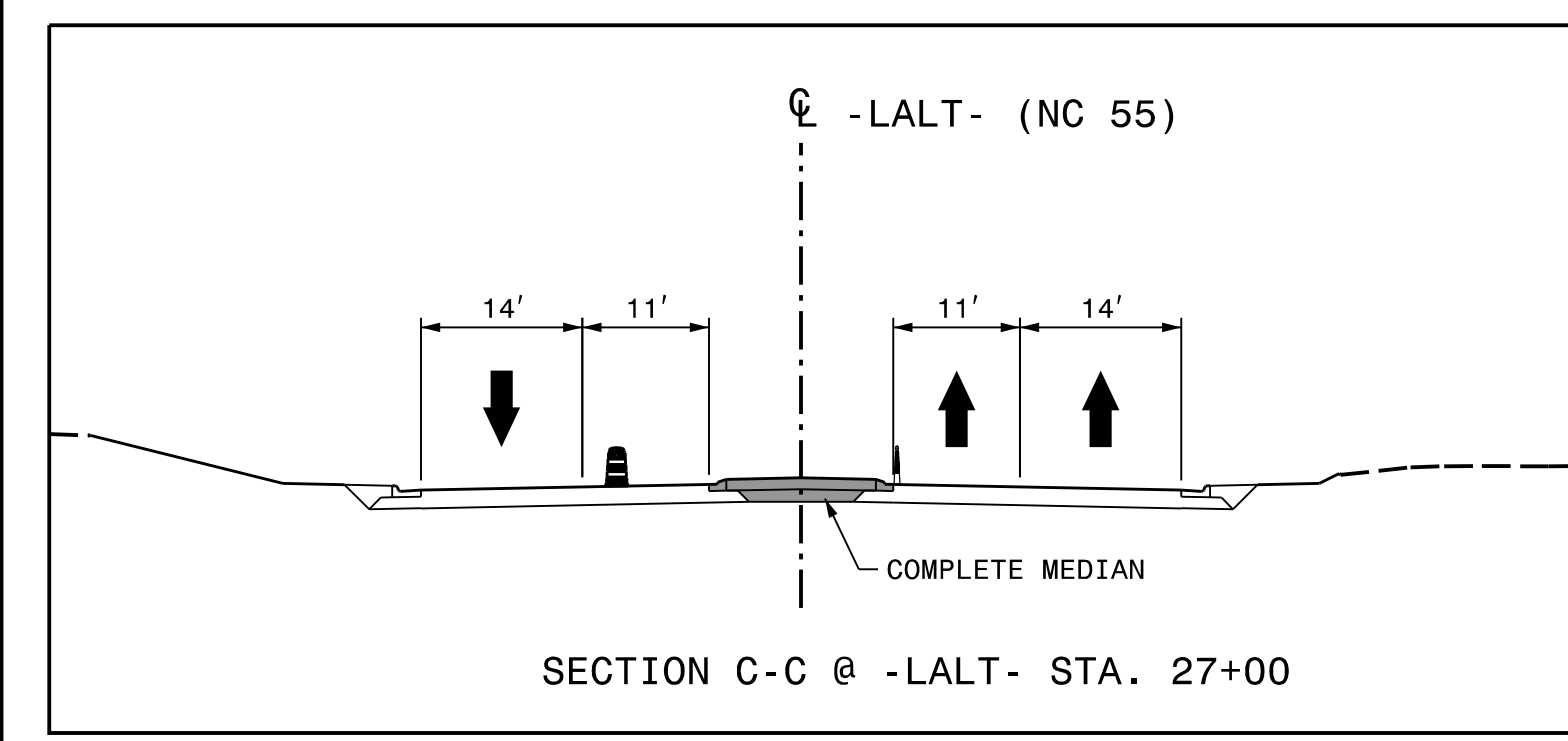
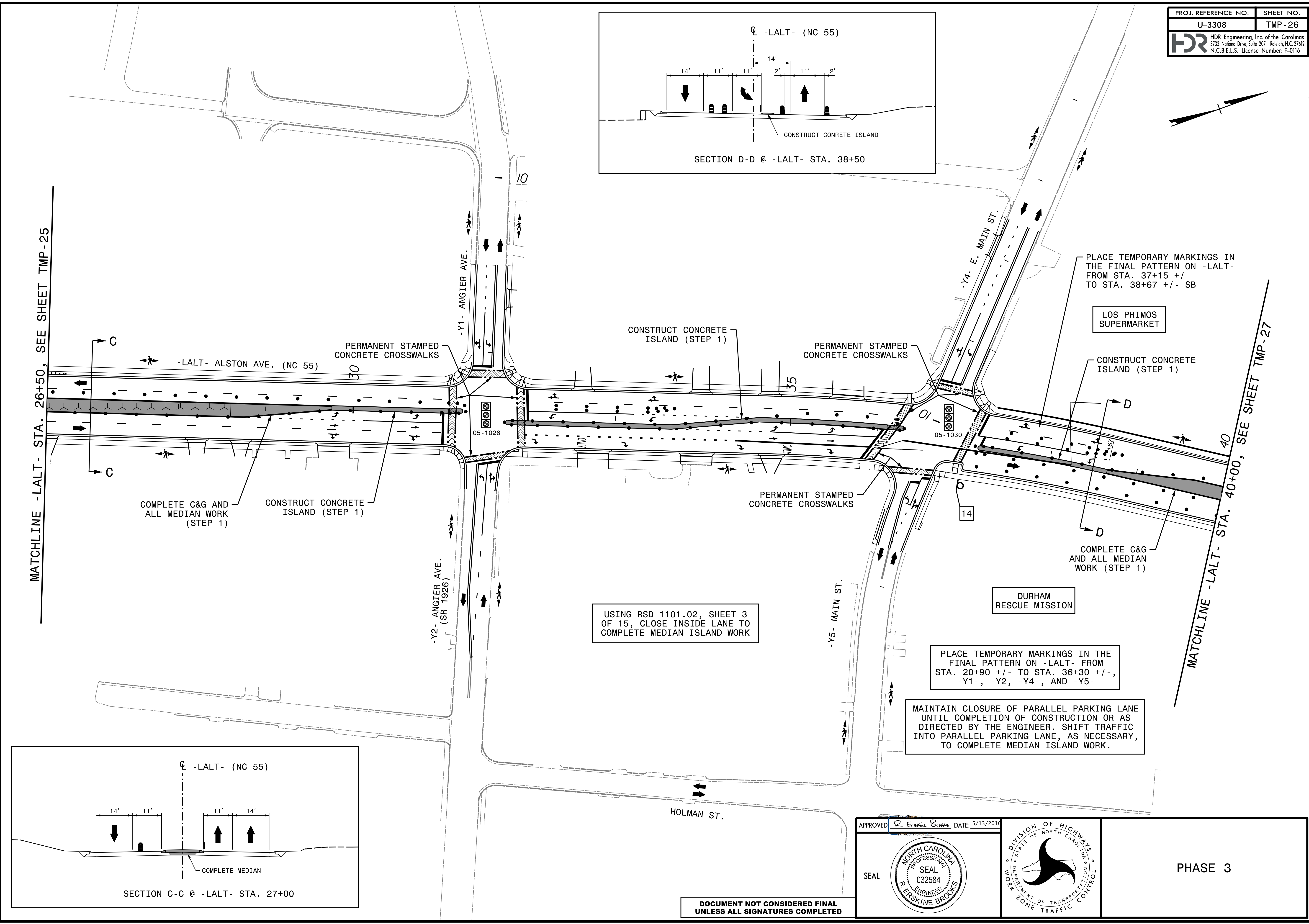
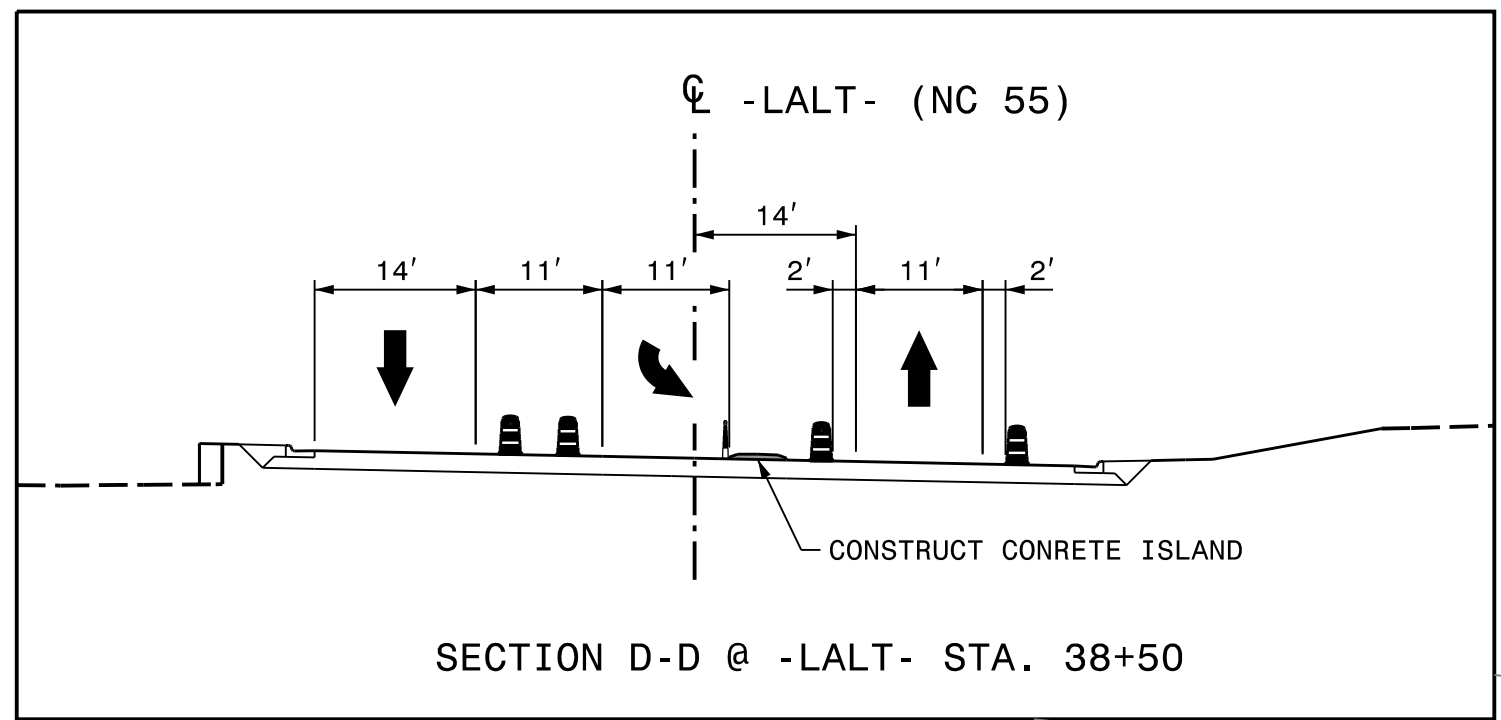
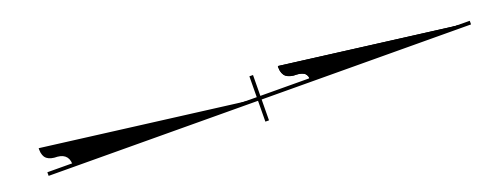

MATCHLINE -LALT- STA. 26+50, SEE SHEET TMP-25

MATCHLINE -LALT- STA. 40+00, SEE SHEET TMP-27

PLACE TEMPORARY MARKINGS IN THE FINAL PATTERN ON -LALT- FROM STA. 37+15 +/- TO STA. 38+67 +/- SB

LOS PRIMOS SUPERMARKET

CONSTRUCT CONCRETE ISLAND (STEP 1)

COMPLETE C&G AND ALL MEDIAN WORK (STEP 1)

DURHAM RESCUE MISSION

PLACE TEMPORARY MARKINGS IN THE FINAL PATTERN ON -LALT- FROM STA. 20+90 +/- TO STA. 36+30 +/-, -Y1-, -Y2-, -Y4-, AND -Y5-

MAINTAIN CLOSURE OF PARALLEL PARKING LANE UNTIL COMPLETION OF CONSTRUCTION OR AS DIRECTED BY THE ENGINEER. SHIFT TRAFFIC INTO PARALLEL PARKING LANE, AS NECESSARY, TO COMPLETE MEDIAN ISLAND WORK.

USING RSD 1101.02, SHEET 3 OF 15, CLOSE INSIDE LANE TO COMPLETE MEDIAN ISLAND WORK

REVISIONS

PLOT DRIVER: NCDOT_pdf_color_eng_50.pit
 USER: erbrooks
 DATE: 5/12/2016
 TIME: 4:03:34 PM
 FILE: c:\pwworking\tpa\d0487729\U-3308_TMP-TMP-26.dgn

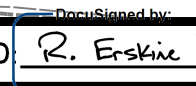
APPROVED  DATE: 5/13/2016

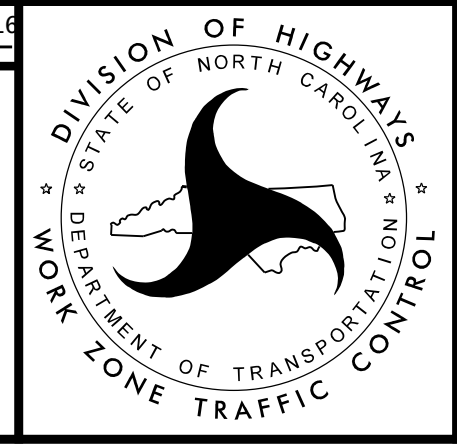
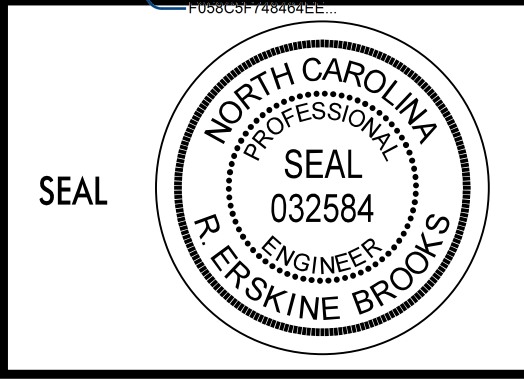

PHASE 3

DOCUMENT NOT CONSIDERED FINAL UNLESS ALL SIGNATURES COMPLETED

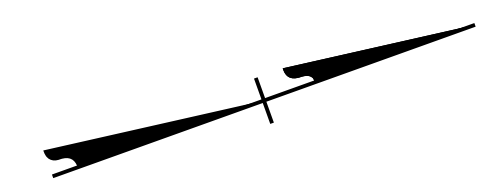

REVISIONS

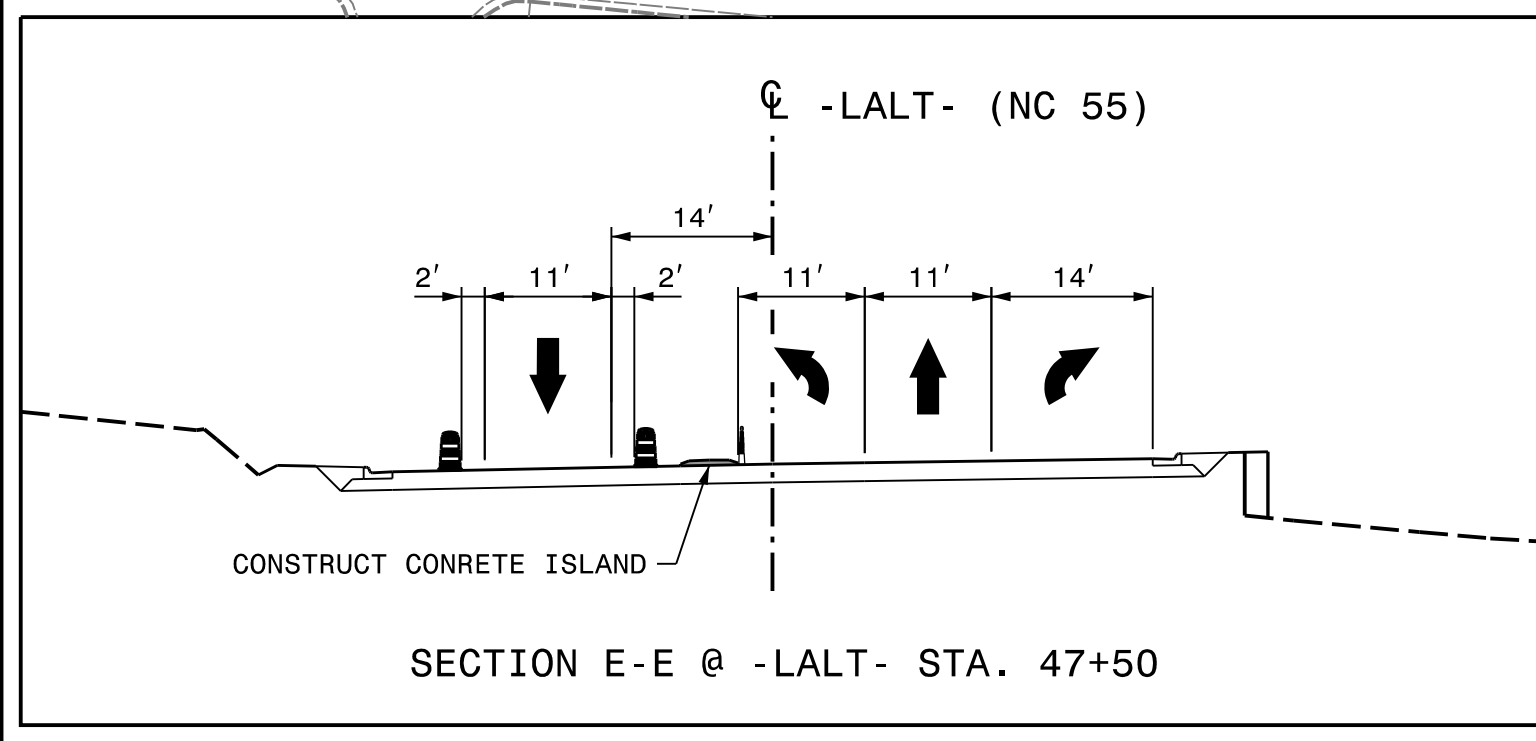
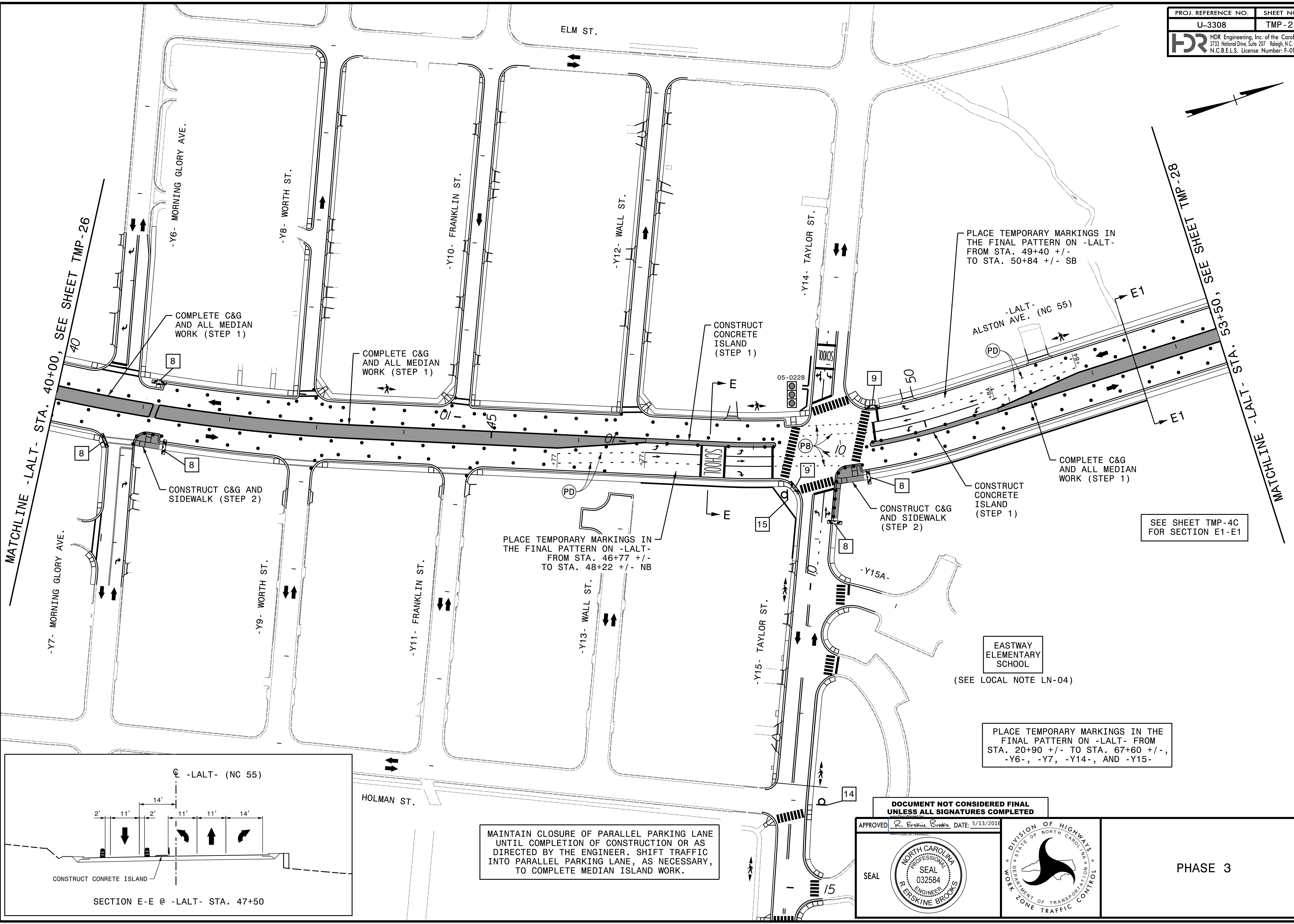

MAINTAIN CLOSURE OF PARALLEL PARKING LANE UNTIL COMPLETION OF CONSTRUCTION OR AS DIRECTED BY THE ENGINEER. SHIFT TRAFFIC INTO PARALLEL PARKING LANE, AS NECESSARY, TO COMPLETE MEDIAN ISLAND WORK.

PLACE TEMPORARY MARKINGS IN THE FINAL PATTERN ON -LALT- FROM STA. 49+40 +/- TO STA. 50+84 +/- SB

PLACE TEMPORARY MARKINGS IN THE FINAL PATTERN ON -LALT- FROM STA. 46+77 +/- TO STA. 48+22 +/- NB

PLACE TEMPORARY MARKINGS IN THE FINAL PATTERN ON -LALT- FROM STA. 20+90 +/- TO STA. 67+60 +/-, -Y6-, -Y7-, -Y14-, AND -Y15-

SEE SHEET TMP-4C FOR SECTION E1-E1

PLOT DRIVER: NCDOT_pdf_color_eng_50.plt
 USER: erbrooks
 DATE: 5/12/2016
 TIME: 4:03:46 PM
 FILE: c:\pwworking\tpa\d048729\U-3308_TMP-TMP-27.dgn

DOCUMENT NOT CONSIDERED FINAL UNLESS ALL SIGNATURES COMPLETED

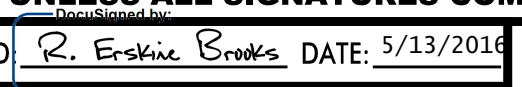
APPROVED:  DATE: 5/13/2016

SEAL: 



PHASE 3

