

PLAN @ END BENT 1 PLAN @ END BENT 2
DIMENSIONS SHOWN ARE TYPICAL FOR BOTH APPROACH SLABS

BILL OF MATERIAL					
FOR ONE APPROACH SLAB (2 REQ'D)					
BAR	NO.	SIZE	TYPE	LENGTH	WEIGHT
* A1	52	#4	STR	25'-9"	894
A2	52	#4	STR	25'-7"	889
* B1	98	#5	STR	24'-1"	2462
B2	98	#6	STR	24'-7"	3619
* B3	5	#4	STR	24'-7"	82
* G1	25	#4	STR	4'-11"	82
* U1	5	#4	1	2'-10"	9
* U2	5	#4	1	4'-0"	13
REINFORCING STEEL				LBS.	4508
* EPOXY COATED REINFORCING STEEL				LBS.	3542
CLASS AA CONCRETE BREAKDOWN					
POUR #1 - APP. SLAB				C. Y.	52.9
POUR #2 - SIDEWALK				C. Y.	3.1
TOTAL				C. Y.	56.0
BAR TYPES					
BAR DIMENSIONS ARE OUT TO OUT					

NOTES

APPROACH SLAB SHALL NOT BE CONSTRUCTED PRIOR TO COMPLETION OF THE BRIDGE DECK.

FOR REINFORCED BRIDGE APPROACH FILL FABRIC WALL INCLUDING GEOTEXTILE, IMPERMEABLE GEOMEMBRANE, 4" Ø DRAINAGE PIPE, #78M STONE, WELDED WIRE FORM, AND SELECT MATERIAL, SEE ROADWAY PLANS.

AREA BETWEEN THE WINGWALL AND APPROACH SLAB SHALL BE GRADED TO DRAIN THE WATER AWAY FROM THE FILL FACE OF THE BRIDGE AND SHALL BE PAVED. SEE ROADWAY PLANS.

THE JOINT OPENING AT THE APPROACH SLAB/DECK INTERFACE SHALL BE SAWED NO MORE THAN 12 HOURS AFTER THE APPROACH SLAB IS CAST. THE JOINT SHALL BE CLEANED OF ALL DEBRIS BEFORE THE SEALANT IS APPLIED. THE JOINT SEALER MATERIAL SHALL CONFORM TO THE REQUIREMENTS OF SECTION 1028-3 OF THE STANDARD SPECIFICATIONS.

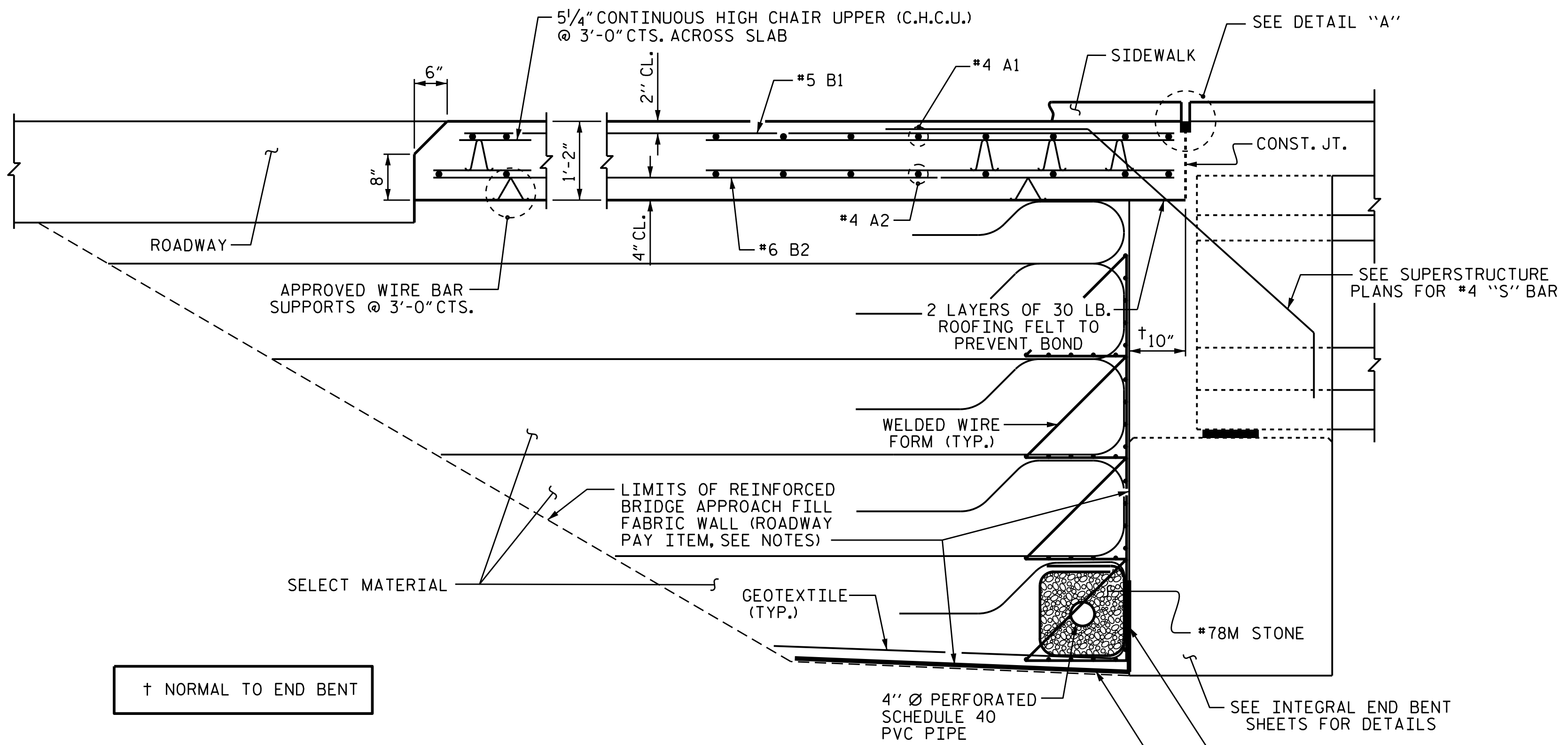

SECTION THRU SLAB

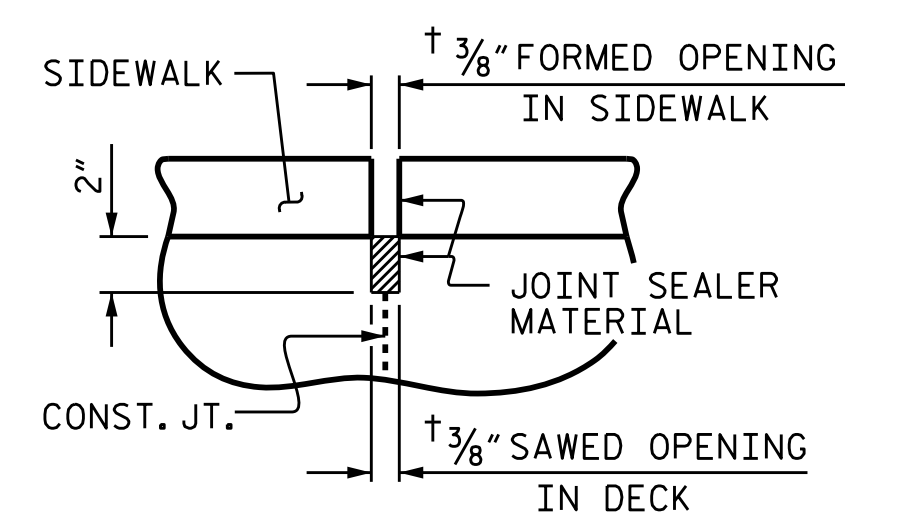

DETAIL "A"

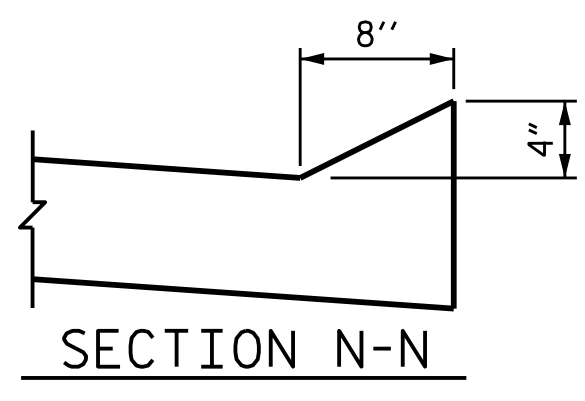

SECTION N-N

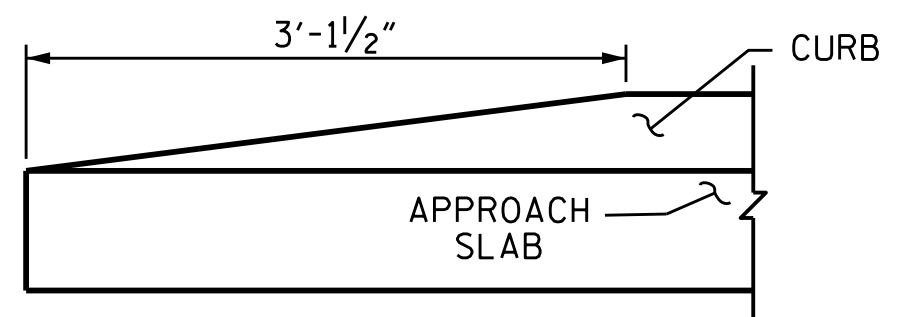

END OF CURB WITHOUT SHOULDER BERM GUTTER

ASSEMBLED BY : T. H. CARROLL	DATE : 06/18/2013
CHECKED BY : R. P. PATEL	DATE : 06/28/13
DRAWN BY : TLA 10/05	REV. 10/1/11 MAA/GM
CHECKED BY : GM 5/06	REV. 12/21/11 MAA/GM
	REV. 6/13 MAA/GM

22-MAR-2016 11:36
R:\Structures\Plans\str2\U3308.sd.AS_02.dgn
jdhawk

DOCUMENT NOT CONSIDERED FINAL UNLESS ALL SIGNATURES COMPLETED

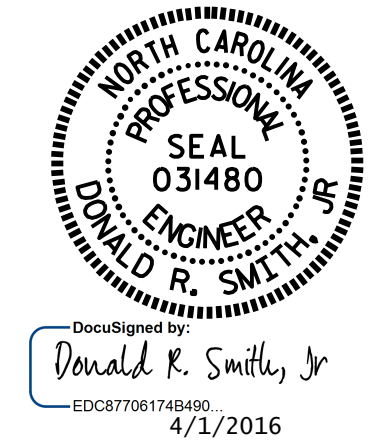

PROJECT NO. U-3308
DURHAM COUNTY
STATION: 23+00.86-LALT-

SHEET 1 OF 2

STATE OF NORTH CAROLINA
DEPARTMENT OF TRANSPORTATION
RALEIGH
STANDARD
BRIDGE APPROACH SLAB
FOR INTEGRAL ABUTMENT

REVISIONS						SHEET NO.
NO.	BY:	DATE:	NO.	BY:	DATE:	S2-31
1			3			TOTAL SHEETS 32
2			4			

STR. #2

STD. NO. BAS5