

DETAIL "A"

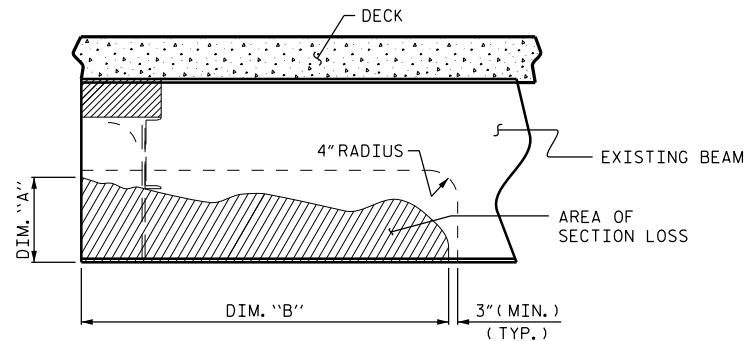

SECTION LOSS BEAM END REPAIR

* NOT NEEDED IF REPAIRED SECTION IS CUT FROM A ROLLED BEAM

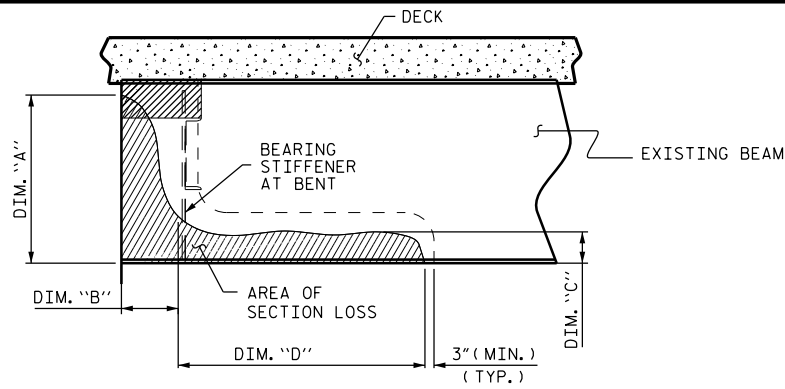

SECTION LOSS BEAM END REPAIR

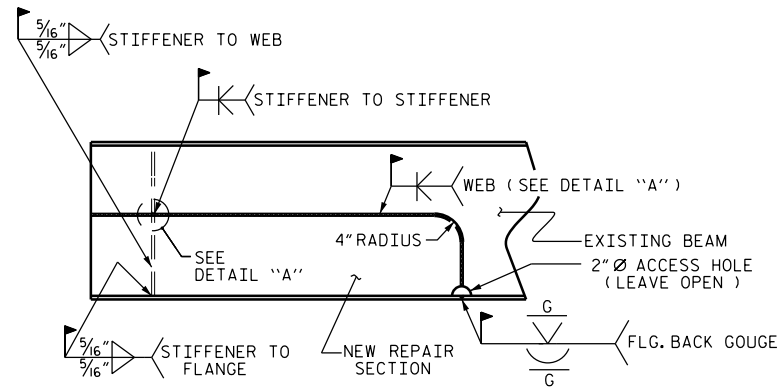

SECTION LOSS BEAM END REPAIR SECTION

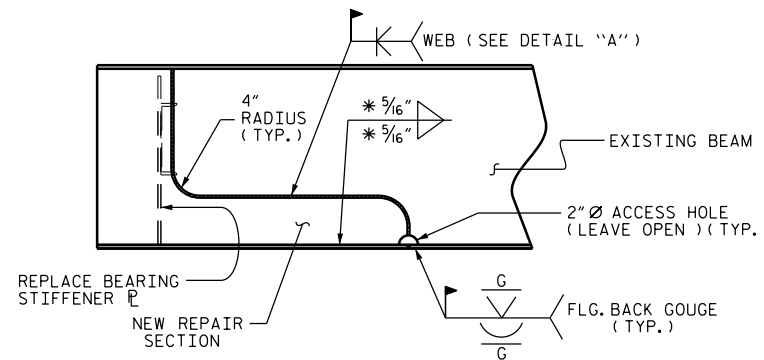

SECTION LOSS BEAM END REPAIR SECTION

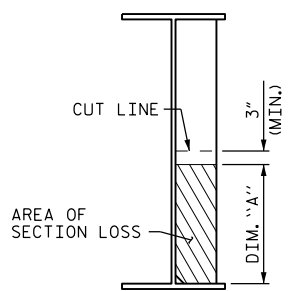

SECTION LOSS STIFFENER/CONN. P REPAIR

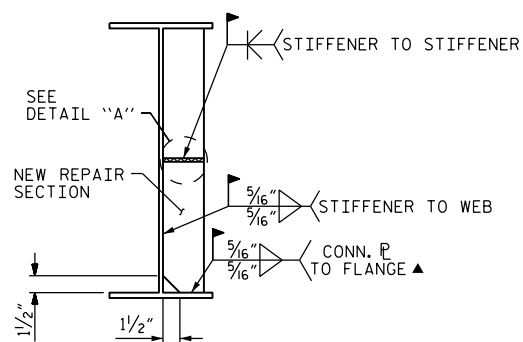

SECTION LOSS STIFFENER/CONN. P REPAIR SECTION

▲ FOR STIFFENERS, MILL TO BEAR AND DO NOT WELD

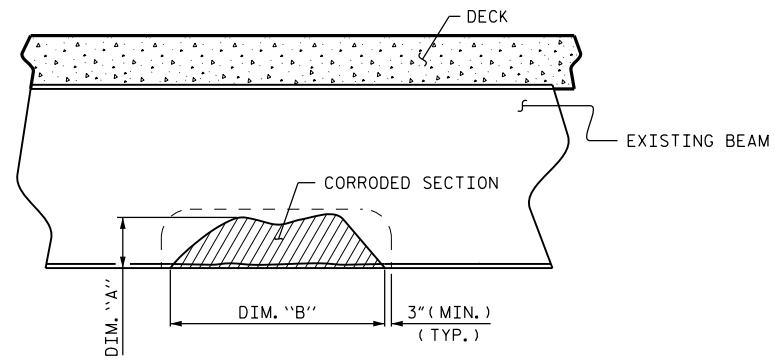

SECTION LOSS INTERMEDIATE BEAM REPAIR

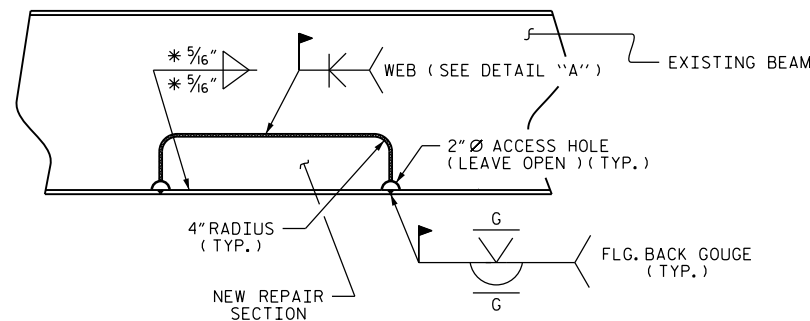

SECTION LOSS INTERMEDIATE BEAM REPAIR SECTION

BEAM REPAIR

AFTER THE STRUCTURAL STEEL HAS BEEN BLASTED AND PRIMED, THE STRUCTURAL STEEL AND BEARING SHALL BE INSPECTED FOR EXCESSIVE SECTION LOSS. AREAS THAT EXHIBIT AN EXCESS OF 35% SECTION LOSS SHALL BE REVIEWED BY THE ENGINEER TO DETERMINE IF AREA OF SECTION LOSS SHOULD BE REPAIRED.

AS DETERMINED BY THE ENGINEER, AREAS WITH EXCESSIVE SECTION LOSS OR AREAS WITH TEMPORARY REPAIRS SHALL BE REMOVED AND THE BEAMS SHALL BE REPAIRED AS INDICATED ON THIS PLAN SHEET. CONTRACTOR AND ENGINEER TO DETERMINE ACTUAL DIMENSIONS OF AREA TO BE REMOVED AND REPLACED. REMOVE CONCRETE BENT DIAPHRAGMS AS NEEDED TO EVALUATE LIMITS OF REPAIR.

PAYMENT FOR THE SECTION REPAIR SHALL BE BASED ON THAT AMOUNT OF REPAIR ACTUALLY PERFORMED BY THE CONTRACTOR AND APPROVED BY THE ENGINEER.

GOUGES AND INDENTIONS FROM IMPACT ON GIRDERS SHALL BE GROUND SMOOTH PRIOR TO BLASTING AND PAINTING OPERATION.

REPAIR SEQUENCE:

REMOVE LIVE LOAD FROM REPAIR AREA BY EITHER CLOSING BRIDGE TO TRAFFIC OR SHIFTING TRAFFIC AWAY FROM REPAIR AREA.

REMOVE DEAD LOAD FROM BEAM BY JACKING AND BLOCKING. CONTRACTOR SHALL SUBMIT JACKING PLAN FOR APPROVAL, PRIOR TO BEGINNING WORK. FOR BRIDGE JACKING, SEE SPECIAL PROVISIONS.

STEEL DIAPHRAGM CHANNELS AND/OR STIFFENERS MAY BE TEMPORARILY REMOVED, IF NECESSARY, AND REPLACED AFTER BEAM REPAIR.

IF BEAM DETERIORATION EXTENDS INTO THE CONCRETE DIAPHRAGM THEN CHIP AWAY CONCRETE TO DETERMINE THE EXTENT OF THE DAMAGE. CUT OUT BY APPROPRIATE MEANS THE DAMAGED BEAM AREA AND/OR BEARING STIFFENER.

MECHANICALLY CLEAN RUST, SCALE, AND EXISTING PAINT TO AT LEAST 3" BEYOND REPAIR AREA.

REPLACEMENT CUT-TO-FIT BEAM SECTION SHALL BE NEW AND FROM SIMILAR SIZE ROLLED BEAM OR APPROVED EQUIVALENT PLATES. THE GRADE OF STEEL SHALL BE AASHTO M270, GRADE 36 OR BETTER.

INSTALL THE CUT-TO-FIT SECTION, FULLY WELD ALONG TOP AND SIDES OF PLATE USING FULL PENETRATION WELDS.

ALL WELDING SHALL BE IN ACCORDANCE WITH CURRENT APPLICABLE AWS AND NCDOT STANDARD SPECIFICATIONS.

ALL WELDS WILL BE INSPECTED AND TESTED BY THE NCDOT MATERIALS AND TEST UNIT IN ACCORDANCE WITH THE CURRENT AWS BRIDGE WELDING CODE AND STANDARD SPECIFICATIONS.

IN ACCORDANCE WITH THE STANDARD SPECIFICATIONS, AFTER REPAIR, GRIND ALL WELDS FLUSH, THOROUGHLY CLEAN AREA TO REMOVE DEBRIS AND OILS FROM REPAIR PROCESS.

CLEANING AND PAINTING OF REPAIRED STRUCTURAL STEEL SHALL BE PERFORMED AS PART OF THE OVERALL CLEANING AND PAINTING CONTRACT.

FOR CLEANING AND PAINTING, SEE PAINTING EXISTING STRUCTURE SPECIAL PROVISIONS.

AFTER BEAMS ARE REPAIRED AND PAINTED, ANY CONCRETE REMOVED FROM THE BENT DIAPHRAGMS SHALL BE CAST BACK. ANY REINFORCING STEEL CUT DURING THE REMOVAL PROCESS SHALL BE SPLICED WITH A SIMILAR SIZE BAR WITH AT LEAST A ONE FOOT SPLICE TO THE EXISTING STEEL. NO SEPARATE PAYMENT SHALL BE MADE FOR CONCRETE AND REINFORCING STEEL AS THIS IS CONSIDERED INCIDENTAL TO THE PAY ITEM "BEAM REPAIR". FOR BEAM REPAIR, SEE SPECIAL PROVISIONS.

LOWER SPAN TO BEAR; CHECK FOR DISTRESS.

REMOVE JACKING EQUIPMENT AND TEMPORARY SUPPORTS.

REMOVE ALL TRAFFIC CONTROL DEVICES.

PROJECT NO. I-5756
HAYWOOD COUNTY
 BRIDGE NO. 183, 205, 208, 209,
222, 223, 224, 228, 230, 231, 232

DocuSigned by:

John A. Yannaccone

7BC36E9C-8704E6

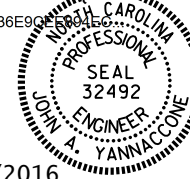

3/21/2016

STATE OF NORTH CAROLINA
 DEPARTMENT OF TRANSPORTATION
 RALEIGH

BEAM END AND INTERMEDIATE REPAIR DETAILS

DRAWN BY : S. T. SANDOR DATE : 11/2014
 CHECKED BY : J. A. YANNACCONI DATE : 12/2014

DOCUMENT NOT CONSIDERED FINAL UNLESS ALL SIGNATURES COMPLETED

REVISIONS						SHEET NO.
NO.	BY:	DATE:	NO.	BY:	DATE:	S-120
1			3			TOTAL SHEETS
2			4			122