

TOP OF CAP

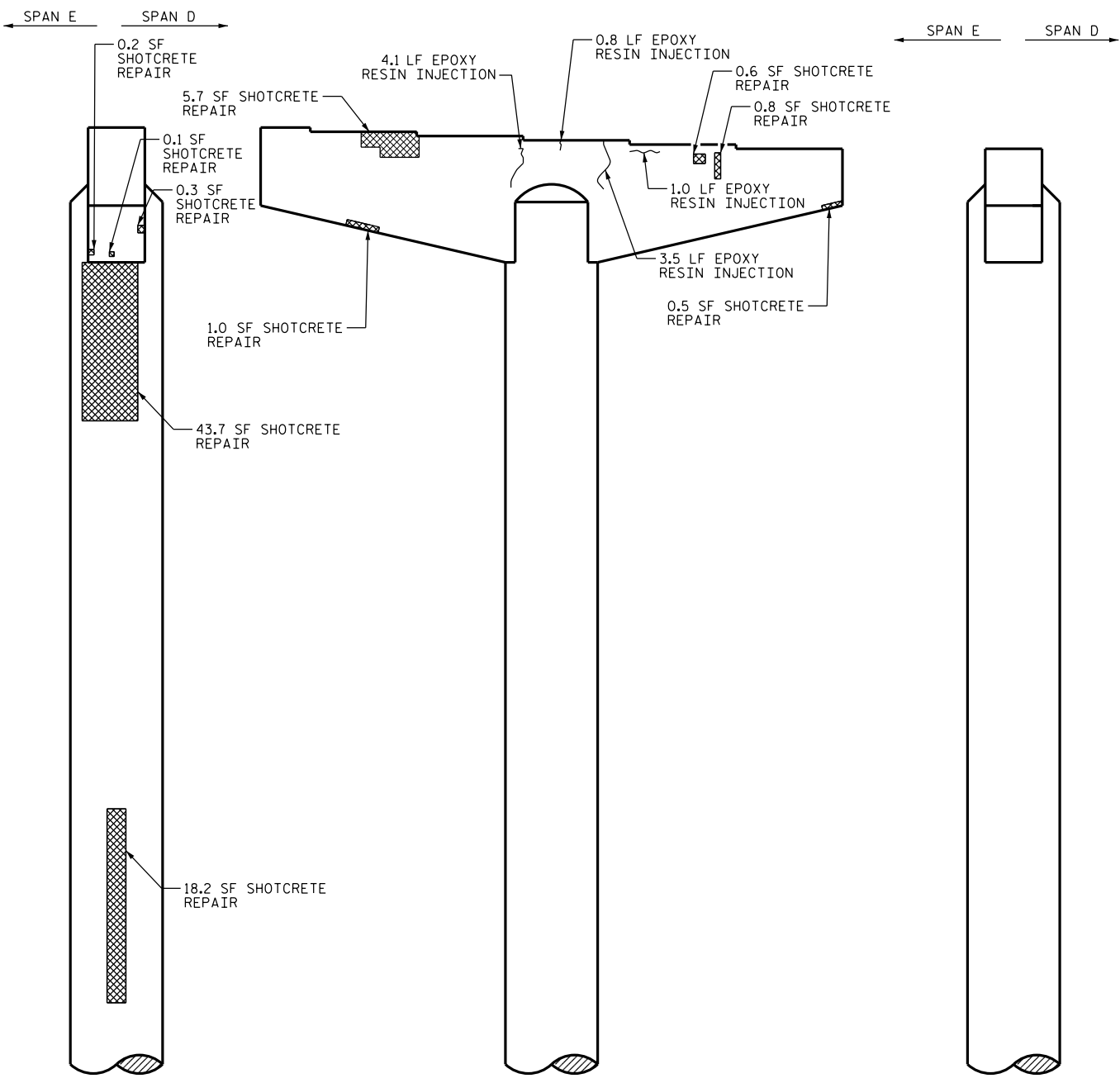

END VIEW

SPAN D FACE

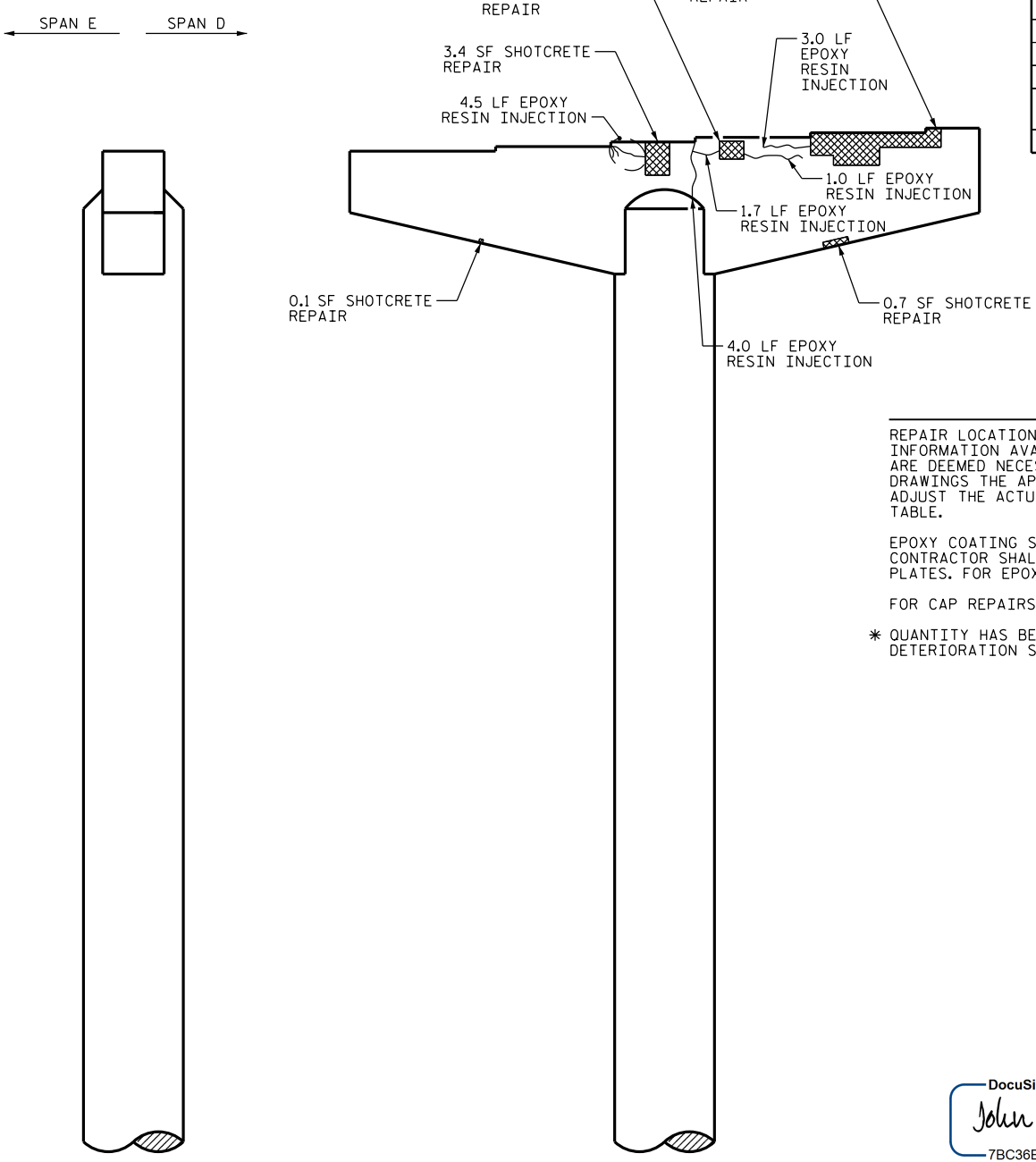

END VIEW

SPAN E FACE

AS-BUILT REPAIR QUANTITY TABLE

REPAIRS BENT 4	QUANTITIES			
	ESTIMATE		ACTUAL	
	AREA SF	VOLUME CF	AREA SF	VOLUME CF
SHOTCRETE REPAIRS				
CAP	27.9	24.7*		
COLUMN	61.9	52.2*		
CONCRETE REPAIRS				
CAP	0.0	0.0		
COLUMN	0.0	0.0		
EPOXY RESIN INJECTION		LN. FT		LN. FT
CAP		28.4		
COLUMN		0.0		
EPOXY COATING		SQ. FT		SQ. FT
TOP OF BENT CAP		164		

VALUES IN CHARTS REPRESENT ESTIMATED REPAIR TOTALS AFTER REMOVAL OF UNSOUND CONCRETE, MIN. OF 1" BEHIND REBAR AND MIN. 1" CLEAR TO SAWCUT.

NOTES

REPAIR LOCATIONS AND ESTIMATED QUANTITIES ARE GIVEN WITH THE BEST INFORMATION AVAILABLE. IF ADDITIONAL REPAIRS NOT SHOWN ON THE DRAWINGS ARE DEEMED NECESSARY BY THE ENGINEER, THE ENGINEER WILL NOTE ON THE DRAWINGS THE APPROXIMATE LOCATIONS AND DESCRIPTION OF THE REPAIRS AND ADJUST THE ACTUAL QUANTITIES ENTERED INTO THE AS-BUILT REPAIR QUANTITY TABLE.

EPOXY COATING SHALL BE APPLIED TO THE TOP FACE OF THE CAP. THE CONTRACTOR SHALL NOT COAT THE AREA OF THE CAP BENEATH THE MASONRY PLATES. FOR EPOXY COATING, SEE SPECIAL PROVISIONS.

FOR CAP REPAIRS, SEE "TYPICAL CAP AND COLUMN REPAIR DETAILS" SHEET.

* QUANTITY HAS BEEN INCREASED DUE TO THE POTENTIAL FOR FURTHER DETERIORATION SINCE THE FIELD INSPECTION BY STRUCTURES MANAGEMENT UNIT.



PROJECT NO. I-5756
HAYWOOD COUNTY
 BRIDGE NO. 230

SHEET 4 OF 4

DocuSigned by:
John A. Yannaccone
 7BC36E9CE888C

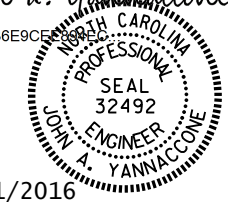

3/21/2016

STATE OF NORTH CAROLINA
 DEPARTMENT OF TRANSPORTATION
 RALEIGH

BENT 4

DRAWN BY : H. T. BARBOUR DATE : 09/15
 CHECKED BY : J. YANNACCONE DATE : 12/15

REVISIONS						SHEET NO.
NO.	BY:	DATE:	NO.	BY:	DATE:	S-98
1			3			TOTAL SHEETS
2			4			122

DOCUMENT NOT CONSIDERED FINAL UNLESS ALL SIGNATURES COMPLETED