

LOAD AND RESISTANCE FACTOR RATING (LRFR)  
SUMMARY FOR REINFORCED CONCRETE BOX CULVERTS

LEVEL	VEHICLE	WEIGHT (W) (TONS)	CONTROLLING LOAD RATING Ⓝ	MINIMUM RATING FACTORS (RF)	TONS = W x RF	STRENGTH I LIMIT STATE								COMMENT NUMBER		
						MOMENT				SHEAR						
						LIVE-LOAD FACTORS (LL)	RATING FACTOR	BOX NO.	ELEMENT TYPE	DISTANCE FROM LEFT END OF ELEMENT (ft)	RATING FACTOR	BOX NO.	ELEMENT TYPE		DISTANCE FROM LEFT END OF ELEMENT (ft)	
DESIGN LOAD RATING	HL-93 (INVENTORY)	N/A	Ⓛ	1.02	--	1.75	1.46	1	TOP SLAB	3.87	1.02	1	TOP SLAB	8.49		
	HL-93 (OPERATING)	N/A		1.33	--	1.35	1.90	1	TOP SLAB	3.87	1.33	1	TOP SLAB	8.49		
	HS-20 (INVENTORY)	36.00	Ⓜ	1.13	40.51	1.75	1.47	1	TOP SLAB	4.11	1.13	1	BOTTOM SLAB	8.73		
	HS-20 (OPERATING)	36.00		1.46	52.51	1.35	1.91	1	TOP SLAB	4.11	1.46	1	BOTTOM SLAB	8.73		
LEGAL LOAD RATING	SINGLE VEHICLE (SV)	SNSH	13.50		2.16	29.15	1.40	2.69	1	TOP SLAB	4.11	2.16	1	TOP SLAB	8.49	
		SNGARBS2	20.00		2.02	40.42	1.40	2.51	1	TOP SLAB	4.11	2.02	1	TOP SLAB	8.49	
		SNAGRIS2	22.00		2.05	45.00	1.40	2.69	1	TOP SLAB	4.11	2.05	1	BOTTOM SLAB	8.73	
		SNCOTTS3	27.25		1.29	35.08	1.40	1.83	1	TOP SLAB	3.87	1.29	1	TOP SLAB	8.49	
		SNAGGRS4	34.93		1.31	45.72	1.40	1.88	1	BOTTOM SLAB	8.94	1.31	1	BOTTOM SLAB	8.73	
		SNS5A	35.55		1.45	51.54	1.40	2.06	1	BOTTOM SLAB	8.94	1.45	1	BOTTOM SLAB	8.73	
		SNS6A	39.95		1.28	51.07	1.40	1.95	1	BOTTOM SLAB	8.94	1.28	1	BOTTOM SLAB	8.73	
		SNS7B	42.00		1.34	56.35	1.40	1.95	1	BOTTOM SLAB	8.94	1.34	1	BOTTOM SLAB	8.73	
	TRUCK TRACTOR SEMI-TRAILER (TTST)	TNAGRIT3	33.00		1.62	53.36	1.40	2.41	1	BOTTOM SLAB	8.94	1.62	1	BOTTOM SLAB	8.73	
		TNT4A	33.08		1.54	50.87	1.40	2.18	1	TOP SLAB	3.87	1.54	1	TOP SLAB	8.49	
		TNT6A	41.60		1.45	60.31	1.40	2.05	1	BOTTOM SLAB	8.94	1.45	1	BOTTOM SLAB	8.73	
		TNT7A	42.00		1.42	59.52	1.40	2.17	1	BOTTOM SLAB	8.94	1.42	1	BOTTOM SLAB	8.73	
		TNT7B	42.00		1.53	64.34	1.40	2.16	1	BOTTOM SLAB	8.94	1.53	1	BOTTOM SLAB	8.73	
		TNAGRIT4	43.00		1.39	59.60	1.40	1.99	1	BOTTOM SLAB	8.94	1.39	1	BOTTOM SLAB	8.73	
TNAGT5A	45.00		1.19	53.37	1.40	1.74	1	BOTTOM SLAB	8.94	1.19	1	BOTTOM SLAB	8.73			
TNAGT5B	45.00		Ⓞ	1.09	48.93	1.40	1.62	1	BOTTOM SLAB	8.94	1.09	1	BOTTOM SLAB	8.73		

LOAD FACTORS:

DESIGN LOAD RATING FACTORS

LOAD TYPE	MAX FACTOR	MIN FACTOR
DC	1.25	0.90
DW	1.50	0.65
EV	1.30	0.90
EH	1.35	0.90
ES	1.35	0.90
LS	1.75	--
WA	1.00	--

NOTE:

RATING FACTORS ARE BASED ON THE STRENGTH I LIMIT STATE.

Ⓝ	CONTROLLING LOAD RATING
Ⓛ	DESIGN LOAD RATING (HL-93)
Ⓜ	DESIGN LOAD RATING (HS-20)
Ⓞ	LEGAL LOAD RATING **
** SEE CHART FOR VEHICLE TYPE	

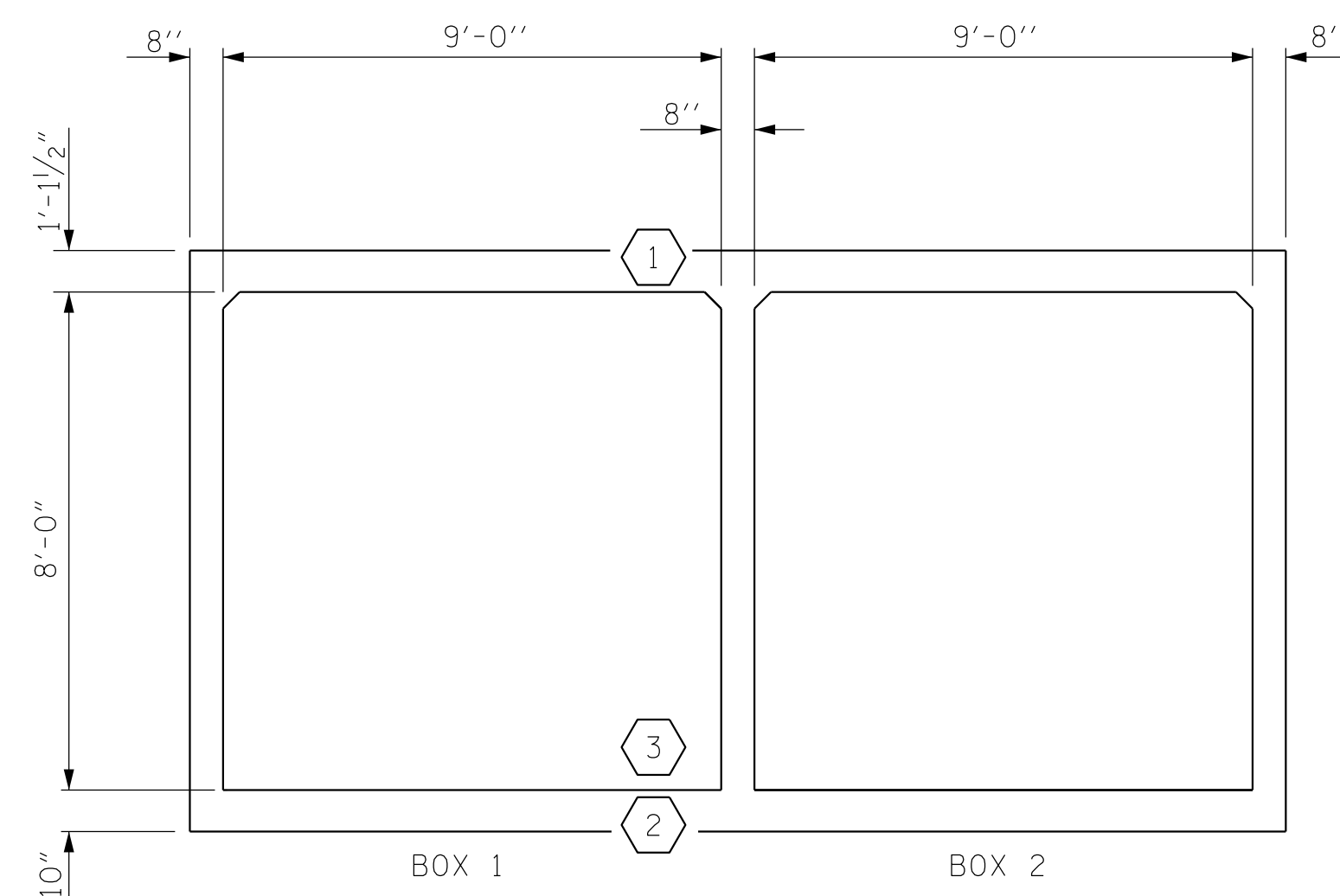

LRFR SUMMARY  
(LOOKING DOWNSTREAM)

PROJECT NO. B-5147  
ASHE COUNTY  
 STATION: 10+66.00 -L-

SHEET 9 OF 9

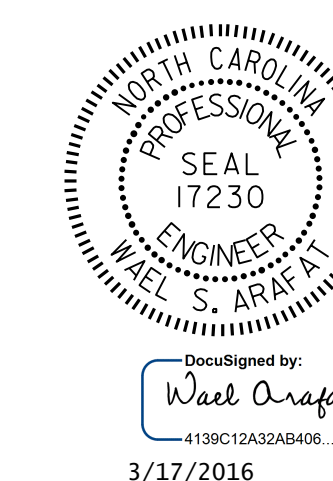

STATE OF NORTH CAROLINA  
 DEPARTMENT OF TRANSPORTATION  
 RALEIGH  
 STANDARD  
 LRFR SUMMARY FOR  
 REINFORCED CONCRETE  
 BOX CULVERTS  
 (NON-INTERSTATE TRAFFIC)

NO.	REVISIONS			NO.	REVISIONS			SHEET NO.
	BY:	DATE:			BY:	DATE:		
1				3			C-9	
2				4			TOTAL SHEETS 9	

DOCUMENT NOT CONSIDERED  
 FINAL UNLESS ALL  
 SIGNATURES COMPLETED

ASSEMBLED BY : V.X. NGUYEN DATE : 12-10-15  
 CHECKED BY : H.T. BABOUR DATE : 1-4-16  
 DRAWN BY : WMC 7/11 REV. 10/1/11 MAA/GM  
 CHECKED BY : GM 7/11