

PROJECT REFERENCE NO. U-2707	SHEET NO. RF-3
RW SHEET NO.	
ROADWAY DESIGN ENGINEER	HYDRAULICS ENGINEER

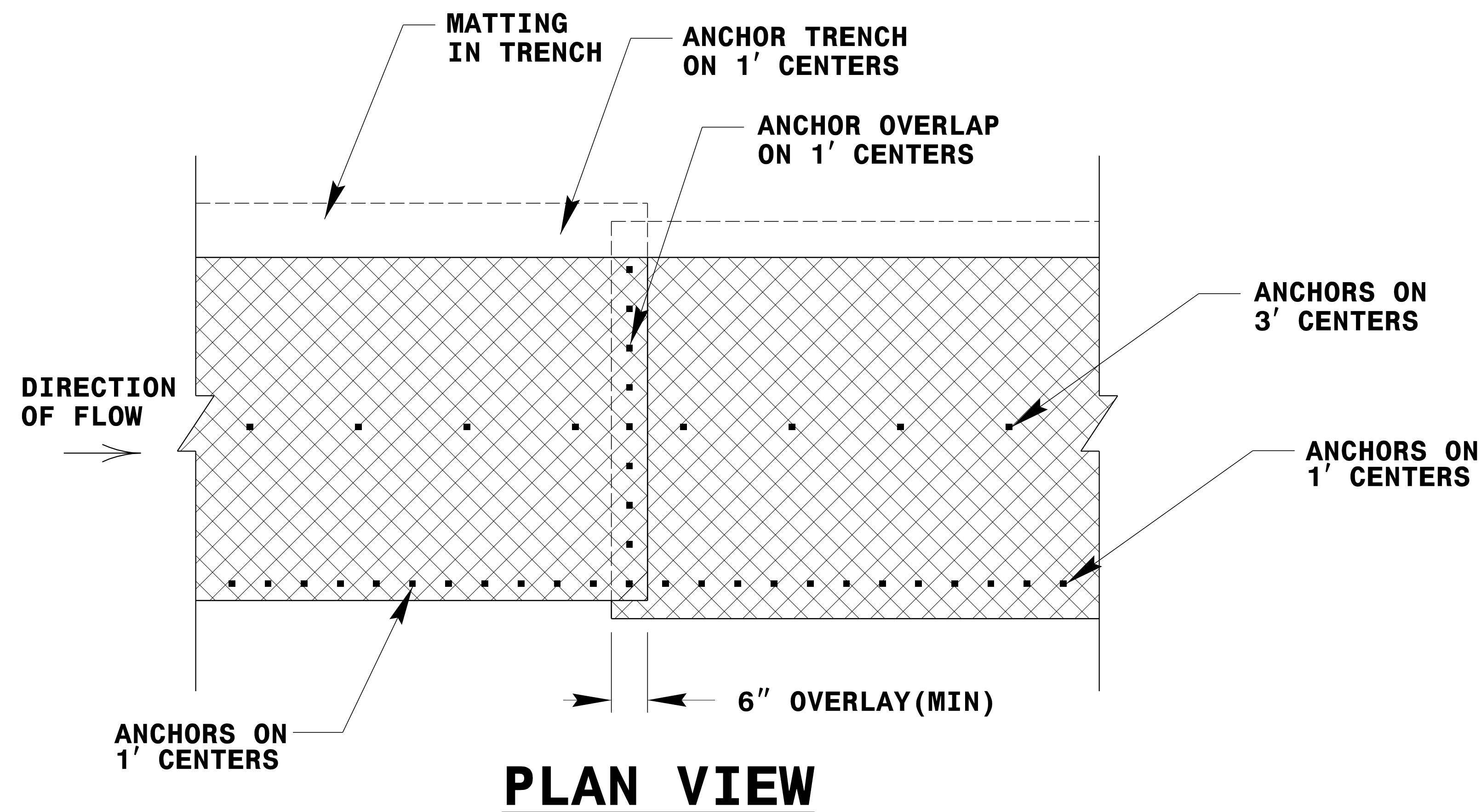

**PLAN VIEW**

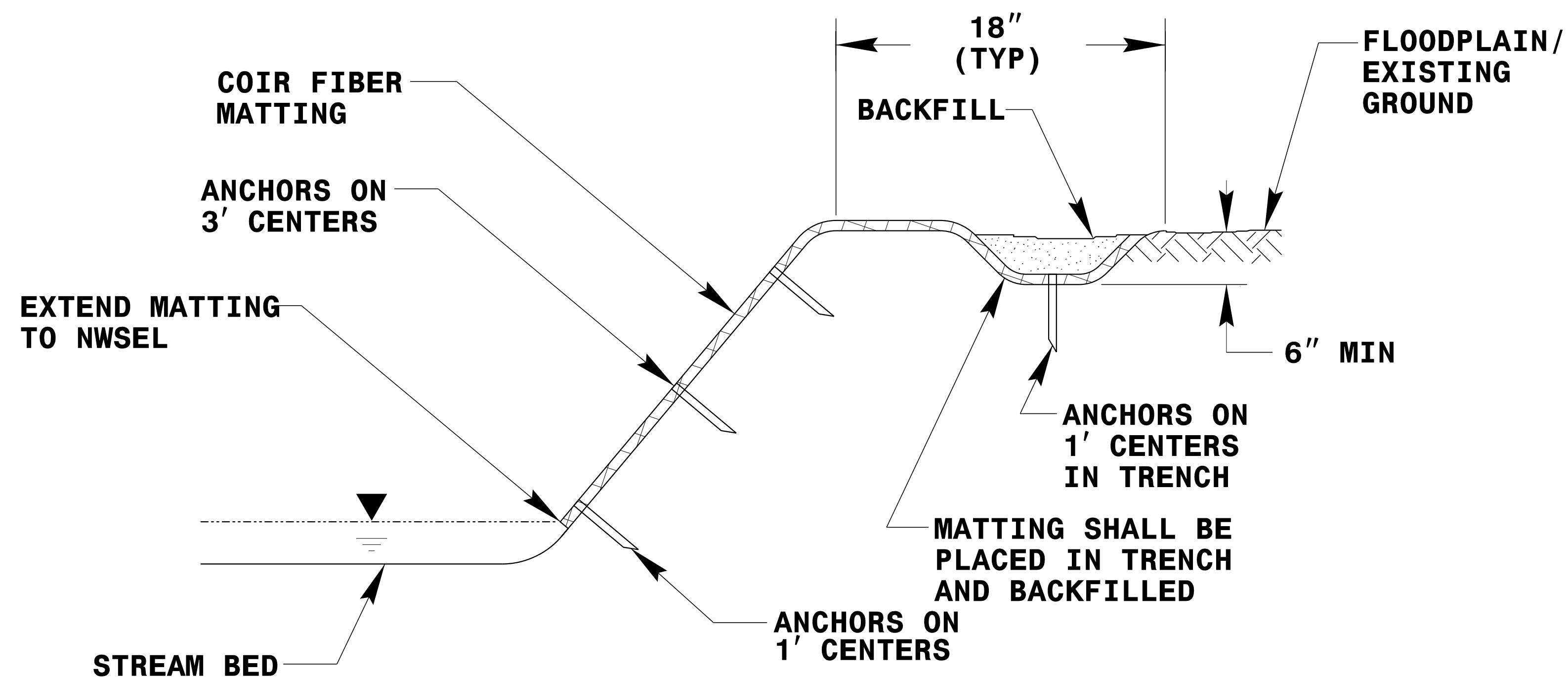

**TYPICAL CROSS SECTION**

**COIR FIBER MATTING DETAIL**

NOT TO SCALE

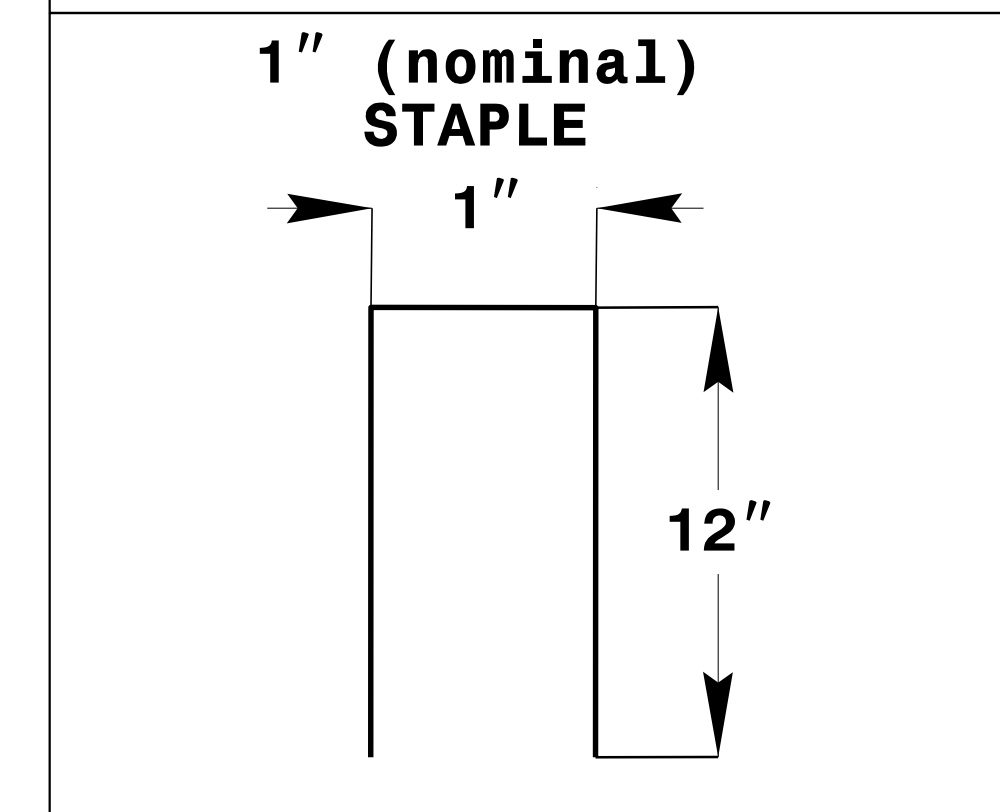
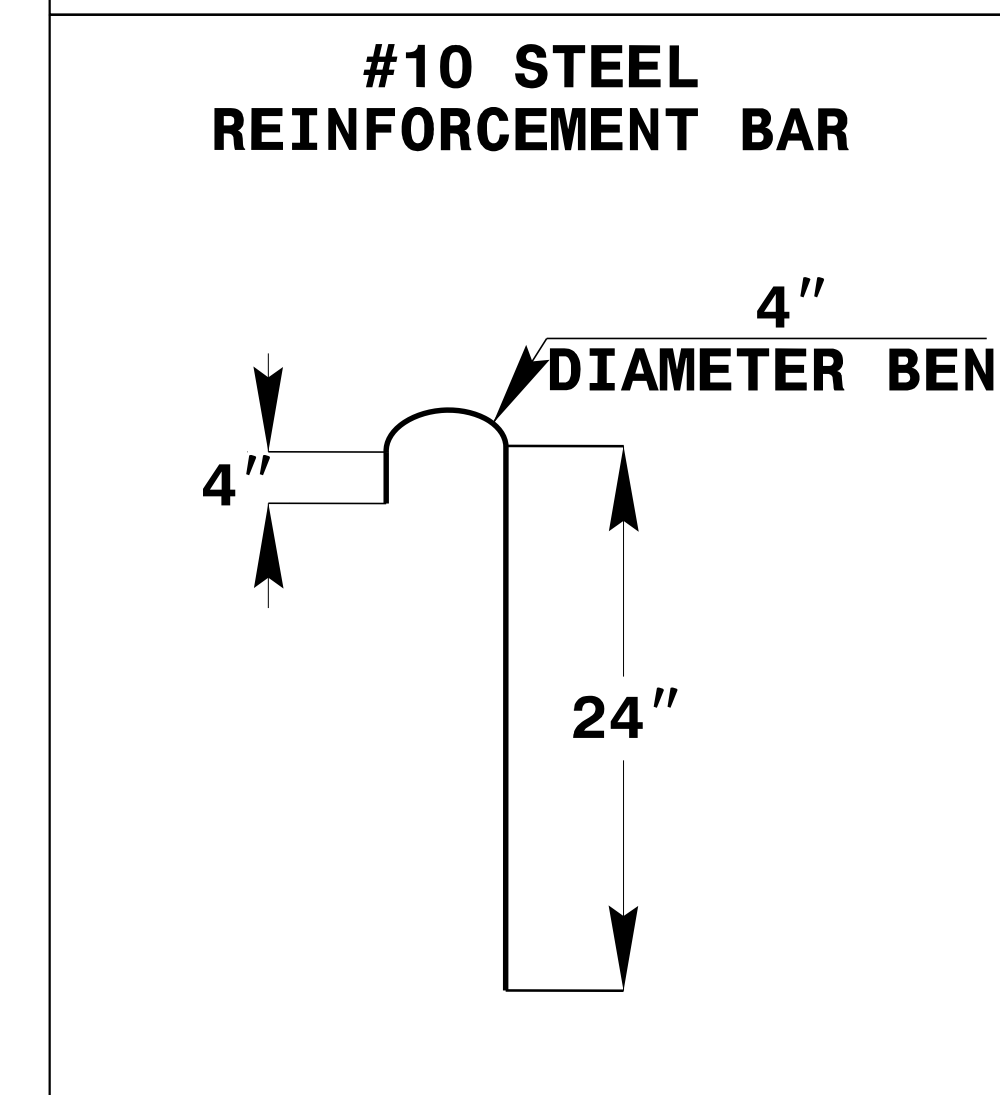
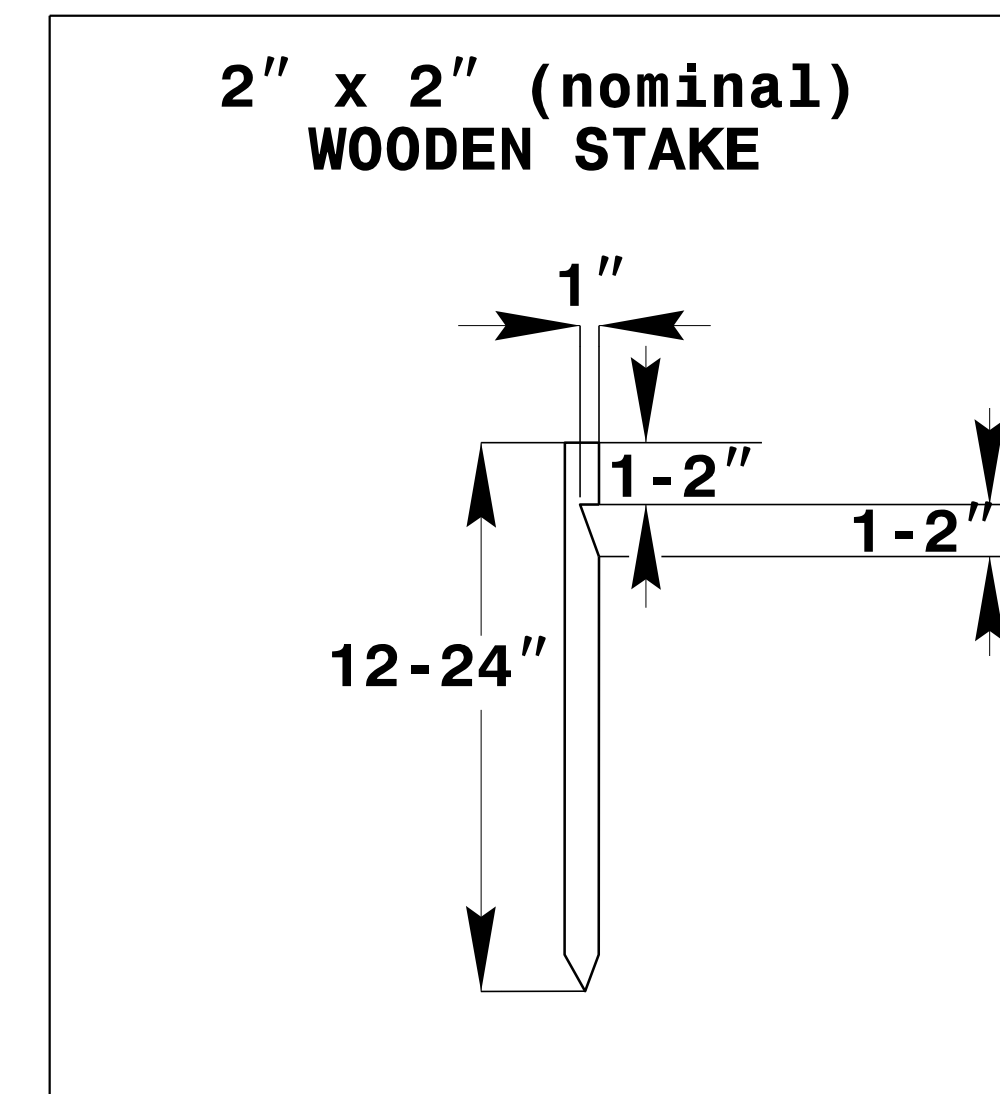

**ANCHOR OPTIONS**

**STREAMBANK REFORESTATION**  
**DETAIL SHEET 2 OF 2**  
N.C.D.O.T. - ROADSIDE ENVIRONMENTAL UNIT