

SECTION B-B

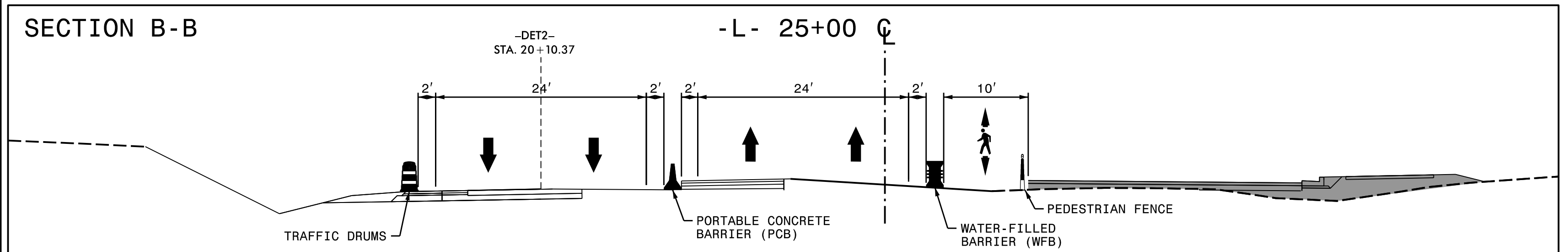

PROJ. REFERENCE NO. B-5123	SHEET NO. TMP-9
HDR Engineering, Inc. of the Carolinas 555 Fayetteville St., Suite 900 Raleigh, N.C. 27601 N.C.B.E.L.S. License Number: F-0116	

* PLACE CRYSTAL/RED TEMPORARY RAISED MARKERS (MI) @ 20' SPACING ALONG THE CENTER LINE OF THE DETOUR ALIGNMENT

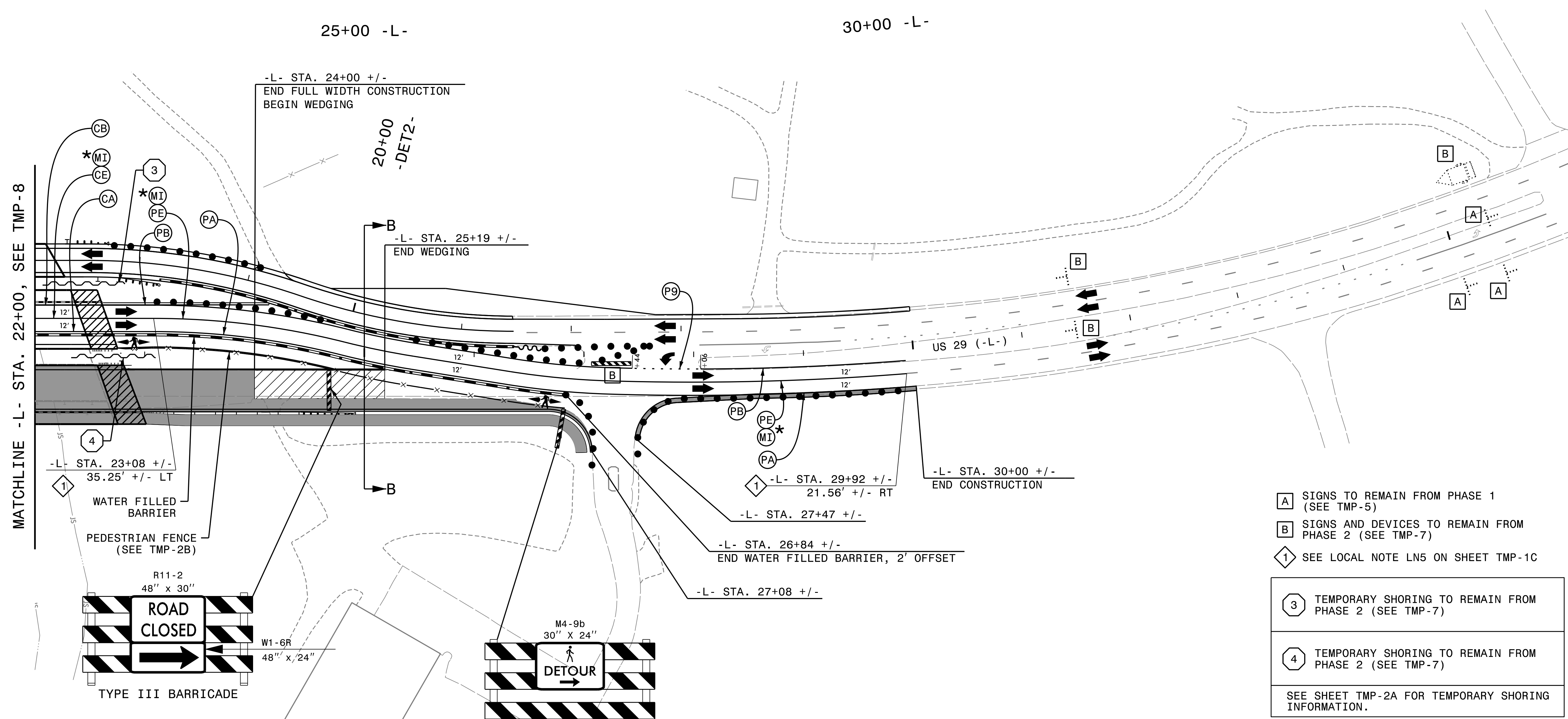

- A SIGNS TO REMAIN FROM PHASE 1 (SEE TMP-5)
 - B SIGNS AND DEVICES TO REMAIN FROM PHASE 2 (SEE TMP-7)
 - 1 SEE LOCAL NOTE LN5 ON SHEET TMP-1C
 - 3 TEMPORARY SHORING TO REMAIN FROM PHASE 2 (SEE TMP-7)
 - 4 TEMPORARY SHORING TO REMAIN FROM PHASE 2 (SEE TMP-7)
- SEE SHEET TMP-2A FOR TEMPORARY SHORING INFORMATION.

PLOT DRIVER: NCDOT_color_eng_50.plt
 USER: CHARNDEN
 DATE: 1/29/2016
 TIME: 9:43:25 AM
 FILE: p:\PWAPP\TPA01\SouthEast-Tampa\Documents\000166\CON0079159\CON0104476\00000000272555\6.0.CAD.BIM\6.2.Work_In_Progress\TrafficControl\TCP\B-5123_TC_TMP_09-Phase3a-2.dgn

APPROVED: <i>Ben Schoenbauer</i> DATE: 1/29/2016 		<p>PHASE 3 STEPS 1 & 2</p>
<p>DOCUMENT NOT CONSIDERED FINAL UNLESS ALL SIGNATURES COMPLETED</p>		