

**This electronic collection of documents is provided
for the convenience of the user
and is Not a Certified Document –**

**The documents contained herein were originally issued
and sealed by the individuals whose names and license
numbers appear on each page, on the dates appearing
with their signature on that page.**

**This file or an individual page
shall not be considered a certified document.**

09/08/99

See Sheet 1-A For Index of Sheets

STATE OF NORTH CAROLINA DIVISION OF HIGHWAYS

ROWAN COUNTY

**LOCATION: INTERSTATE 85 FROM US 601 (JAKE ALEXANDER BLVD.)
TO 0.5 MILE SOUTH OF US 52 (INNES ST.) IN SALISBURY**

**TYPE OF WORK: DRAINAGE, PAVEMENT REHABILITATION,
AND BRIDGE PRESERVATION**

STATE	STATE PROJECT REFERENCE NO.	SHEET NO.	TOTAL SHEETS
N.C.	I-5741	1	
STATE PROJ. NO.	F. A. PROJ. NO.	DESCRIPTION	
52022.1.1	NHPP-0085(022)	PE	
52022.3.1	NHPP-0085(022)	CONST	

TIP PROJECT: I-5741

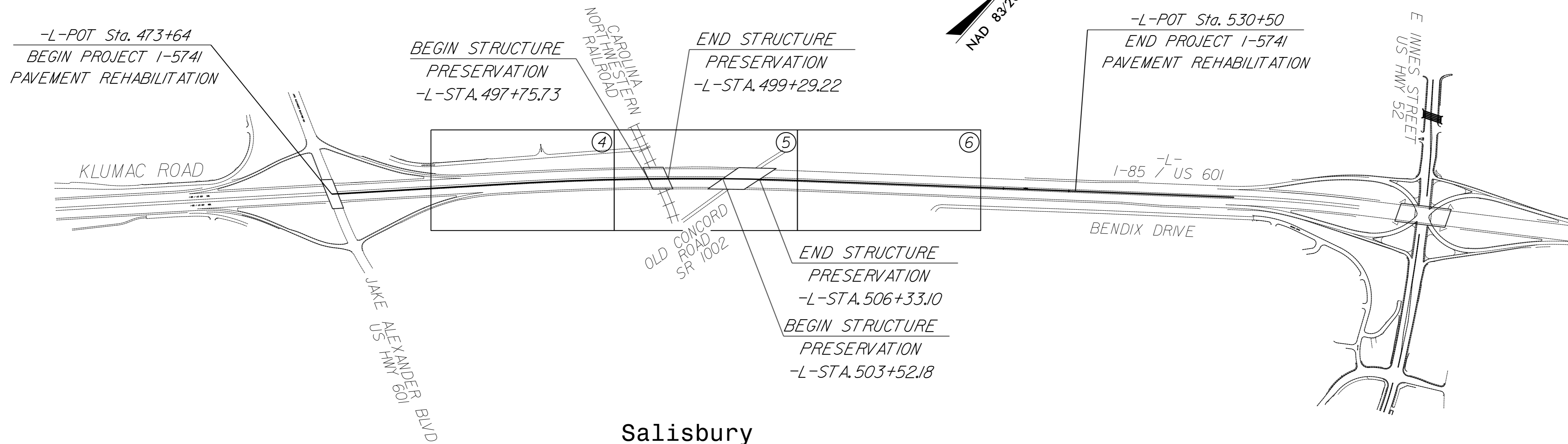
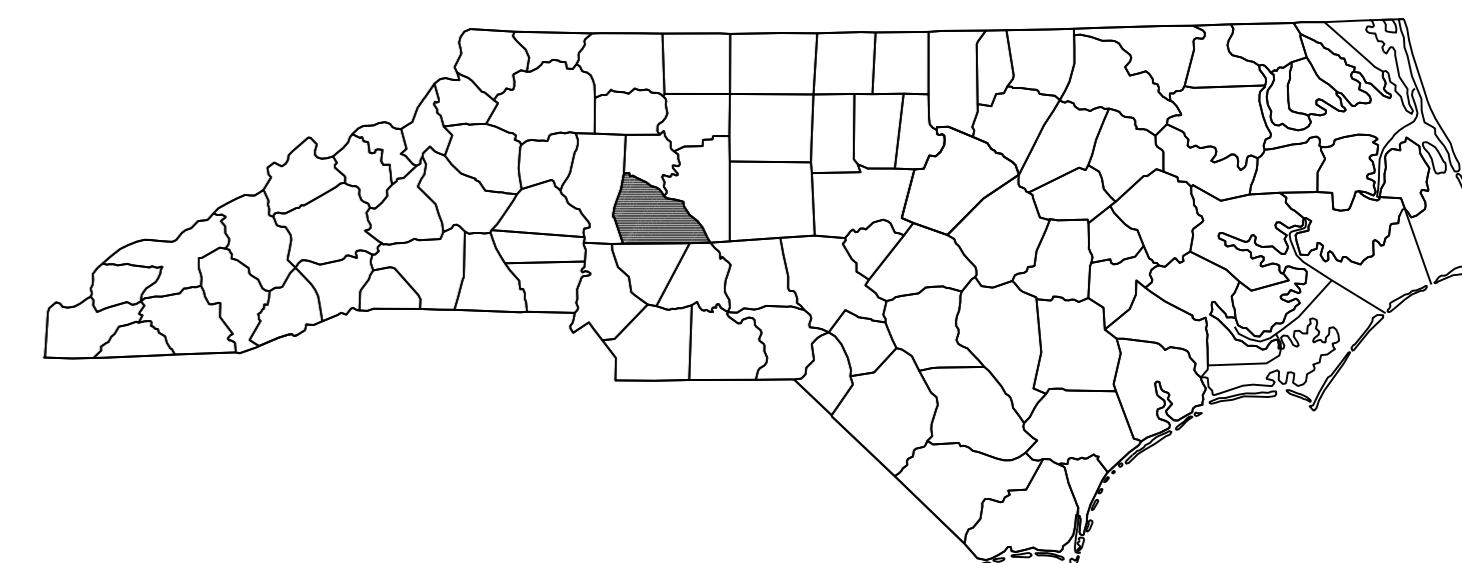
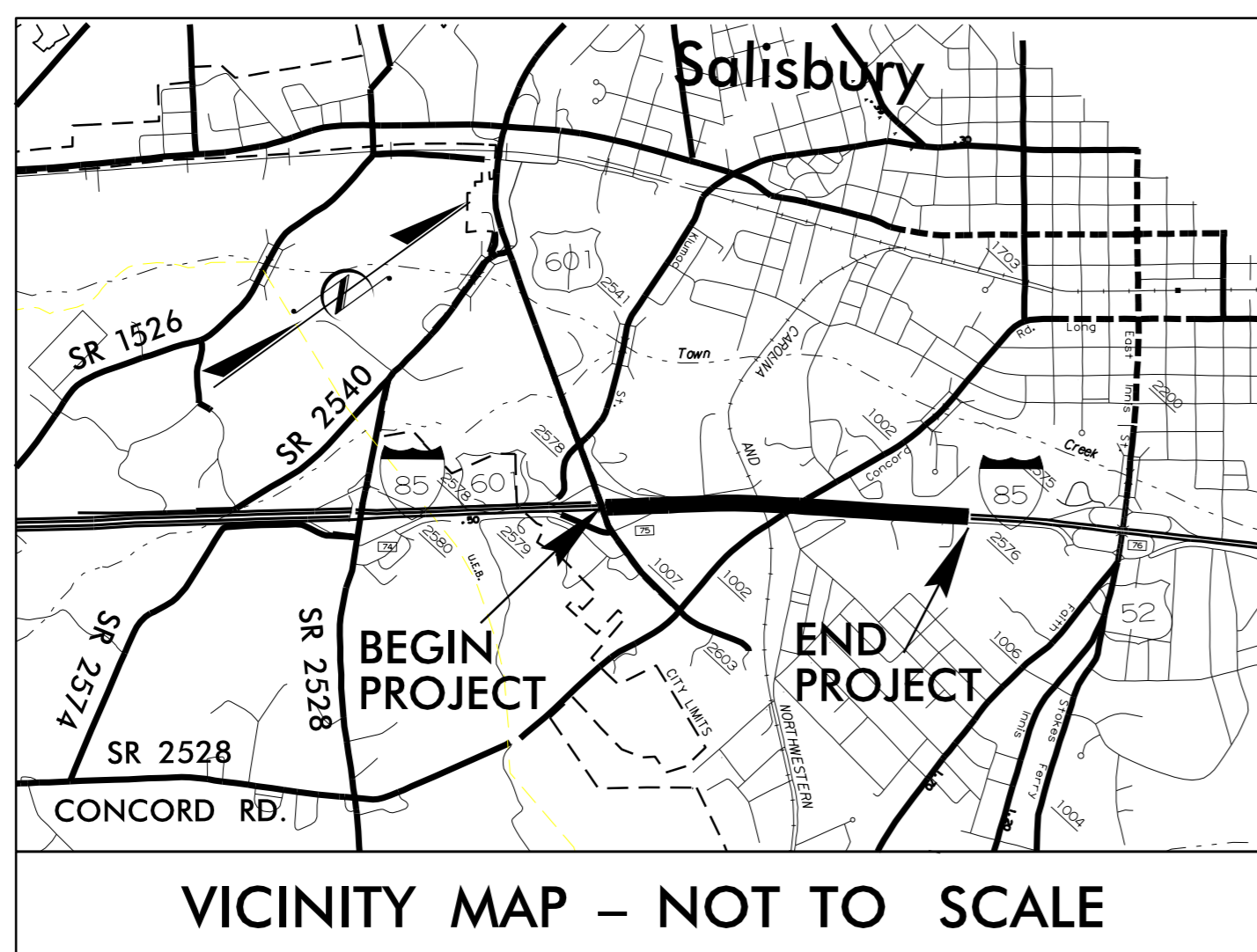

DOCUMENT NOT CONSIDERED FINAL
UNLESS ALL SIGNATURES COMPLETED

CONTRACT: C203853

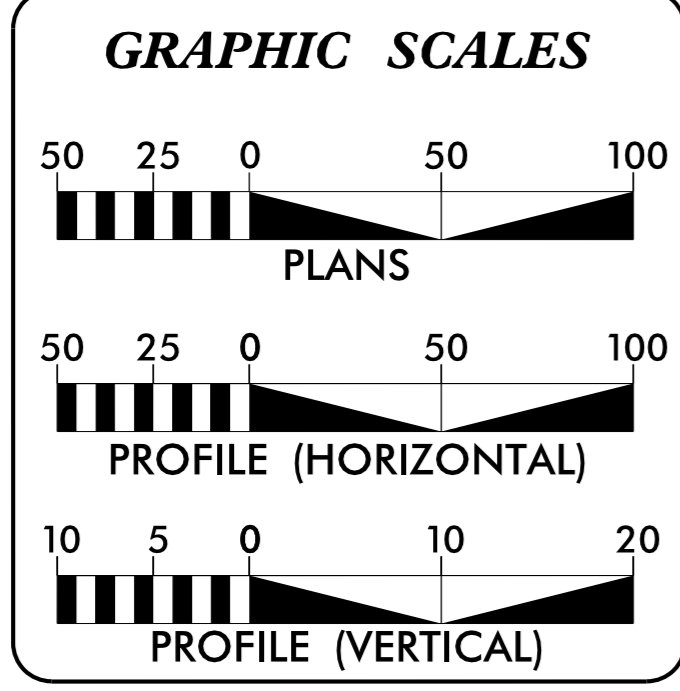

DESIGN DATA

ADT 2013 =	75000
DHV =	11 %
D =	55 %
T =	27 % *
V =	70 MPH
* TTST =	21 DUAL 6
FUNC CLASS =	INTERSTATE
STATEWIDE TIER	(REF. PROJECT I-2511CA)

PROJECT LENGTH

LENGTH ROADWAY TIP PROJECT I-5741 =	0.995 MILE
LENGTH STRUCTURE TIP PROJECT I-5741 =	0.082 MILE
TOTAL LENGTH TIP PROJECT I-5741 =	1.077 MILE

Prepared in the Office of:

DIVISION OF HIGHWAYS
1000 Birch Ridge Dr., Raleigh NC, 27610

2012 STANDARD SPECIFICATIONS	
RIGHT OF WAY DATE:	J. BRETT ABERNATHY, PE, PLS PROJECT ENGINEER
LETTING DATE:	WILLIAM A. BLANTON, PE, PLS PROJECT DESIGN ENGINEER
	MARCH 15, 2016

HYDRAULICS ENGINEER

DocuSigned by: *Galen Cail* 3/1/2016
SIGNATURE: _____ P.E.

ROADWAY DESIGN ENGINEER

DocuSigned by: *William A. Blanton* 3/1/2016
SIGNATURE: _____ P.E.

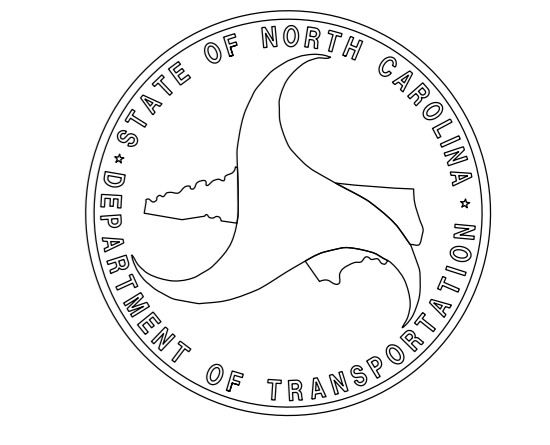

29-FEB-2016 14:30 S:\DDC\2015-18-T15505-185-Rowan\Plansheets\15505-ddc.tsh.dgn \$\$\$USERNAME\$\$\$

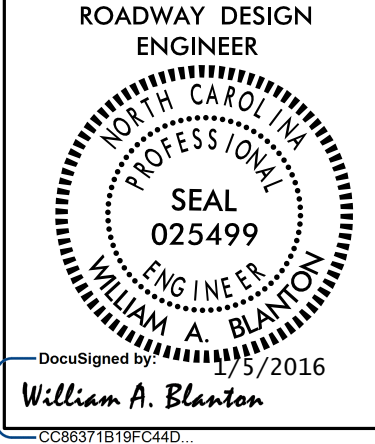

DOCUMENT NOT CONSIDERED FINAL
UNLESS ALL SIGNATURES COMPLETED

INDEX OF SHEETS

SHEET NUMBER	SHEET
1	TITLE SHEET
1A	INDEX OF SHEETS, GENERAL NOTES, AND STANDARD DRAWINGS
1B	CONVENTIONAL SYMBOLS
1C-1	SURVEY CONTROL SHEETS
1D-1	CENTERLINE COORDINATE LIST
2A-1	PAVEMENT SCHEDULE AND TYPICAL SECTIONS
2B-1	RESURFACING BRIDGE LIST
3B-1	ROADWAY SUMMARIES
3D-1	DRAINAGE SUMMARIES
4 THRU 6	PLAN SHEET
TMP-1 THRU TMP-10	TRAFFIC MANAGEMENT PLANS
1	STRUCTURE PLANS: TITLE SHEET
1A	STRUCTURE PLANS: INDEX OF SHEETS
S-1 THRU S-6	STRUCTURE PLANS
SN	STRUCTURE NOTES

GENERAL NOTES

GENERAL NOTES: 2012 SPECIFICATIONS
EFFECTIVE: 01-17-2012
REVISED: 10-31-2014

SUPERELEVATION:
ALL CURVES ON THIS PROJECT SHALL BE SUPERELEVATED IN ACCORDANCE WITH STD. NO. 225.05 USING THE RATE OF SUPERELEVATION AND RUNOFF SHOWN ON THE PLANS. SUPERELEVATION IS TO BE REVOLVED ABOUT THE GRADE POINTS SHOWN ON THE TYPICAL SECTIONS.

SHOULDER CONSTRUCTION:
ASPHALT, EARTH, AND CONCRETE SHOULDER CONSTRUCTION ON THE HIGH SIDE OF SUPERELEVATED CURVES SHALL BE IN ACCORDANCE WITH STD. NO. 560.02

SHOULDER DRAINS:
SHOULDER DRAINS SHALL BE CONSTRUCTED IN ACCORDANCE WITH STD. NO. 816.02 AND DETAILS IN PLANS AT LOCATIONS DIRECTED BY THE ENGINEER.

GUARDRAIL:
THE GUARDRAIL LOCATIONS SHOWN ON THE PLANS MAY BE ADJUSTED DURING CONSTRUCTION AS DIRECTED BY THE ENGINEER. THE CONTRACTOR SHOULD CONSULT WITH THE ENGINEER PRIOR TO ORDERING GUARDRAIL MATERIAL.

SUBSURFACE PLANS:
NO SUBSURFACE PLANS ARE AVAILABLE ON THIS PROJECT. THE CONTRACTOR SHOULD MAKE HIS OWN INVESTIGATION AS TO THE SUBSURFACE CONDITIONS.
ANY RELOCATION OF EXISTING UTILITIES WILL BE ACCOMPLISHED BY OTHERS.

2012 ROADWAY ENGLISH STANDARD DRAWINGS

2012 ROADWAY ENGLISH STANDARD DRAWINGS
EFF. 01-17-2012
REV. 10-30-2012

The following Roadway Standards as appear in "Roadway Standard Drawings" Highway Design Branch - N. C. Department of Transportation - Raleigh, N. C., Dated January, 2012 are applicable to this project and by reference hereby are considered a part of these plans:

STD.NO.	TITLE
DIVISION 2 - EARTHWORK	
225.01	Guide for Grading Subgrade - Interstate and Freeway
225.05	Method of Obtaining Superelevation - Divided Highways
DIVISION 3 - PIPE CULVERTS	
300.01	Method of Pipe Installation
DIVISION 5 - SUBGRADE, BASES AND SHOULDERS	
560.02	Method of Shoulder Construction - High Side of Superelevated Curve - Method II
DIVISION 7 - CONCRETE PAVEMENTS AND SHOULDERS	
700.01	Concrete Pavement Joints - Construction and Contraction Joints
700.02	Expansion Joint Layout - for Rigid Doweled Pavement at Bridges
700.03	Dowel Assembly
700.04	Concrete Pavement Header Board
700.05	Tying Proposed Pavement to Existing
710.01	Concrete Pavement - Station Marking
720.01	Concrete Shoulders - Stamped or Rolled Rumble Strips, Milled Rumble Strips
DIVISION 8 - INCIDENTALS	
816.01	Concrete Pads - for Shoulder Drain Installation
816.02	Aggregate Shoulder Drain
840.18	Concrete Grated Drop Inlet Type 'B' - 12" thru 36" Pipe
840.20	Frames and Wide Slot Flat Grates
840.25	Anchorage for Frames - Brick or Concrete or Precast
840.27	Brick Grated Drop Inlet Type 'B' - 12" thru 36" Pipe
846.04	Drop Inlet Installation in Shoulder Berm Gutter
862.01	Guardrail Placement
862.02	Guardrail Installation
866.02	Woven Wire Fence - with Wood Post
876.02	Guide for Rip Rap at Pipe Outlets

STATE OF NORTH CAROLINA, DIVISION OF HIGHWAYS

CONVENTIONAL PLAN SHEET SYMBOLS

Note: Not to Scale *S.U.E. = *Subsurface Utility Engineering*

04/05/15

BOUNDARIES AND PROPERTY:

State Line	-----
County Line	-----
Township Line	-----
City Line	-----
Reservation Line	-----
Property Line	-----
Existing Iron Pin	○ EIP
Property Corner	----->
Property Monument	□ EDM
Parcel/Sequence Number	⑫③
Existing Fence Line	-x-x-x-
Proposed Woven Wire Fence	○
Proposed Chain Link Fence	□
Proposed Barbed Wire Fence	◇
Existing Wetland Boundary	----- WLB
Proposed Wetland Boundary	----- WLB
Existing Endangered Animal Boundary	----- EAB
Existing Endangered Plant Boundary	----- EPB
Existing Historic Property Boundary	----- HPB
Known Contamination Area: Soil	-----
Potential Contamination Area: Soil	-----
Known Contamination Area: Water	-----
Potential Contamination Area: Water	-----
Contaminated Site: Known or Potential	☠ ?

BUILDINGS AND OTHER CULTURE:

Gas Pump Vent or U/G Tank Cap	○
Sign	○ S
Well	○ W
Small Mine	✕
Foundation	□
Area Outline	□
Cemetery	□ †
Building	□
School	□
Church	□
Dam	□

HYDROLOGY:

Stream or Body of Water	-----
Hydro, Pool or Reservoir	□
Jurisdictional Stream	----- JS
Buffer Zone 1	----- BZ 1
Buffer Zone 2	----- BZ 2
Flow Arrow	←
Disappearing Stream	----->
Spring	○
Wetland	-----
Proposed Lateral, Tail, Head Ditch	----- FLOW
False Sump	▽

RAILROADS:

Standard Gauge	-----
RR Signal Milepost	○ CSX TRANSPORTATION MILEPOST 35
Switch	□ SWITCH
RR Abandoned	-----
RR Dismantled	-----

RIGHT OF WAY:

Baseline Control Point	◆
Existing Right of Way Marker	△
Existing Right of Way Line	-----
Proposed Right of Way Line	----- RW
Proposed Right of Way Line with Iron Pin and Cap Marker	----- RW
Proposed Right of Way Line with Concrete or Granite R/W Marker	----- RW
Proposed Control of Access Line with Concrete CA Marker	----- CA
Existing Control of Access	----- CA
Proposed Control of Access	----- CA
Existing Easement Line	----- E
Proposed Temporary Construction Easement	----- E
Proposed Temporary Drainage Easement	----- TDE
Proposed Permanent Drainage Easement	----- PDE
Proposed Permanent Drainage / Utility Easement	----- DUE
Proposed Permanent Utility Easement	----- PUE
Proposed Temporary Utility Easement	----- TUE
Proposed Aerial Utility Easement	----- AUE
Proposed Permanent Easement with Iron Pin and Cap Marker	◆

ROADS AND RELATED FEATURES:

Existing Edge of Pavement	-----
Existing Curb	-----
Proposed Slope Stakes Cut	----- C
Proposed Slope Stakes Fill	----- F
Proposed Curb Ramp	----- CR
Existing Metal Guardrail	-----
Proposed Guardrail	-----
Existing Cable Guiderail	-----
Proposed Cable Guiderail	-----
Equality Symbol	⊕
Pavement Removal	▣

VEGETATION:

Single Tree	☼
Single Shrub	☼
Hedge	-----
Woods Line	-----

Orchard	☼ ☼ ☼ ☼
Vineyard	□ Vineyard

EXISTING STRUCTURES:

MAJOR:	
Bridge, Tunnel or Box Culvert	----- CONC
Bridge Wing Wall, Head Wall and End Wall	----- CONC WW
MINOR:	
Head and End Wall	----- CONC HW
Pipe Culvert	-----
Footbridge	-----
Drainage Box: Catch Basin, DI or JB	□ CB
Paved Ditch Gutter	-----
Storm Sewer Manhole	○ S
Storm Sewer	----- S

UTILITIES:

POWER:	
Existing Power Pole	●
Proposed Power Pole	○
Existing Joint Use Pole	●
Proposed Joint Use Pole	○
Power Manhole	⊕
Power Line Tower	⊠
Power Transformer	⊠
U/G Power Cable Hand Hole	●
H-Frame Pole	●
U/G Power Line LOS B (S.U.E.*)	----- P
U/G Power Line LOS C (S.U.E.*)	----- P
U/G Power Line LOS D (S.U.E.*)	----- P

TELEPHONE:

Existing Telephone Pole	●
Proposed Telephone Pole	○
Telephone Manhole	⊕
Telephone Pedestal	⊠
Telephone Cell Tower	⊠
U/G Telephone Cable Hand Hole	●
U/G Telephone Cable LOS B (S.U.E.*)	----- T
U/G Telephone Cable LOS C (S.U.E.*)	----- T
U/G Telephone Cable LOS D (S.U.E.*)	----- T
U/G Telephone Conduit LOS B (S.U.E.*)	----- TC
U/G Telephone Conduit LOS C (S.U.E.*)	----- TC
U/G Telephone Conduit LOS D (S.U.E.*)	----- TC
U/G Fiber Optics Cable LOS B (S.U.E.*)	----- T FO
U/G Fiber Optics Cable LOS C (S.U.E.*)	----- T FO
U/G Fiber Optics Cable LOS D (S.U.E.*)	----- T FO

WATER:

Water Manhole	⊕
Water Meter	○
Water Valve	⊗
Water Hydrant	⊕
U/G Water Line LOS B (S.U.E.*)	----- W
U/G Water Line LOS C (S.U.E.*)	----- W
U/G Water Line LOS D (S.U.E.*)	----- W
Above Ground Water Line	----- A/G Water

TV:

TV Pedestal	⊠
TV Tower	⊗
U/G TV Cable Hand Hole	⊠
U/G TV Cable LOS B (S.U.E.*)	----- TV
U/G TV Cable LOS C (S.U.E.*)	----- TV
U/G TV Cable LOS D (S.U.E.*)	----- TV
U/G Fiber Optic Cable LOS B (S.U.E.*)	----- TV FO
U/G Fiber Optic Cable LOS C (S.U.E.*)	----- TV FO
U/G Fiber Optic Cable LOS D (S.U.E.*)	----- TV FO

GAS:

Gas Valve	◇
Gas Meter	⊕
U/G Gas Line LOS B (S.U.E.*)	----- G
U/G Gas Line LOS C (S.U.E.*)	----- G
U/G Gas Line LOS D (S.U.E.*)	----- G
Above Ground Gas Line	----- A/G Gas

SANITARY SEWER:

Sanitary Sewer Manhole	⊕
Sanitary Sewer Cleanout	⊕
U/G Sanitary Sewer Line	----- SS
Above Ground Sanitary Sewer	----- A/G Sanitary Sewer
SS Forced Main Line LOS B (S.U.E.*)	----- FSS
SS Forced Main Line LOS C (S.U.E.*)	----- FSS
SS Forced Main Line LOS D (S.U.E.*)	----- FSS

MISCELLANEOUS:

Utility Pole	●
Utility Pole with Base	□
Utility Located Object	○
Utility Traffic Signal Box	⊠
Utility Unknown U/G Line LOS B (S.U.E.*)	----- ?UTL
U/G Tank; Water, Gas, Oil	□
Underground Storage Tank, Approx. Loc.	⊠ UST
A/G Tank; Water, Gas, Oil	□
Geoenvironmental Boring	⊕
U/G Test Hole LOS A (S.U.E.*)	⊕
Abandoned According to Utility Records	AATUR
End of Information	E.O.I.

DOCUMENT NOT CONSIDERED FINAL
UNLESS ALL SIGNATURES COMPLETED

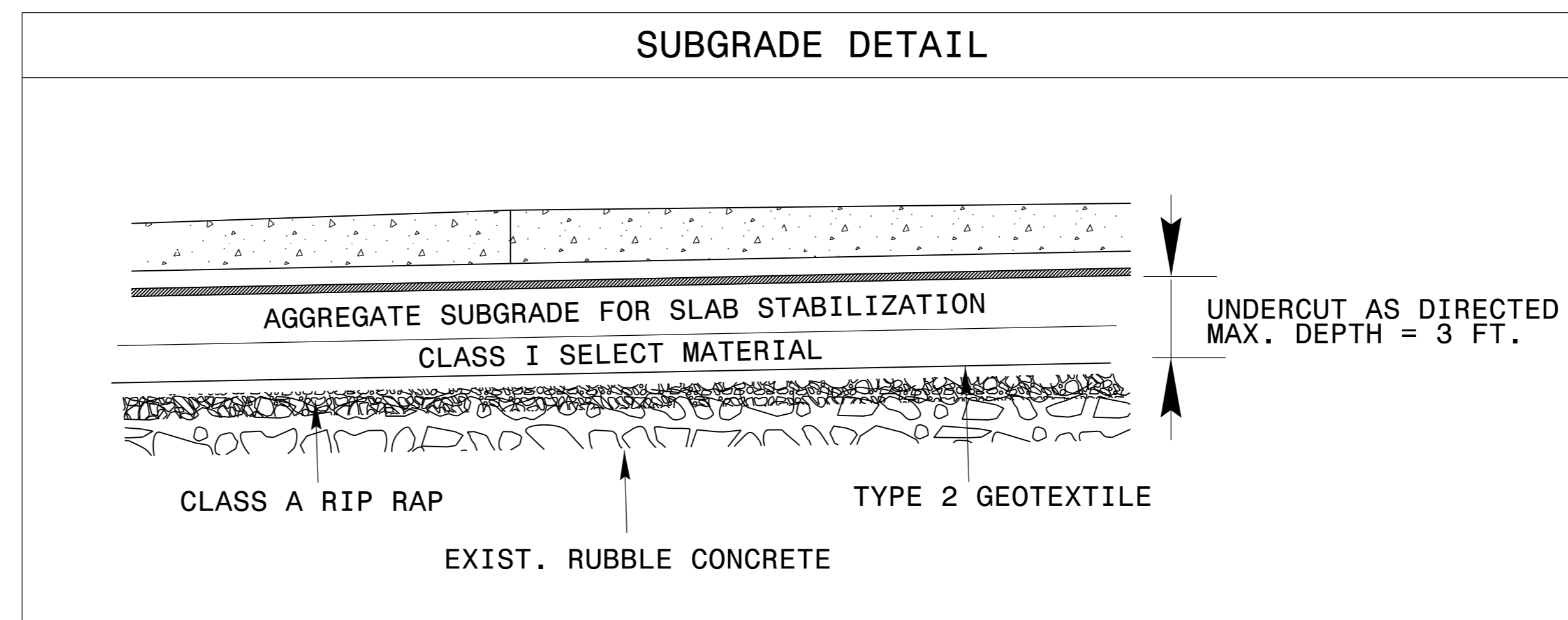
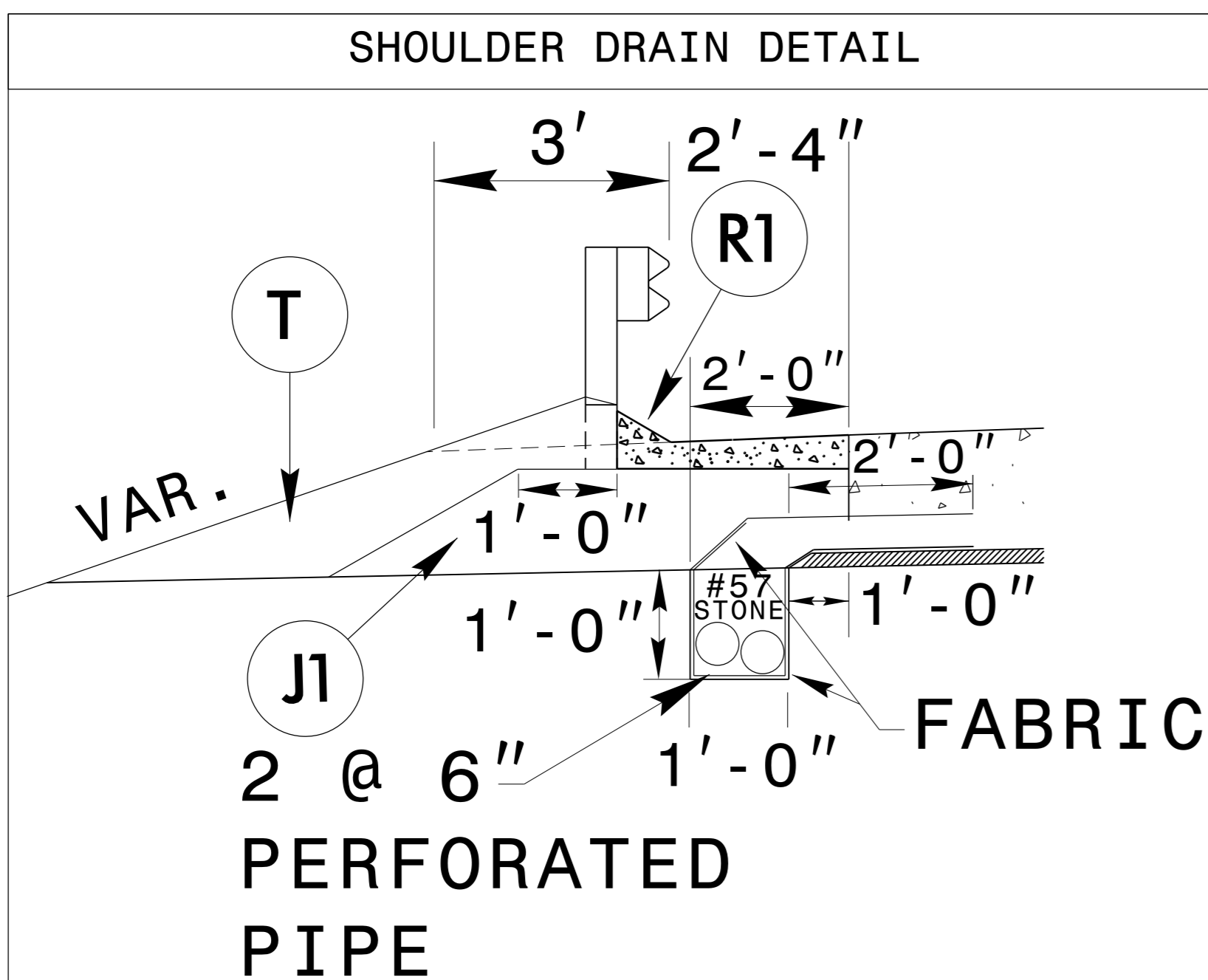
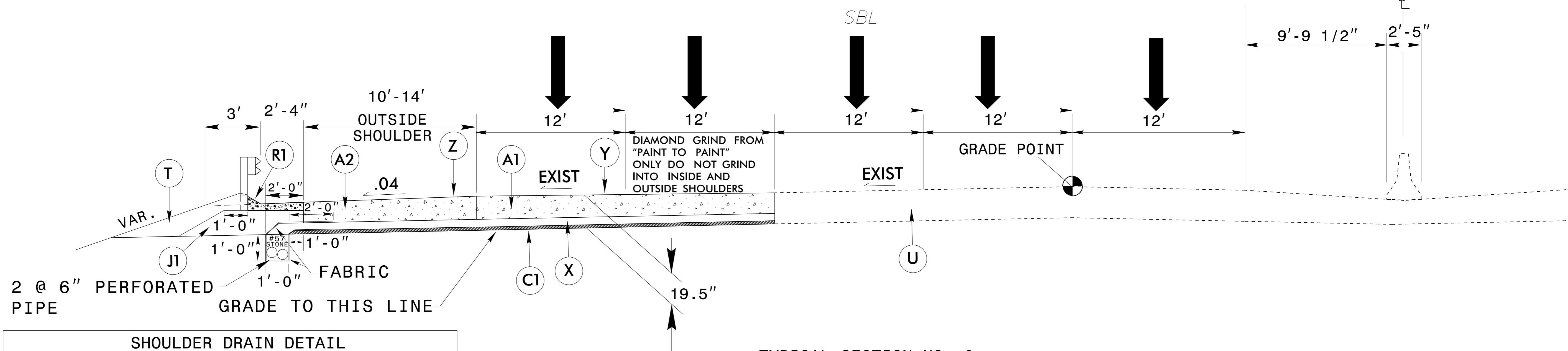
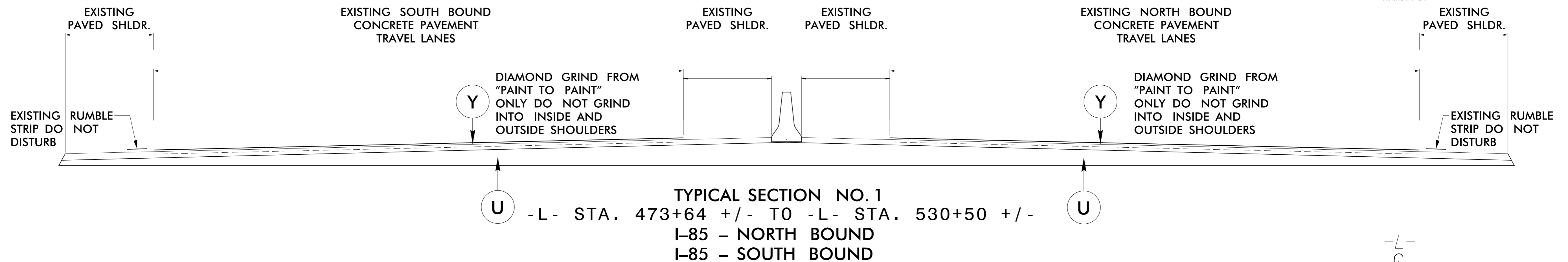

PAVEMENT SCHEDULE

A1	14" DOWELED JOINTED PORTLAND CEMENT CONCRETE PAVEMENT
A2	14" UN-DOWELED JOINTED PORTLAND CEMENT CONCRETE PAVEMENT
C1	PROP. APPROX. 1.5" ASPHALT CONCRETE SURFACE COURSE TYPE SF9.5A AT AN AVERAGE RATE OF 165 LBS. PER SQ. YD.
J1	PROP. VAR. DEPTH AGGREGATE BASE COURSE.
R1	SHOULDER BERM GUTTER.
T	EARTH MATERIAL.
U	EXISTING PAVEMENT
X	4" PERMEABLE ASPHALT DRAINAGE COURSE (PADC), TYPE P-57
Y	PROPOSED DIAMOND GRINDING
Z	RUMBLE STRIPS.

NOTE: PAV. EDGES ARE 1:1 UNLESS SHOWN OTHERWISE.

6/2/09
25-FEB-2016 14:45
S:\DC\2015-16-1\1506\15063308
Blanton\Geotech\RevisedTypical\160229\15505_geo_typ.dgn

PROJECT REFERENCE NO. 1-5505	SHEET NO. 5
RW SHEET NO.	
ROADWAY DESIGN ENGINEER WILLIAM A. BLANTON PROFESSIONAL SEAL 025499 1/5/2016	HYDRAULICS ENGINEER GALIN LAIL PROFESSIONAL SEAL 022000 1/7/2016
DocuSigned by: William A. Blanton	DocuSigned by: Galun Lail

DOCUMENT NOT CONSIDERED FINAL
UNLESS ALL SIGNATURES COMPLETED

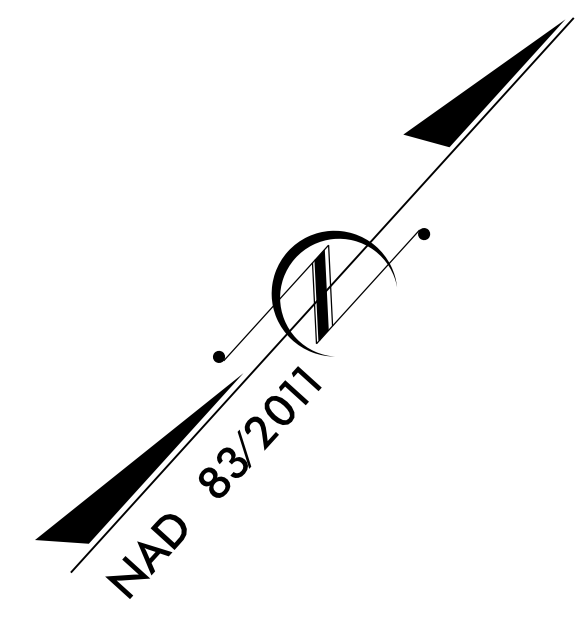

APPROXIMATE AREA OF PAVEMENT REPAIR.
ACTUAL AREA OF REPAIR TO BE DETERMINED
BY FIELD ENGINEER.

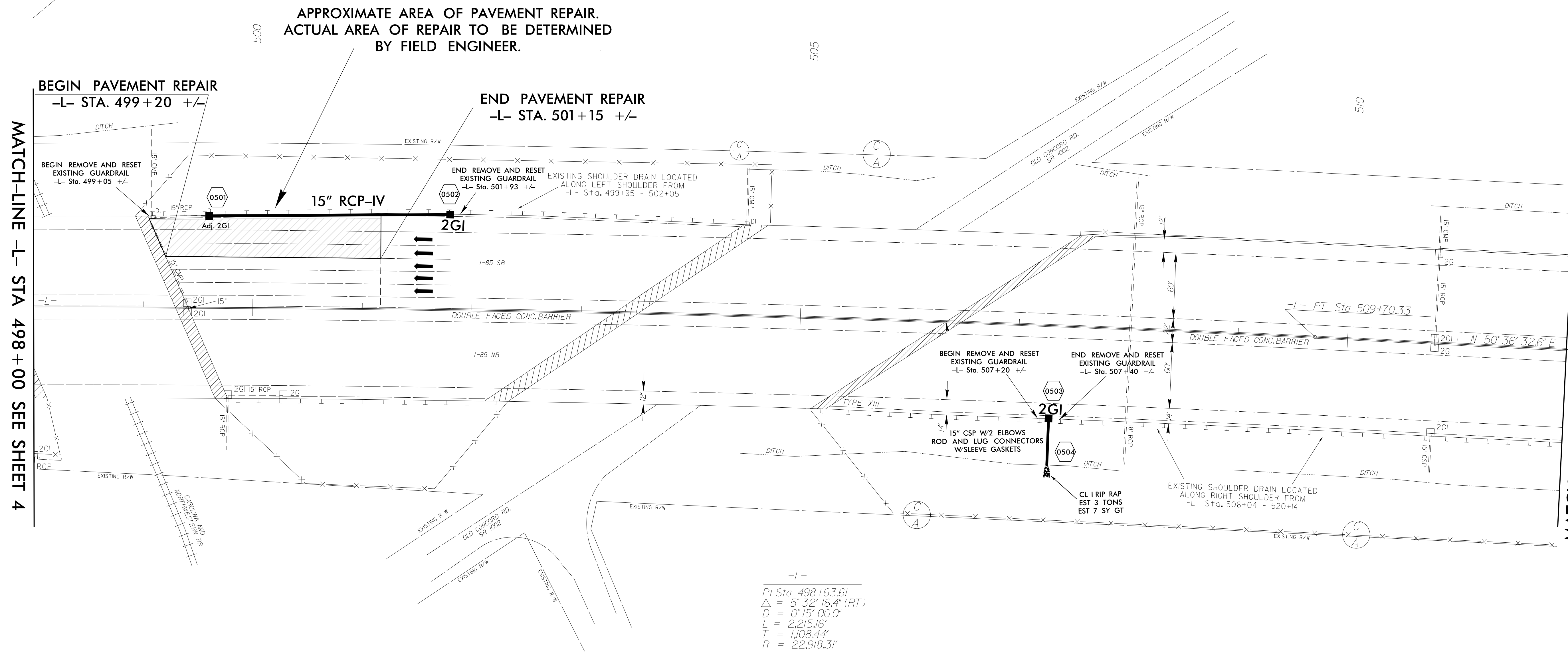

-L-
PI Sta. 498+63.61
Δ = 5° 32' 16.4" (RT)
D = 0° 15' 00.0"
L = 2,215.16'
T = 1,108.44'
R = 22,918.31'

MATCH-LINE -L- STA 498 + 00 SEE SHEET 4

MATCH-LINE -L- STA 512 + 00 SEE SHEET 6

REVISIONS

8/17/99

23-DEC-2016 14:57 I:\5505-1 85-Rovam\Plansheets\15505-ddc-ps15.dgn

PROJECT REFERENCE NO. 1-5741	SHEET NO. 6
RW SHEET NO.	
ROADWAY DESIGN ENGINEER WILLIAM A. BLANTON SEAL 025499 1/5/2016	HYDRAULICS ENGINEER GLEN LAIL SEAL 022000 1/7/2016
DocuSigned by: William A. Blanton	DocuSigned by: Glen Lail

DOCUMENT NOT CONSIDERED FINAL
UNLESS ALL SIGNATURES COMPLETED

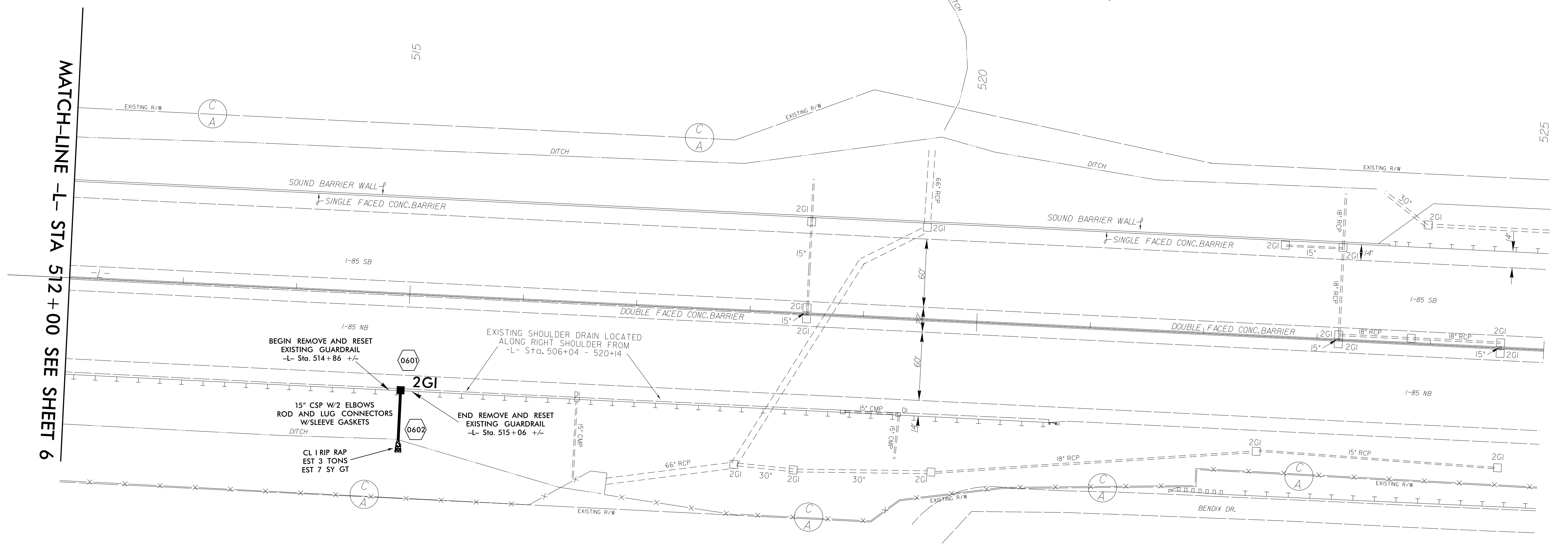
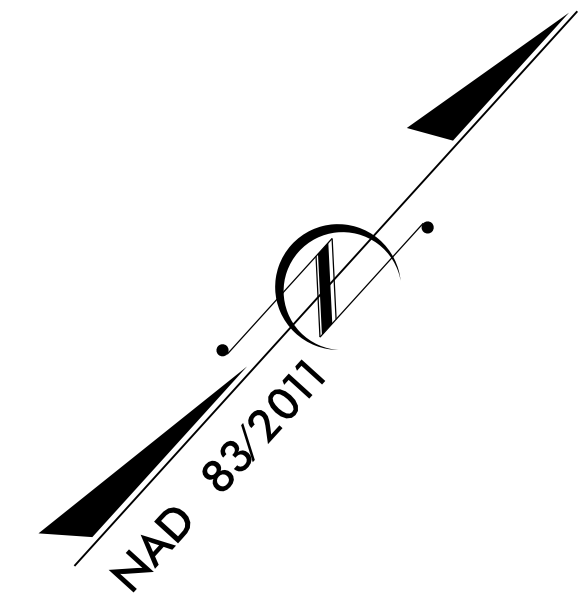

MATCH-LINE -L- STA 512+00 SEE SHEET 6

BEGIN REMOVE AND RESET EXISTING GUARDRAIL
-L- Sta. 514+86 +/-

15" CSP W/2 ELBOWS ROD AND LUG CONNECTORS W/SLEEVE GASKETS

CL 1 RIP RAP EST 3 TONS EST 7 SY GT

EXISTING SHOULDER DRAIN LOCATED ALONG RIGHT SHOULDER FROM
-L- Sta. 506+04 - 520+14

END REMOVE AND RESET EXISTING GUARDRAIL
-L- Sta. 515+06 +/-

-L-

PI Sta 498+63.61
 $\Delta = 5' 32'' 16.4''$ (RT)
 $D = 0' 15'' 00.0''$
 $L = 2,215.16'$
 $T = 1,108.44'$
 $R = 22,918.31'$

REVISIONS

8/17/99

23-DEC-2016 14:57 I:\5505-1 85-Rovam\Plansheets\15505-dbc-ps16.dgn