

**This electronic collection of documents is provided
for the convenience of the user
and is Not a Certified Document –**

**The documents contained herein were originally issued
and sealed by the individuals whose names and license
numbers appear on each page, on the dates appearing
with their signature on that page.**

**This file or an individual page
shall not be considered a certified document.**

STATE OF NORTH CAROLINA
DEPARTMENT OF TRANSPORTATION

PAVEMENT MARKING PLAN
HARNETT COUNTY

LOCATION: I-95 FROM MILE MARKER 53 TO MILE MARKER 78, JOHNSTON /HARNETT COUNTY LINE (REHABILITATION).

TIP NO. I-5788	SHEET NO. PMP-1
APPROVED: <i>Ayman Alqudwah</i> F32AC5CAF95472	
DATE: 12/8/2015	
SEAL	

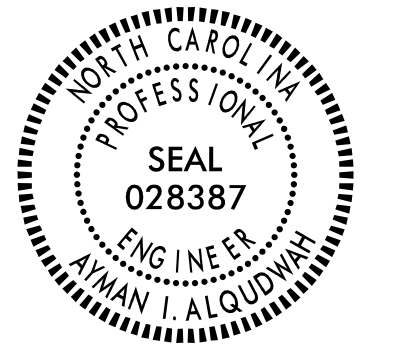

T.I.P.: I-5788

CONTRACT:

I-5788 FINAL PAVEMENT MARKING SCHEDULE

SYMBOL	(FINAL PAVEMENT MARKINGS)
	THERMOPLASTIC (24", 120 MILS)
T2	WHITE STOPBAR THERMOPLASTIC (12", 90 MILS)
TU	WHITE DIAGONAL THERMOPLASTIC (4", 120 MILS)
T8	2 FT. - 6 FT./SP WHITE MINSKIP
TI	YELLOW DOUBLE CENTER THERMOPLASTIC (6", 90 MILS)
T6	WHITE EDGELINE
T7	YELLOW EDGELINE THERMOPLASTIC (6", 120 MILS)
TJ	10 FT. WHITE SKIP
TK	3 FT. - 9 FT./SP WHITE MINSKIP
TL	WHITE SOLID LANE LINE THERMOPLASTIC (12", 90 MILS)
TS	WHITE GORELINE THERMOPLASTIC (12", 120 MILS)
T14	3 FT. - 9 FT./SP WHITE MINSKIP POLYUREA (6", HIGHLY REFLECTIVE ELEMENTS)
V6	WHITE EDGELINE
V7	YELLOW EDGELINE
VJ	10 FT. WHITE SKIP THERMOPLASTIC PAVEMENT MARKING SYMBOLS (90 MILS)
UA	LEFT TURN ARROW
UB	RIGHT TURN ARROW
UD	COMBO LEFT/STRAIGHT ARROW
UE	COMBO RIGHT/STRAIGHT ARROW
UF	COMBO LEFT/RIGHT ARROW
UG	COMBO LEFT/RIGHT/STRAIGHT ARROW
UP	MERGE ARROW
UQ	RAMP ARROW SYMBOL THERMOPLASTIC PAVEMENT MARKING CHARACTER (120 MILS)
UI	ALPHANUMERIC CHAR. (MARKERS) SNOWPLOWABLE RAISED PAVEMENT MARKERS
ME	YELLOW & YELLOW
MF	CRYSTAL & RED

ROADWAY STANDARD DRAWING

THE FOLLOWING ROADWAY STANDARDS AS APPEAR IN "ROADWAY STANDARD DRAWINGS" - PROJECT SERVICES UNIT - N.C. DEPARTMENT OF TRANSPORTATION - RALEIGH, N.C., DATED JANUARY 2012 ARE APPLICABLE TO THIS PROJECT AND BY REFERENCE HEREBY ARE CONSIDERED A PART OF THESE PLANS:

STD. NO.	TITLE
1205.01	PAVEMENT MARKINGS - LINE TYPES AND OFFSETS
1205.02	PAVEMENT MARKINGS - TWO-LANE AND MULTILANE ROADWAYS
1205.03	PAVEMENT MARKINGS - EXIT AND ENTRANCE RAMPS
1205.04	PAVEMENT MARKINGS - INTERSECTIONS
1205.05	PAVEMENT MARKINGS - TURN LANES
1205.06	PAVEMENT MARKINGS - LANE DROPS
1205.08	PAVEMENT MARKINGS - SYMBOLS AND WORD MESSAGES
1205.09	PAVEMENT MARKINGS - PAINTED ISLANDS
1205.12	PAVEMENT MARKINGS - BRIDGES
1205.13	PAVEMENT MARKINGS - LANE REDUCTIONS
1250.01	RAISED PAVEMENT MARKERS - INSTALLATION SPACING
1253.01	RAISED PAVEMENT MARKERS - SNOWPLOWABLE
1261.01	GUARDRAIL AND BARRIER DELINEATORS - INSTALLATION SPACING
1261.02	GUARDRAIL AND BARRIER DELINEATORS - TYPES AND MOUNTING
1262.01	GUARDRAIL END DELINEATION

GENERAL NOTES

THE FOLLOWING GENERAL NOTES APPLY AT ALL TIMES FOR THE DURATION OF THE CONSTRUCTION PROJECT, EXCEPT WHEN OTHERWISE NOTED IN THE PLAN, OR DIRECTED BY THE ENGINEER.

- A) INSTALL PAVEMENT MARKINGS AND PAVEMENT MARKERS ON THE FINAL SURFACE AS FOLLOWS:
- | ROAD NAME | MARKING | MARKER |
|----------------|--|--------------|
| I-95 -L- | THERMOPLASTIC | SNOWPLOWABLE |
| I-95 -RAMPS- | THERMOPLASTIC | SNOWPLOWABLE |
| I-95 -BRIDGES- | POLYUREA W/ HIGHLY REFLECTIVE ELEMENTS | SNOWPLOWABLE |
- B) TIE PROPOSED PAVEMENT MARKING LINES TO EXISTING PAVEMENT MARKING LINES.
C) REMOVE/REPLACE ANY CONFLICTING/DAMAGED PAVEMENT MARKINGS AND MARKERS.
D) STOP BAR LOCATION AT NON-SIGNALIZED INTERSECTIONS MAY BE ADJUSTED AS DIRECTED BY THE ENGINEER.
E) UNLESS OTHERWISE SPECIFIED, HEATED-IN-PLACE THERMOPLASTIC MAY BE USED IN LIEU OF EXTRUDED THERMOPLASTIC FOR STOP BARS, SYMBOLS, CHARACTERS AND DIAGONALS. IF HEATED-IN-PLACE IS USED, IT SHALL BE PAID FOR USING THE EXTRUDED THERMOPLASTIC PAY ITEM.
F) REMOVE ALL RESIDUE AND SURFACE LAITANCE BY ACCEPTABLE METHODS ON CONCRETE BRIDGE DECKS PRIOR TO PLACING POLYUREA PAVEMENT MARKING MATERIAL.
G) PAVEMENT MARKING SHOULD END AT RESURFACING LIMITS ON RAMPS.

PLAN PREPARED BY: N.C.D.O.T. SIGNING AND DELINEATION UNIT

AYMAN ALQUDWAH, PE, CPM SIGNING & DELINEATION REGIONAL ENGINEER
BASIR A. RASHID SIGNING & DELINEATION PROJECT DESIGN ENGINEER

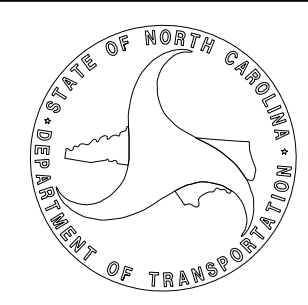

INDEX

SHEET NO.	DESCRIPTION
PMP-1	PAVEMENT MARKING PLAN TITLE AND SCHEDULE SHEET
PMP-2-25	PAVEMENT MARKING DETAIL

TIP NO. I-5788	SHEET NO. PMP-2
APPROVED: <i>Ayman Alqudwah</i> <small>DESIGNED BY: F32ACSCAF066472</small>	
DATE: 12/8/2015	
SEAL	

BEGIN MARKING PROJECT I-5788
(MILE MARKER 53)
STA. 685+10(±)
TIE TO I-5731 MARKINGS

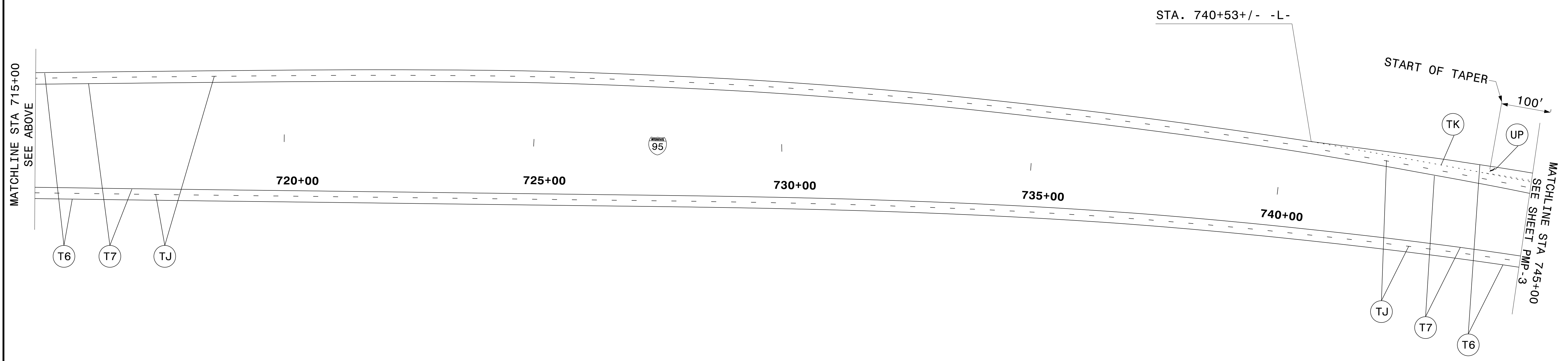
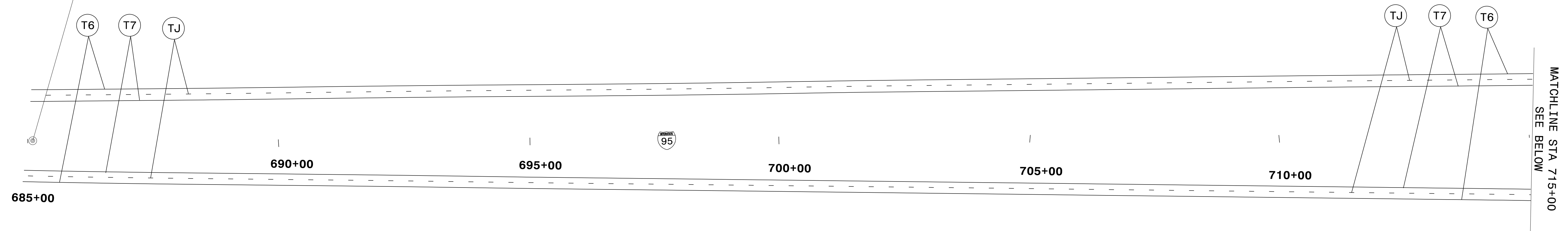
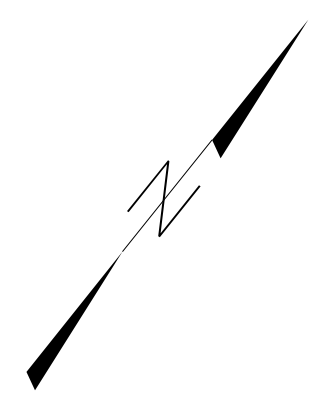
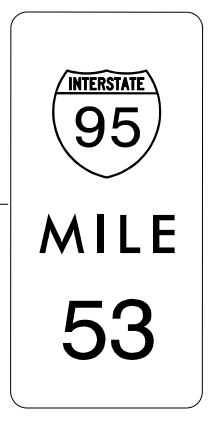

PAVEMENT MARKING DETAIL

TIP NO. I-5788	SHEET NO. PMP-3
APPROVED: <i>Ayman Alqudwah</i> <small>Disciplined by: F32ACSCAF066472</small>	
DATE: 12/8/2015	
SEAL	

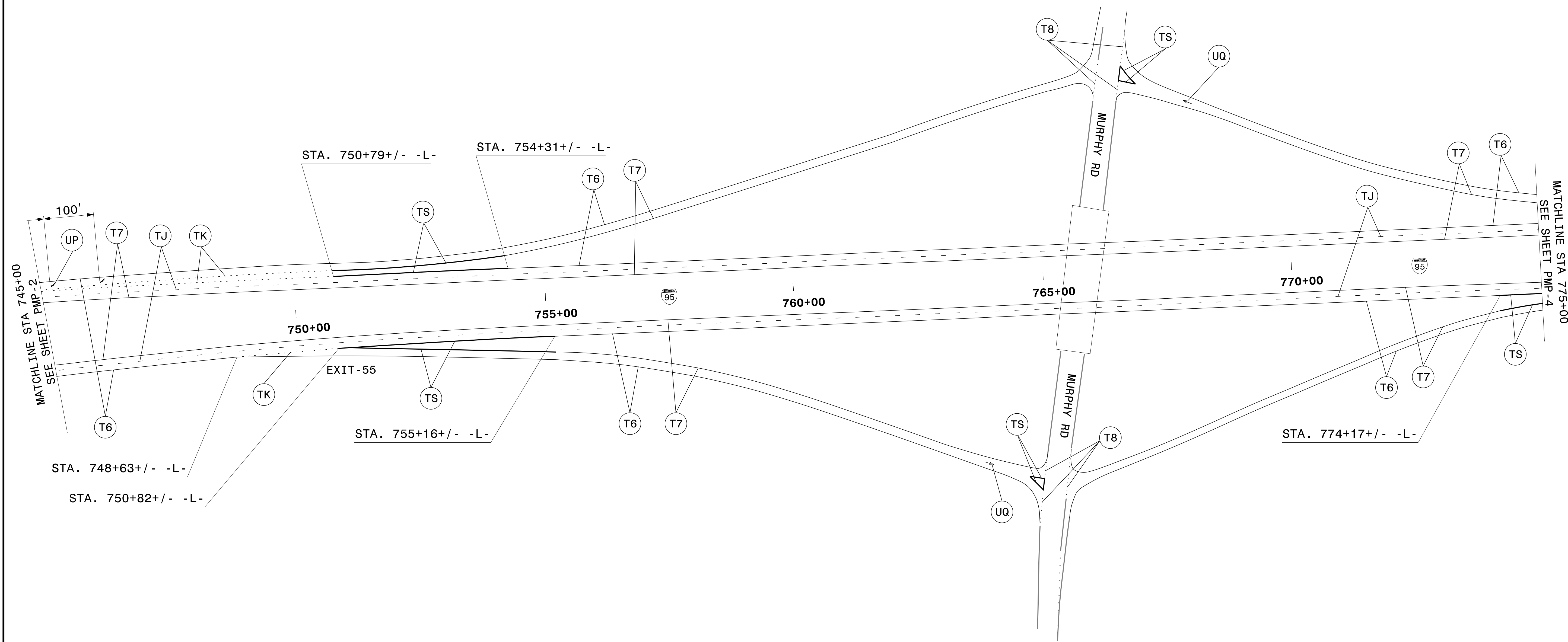
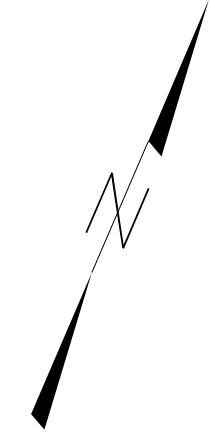

PAVEMENT MARKING DETAIL

TIP NO. I-5788	SHEET NO. PMP-4
Designed by: <i>Ayman Alqudwah</i>	
APPROVED: <i>Ayman Alqudwah</i> F32ACSCAF065472	
DATE: 12/8/2015	
SEAL	

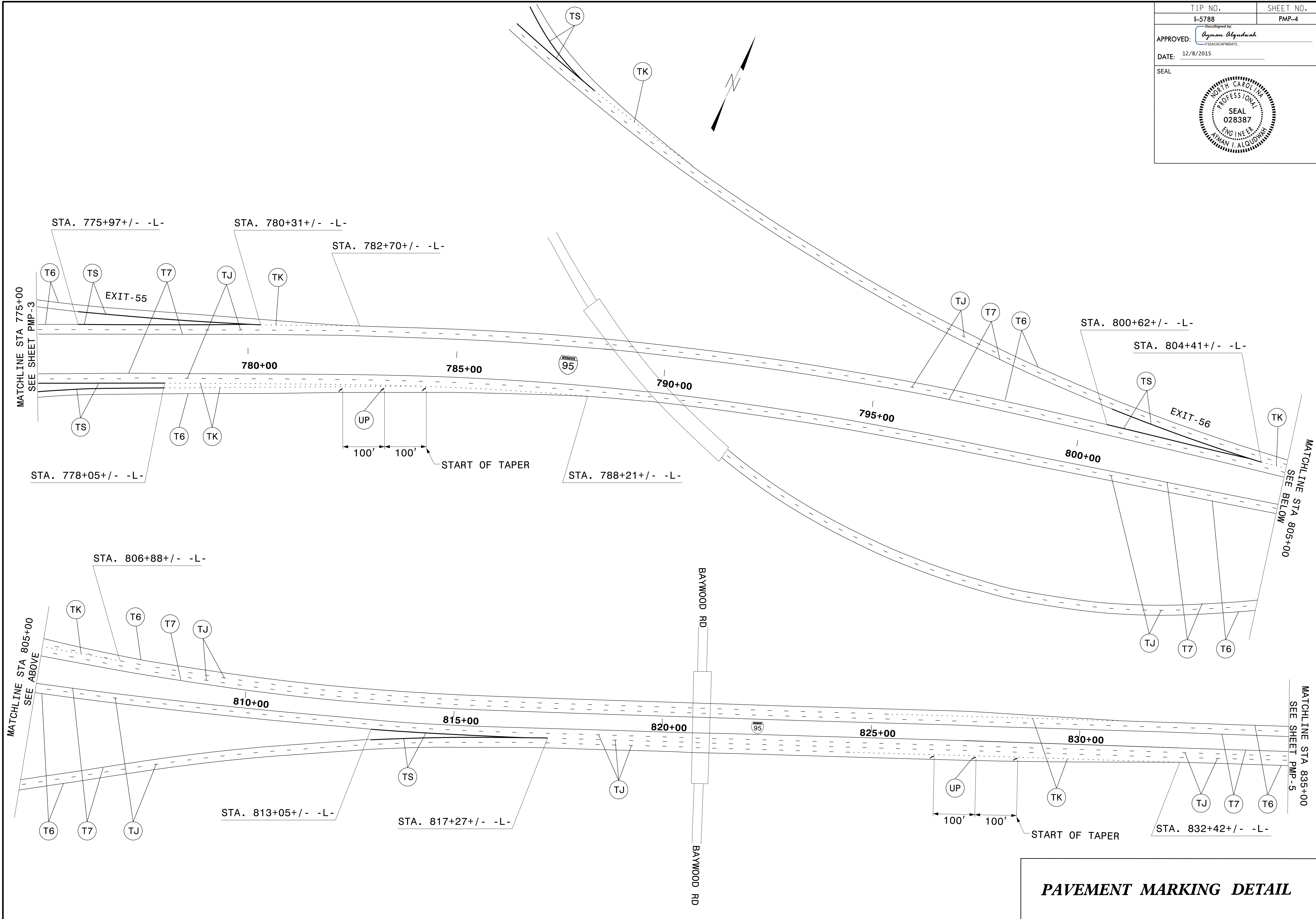

PAVEMENT MARKING DETAIL

TIP NO. I-5788	SHEET NO. PMP-5
APPROVED: <i>Ayman Alqudwah</i> <small>DESIGNED BY: F32ACSCAF066472</small>	
DATE: 12/8/2015	
SEAL	

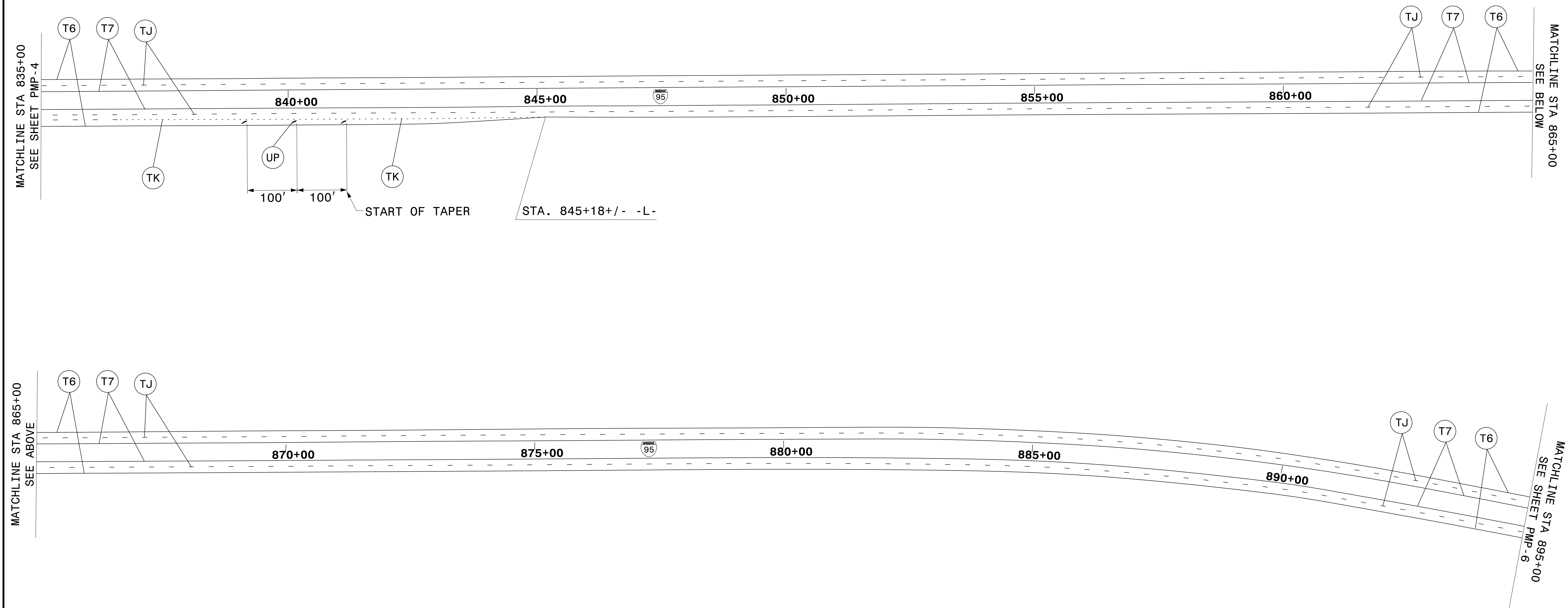
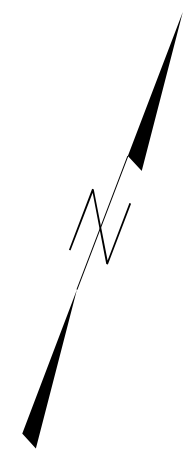

PAVEMENT MARKING DETAIL

TIP NO. I-5788	SHEET NO. PMP-6
APPROVED: <i>Ayman Alqudwah</i> F32ACSCAF066472	
DATE: 12/8/2015	
SEAL	

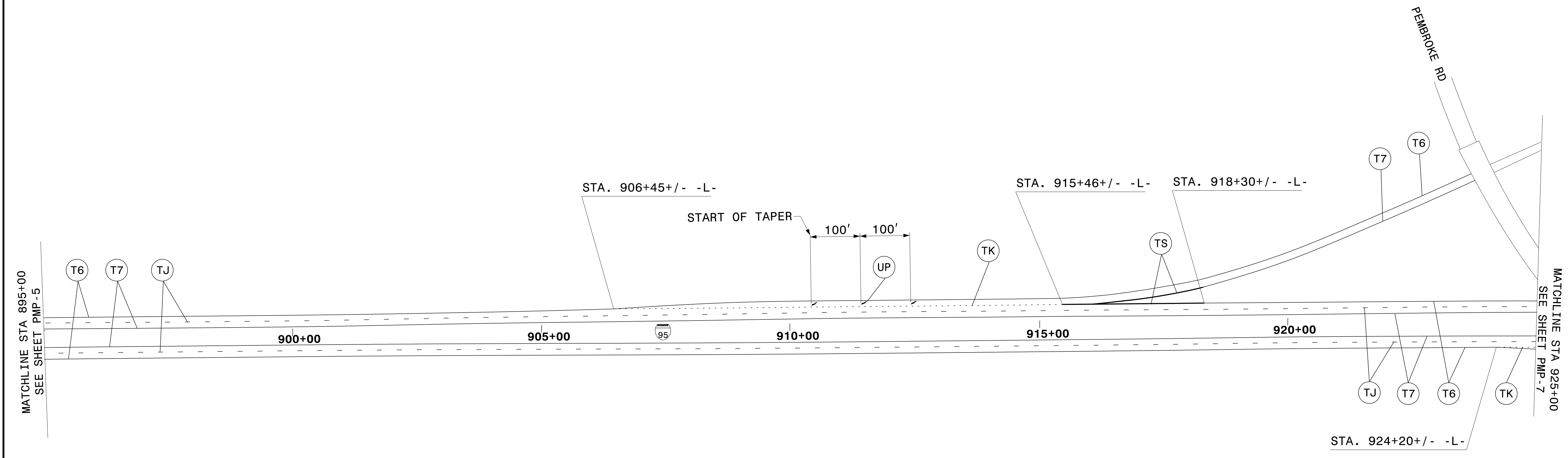
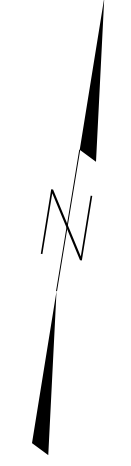

PAVEMENT MARKING DETAIL

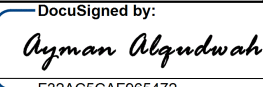
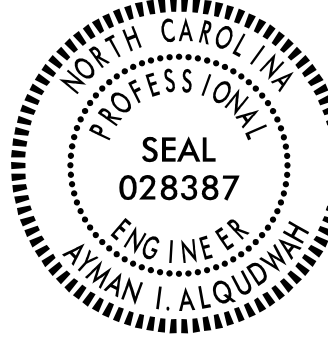
TIP NO. I-5788	SHEET NO. PMP-7
Approved by:  F32ACSCAF065472	
DATE: 12/8/2015	
SEAL 	

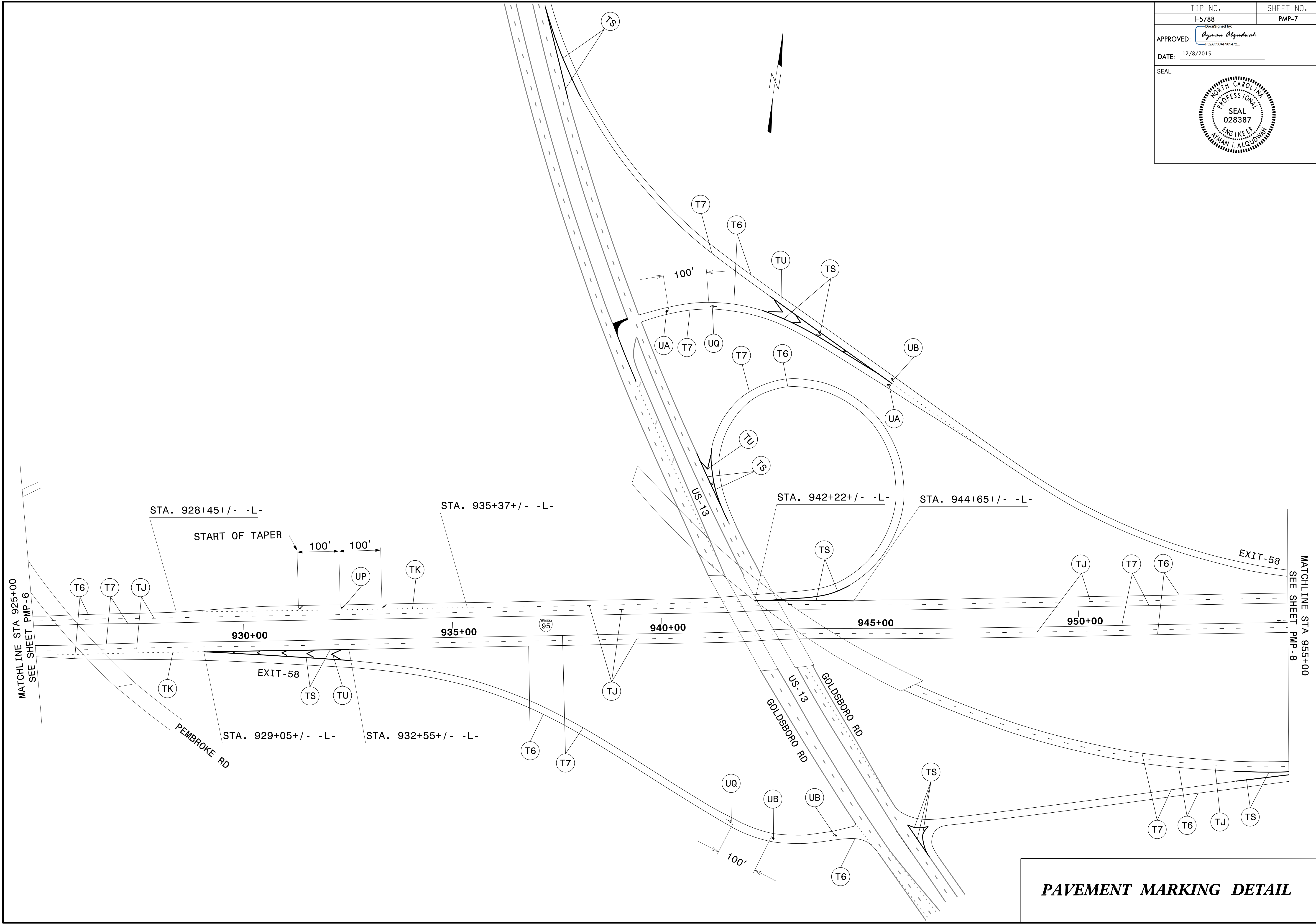

PAVEMENT MARKING DETAIL

TIP NO. I-5788	SHEET NO. PMP-8
APPROVED: <i>Ayman Alqudwah</i> <small>DESIGNED BY: F32ACSCAF066472</small>	
DATE: 12/8/2015	
SEAL	

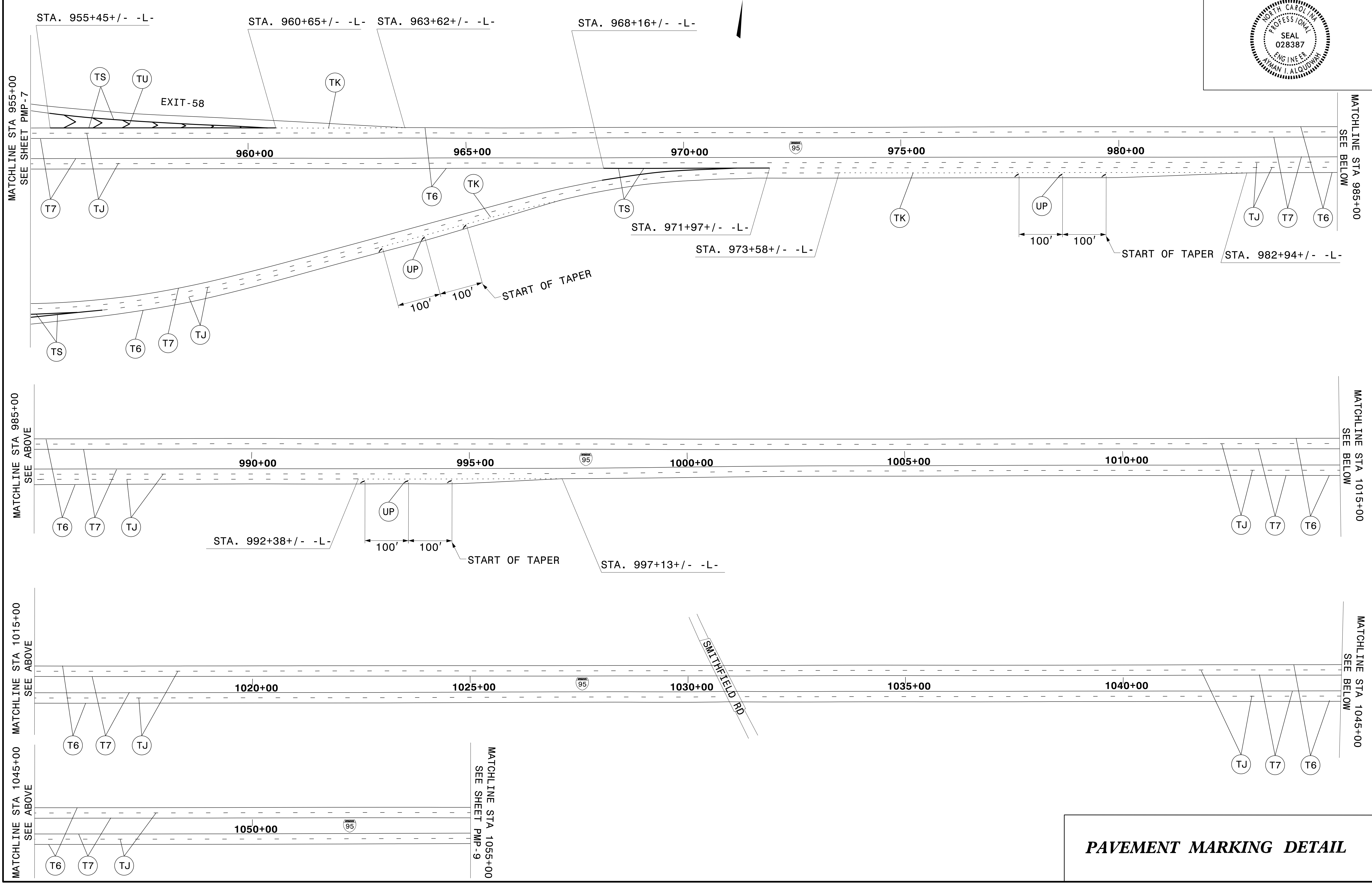

PAVEMENT MARKING DETAIL

TIP NO. I-5788	SHEET NO. PMP-9
APPROVED: <i>Ayman Alqudwah</i> <small>DESIGNED BY: F32ACSCAF066472</small>	
DATE: 12/8/2015	
SEAL	

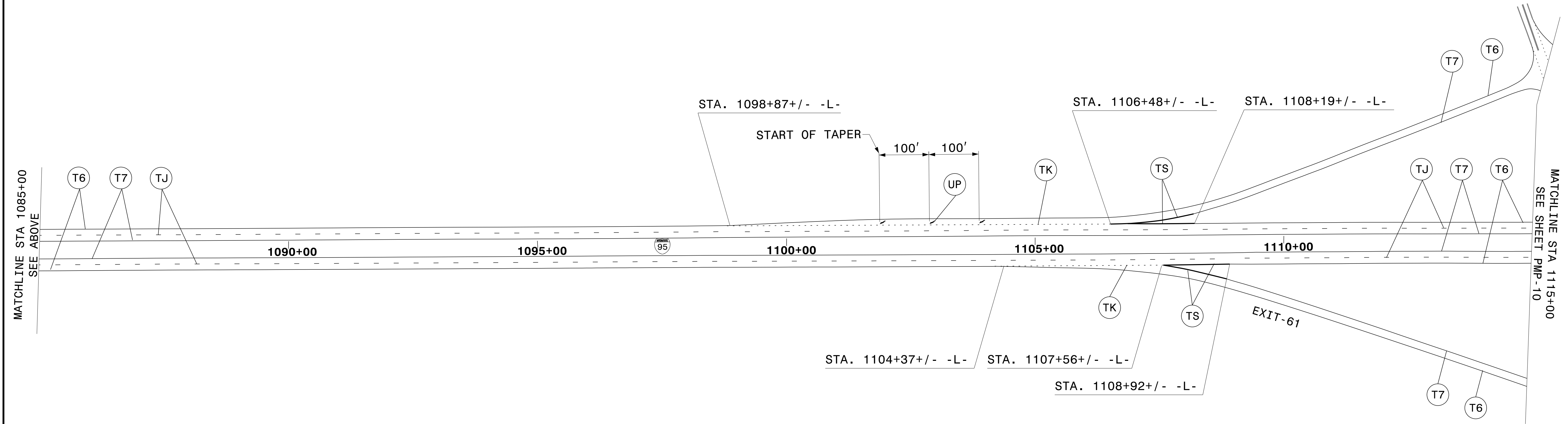
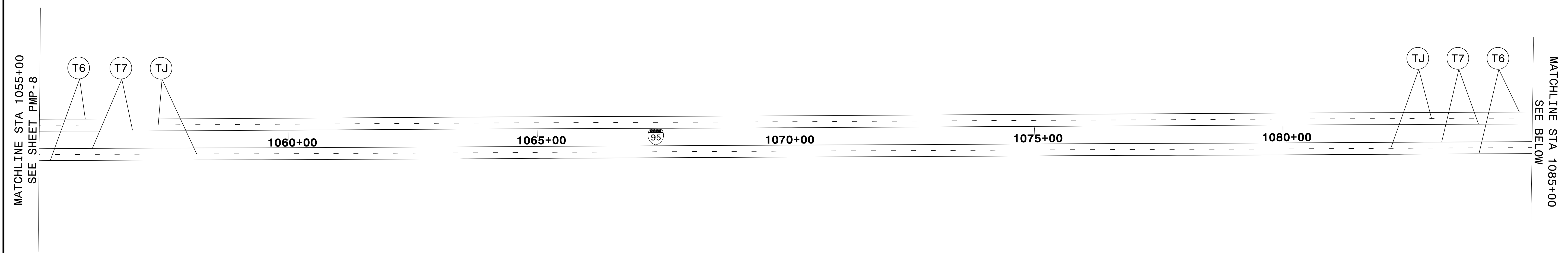
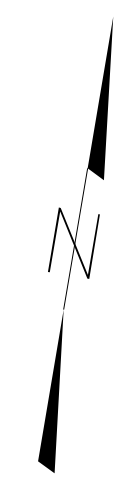

PAVEMENT MARKING DETAIL

TIP NO. I-5788	SHEET NO. PMP-10
APPROVED: <i>Ayman Alqudwah</i> <small>DESIGNED BY: F32ACSCAF065472</small>	
DATE: 12/8/2015	
SEAL	

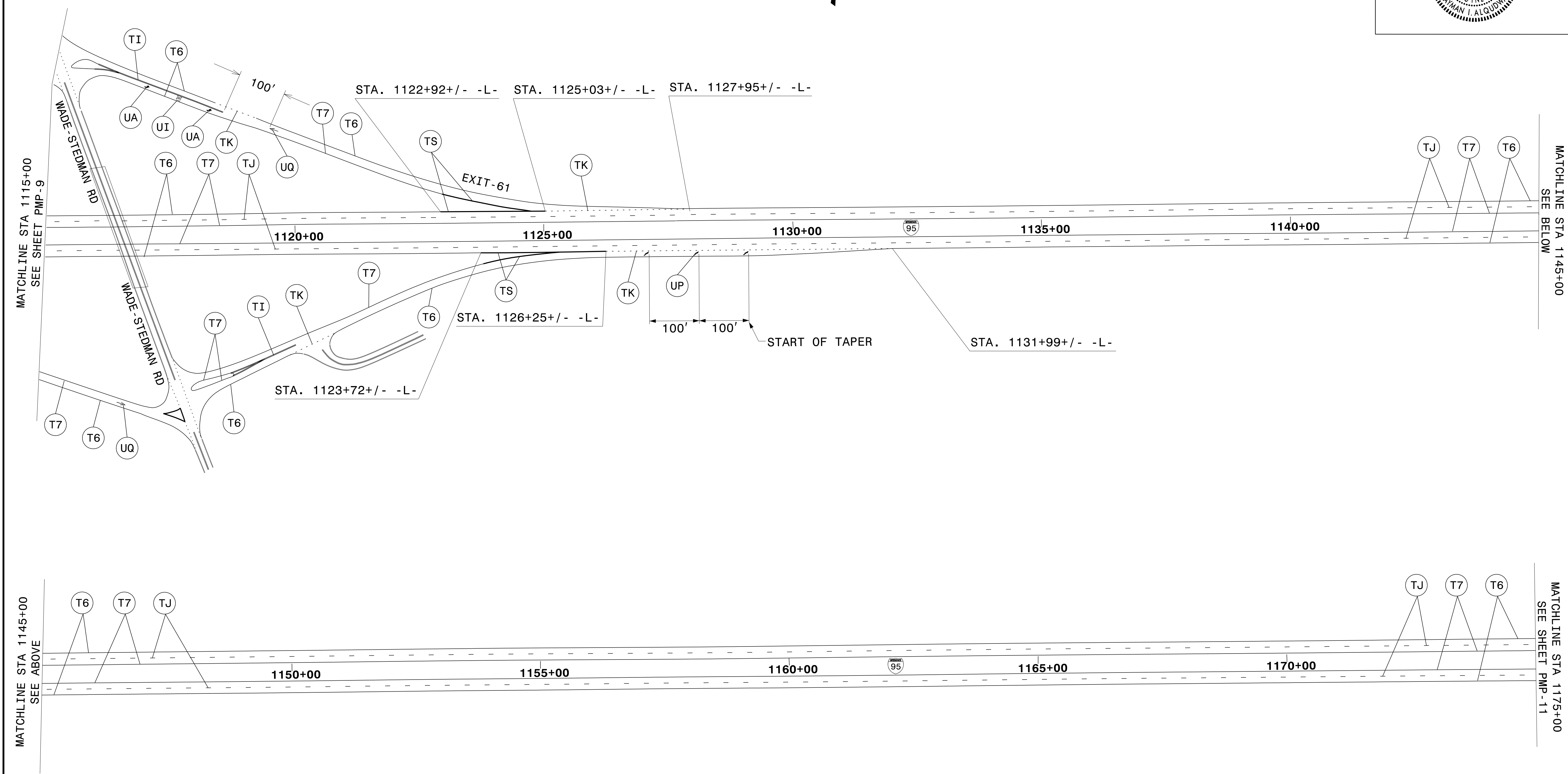
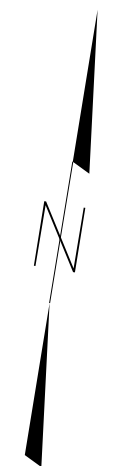

PAVEMENT MARKING DETAIL

TIP NO. I-5788	SHEET NO. PMP-11
APPROVED: <i>Ayman Alqudwah</i> <small>F32ACSCAF066472</small>	
DATE: 12/8/2015	
SEAL	

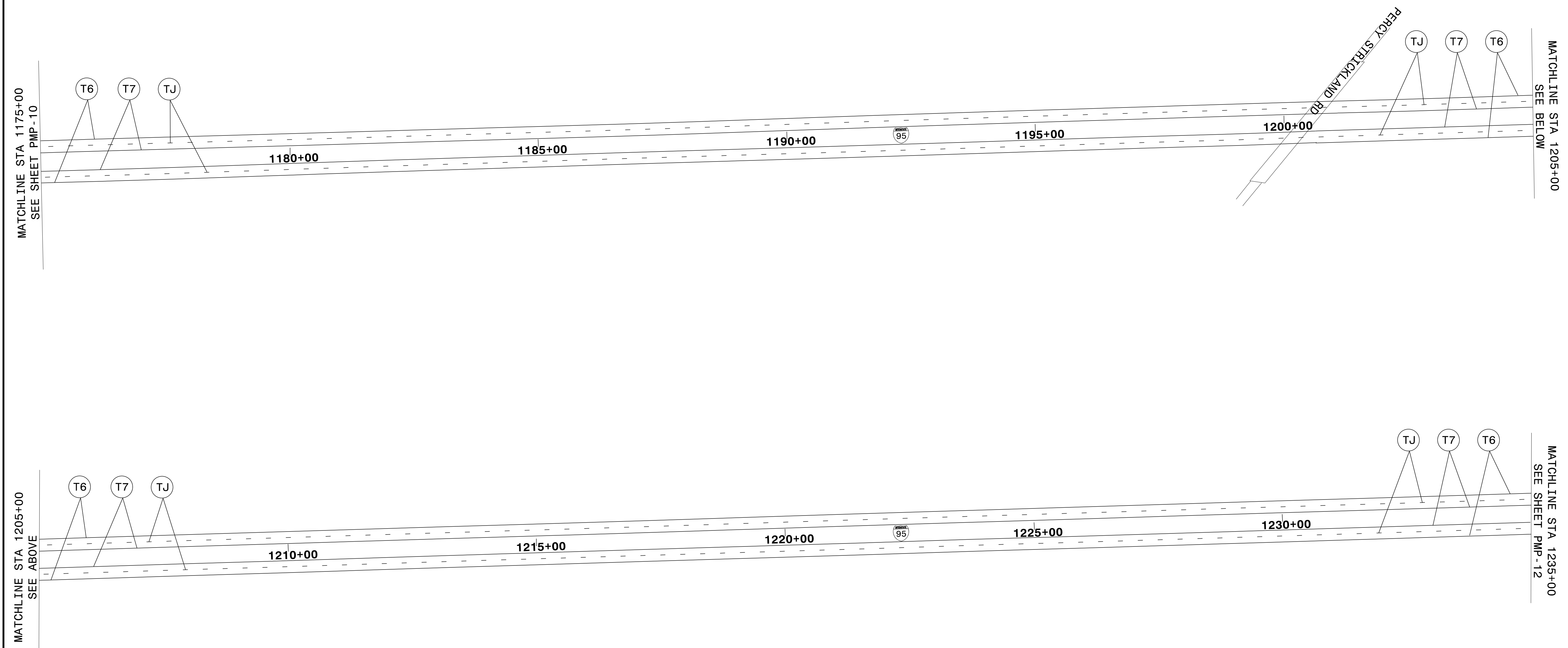

PAVEMENT MARKING DETAIL

TIP NO.	SHEET NO.
I-5788	PMP-12
APPROVED: <i>Ayman Alqudwah</i> <small>F32ACSCAF066472</small>	
DATE: 12/8/2015	
SEAL	

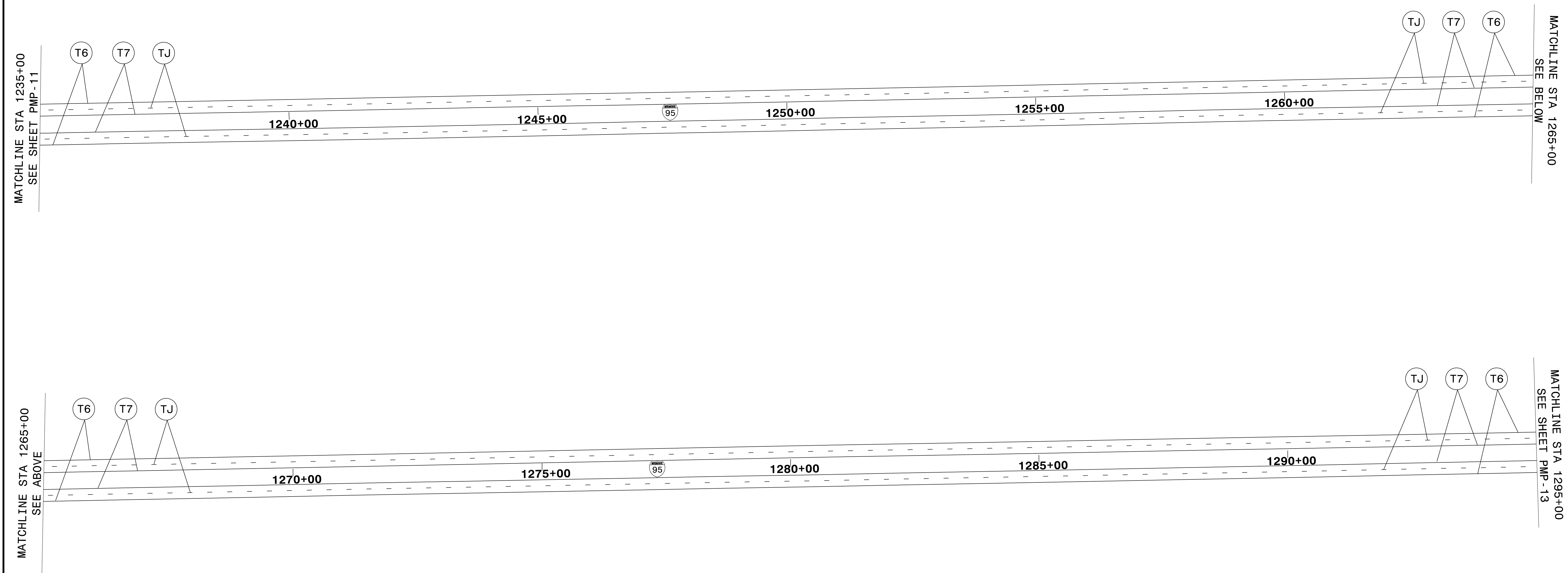
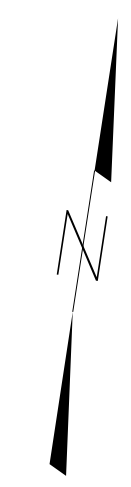
PAVEMENT MARKING DETAIL

TIP NO. I-5788	SHEET NO. PMP-13
APPROVED: <i>Ayman Alqudwa</i> <small>DESIGNED BY: F32ACSCAF066472</small>	
DATE: 12/8/2015	
SEAL	

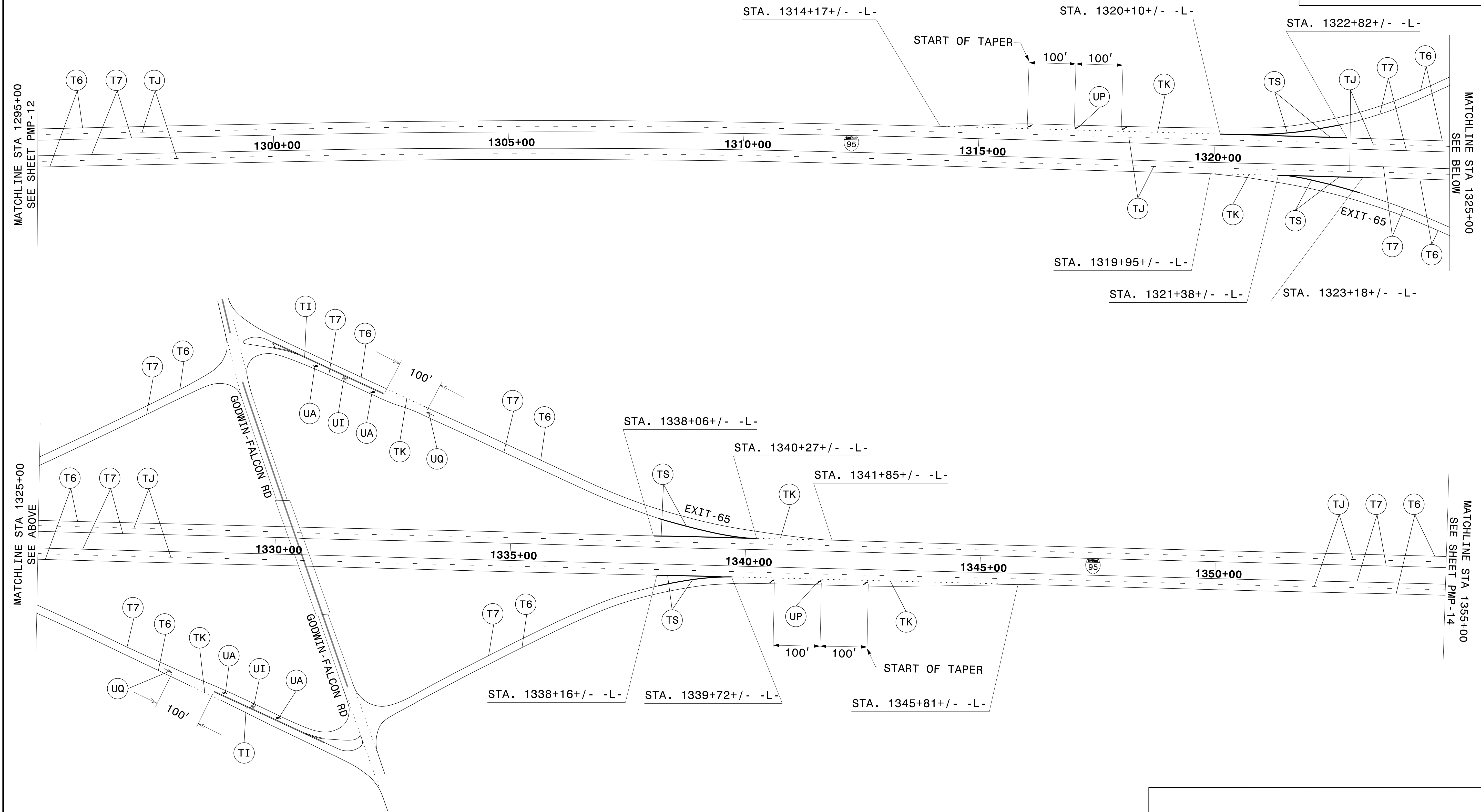
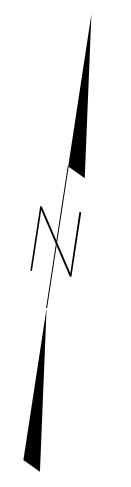

PAVEMENT MARKING DETAIL

TIP NO. I-5788	SHEET NO. PMP-14
APPROVED: <i>Ayman Alqudwa</i> <small>DESIGNED BY: F32ACSCAF066472</small>	
DATE: 12/8/2015	
SEAL	

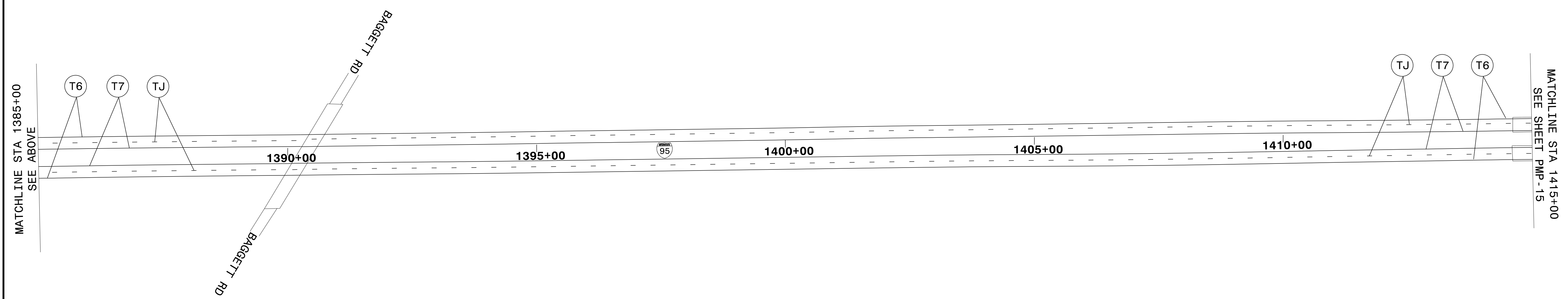
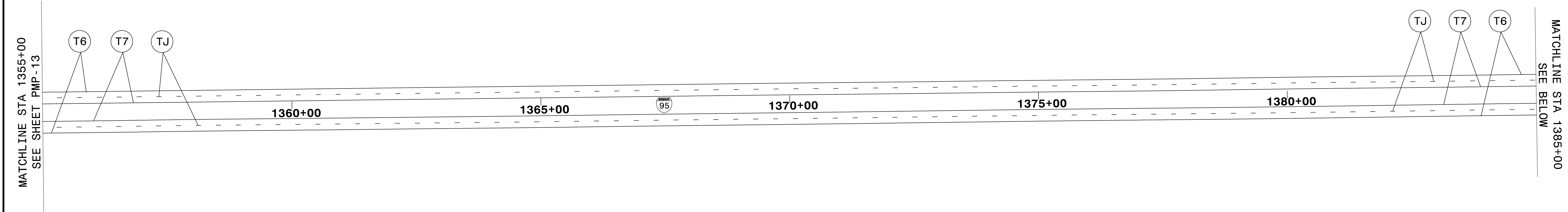

PAVEMENT MARKING DETAIL

TIP NO. I-5788	SHEET NO. PMP-15
APPROVED: <i>Ayman Alqudwa</i> <small>Designed by: F32ACSCAF066472</small>	
DATE: 12/8/2015	
SEAL	

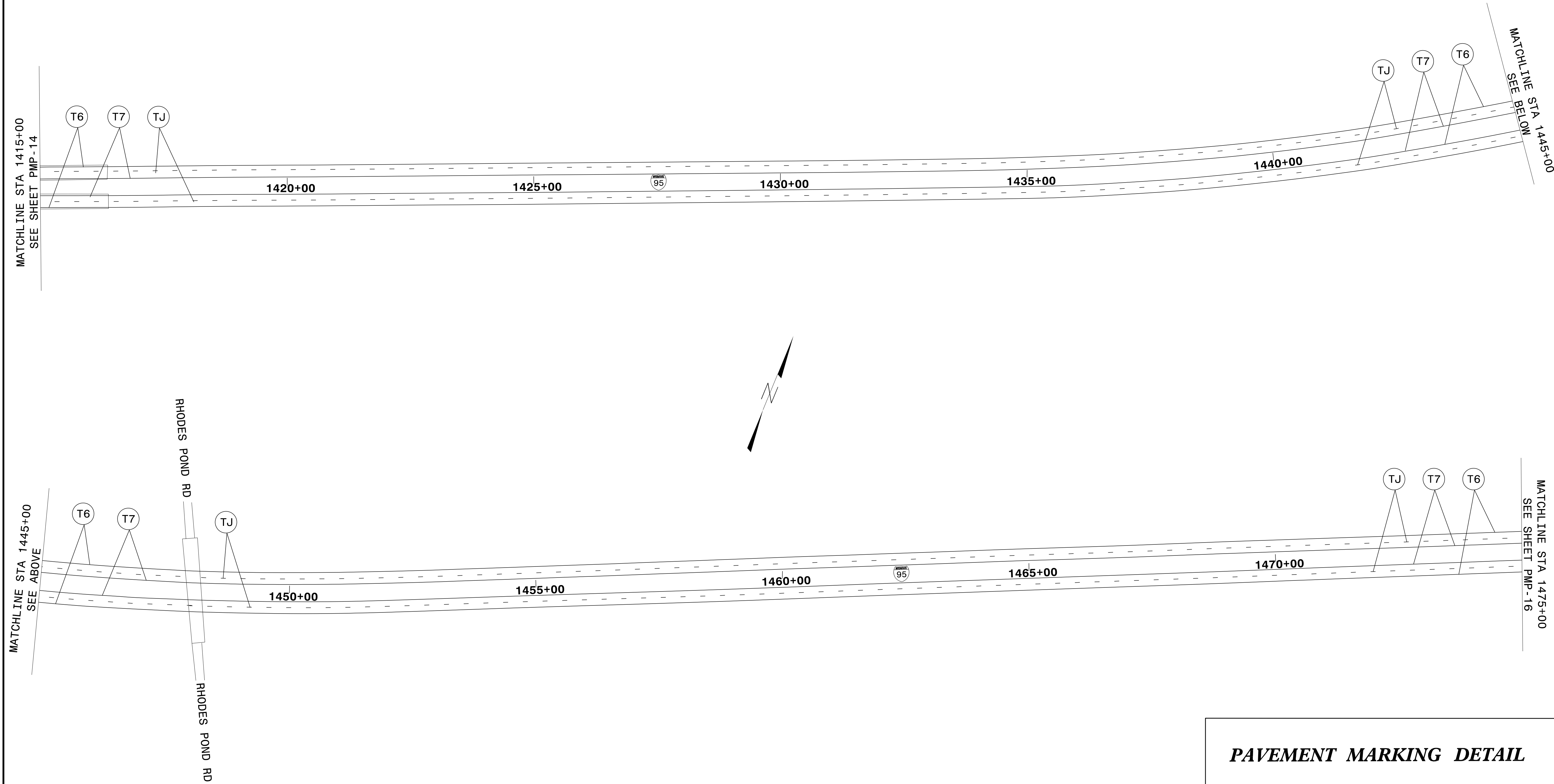

PAVEMENT MARKING DETAIL

TIP NO. I-5788	SHEET NO. PMP-16
APPROVED: <i>Ayman Alqudwah</i> <small>—Designed by— F32ACSCAF066472</small>	
DATE: 12/8/2015	
SEAL	

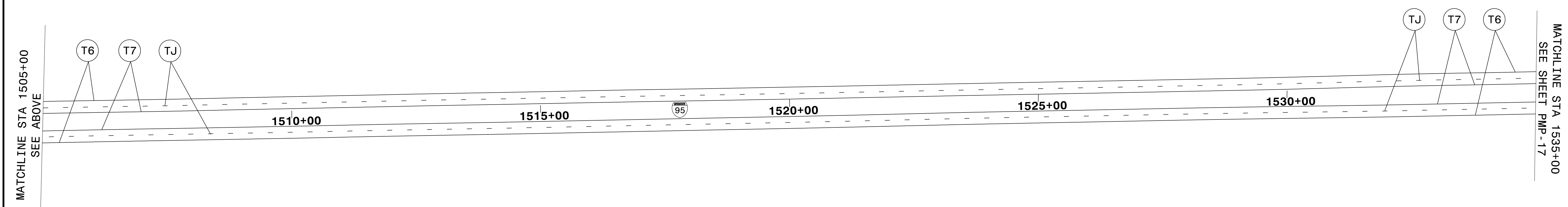
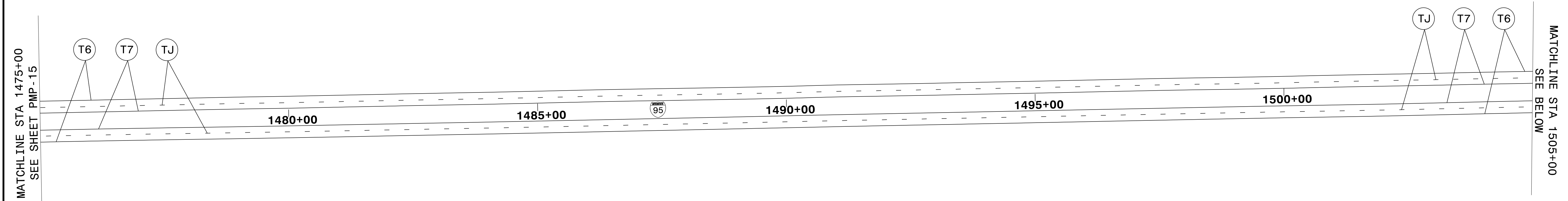
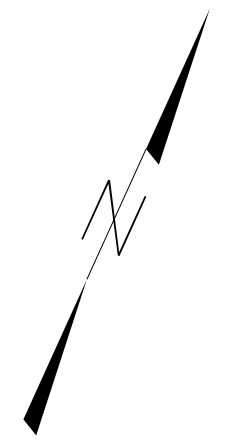

PAVEMENT MARKING DETAIL

TIP NO. I-5788	SHEET NO. PMP-17
APPROVED: <i>Ayman Alqudwah</i> <small>Designed by: F32ACSCAF066472</small>	
DATE: 12/8/2015	
SEAL 	

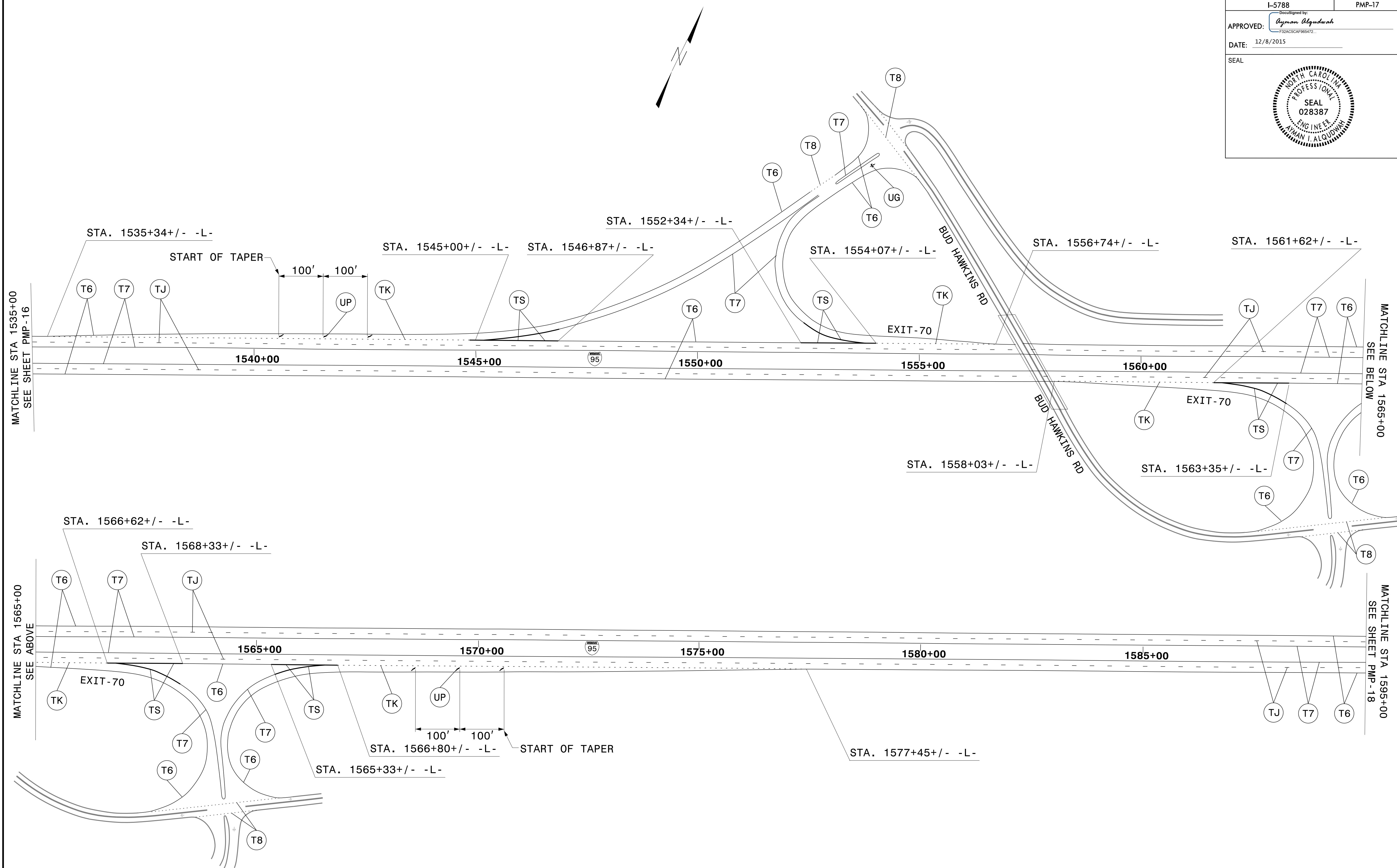

PAVEMENT MARKING DETAIL

TIP NO. I-5788	SHEET NO. PMP-18
APPROVED: <i>Ayman Alqudwah</i> F32ACSCAF065472	
DATE: 12/8/2015	
SEAL	

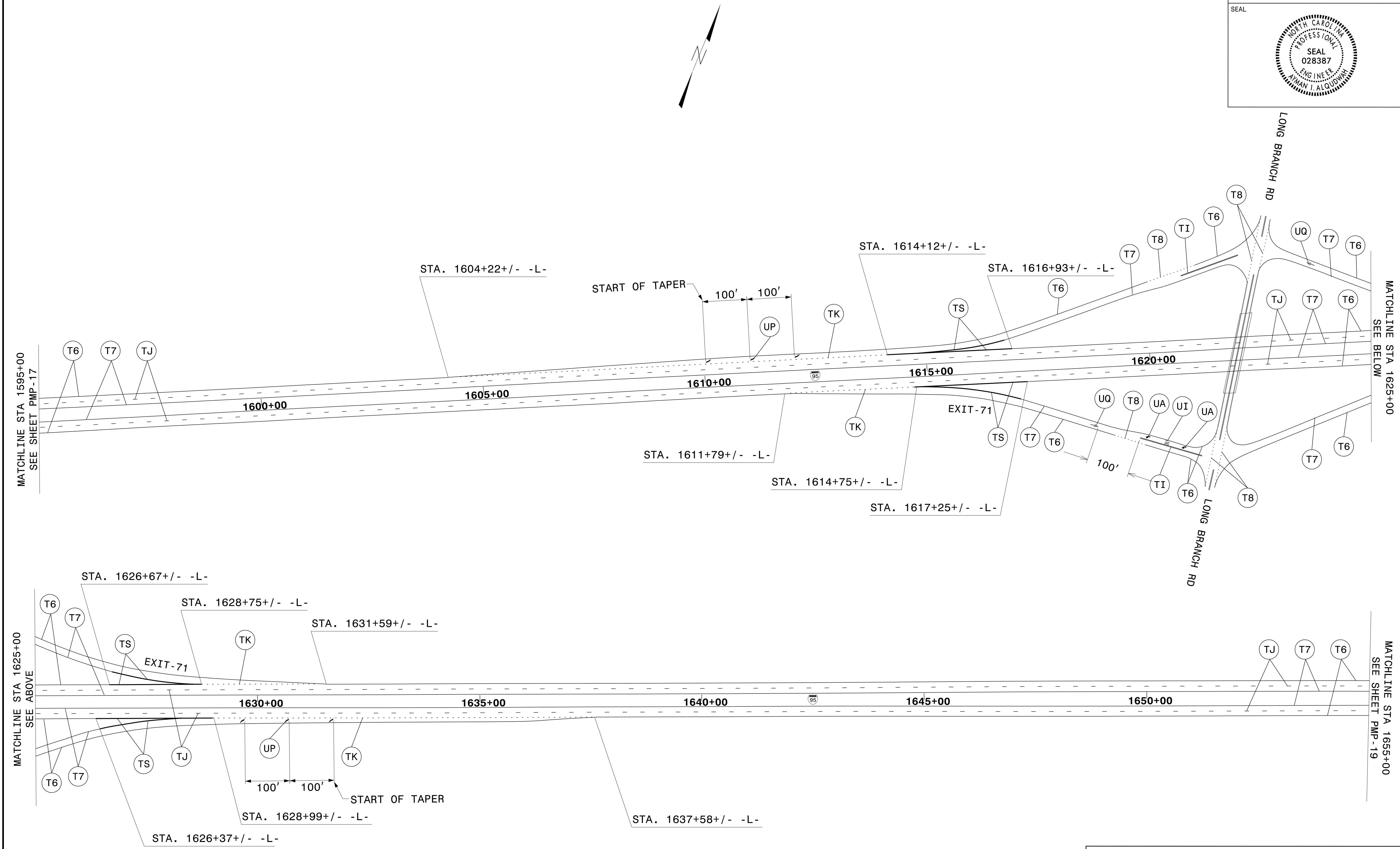

PAVEMENT MARKING DETAIL

TIP NO. I-5788	SHEET NO. PMP-19
APPROVED: <i>Ayman Alqudwah</i> F32ACSCAF066472	
DATE: 12/8/2015	
SEAL	

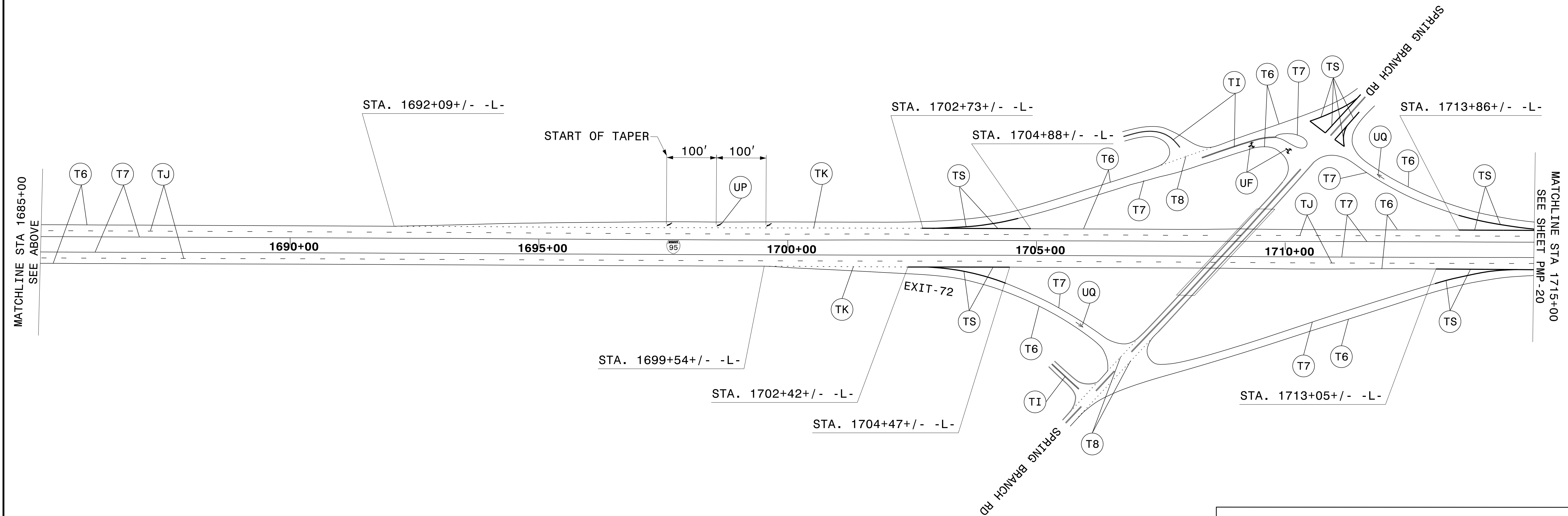
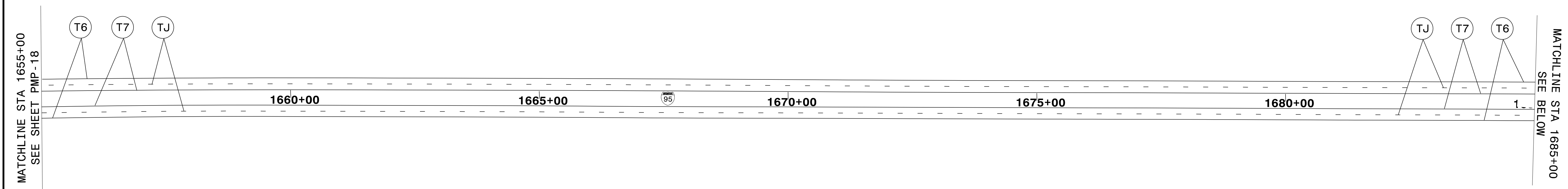
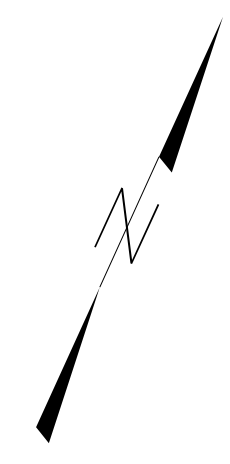

PAVEMENT MARKING DETAIL

MATCHLINE STA 1655+00
SEE SHEET PMP-18

MATCHLINE STA 1685+00
SEE BELOW

MATCHLINE STA 1685+00
SEE ABOVE

MATCHLINE STA 1715+00
SEE SHEET PMP-20

TIP NO. I-5788	SHEET NO. PMP-21
APPROVED: <i>Ayman Alqudwah</i> F32ACSCAF066472	
DATE: 12/8/2015	
SEAL	

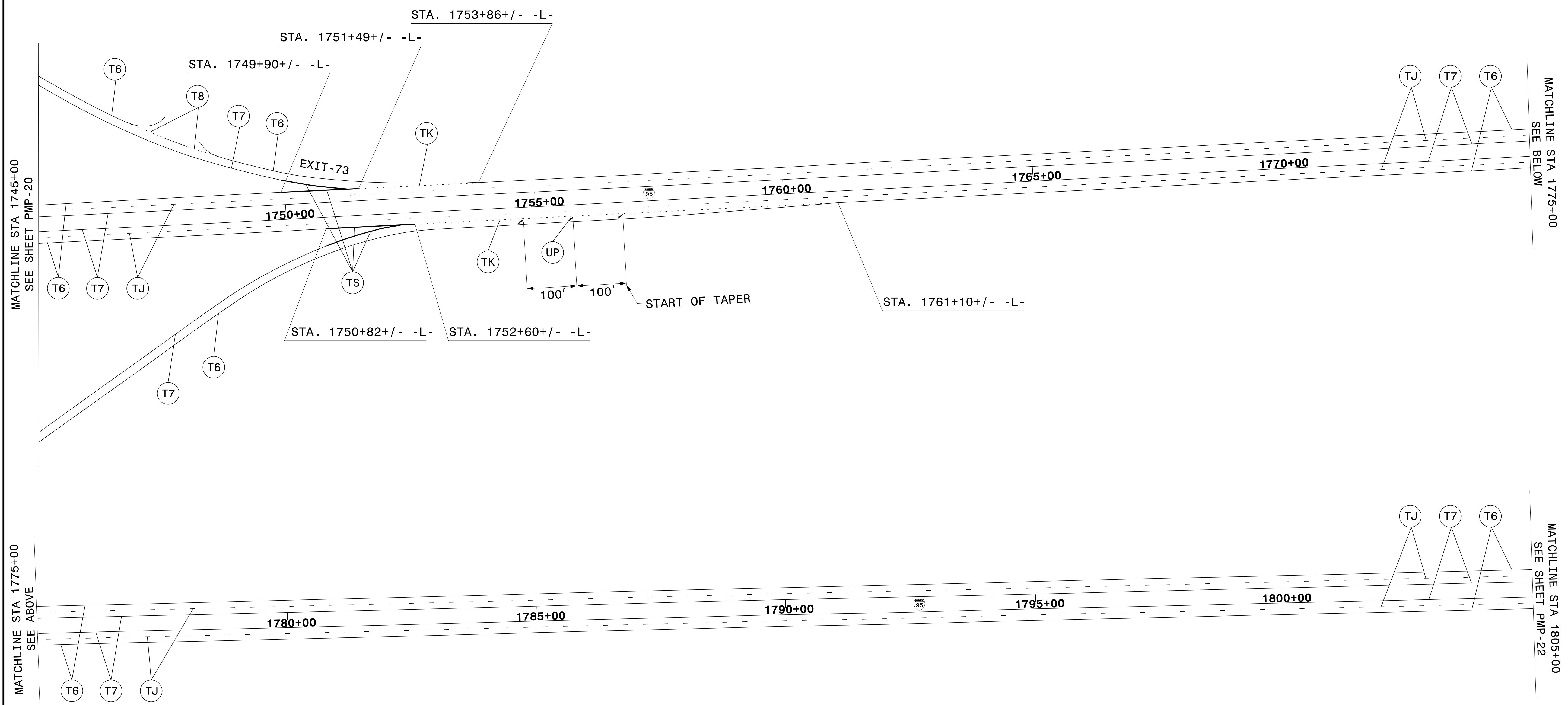
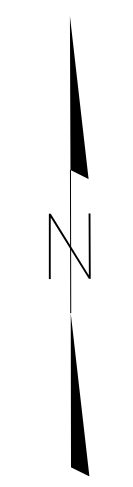

PAVEMENT MARKING DETAIL

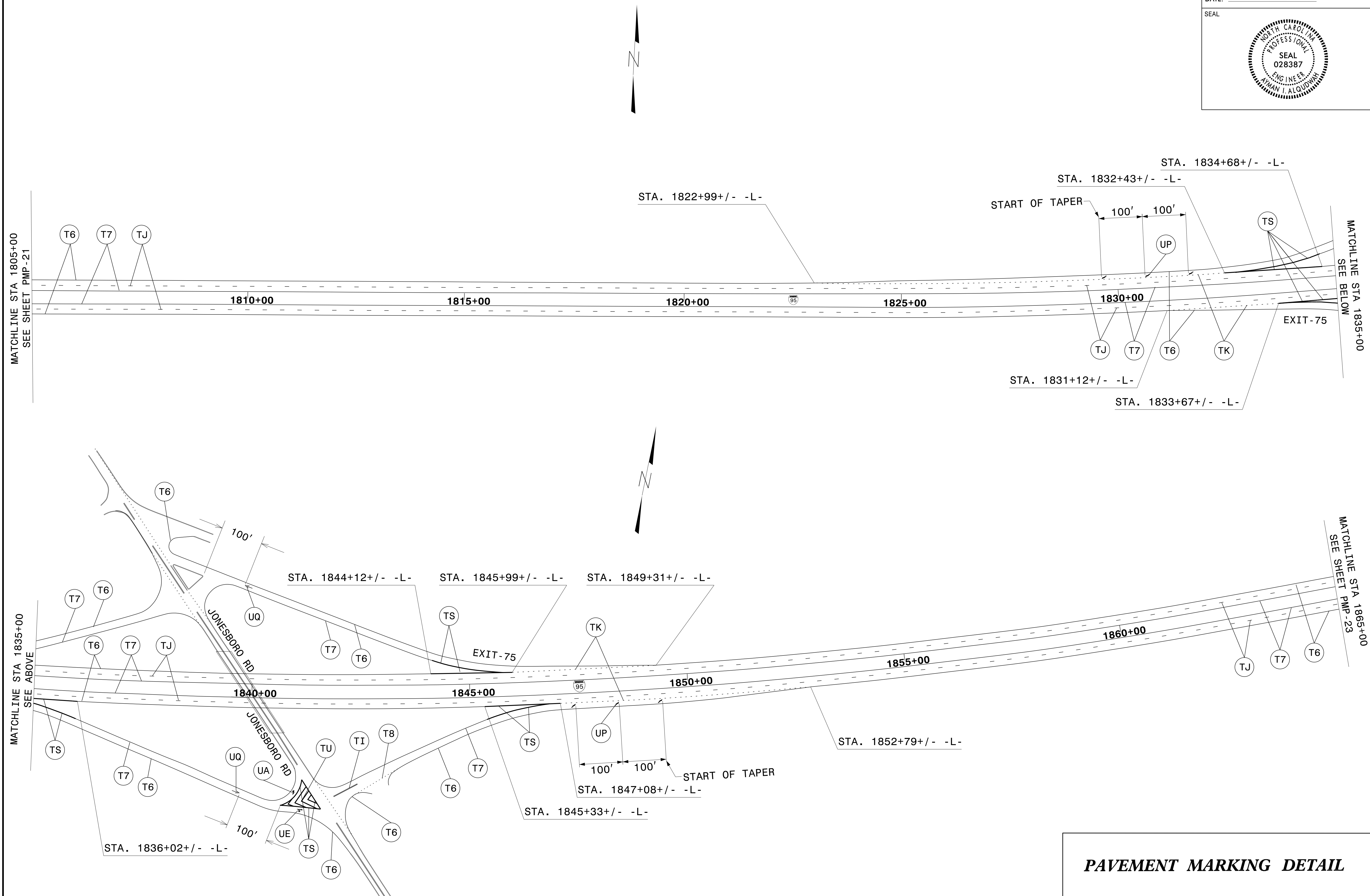

PAVEMENT MARKING DETAIL

TIP NO. I-5788	SHEET NO. PMP-23
APPROVED: <i>Ayman Alqudwah</i> <small>—Designed by—</small> <small>F32ACSCAF066472</small>	
DATE: 12/8/2015	
SEAL	

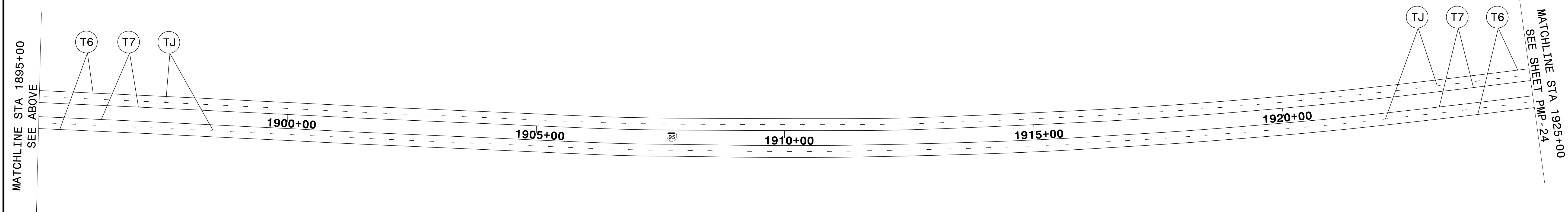
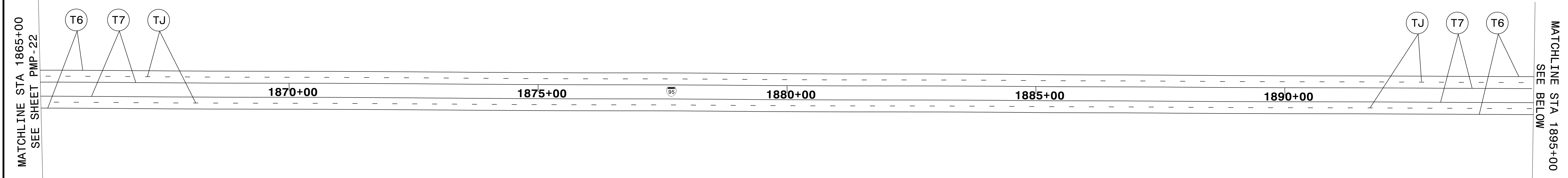
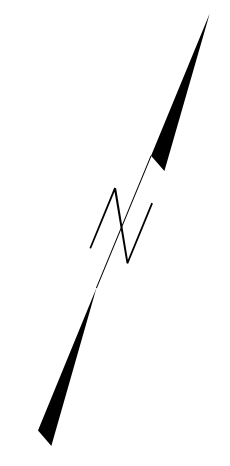

PAVEMENT MARKING DETAIL

TIP NO. I-5788	SHEET NO. PMP-25
APPROVED: <i>Ayman Alqudwah</i> <small>F32ACSCAF066472</small>	
DATE: 12/8/2015	
SEAL	

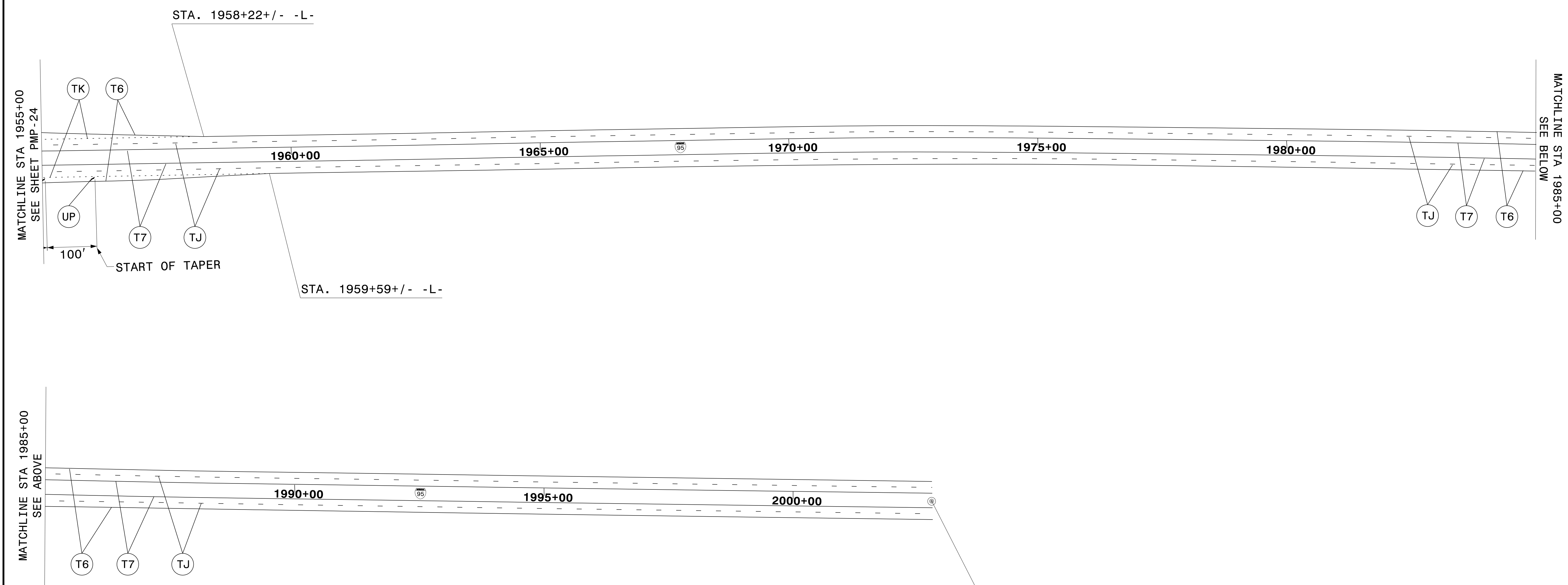
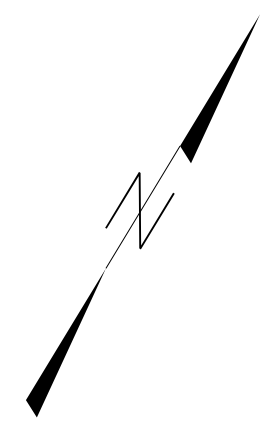

END MARKING PROJECT I-5788
 (MILE MARKER 78)
 STA. 2002+80 (+)
 TIE TO EXISTING MARKINGS

PAVEMENT MARKING DETAIL