

NOTES

STIRRUPS IN CAP MAY BE SHIFTED AS NECESSARY TO CLEAR DOWELS.

THE CONCRETE IN THE SHADED AREA OF THE WING SHALL BE POURED AFTER THE VERTICAL CONCRETE BARRIER RAIL IS CAST IF SLIP FORMING IS USED.

FOR PILE SPLICE DETAILS, SEE SHEET 3 OF 3.

FOR WING DETAILS, SEE SHEET 2 OF 3.

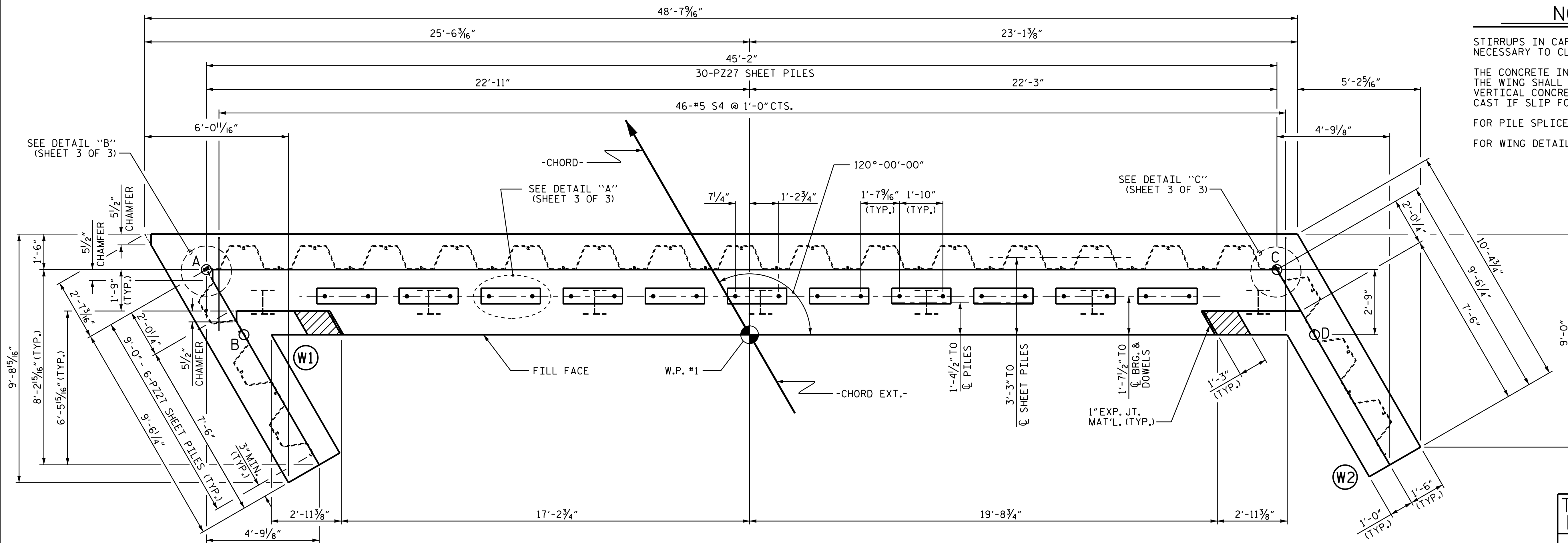

PLAN

CAP ELEVATIONS		
	TOP OF CAP	BOTTOM OF CAP
POINT A	2124.37	2121.87
POINT B	2124.31	2121.81
POINT C	2122.72	2120.22
POINT D	2122.67	2120.17

TOP OF PILE ELEVATIONS	
①	2122.79
②	2122.54
③	2122.28
④	2122.03
⑤	2121.78
⑥	2121.52
⑦	2121.27

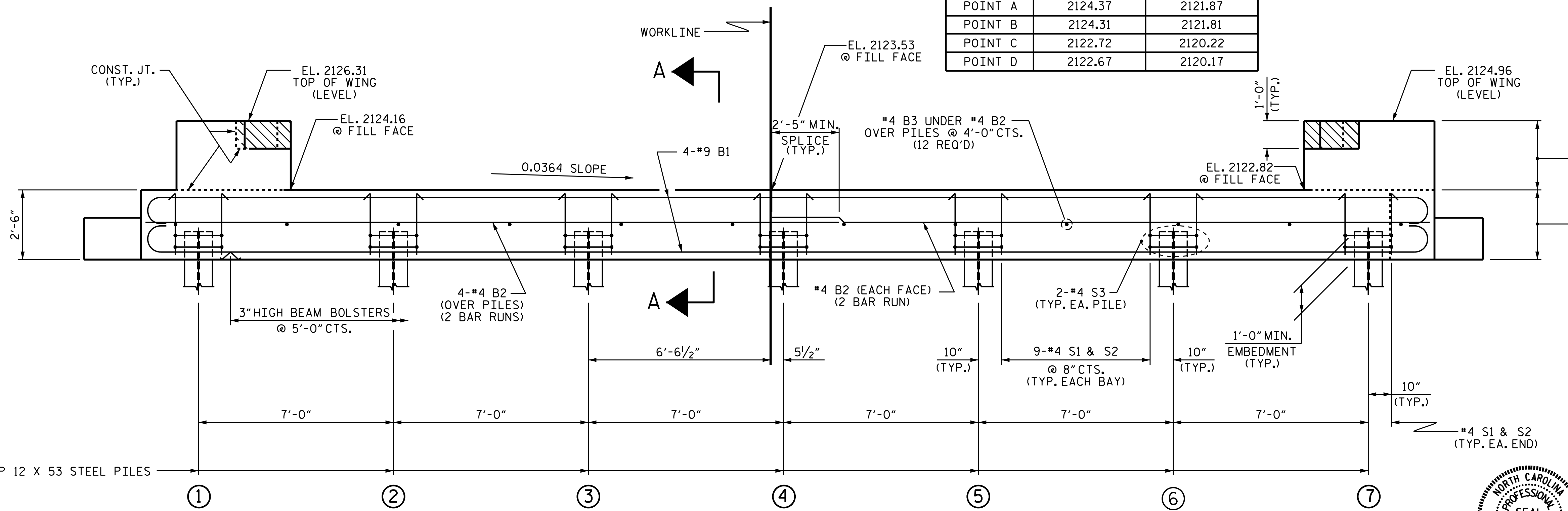

ELEVATION

WINGS AND SHEET PILES NOT SHOWN FOR CLARITY. FOR SECTION A-A, SEE SHEET 3 OF 3.

CONCRETE COLLARS FOR STEEL PILES NOT SHOWN IN PLAN AND ELEVATION VIEWS FOR CLARITY. SEE "CORROSION PROTECTION FOR STEEL PILES DETAIL", SHEET 3 OF 3.

PROJECT NO. B-5244
 BUNCOMBE COUNTY
 STATION: 14+02.00 -L-
 SHEET 1 OF 3

STATE OF NORTH CAROLINA
 DEPARTMENT OF TRANSPORTATION
 RALEIGH

SUBSTRUCTURE
 END BENT No. 1

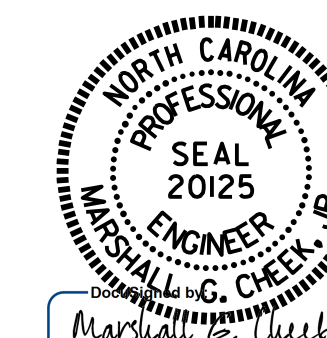

DRAWN BY: W.J. HARRIS DATE: 6/15
 CHECKED BY: B.N. GRADY DATE: 10/15
 DESIGN ENGINEER OF RECORD: W.J. HARRIS DATE: 12/15

DOCUMENT NOT CONSIDERED FINAL UNLESS ALL SIGNATURES COMPLETED

REVISIONS						SHEET NO.	
NO.	BY:	DATE:	NO.	BY:	DATE:	S-12	
1			3			TOTAL SHEETS 18	
2			4				